

ANIMAL BEHAVIOR AND COGNITION

Early life thermal stress: impacts on future temperature preference in weaned pigs (3 to 15 kg)

Lindsey A. Robbins,^{†,1} Angela R. Green-Miller,[‡] Jay S. Johnson,[§] and Brianna N. Gaskill[†]

[†]Department of Animal Sciences, Purdue University, West Lafayette, IN 47907, [‡]Department of Agricultural and Biological Engineering, University of Illinois at Urbana-Champaign, Urbana, IL 61801, [§]Livestock Behavior Research Unit, USDA-ARS, West Lafayette, IN 47907

¹Corresponding author: lindsey.robbyns.a@gmail.com

ORCID number: [0000-0001-5773-4142](https://orcid.org/0000-0001-5773-4142) (J. S. Johnson).

Abstract

Thermal stress can result in productivity losses, morbidity, and mortality if proper management practices are not employed. A basic understanding of the relationship between animals and the thermal environment is crucial to assess the environment's impact on livestock performance. Therefore, the study objective was to evaluate whether different early life thermal stressors (ELTS) altered the temperature preference of pigs later in life. Twelve sows and their litters were randomly exposed to 1 of 3 ELTS treatments from 7 to 9 d of age: early life heat stress (ELHS; cycling 32 to 38 °C; $n = 4$), early life cold stress (ELCS; 25.4±1.1 °C without heating lamp; $n = 4$), or early life thermoneutral (ELTN; 25.4±1.1 °C with a heating lamp; $n = 4$) conditions. From 10 to 20 d, (weaning) all piglets were exposed to ELTN conditions. At weaning, pigs were randomly assigned to groups of 4 of the same sex and ELTS treatment. Temperature preference, where pigs freely choose a temperature, was assessed in 21 groups ($n = 7$ groups per ELTS treatment) using 1 of 3 thermal gradient apparatuses (22 to 40 °C). Testing began at 26 ± 1.3 d of age to give pigs time to acclimate to solid food after weaning and 1 group per ELTS treatment were tested simultaneously in each apparatus. Pigs were given 24 h to acclimate followed by a 24-h testing period. Behavior (active and inactive), posture (upright, sternal, and lateral lying), and location were documented every 20 min using instantaneous scan samples. Preferred feeding temperature was determined by the latency to empty a feeder in each location. Data were analyzed using PROC MIXED in SAS 9.4. A cubic regression model was used to calculate the peak temperature preference of pigs based on the temperature pigs spent most of their time. The preference range was calculated using peak temperature preference ±SE for each ELTS treatment group. Early life thermal stress altered where pigs spent most of their time within the thermal gradient ($P = 0.03$) with ELTN pigs preferring cooler temperatures (peak preference of 23.8 °C) compared with their ELCS exposed counterparts (peak preference of 26.0 °C; $P < 0.01$). However, ELHS exposed pigs (peak preference of 25.6 °C) did not differ in their temperature preference compared with ELTN or ELCS exposed counterparts ($P > 0.05$). In summary, ELCS exposure altered pig temperature preference later in life indicating that ELTS can alter temperature preference in pigs.

Key words: early life thermal stress, pigs, temperature preference, thermal comfort zone

Abbreviations

BW	body weight
ELCS	early life cold stress
ELHS	early life heat stress
ELTN	early life thermoneutral
ELTS	early life thermal stress
HS	heat stress
RH	relative humidity
RR	respiration rate
T_A	ambient temperature
TCZ	thermal comfort
TNZ	thermoneutral zone
T_R	rectal temperature
T_S	surface temperature

Introduction

Prior exposure to temperature extremes may have a long-term impact on animal thermoregulation and thermopreferendum. Studies in early life heat stressed (ELHS) rodents have described improved thermotolerance to heat stress (HS) exposure later in life (Tetievsky and Horowitz, 2010). In addition, piglets exposed to early life cold stress (ELCS) may have a permanent reduction in body temperature (Heldmaier, 1974). Furthermore, a recent study determined that ELHS exposed pigs have reduced thermotolerance when exposed to an HS challenge immediately following weaning (Johnson et al., 2018). Taken together, these data indicate that early life temperature extremes can influence thermoregulation, which may have implications for future temperature preference.

Thermotolerance and body temperature are influenced by heat exchange between the animal and its environment (Johnston and Bennett, 2008), and a permanent shift in an animals' thermotolerance may result in an altered thermopreferendum. This is because the surface temperature (T_s) to ambient temperature (T_A) differential is the driving force for sensible heat exchange (Kingma et al., 2014). For instance, as body temperature increases, T_s increases to maintain a balance between heat production and heat dissipation (Kingma, et al., 2014). Since body temperature is increased more rapidly in ELHS pigs exposed to an HS challenge without a similar absolute T_s increase (Johnson et al., 2018), this suggests that a cooler T_A would be preferred to increase the thermal gradient and improve heat dissipation capacity. Alternatively, because ELCS pigs have a reduction in body temperature (Heldmaier, 1974), this may lead to greater vasoconstriction to conserve body heat (Campbell, 2008) resulting in a preference for warmer temperatures to reduce the thermal gradient. Therefore, the study's objective was to investigate whether early life thermal stress (ELTS) alters the temperature preference of pigs later in life. We hypothesized that pigs exposed to ELHS would prefer a cooler T_A and that ELCS pigs would prefer warmer temperatures relative to early life thermoneutral (ELTN) exposed pigs.

Materials and Methods

All procedures involving animal use were approved by the Institutional Animal Care and Use Committee at Purdue University (protocol #1701001525), and animal care and use standards were based upon the *Guide for the Care and Use of Agricultural Animals in Research and Teaching* (Federation of Animal Science Societies, 2010).

Early life thermal stress exposure

As described by Johnson et al. (2018), 12 first-parity sows with similar-sized litters ($n = 11.8$ piglets/litter; Duroc \times (Landrace \times Yorkshire)) were exposed to 1 of 3 ELTS treatments: ELTN (25.4 ± 1.1 °C with heating lamp; $n = 4$), ELHS (cycling 32 to 38 °C; $n = 4$), or ELCS (25.4 ± 1.1 °C without heating lamp; $n = 4$) from 7 to 9 d postfarrowing. All temperature treatments were based on the *Guide for the Care and Use of Agricultural Animals in Research and Teaching's* recommended thermal conditions for swine (Federation of Animal Science Societies, 2010). Thermal stress was verified through rectal temperature (T_R), T_s , average daily gain, thermal imaging, and respiration rate (RR) and these data are described by Johnson et al. (2018). After thermal treatment exposure (day 10 postfarrowing), piglets were housed under normal production conditions (25.4 ± 1.1 °C with $56.1 \pm 8.1\%$ relative humidity (RH) and supplemented with a heating lamp) until weaning (20.0 ± 1.3 d of age).

Experimental design: temperature preference

Mead's resource equation was used a priori to determine the number of groups needed for the 2×3 factorial design (2 sex \times 3 ELTS; Mead, 1990). Eighty-four pigs were randomly assigned (via random integer generator, random.org) to 1 of 21 testing groups that consisted of 4 same-sex pigs of the same early life thermal treatment (Table 1). Two pigs from each group were from the same litter.

At weaning, all pigs were re-located to nursery room 1 at the Purdue Animal Science Research Education Center (West Lafayette, IN). A nursery pen (0.95 m \times 1.43 m) held up to 8 pigs; therefore, if 2 testing groups were co-housed, they were treatment and sex matched. The nursery room received natural lighting via windows (15:9 light:dark), the average ambient temperature inside the nursery was 25 ± 5.8 °C with $58.1 \pm 10.5\%$ RH, and all pigs were given ad libitum access to food and water. Temperature preference testing began on June 7, 2017 (26 d \pm 1.3; 6.45 ± 1.26 kg BW) and ran until June 26, 2017 (39 d \pm 6.5; 9.71 ± 1.62 kg BW). Body weight (BW) was documented before each testing phase and added as a categorical variable by doing a mean split for each treatment (above or below the treatment average).

For temperature preference testing, pigs were transported in a cart ~91 m from the nursery to the environmental room. For each temperature preference testing session, 1 group of pigs from each ELTS treatment was randomly selected and simultaneously tested in 1 of 3 thermal apparatuses located within the environmental room. The pigs were allowed 24 h to acclimate to the new enclosure, thermal gradient, and environmental room. During acclimation and temperature

Table 1. Number of pigs and average weight exposed to early life thermal stress by sex

Parameter	Number of groups	Average weight, kg (LSM \pm SD)
ELTN		
Gilts	4	9.56 \pm 2.15
Barrows	3	9.18 \pm 1.59
ELCS		
Gilts	3	8.35 \pm 1.35
Barrows	4	8.82 \pm 1.55
ELHS		
Gilts	3	7.59 \pm 1.34
Barrows	4	8.89 \pm 2.60

preference testing, pigs were able to explore the entirety of the thermal apparatus. Each apparatus was cleaned in between acclimation, temperature preference testing, and between testing groups. Between acclimation and temperature preference testing, pigs were removed from the thermal apparatus and penned in an adjacent environmental room for ~2 h to clean and reestablish the thermal gradient. Waste was removed with a pressure washer, and the flooring and surrounding walls within the thermal apparatus were disinfected (LYSOL disinfectant all-purpose cleaner, Reckitt Benckiser LLC, NJ). After cleaning, the thermal gradient was considered stable when 3 readings, measured every 15 min, did not vary by more than 0.2 °C. Pigs were then returned to their assigned thermal apparatus for an additional testing period of 24 h. Precautions were taken to control for room position and side bias by balancing thermal treatments across the 3 thermal apparatuses as well as where, within the apparatus, pigs were initially placed. In addition, at least 1 group of barrows and 1 group of gilts were tested in each testing run. During experimental set-up and preference testing, researchers were not blinded to the pigs' ELTS treatment, but animal care staff were. During video coding, observers (L.R. and C.F.) were blinded to the ELTS treatment of the pigs and only the testing period was coded.

Thermal apparatus

The methods and materials were adapted in part from Robbins et al., (2018). Briefly, 3 thermal gradient apparatuses were built (3.05 m × 0.61 m × 0.61 m; L × W × H) to provide the required space per piglet and create the desired temperature gradient (Figure 1). To create the needed thermal gradient (20 to 40 °C), ceramic heating lamps (herein referred to as heating elements) were placed at strategic locations 0.46 m above the floor to create a constant

thermal gradient and were covered with wire mesh (Acorn international, Memphis, TN). The wire mesh was used to prevent the pigs from being accidentally burned should they be able to reach the heating elements. Plexiglas (MFG-Acrylic 1.52 m × 1.91 m × 0.61 m; Meyer Plastics, Inc., Lafayette, IN) was used to create a lid above each of the 2 halves of the thermal apparatuses. The cool end of all 3 thermal apparatuses had 2 computer fans (Coolermaster silent fan 120 S/2, Cool Master Technology Inc., Taiwan) to push cool ambient air into the apparatus and down the gradient to the hotter end where 6 exhaust holes were cut. Finally, 8 containers were used to supply the pigs with feed and water within the apparatus (Fortiflex MF-2 Mineral Feeder, 2 × 1.75 qt. capacity, 32.39 cm × 14.61 cm × 15.88 cm). Total water supplied between the 3 waterers was 11.36 L, and 2.27 kg total food was evenly allocated across the 5 feeding containers per day. Containers with feed were placed every 0.31 m along the right side of the thermal apparatus wall and containers of water were placed every 0.61 m along the left side of the thermal apparatus wall (Supplementary Figure 1).

The 3 thermal apparatuses were installed at Purdue University Animal Science Research and Education Center (West Lafayette, IN) in an environmentally controlled room. The environmental room RH and temperature were documented every 5 min (07:00 to 22:06 hours) for 3 d before pigs being placed inside, with the thermal apparatus air velocity and temperature measurements being taken every 15 min (Supplementary Table 1). Within the thermal apparatus, lines were drawn every 0.61 m to indicate thermal zones (5 thermal zones total; A to E) and ensure temperature was measured consistently (Supplementary Figure 1). The lines were used by observers to record the location of the pigs during video analyses.

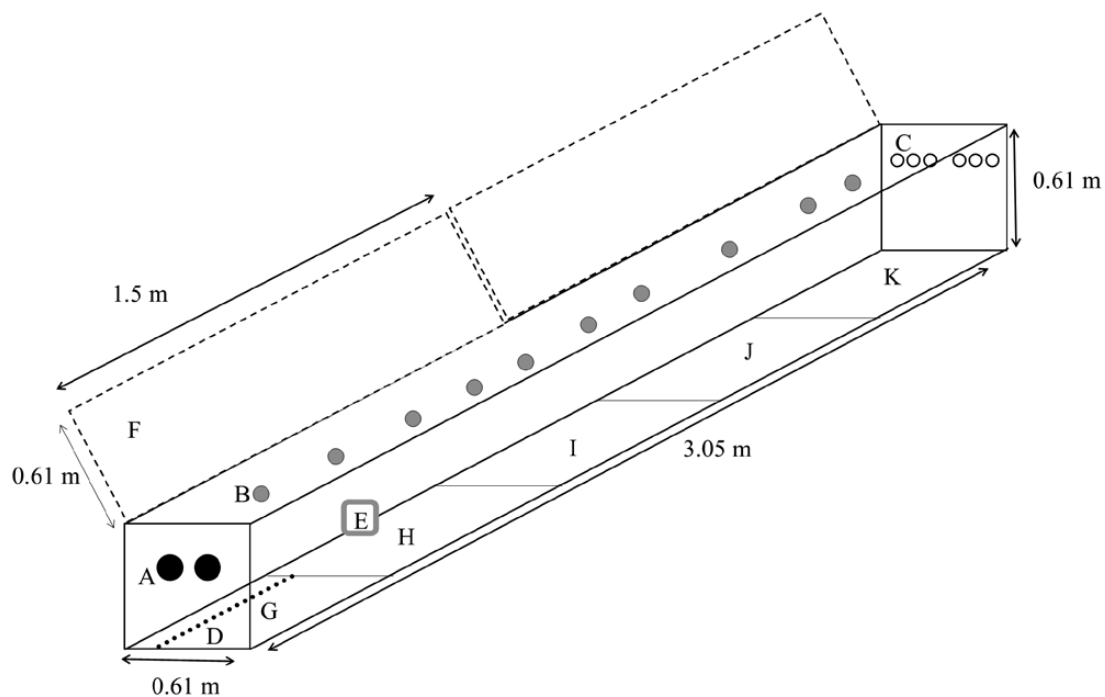

Figure 1. Right: photograph of a single thermal apparatus. (A) Two computer fans were used to push cool air into the apparatus; (B) heating elements placed at different intervals to warm the air as it moved down the apparatus; (C) 6 exhaust holes; (D) the dotted line indicates a 0.64-m spacing between solid lines used to create thermal zones where piglet location was documented; (E) example of height of container used for water and feed (see Figure 2 for more detail about container spacing); (F) 2 plexiglass lids covered the entire apparatus and opened upwards; (G) to (K) indicate the 5 thermal zones with average temperatures at: (G) 23.3 °C, (H) 26.2 °C, (I) 30.1 °C, (J) 34.2 °C, and (K) 38.2 °C.

Behavior and posture observations

The pigs were videotaped continuously over the 24 h testing period for behavior, location, and posture using infrared cameras (Sony Corporation, Tokyo, Japan) and video surveillance software (GeoVision, Taiwan). The scan interval used for recording data from video was determined by comparing different sampling intervals (5, 10, 15, 20, 25, and 30 min) based on the frequency of time spent at each location. Data from each subsample were compared pairwise and considered to accurately estimate the behavior or posture if the intervals were not significantly different from each other compared with the 5 min interval (Ledgerwood et al., 2010). Based on this data, a 20-min sampling interval was selected for this study. Thus, the location, behavior, and posture were recorded for each piglet using instantaneous scan samples every 20 min. The ethogram contained 3 simple behavior categories: active, inactive, and other (Table 2). If pigs were observed in more than 1 thermal zone (location), the proportion of a piglet in each zone was documented in 0.25 increments (head, front quarter, mid-section, and rump; Figure 2). Postures can indicate thermal comfort (Mount, 1960); therefore, posture was also documented at each scan sample (Table 3).

The frequency of behaviors was calculated for each group of pigs by counting the total number of times each behavior category was observed in each location per day and totaled per group. This calculation was repeated for posture. Any observations of pigs documented in the “other” category for behavior and posture were dropped from the dataset.

Food latency to empty

Video was used to determine the latency until each food container was emptied. If the food was not completely consumed, the maximum time pigs were in the apparatus (1,440 min) was assigned to that location-specific container. Food latency, rather than consumption, was used in the final analysis because once the pigs consumed all the food in that location, they would be forced to consume food in a location that may not reflect their true temperature preference.

Analyses

All analyses were performed using the PROC MIXED (GLM) procedure in SAS 9.4 (SAS Institute Inc., Cary, NC). The assumptions of the GLM (normality of error, homogeneity of variance, and linearity) were confirmed post hoc, and data

were transformed when necessary to meet these assumptions (Grafen and Hails, 2002). The threshold for significance $P < 0.05$ was used and Bonferroni corrected where applicable.

ELTS and BW at testing

The peak temperature preference was isolated by determining the temperature pigs were observed most often. The average end BW per group was analyzed with this single temperature preference to determine whether BW varied by group and BW predicted the temperature pigs spent most of their time in. Sex and ELTS were also included in this model as fixed effects.

Behavior and posture analysis by location

A cubic regression model was performed for both behavior and posture data and both were $\log_{10} + 0.001$ transformed to meet the assumption of a GLM. To avoid pseudoreplication and accommodate repeated measures, analyses were blocked by Group of pigs, nested within sex and ELTS. Group of pigs cannot be treated as a random effect, there is not a meaningful wider population of groups of 4 pigs representing the unique ELTS conditions they were reared in between 7 and 9 d of age to which the results could pertain (Newman et al., 1997) and was therefore treated as fixed effects. Main effects plus 3-way interactions of sex, ELTS treatment, behavior or posture, and location were originally tested with a cubic variable of location. However, due to nonorthogonal data, higher order interactions that were nonsignificant were dropped from the model. Weight category and any interactions were removed from the analysis because they were not significant, and Akaike information criterion was reduced when this variable was removed. Further, as data were not orthogonal, nonsignificant higher-order interactions were dropped from the final analysis.

The cubic curve from the final model above was generated in 0.2 °C increments starting with the coldest thermal zone temperature (23.2 °C) and increasing to the warmest temperature (38.2 °C). Peak temperature for ELTS, behavior, and posture was calculated by identifying the temperature with the greatest frequency. The temperature preference range was then calculated from the peak temperature \pm SE. Tukey tests for differences in LSM between ELTS, behavior, and posture were run in each thermal zone. Since Tukey tests were run 5 times (for each thermal zone), the α was Bonferroni corrected for the multiple tests ($\alpha = 0.05/5 = 0.01$).

Table 2. Ethogram used for behavioral observations

Category	Behavior	Description
Active	Active	Pig is walking about, can be seen actively engaged with the environment or with another pig. This includes fighting or head tossing with another pig or interacting with troughs located on the long ends of the thermal apparatuses such as biting or chewing.
	Eating	Pigs head is in the feeding trough, located under heating elements (5 total), can only see back of head and ears while within in the feeding trough. All food troughs are located under the heating lamps.
	Drinking	Pigs head is in the watering trough, located opposite wall to heating elements (3 total), can only see back of head and ears while within in the watering trough. Water troughs are located on the opposite side of the thermal apparatus from the heating elements.
Inactive	Inactive	Pig is motionless and assumed to be sleeping. The animal may be inactive if sitting, standing or lying still and alert. Animal is stationary, slow and small head movements may be seen but their body is motionless.
Other	Other	Pigs' behavior cannot be determined, camera angles or glare do not allow for accurate assessment
	Defecation	Pig is stationary or in a dog-sit position, can see fecal matter being excreted

Latency to empty feeders

Analyses were blocked by group of pigs, nested within sex, ELTS, and weight category. Main effects plus second-order interactions of sex, ELTS treatment, weight category, and temperature corresponding with the feeder location were tested. Data did not require transformation to meet the assumptions of a GLM (normality of error, homogeneity of variance, and linearity). The weight category was included with this model due to a higher R^2 value. Post hoc Tukey tests were used to evaluate significant terms in the model.

Results

ELTS and BW at testing

No differences in BW were detected between ELTS treatments (Table 4). Furthermore, BW did not affect peak temperature preference (Table 5).

Temperature preference and behavior

Early life thermal stress altered where pigs spent their time in the thermal gradient (GLM: $F_{2,176} = 3.47$; $P = 0.03$; Figure 4). ELTN pigs had a peak temperature preference of 23.8 °C (7.71%) with a preferred range between 23.2 and 25.2 °C (Table 6).

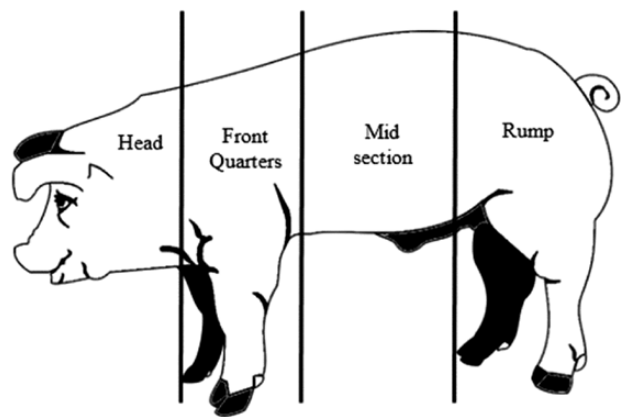

Figure 2. Diagram depicting sections of a pig used to assess percentage of body part located within a thermal section, each body section was equivalent to 25%. Head was considered from back of the ears to the snout, front quarters were considered back of the ears to behind the forelimbs, mid-section was from behind the forelimbs to front of the back limbs, and the rump was considered the front of the back limbs to base of the tail.

This preference was cooler by 2.2 °C compared with ELCS pigs ($_{u/3}: F_{1,176} = 7.93$; $P < 0.01$; Table 6). Early life cold stressed pigs spent the most amount of time at 26.0 °C (8.68%) but their temperature preference ranged between 24.8 and 27.6 °C (Table 6). Peak temperature preference did not differ when comparing ELHS and ELCS pigs ($_{u/3}: F_{1,176} = 2.79$; $P = 0.10$; Table 6). Early life heat stressed pigs had a peak temperature of 25.6 °C (6.59%) with a preferred range between 24.4 and 27.2 °C (Table 6). Finally, ELCS pigs spent more time at 34.2 °C compared with ELTN pigs ($_{u/5}: P < 0.02$; Figure 4).

Behavior altered where pigs were most frequently observed within the thermal gradient ($F_{1,176} = 25.89$; $P < 0.01$; Figure 3). Inactive behavior was observed most often at 24.6 °C (24.90%) and observed most frequently between 23.6 and 25.8 °C (Table 6). Active behavior was observed most often at a temperature of 25.8 °C (2.97%, range: 24.6 to 27.2 °C; Table 6). Further, Tukey tests ($_{u/5}$) showed that pigs spent more time inactive than active at 23.3 °C (19.63%), 26.2 °C (18.54%), and 30.1 °C (5.07%: $P < 0.01$; Figure 4) and peak temperature differed by 1.2 °C when comparing active and inactive behaviors ($_{u/2}: F_{1,176} = 34.87$; $P < 0.01$; Table 6).

Posture and temperature preference

The frequency of various postures differed across the thermal gradient (GLM: $F_{2,276} = 14.99$; $P < 0.01$; Figure 5). Upright posture was observed most at 25.6 °C (23.11%) and frequently observed between 24.4 and 27.0 °C (Table 6). Sternal laying posture was observed equally at 24.6 and 24.8 °C (23.98%) and observed most frequently between 23.6 and 26.0 °C (Table 6). Finally, in the lateral laying posture, pigs were observed most at 24.4 °C (44.59%; range: 23.2 to 25.6 °C; Table 6). The peak temperature for upright posture was warmer by an average of 0.9 °C compared with sternal ($_{u/3}: F_{1,276} = 13.31$; $P < 0.01$; Table 6) and by 1.2 °C compared with lateral lying postures ($_{u/3}: F_{1,276} = 28.73$; $P < 0.01$; Table 6). No difference was observed between peak temperature preferences when pigs were sternal or lateral laying ($_{u/3}: F_{1,276} = 2.93$; $P = 0.09$; Table 6). Further, Tukey tests ($_{u/5}$) showed that pigs were observed more in the lateral laying posture compared with both upright and sternal laying at 23.3 °C (24.35% and 20.35%, respectively) and 26.2 °C (14.59% and 15.86%, respectively: $P < 0.01$; Figure 5). Compared to sternal laying, pigs were observed upright most often at 30.1 °C (4.08%), 34.2 °C (2.79%), and 38.2 °C (3.67%: $P < 0.01$; Figure 5). However, compared to lateral lying, they were more often observed upright at 34.2 °C (2.17%) and 38.2 °C (3.56%: $P < 0.01$; Figure 5). Finally, pigs were observed most often in the lateral compared with the sternal lying posture at 30.1 °C (4.13%: $P < 0.01$; Figure 5).

Table 3. Ethogram used for posture observations.

Posture	Description
Upright	Pigs' body is erect and top line (back) is to the camera, includes pig standing on all 4 hoofs on ground and dog-sitting where pig has rump on floor
Sternal laying	Pig lies up-right with stomach and chest touching the ground, top line is facing the camera. This includes when a pig is sternal on her anterior body and lateral on her posterior body. Sternal includes the medial plane of the head and body being perpendicular to a 45-degree angle to the ceiling
Lateral laying	Pig lies on side with shoulder and rump touching the ground, top line is facing a wall. Medial plane of head and body are greater than 45° and ~90° to the ceiling
Other	Any other postures or those that cannot be determined, camera angles or glare do not allow for accurate assessment. When sow is in position transition and down on front knees but stays with hind end up for a while and may still be moving about

Table 4. Average end BW by ELTS and sex (LSM \pm SE) did not influence temperature preference

Parameter	BW, kg (LSM \pm SE)	F	P-value
ELTS		0.81	0.46
ELTN	9.37 \pm 0.64		
ELCS	8.58 \pm 0.64		
ELHS	8.24 \pm 0.64		
Sex		0.39	0.54
Gilts	8.96 \pm 0.51		
Barrows	8.50 \pm 0.54		

Table 5. Influence of parameters on temperature preference (LSM \pm SE)

Parameter	F	P-value
ELTS	1.25	0.32
Sex	1.22	0.29
End BW	2.59	0.14

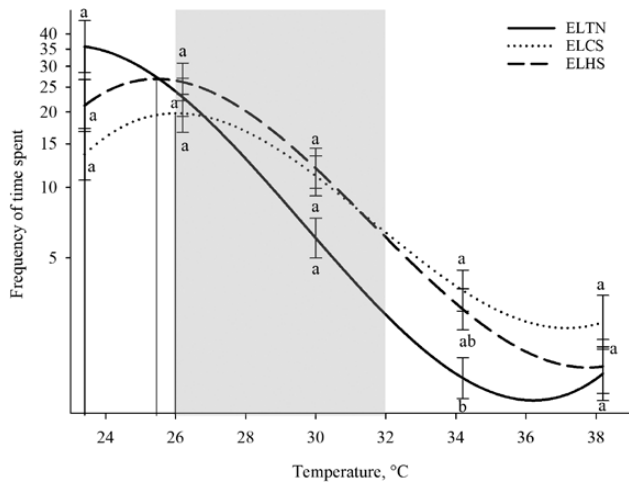
**Figure 3.** Total frequencies of time spent in different temperatures within the thermal gradient based on ELTS conditions. The effects of ELTN, ELCS, and ELHS on temperature preference. Temperature within the thermal apparatus is plotted on the x-axis and total frequencies are plotted on the y-axis as a log₁₀ scale. Cubic peaks are indicated by vertical lines corresponding to ELTS. Standard error bars are located at the temperatures of the 5 thermal zones (23.3, 26.2, 30.1, 34.2, and 38.2 °C) and different letters denote significant Tukey pairwise comparisons ($P < 0.01$). The gray box indicates the recommended temperatures (26 to 32 °C) for piglets between 3 and 15 kg (Federation of Animal Science Societies, 2010).

Food latency

The latency to empty the various feeders depended on its thermal location (GLM: $F_{4,56} = 4.11$; $P < 0.01$; Figure 6). Pigs consumed food the fastest from the feeder at 26.2 °C compared with 34.2 °C (175.67 min) and 38.2 °C (190.62 min; $P < 0.05$; Figure 6). An interaction of sex and weight category (GLM: $F_{1,80} = 5.00$; $P = 0.03$; Table 7) and ELTS and sex (GLM: $F_{2,80} = 3.57$; $P = 0.03$; Table 7) altered the latency times; however, post hoc Tukey tests did not identify any significant comparisons ($P > 0.05$).

Discussion

This study experimentally looked at the effects of ELTS on the future temperature preference of pigs. Body temperature

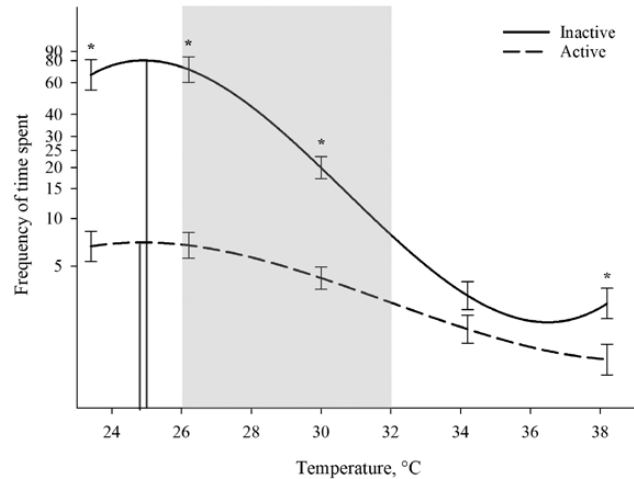
**Figure 4.** Total frequencies of time spent in different temperatures within the thermal gradient based on behavior. Data are plotted by behavior: active and inactive. Temperature within the thermal apparatus is plotted on the x-axis and total frequencies are plotted on the y-axis as a log₁₀ scale. Cubic peaks are indicated by solid vertical lines. Standard error bars are located at the temperatures of the 5 thermal zones (23.3, 26.2, 30.1, 34.2, and 38.2 °C). An asterisk indicates significant Tukey tests ($P < 0.01$). The gray box indicates the recommended temperatures (26 to 32 °C) for piglets between 3 and 15 kg (Federation of Animal Science Societies, 2010).**Table 6.** Peak temperature preference (°C) by ELTS, behavior, and posture (LSM \pm SE)

Parameter*	Peak temperature preference, °C	Average time spent at peak temperature, %	Temperature preference range, °C
ELTS			
ELTN*	23.8	7.71	23.2 to 25.2
ELCS*	26.0	8.68	24.8 to 27.6
ELHS*	25.6	6.59	24.4 to 27.2
Behavior			
Inactive	24.6	24.9	23.6 to 25.8
Active	25.8	2.97	24.6 to 27.2
Posture			
Upright*	25.6	23.11	24.4 to 27.0
Sternal*	24.6 and 24.8	23.98	23.6 to 26.0
Lateral*	24.4	44.59	23.2 to 25.6

Different symbols denote a significant difference in peak temperature preference between parameters Tukey tests ($P < 0.01$).

is influenced by heat exchange between the animal and its environment (Johnston and Bennett, 2008), and previous research has demonstrated a permanent shift in an animals' thermotolerance when exposed to HS during the early stages of development (as reviewed by Horowitz, 2007). This shift in thermotolerance may result in an altered temperature preference due to the T_s to T_A differential as the driving force for sensible heat exchange (Kingma et al., 2014). Thus, this study hypothesized that exposure to ELTS would result in an altered temperature preference in pigs later in life.

Results in the present study demonstrated that ELTS influenced temperature preference between ELCS and ELTN pigs. Early life cold stressed pigs spent most of their time between 24.8 and 27.6 °C, and as predicted, ELCS pigs had a peak temperature preference that was 2.2 °C warmer when compared with ELTN pigs. Early life cold stressed pigs may have greater

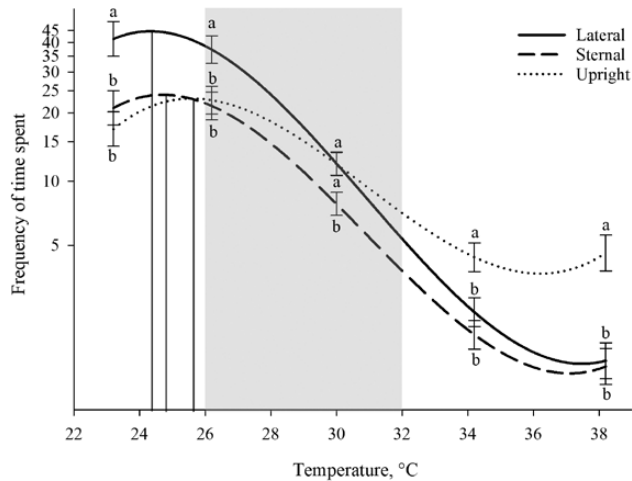

Figure 5. Total frequencies time spent in different temperatures within the thermal gradient based on posture. Data are plotted by postures: lateral and sternal lying, and upright. Temperature within the thermal apparatus is plotted on the x-axis and total frequencies are plotted on the y-axis as a log₁₀ scale. Cubic peaks are indicated by solid vertical lines. Standard error bars are located at the temperatures of the 5 thermal zones (23.3, 26.2, 30.1, 34.2, and 38.2 °C). Different letters denote significant Tukey pairwise comparisons ($P < 0.01$). The gray box indicates the recommended temperatures (26 to 32 °C) for piglets between 3 and 15 kg (Federation of Animal Science Societies, 2010).

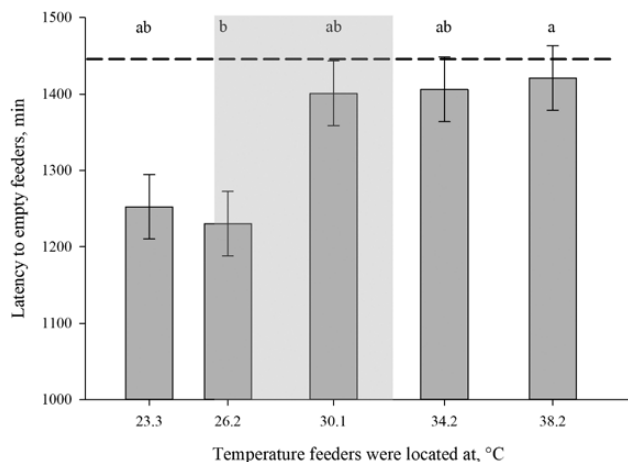

Figure 6. Latency to empty feeders located within the 5 thermal zones: 23.3, 26.2, 30.1, 34.2, and 38.2 °C. Data presented as LSM \pm SE ($n = 7$ per ELTS treatment). Different letters denote significant Tukey pairwise comparisons ($P < 0.05$). Dotted line indicates the maximum amount of time pigs had to consume food (1440 min). The gray box indicates the recommended temperatures (26 to 32 °C) for piglets between 3 and 15 kg (Federation of Animal Science Societies, 2010).

vasoconstriction resulting in improved heat conservation (Heldmaier, 1974), which could explain the shift in temperature preference when compared with ELTN pigs. Unfortunately, due to the nature of this study, body temperature data (e.g., skin surface and body temperature) could not be documented while the animals were inside the thermal apparatus and it cannot be confirmed if vasoconstriction caused the shift in temperature preference for ELCS pigs. Although preferences differed between ELCS and ELTN pigs, the actual treatments only differed by the presence/absence of heat from a heating lamp. Both the ELCS and ELTN pigs were exposed to the same barn level T_A , but the heating lamp for ELCS pigs was turned off. These results support

Table 7. Latency to empty feeders (min) based on interaction effects (LSM \pm SE)

Parameter	Interaction parameter	Time to empty feeders, min
Weight*	Sex	
	Above	Barrow 1,378 \pm 31 Gilt 1,315 \pm 40
Below	Barrow	1,279 \pm 50
	Gilt	1,397 \pm 40
ELTS		
ELTN	Barrow	1,272 \pm 53
	Gilt	1,354 \pm 43
ELCS	Barrow	1,291 \pm 50
	Gilt	1,418 \pm 53
ELHS	Barrow	1,422 \pm 50
	Gilt	1,297 \pm 53

*Weight category was calculated by the average weight of piglets' post-testing and separated by ELTS.

that the radiant heat given off by the lamp is influential on pigs' thermoregulatory development.

Temperature preferences were similar between ELHS pigs and the other treatments, but this may be related to the specific ELHS protocol. Acquiring thermotolerance is a transient process and depends primarily on the severity and duration of the initial HS. In general, the greater the initial heat dose, the greater the duration of thermotolerance. For example, following a sublethal heat exposure, thermotolerance (based on the presence of HSP70) can be observed within several hours and lasts 3 to 5 d (as reviewed by Kregel, 2002). Perhaps, if we had tested temperature preference within 5 d of ELTS, rather than beginning at weaning (day 20), we may have observed a more drastic difference in temperature preference. Despite the lack of differences between ELHS and the other treatments, this study provides further knowledge about factors that influence the TCZ of pigs.

Understanding the TCZ of an animal is critical to creating temperature recommendations and providing an optimal environment both for production and welfare. Interestingly, these results demonstrated a shift in the preferred temperature range of group-housed pigs under these conditions. The ELTN pigs appeared to prefer cooler temperatures than what is stated in the *Guide for the Care and Use of Agricultural Animals in Research and Teaching* (Federation of Animal Science Societies, 2010), with ELTN pigs spending more time between 23 and 25 °C than expected. While our data overlap with temperatures thought to be preferred by 3 to 15 kg piglets (25 to 32 °C; Federation of Animal Science Societies, 2010), pigs in this study spent $\leq 15\%$ of their time in temperatures above 29 °C. The shift in temperature preference may be because the *Guide for the Care and Use of Agricultural Animals in Research and Teaching* (Federation of Animal Science Societies, 2010) recommendations are based on swine genetics from nearly 40 yr ago (NRC, 1981; DeShazer and Overhults, 1982; Curtis, 1985; Hahn, 1985). Since the publication of the original research, total heat and moisture production in current genetic lines has increased by an average of 16%, ranging from 10% to 32% across production stages (Brown-Brandl et al., 2014). This increase in heat production may have contributed to the decrease in preferred ambient temperatures observed in this study.

An additional explanation of the temperature discrepancy between this study and the *Guide for the Care and Use of*

Agricultural Animals in Research and Teaching (Federation of Animal Science Societies, 2010) could be due to the social environment. The recommendations are based on data from individually tested piglets, rather than a group. This is a very important distinction since social behavior and physical contact can influence temperature preference. In a preference test, pigs preferred to lie near an anesthetized littermate rather than lie within comfortable temperature alone (Hrupka et al., 2000). Group-housed pigs are often observed huddling together or touching each other when resting. The heat conserved from huddling would make normally cool temperatures for an individual much more comfortable when in a group (Mount, 1963; Hrupka et al., 2000).

Animals have an innate motivation to seek out a preferred T_A , referred to as thermopreferendum (Gordon et al., 1993). Thermopreferendum is where animals seek to decrease the temperature difference between the environment and the animal and allowing an animal to minimize energetic costs (Terrien et al., 2011). In this study, pigs spent very little time active (~15%) and the peak temperature preference was not different during inactive behaviors. The minimal amount of time active could have limited our ability to observe temperature preferences based on activity. It is also possible that with so little activity, pigs did not build up enough metabolic heat to alter their preference.

Animals generally seek out cooler temperatures when active; however, the opposite is observed during inactivity. Mammals typically experience a decline in core body temperature during sleep that correlates with their circadian rhythm (as reviewed by Harding et al., 2019). Mice have demonstrated a clear thermal preference during their sleep phase, choosing warmer environments approaching thermoneutrality (27 to 30 °C) minimizing energy expenditure (Gordon et al., 1993; Gaskill et al., 2012). Previous literature has demonstrated that pigs will select cooler temperatures when sleeping (Bench and Gonyou, 2007), compared with when active. In this study, the ethogram did not distinguish between sleep and animals that may have been still but alert. Had we done so, perhaps we would have observed a difference in thermal preference based on behavior.

Posture is another mode of behavioral thermoregulation that alters the rate of heat loss by changing the amount of surface area exposed to the environment. There is a linear relationship between lateral lying and environmental temperature in pigs (Pedersen et al., 2003; Huynhab et al., 2005; Aarnink et al., 2006). When housed within their TCZ, pigs prefer to lay near each other with minimal contact and predominately lie in a lateral posture (Huynhab et al., 2005). A warmer temperature however reduces conspecific contact and increases the amount of lateral lying (Huynhab et al., 2005; Aarnink et al., 2006). The lateral lying posture increases skin contact with the floor allowing for greater heat exchange and lessens the heat load if an animal is experiencing HS. In this study, pigs in the 3 coolest thermal zones (23.3, 26.2, and 30.1 °C) spent more time in a lateral posture (~45%), compared with sternal lying (~24%). Although they spent different amounts of time in these postures, there was no significant difference between the peak temperatures in sternal (24.6 and 24.8 °C) or lateral lying (24.4 °C). The lack of differences between sternal and lateral lying could be due to space limitations within the thermal apparatus or the piglet's desire to lay near a littermate. Overall, pigs spent most of their time in the lateral posture at a temperature below the *Guide for the Care and Use of Agricultural Animals in*

Research and Teaching (Federation of Animal Science Societies, 2010) recommendations. The fact that the pigs chose cooler temperatures than expected and were lying in a posture that indicates comfort, supports that the preferred temperatures are within their TCZ.

Animals maintained at high or low T_A for long periods modify their physiological responses to adapt to that T_A . To fuel the increased energetic needs and maintain a positive energy balance during cold exposure, animals need to adapt their food intake. An increase in caloric intake has been described in numerous species (including pigs), to counteract cold-induced costs of thermoregulation (Dauncey and Ingram, 1986). Although food consumption was measured in this study, pigs could move freely between temperatures and thus food consumption was not directly altered by temperature. However, the amount of time it took pigs to empty the food bins reveals the temperatures in which they preferred to eat. Regardless of their ELTS, pigs consumed food at a faster rate in the 2 coolest temperature zones (23.3 and 26.2 °C). These data indicate that those studying nutrition and production, may want to house their pigs between these temperatures to keep pigs within their TCZ and still promote feed intake. This unsurprisingly correlated with the thermal zones they spent the most amount of time in. Unfortunately, this measure also comes with limitations. When the preferred feeders were emptied, the pigs had to move into other thermal zones to consume feed, thus adding variability to both our behavioral and location data. However, this may not have significantly influenced our data since pigs spent only ~15% of their time active, which included feeding behavior.

This study was able to successfully identify the effects of ELTS on thermal choice in group-housed pigs, regardless of the limitations. The inability to achieve the target temperature range (20 to 40 °C) was unfortunate since we were unable to locate the lower critical temperature of ELTN pigs. Ideally, the data would have taken on more of a traditional bell curve shape to help us identify temperatures that indicate upper and lower critical temperature limits. However, for ELTN pigs, the lower critical temperature was not observed due to the limitations with establishing cooler temperatures within our gradient. Unfortunately, the inability to achieve these desired temperatures was due to the limitation of our facilities during the summer months. The environmental room, where the thermal apparatuses were located, was unable to reduce the T_A enough to achieve the required lower thermal gradient. Additional limitations in our design did not provide the ideal amount of floor space for the larger pigs. A larger floor space within each thermal zone would have allowed for better spacing of both feeders and waterers, and for all animals to fit within each zone easily. Unfortunately, due to size constraints, the design used was best situated for the environmental room it was placed in and allowed for all ELTS to be run simultaneously.

Conclusion

We hypothesized that temperature preference would change based on exposure to different types of ELTS. Thermal stress did indeed alter preference; however, not in the way we had predicted. ELHS pigs preferred similar temperatures as ELTN and ELCS pigs. However, ELCS pigs demonstrated a warmer temperature preference when compared with ELTN pigs. These data supporting that early exposure to ELCS can alter pigs' temperature preference later in life.

Supplementary data

Supplementary data are available at *Journal of Animal Science* online

Funding

The authors would like to thank the swine farm staff at Purdue University for animal care especially Brian Ford, Katelin Ade, and Aaron Nally. Additionally, thank you to the employees at the USDA-ARS Livestock Behavior Research Unit, Christopher Gonzales, and undergraduate helpers Tiffany Wineinger and Carla Reyes Flores for assistance in daily animal care and data collection. Additional thank you to the Purdue University Statistical Consultation Service, specifically Bruce Craig and Daniel Vasquez Carvajal.

Mention of trade names or commercial products in this article is solely for the purpose of providing specific information and does not imply recommendation or endorsement by the U.S. Department of Agriculture or Purdue University.

Conflict of interest statement

The authors declare no real or perceived conflicts of interest.

Literature Cited

- Aarnink, A. J., J. W. Schrama, M. J. Heetkamp, J. Stefanowska, and T. T. Huynh. 2006. Temperature and body weight affect fouling of pig pens. *J. Anim. Sci.* **84**:2224–2231. doi:10.2527/jas.2005-521
- Bench, C. J., and H. W. Gonyou. 2007. Temperature preference in piglets weaned at 12–14 days of age. *Can. J. Anim. Sci.* **87**: 299–302. doi:10.4141/cjas06040
- Brown-Brandl, T. M., M. D. Hayes, H. Xin, J. A. Nienaber, and H. Li. 2014. Heat and moisture production of modern swine. *ASHRAE Trans.* **120**: 469–489. doi:10.13031/trans.57.1071
- Campbell, I. 2008. Body temperature and its regulation. *Anaest. Intens. Care Med.* **9**: 259–263. doi:10.1016/j.mpaic.2008.04.009
- Curtis, S. 1985. Physiological response and adaptation of swine in stress physiology in livestock. In: M.D. Yousef, ed. Vol. II: *ungulates*. Boca Raton, FL: CRC Press; p. 59–65 and 129–139.
- Dauncey, M. J., and D. L. Ingram. 1986. Acclimatization to warm or cold temperatures and the role of food intake. *J. Thermal Biol.* **11**: 89–93. doi:10.1016/0306-4565(86)90025-2
- DeShazer, J., and D. Overhults. 1982. Energy demand in livestock production. In: *Livestock environment II. Proceedings of 2nd International Livestock Environment Symposium*. St. Joseph, MI: ASAE; p. 17–27.
- Federation of Animal Science Societies. 2010. *Guide for the care and use of agricultural animals in research and teaching*. 3rd ed. Champaign, IL: Federation of Animal Science Societies. Chap. 11.
- Gaskill, B. N., C. J. Gordon, E. A. Pajor, J. R. Lucas, J. K. Davis, and J. P. Garner. 2012. Heat or insulation: behavioral titration of mouse preference for warmth or access to a nest. *PLoS One* **7**:e32799. doi:10.1371/journal.pone.0032799
- Gordon, C. J. 1993. *Temperature regulation in laboratory rodents*. New York: Cambridge University Press; p. 276.
- Grafen, A., and R. Hails. 2002. *Modern statistics for the life sciences*. Oxford, NY: Oxford University Press; p. 155–163.
- Hahn, G. 1985. Managing and housing of farm animals in hot environments in stress physiology in livestock. In: M. K. Yousef, ed. Vol. II: *ungulates*. Boca Raton, FL: CRC Press; p. 151–174.
- Harding, E. C., N. P. Franks, and W. Wisden. 2019. The temperature dependence of sleep. *Front. Neurosci.* **13**:336. doi:10.3389/fnins.2019.00336
- Heldmaier, G. 1974. Cold adaptation by short daily cold exposures in the young pig. *J. Appl. Physiol.* **36**:163–168. doi:10.1152/jappl.1974.36.2.163
- Horowitz, M. 2007. Heat acclimation and cross-tolerance against novel stressors: genomic–physiological linkage. *Prog. Brain Res.* **162**: 373–392. doi:10.1016/S0079-6123(06)62018-9
- Hrupka, B. J., V. D. Leibbrandt, T. D. Crenshaw, and N. J. Benevenga. 2000. Effect of sensory stimuli on huddling behavior of pigs. *J. Anim. Sci.* **78**:592–596. doi:10.2527/2000.783592x
- Huynh, T. T. T., A. J. A. Aarnink, W. J. J. Gerritsc, M. J. H. Heetkamp, T. T. Canhe, H. A. M. Spoolerdf, B. Kempd, and M. W. A. Verstegeenc. 2005. Thermal behaviour of growing pigs in response to high temperature and humidity. *Appl. Anim. Behav. Sci.* **91**: 1–16. doi:10.1016/j.applanim.2004.10.020
- Johnson, J. S., M. A. Aardsma, A. W. Duttlinger, and K. R. Kpodo. 2018. Early life thermal stress: Impact on future thermotolerance, stress response, behavior, and intestinal morphology in piglets exposed to a heat stress challenge during simulated transport. *J. Anim. Sci.* **96**:1640–1653. doi:10.1093/jas/sky107
- Johnston, I. A., and A. F. Bennett. 2008. *Animals and temperature: phenotypic and evolutionary adaptation*. Cambridge, NY: Cambridge University Press; p. 265–286.
- Kingma, B. R., A. J. Frijns, L. Schellen, and W. D. van Marken Lichtenbelt. 2014. Beyond the classic thermoneutral zone: including thermal comfort. *Temperature (Austin)*. **1**:142–149. doi:10.4161/temp.29702
- Kregel, K. C. 2002. Invited review: heat shock proteins: modifying factors in physiological stress responses and acquired thermotolerance. *J. Appl. Physiol.* (1985). **92**:2177–2186. doi:10.1152/japplphysiol.01267.2001
- Ledgerwood, D. N., C. Winckler, and C. B. Tucker. 2010. Evaluation of data loggers, sampling intervals, and editing techniques for measuring the lying behavior of dairy cattle. *J. Dairy Sci.* **93**:5129–5139. doi:10.3168/jds.2009-2945
- Mead, R. 1990. *The design of experiments: statistical principles for practical applications*. Cambridge, NY: Cambridge University Press; p. 620.
- Mount, L. 1960. The influence of huddling and body size on the metabolic rate of the young pig. *J. Agric. Sci.* **55**: 101–105. doi:10.1017/S0021859600021651
- Mount, L. E. 1963. The thermal insulation of the new-born pig. *J. Physiol.* **168**:698–705. doi:10.1113/jphysiol.1963.sp007216
- Newman, J. A., J. Bergelson, and A. Grafen. 1997. Blocking factors and hypothesis tests in ecology: is your statistics text wrong? *Ecology* **78**: 1312–1320. doi:10.1890/0012-9658(1997)078[1312:BFAHTI]2.0.CO;2
- NRC. 1981. *Effects of environment on nutrient requirements of domestic animals*. Washington, DC: National Academic Press.
- Pedersen, S., P. Sousa, L. Andersen, and K. H. Jensen. 2003. Thermoregulatory behaviour of growing–finishing pigs in pens with access to outdoor areas. *Agric. Eng. Int.: CIGR J* **5**.
- Robbins, L., A. R. Green-Miller, J. S. Johnson, C. Gonzales, and B. N. Gaskill. 2018. Thermocline design for thermal preference testing in piglets. In: 10th International Livestock Environment Symposium (ILES X). St. Joseph, MI: American Society of Agricultural and Biological Engineers; p. 1.
- Terrien, J., M. Perret, and F. Aujard. 2011. Behavioral thermoregulation in mammals: a review. *Front. Biosci. (Landmark Ed.)*. **16**:1428–1444. doi:10.2741/3797
- Tetievsky, A., and M. Horowitz. 2010. Posttranslational modifications in histones underlie heat acclimation-mediated cytoprotective memory. *J. Appl. Physiol.* (1985). **109**:1552–1561. doi:10.1152/japplphysiol.00469.2010