



The signal-to-cutoff ratios to predict HCV infection among people who inject drugs

Bing Chen¹ · Ling-yu Gao² · Zhong-hui Ma³ ·
Hao Chang⁴ · Li-jian Pei⁴ · Qiang Zhou¹ · Wen-ge Xing⁴

Received: 21 May 2022 / Accepted: 3 October 2022
© The Author(s), under exclusive licence to Indian Virological Society 2022

Abstract People who inject drugs (PWIDs) are primarily the high-risk population for HCV infection. This study aims to determine the optimal cut-off values for predicting HCV infection status based on the Signal-to-Cutoff (S/CO) ratio. In this study, a total of 719 PWIDs' samples were collected, and performed for screening test by ELISA assay, and followed by RIBA assay and NAT assay to detect HCV antibody and HCV RNA levels, respectively. The findings revealed that the prevalence of HCV infection among PWIDs was 54.66% (393/719), and the false-positive rate of HCV antibody detection by ELISA assay among PWIDs was only 3.85% (16/416). In addition, when the optimal cut-off value for S/CO ratio was 2.0, the sensitivity and specificity of HCV antibody were 100.00% and 93.55%, respectively. And when the optimal cut-off value for S/CO ratio was 21.36, the sensitivity and specificity of HCV RNA positive were 89.90% and 72.73%, respectively. In conclusion, the status of HCV infection can be predicted based on the S/CO ratios of the ELISA assay, which can improve diagnosis and facilitate timely treatment to effectively prevent the spread of HCV infection.

Keywords Hepatitis C virus · People who inject drugs · S/CO ratio · Anti-HCV

Introduction

Hepatitis C virus (HCV) infection has caused significant public health burden globally, with an estimated global prevalence of 3% [32], and approximately 71 million individuals chronically infected worldwide [29]. In addition, HCV infection is one of the major risk factors for hepatocellular carcinoma (HCC). Previous data revealed that 21% of new HCC cases and deaths were attributed to HCV infection [5, 7]. Moreover, the relative risk of developing HCC in HCV-infected individuals was 15–20 times higher than in uninfected individuals [9, 35, 11], which may be due to the fact that HCV Core protein can induce oxidative stress through various signaling molecular pathways, such as COX-2, iNOS, VEGF and other cytokines eventually lead to the occurrence of hepatocellular carcinoma [28]. However, the successful development of direct-acting antiviral drugs (DAA) is a significant milestone in the antiviral treatment of HCV infection. The sustained virological response among patients after DAA treatment can achieve a high degree, which can be higher than 95%. Therefore, it is currently considered that HCV infection is a clinically curable disease [2, 27]. To achieve the WHO's goal of eliminating HCV infection by 2030, there is an urgent need to screen high-risk population for early diagnosis and treatment to control HCV transmission, especially for high-risk population [14, 24]. HCV infection is usually silent for several decades, which means most infected individuals are asymptomatic, and may unaware of their HCV infection [30], it was estimated that only 20% patients with HCV infection have been diagnosed. In addition, people who inject drugs (PWIDs) are primarily

✉ Wen-ge Xing
xingwenge@sina.com

✉ Qiang Zhou
zhouqiang1973@163.com

¹ Clinical Laboratory, The Second Hospital of Anhui Medical University, Hefei, Anhui, China

² Institute of Dermatology, Chinese Academy of Medical Sciences and Peking Union Medical College, Nanjing, China

³ Department for Communicable and Endemic Disease Control and Prevention, Beijing Fangshan District Center for Disease Control and Prevention, Beijing, China

⁴ National HIV/HCV Reference Laboratory, Chinese Center for Disease Control and Prevention, Beijing, China

the high-risk population for HCV infection, and the prevalence ranges from 50 to 80% [12, 25]. Therefore, accurate, cost-effective, and efficient screening and test methods for HCV infection are essential for further treatment and can effectively control the HCV epidemic.

At present, the main diagnostic methods for HCV infection are serological tests to detect HCV specific antibodies and nucleic acid tests (NAT) to detect HCV RNA. And the detection of HCV antibodies by enzyme-linked immunosorbent assays (ELISA) has the advantages of high sensitivity and simple operation, and is widely used in clinical screening tests. But the ELISA method is susceptible to cross-reactivity with endogenous substances, resulting in high false positive rate, especially in low-prevalence populations [4, 10, 6]. Therefore, samples with ELISA reactivity results need to further use the recombinant immunoblot assay (RIBA) or the NAT assay to determine the HCV infection status. However, the HCV RIBA test and HCV NAT test are complicated, expensive, time-consuming, and require high experimental conditions and personnel, which are difficult for ordinary laboratories to meet. Therefore, several studies and Center for Disease and Control have recommended that the Signal-to-Cutoff(S/CO) ratio of an HCV antibody assay can be used for predicting HCV viremia [3, 16]. And the higher the S/CO ratio, the higher the positive predictive value and the higher the possibility of HCV infection. In this regard, in order to simplify the algorithm for diagnosing HCV infection, several studies have set the cut-off of the S/CO ratio to 3.8 or 8 [6, 17], suggesting that when the S/CO ratio of a sample is higher than the cut-off, it is considered as HCV infection. However, the effective cut-off value and performance of an anti-HCV reagent would vary based on the assay and the population, and need to be evaluated [21].

Thus, this study aimed to investigate the relationship between the S/CO ratio and the positive with HCV antibody among PWIDs, and the correlation between the S/CO ratio and the positive with HCV RNA, and determined the optimal cut-off values of the S/CO ratio of the anti-HCV assay in PWIDs, which used for predicting HCV infection.

Materials and methods

Patients

A total of 719 PWIDs individuals' serum samples that were requested for anti-HCV testing at the methadone outpatient in Yunnan province and Gansu province from January 1, 2019 to December 31, 2020, including 435 males and 284 females, were included in this study. The collected serum samples were stored at -80°C . This study was approved by the Ethics Committee of National Center for AIDS/STD

Prevention and Control, Chinese Center for Disease Control and Prevention.

Laboratory tests

HCV screening test was performed using the anti-HCV enzyme linked immunoassay (ELISA) assay (Beijing Wantai Biological, China). The test results were calculated as the signal to cut-off(S/CO) ratio, allowing assessment of changes in HCV antibody levels. If an S/CO ratio < 1.0 , it was regarded as negative, and ≥ 1.0 was considered as reactivity.

The samples with ELISA reactive results were continued to RIBA assay (MP Diagnostics, Singapore), which was used as a more specific supplementary test on specimens. The nitrocellulose strips of RIBA assay contain five recombinant HCV proteins, the Core, NS3-1, NS3-2, NS4, and NS5 regions of the HCV genome. For this assay, the intensities of colored bands on a nitrocellulose strip are proportional to amounts of bound antibody and graded as - (none), \pm and 1+ to 4+. The results of RIBA assay were interpreted by the intensity and profile of the reactive bands. And a positive result was considered as two HCV-specific bands with reactivities of at least 1+, a negative result was defined as the absence of a band with reactivity $\geq 1+$, and an indeterminate result was that only bands had reactivity $\geq 1+$, but not in accordance with the positive criteria, according to the manufacturer's instructions.

All samples were performed for HCV RNA diagnosis using real-time quantitative polymerase chain reaction (RT-PCR) assay (DaAn Gene, China). Nucleic acids of the samples were extracted, and added into the PCR reaction tube. The amplified fluorescence signals were detected by RT-PCR instrument (Bio-Rad CFX96, America), and the instrument automatically calculates viral load of the samples according to the manufacturer's instructions.

Interpretation

Patients that tested positive for HCV antibody and HCV RNA were considered as patients with active HCV infection. Negative HCV RNA with positive RIBA result were considered as patients with spontaneous HCV viral clearance. Positive HCV RNA with negative anti-HCV results were regarded as early HCV infection. And negative RIBA with positive ELISA results were regarded as biological false-positive anti-HCV results [10].

Statistical analyses

Statistical analysis was performed using GraphPad Prism 8.0 and MedCalc software. Quantitative variables were expressed as Mean \pm standard deviations (M \pm SD).

Differences between continuous variables were calculated using Student's t-test. The diagnostic capability of anti-HCV S/CO in identifying patients with positive HCV antibody and RNA were assessed using receiver operating characteristic (ROC) curves. The area under the ROC curves (AUC) was calculated, and the statistical significance of the difference from an AUC value of 0.5 was determined. $P < 0.05$ was considered as statistically significant.

Results

Test procedure and results of patient samples

Among 719 PWIDs samples, 416 (57.86%) yielded reactive results ($S/CO \geq 1.0$) and 303 (42.14%) yielded negative results ($S/CO < 1.0$) by ELISA assays. Moreover, the results of supplementary test by RIBA assays showed that of the 416 ELISA screening test reactivity samples, 393 (94.47%) were positive for HCV antibodies, 7 (2.68%) were indeterminate, and 16 (3.85%) were negative. In addition, HCV RNA results revealed that of the 400 HCV antibody positive or indeterminate samples, 315 (78.75%) were positive for HCV RNA and 85 (21.25%) were negative for HCV RNA. Furthermore, 6 (1.88%) out of 319 HCV antibody negatives were positive for HCV RNA, implying that 6 of the 319 individuals in this study had HCV acute early infection or immunodeficiency. The HCV test assays and test results were summarized in Fig. 1.

The relationship between distribution of S/CO ratio and HCV antibody result

Among the 719 PWIDs samples in this study, when the S/CO ratio < 1.0 , 303 HCV antibodies were all negative, and when the S/CO ratio ≥ 1.0 , 16 of the 416 samples were confirmed to be antibody negative by the RIBA assays, indicating that 16 samples may be false positive results of ELISA assays (see Fig. 2). Moreover, ROC curve analysis was performed on the HCV ELISA assay in this study to determine the optimal S/CO ratio for HCV antibody positive, which is utilized to predict the positive result of HCV antibody. It showed that when the optimal cut-off value for S/CO ratio was 2.0, the sensitivity and specificity were 100.00% and 93.55%, respectively. And AUC was 0.985(95% confidence interval:0.971–0.994) (see Fig. 3).

The correlation between the S/CO ratio and HCV RNA result

Furthermore, we performed ROC curve analysis on the HCV ELISA assay in this study to determine the optimal S/CO ratio for HCV RNA positive, which is used for predicting the positive result of HCV RNA. It showed that when the optimal cut-off value for S/CO ratio was 21.36, the sensitivity and specificity were 89.90% and 72.73%, respectively. And AUC was 0.836 (95% confidence interval:0.802–0.867) (see Fig. 4). In addition, we also analyzed the correlation between the S/CO ratios and the HCV RNA levels, and found that there was no significant correlation between the S/CO ratios and the HCV RNA levels ($R^2 = 0.0008$, $P = 0.6214 > 0.05$) (see Fig. 5).

Fig. 1 Schematic diagram of the HCV detection methods and sample number. 719 PWIDs samples were collected for screening test by ELISA assays, and then supplementary test by RIBA assay and NAT assay to determine the status of HCV infection

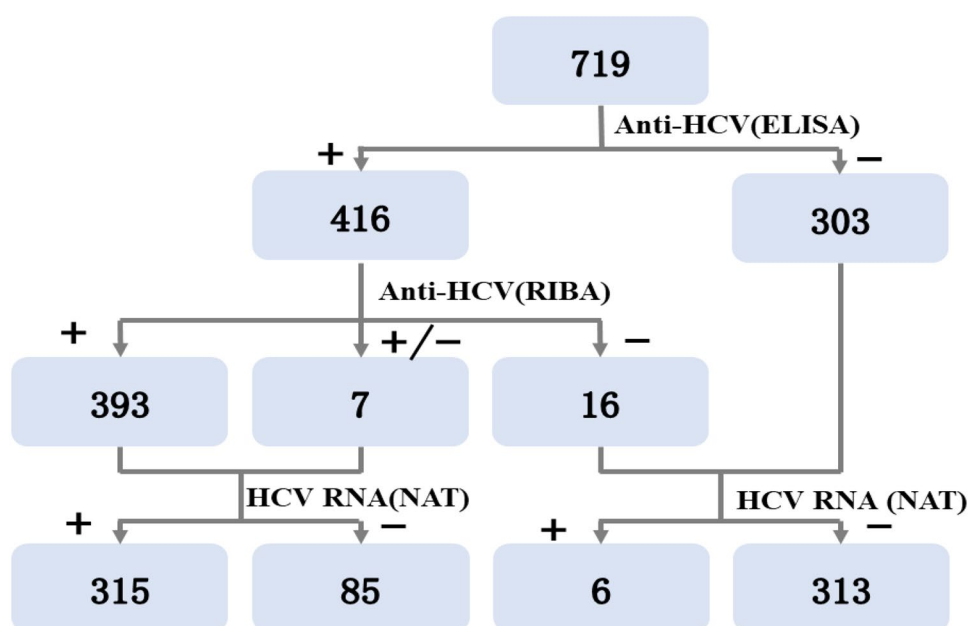

Fig. 2 The distribution of the S/CO ratios in 719 PWIDs samples using ELISA assay. The reported results were based on the RIBA assay and NAT assay to determine the HCV antibody results

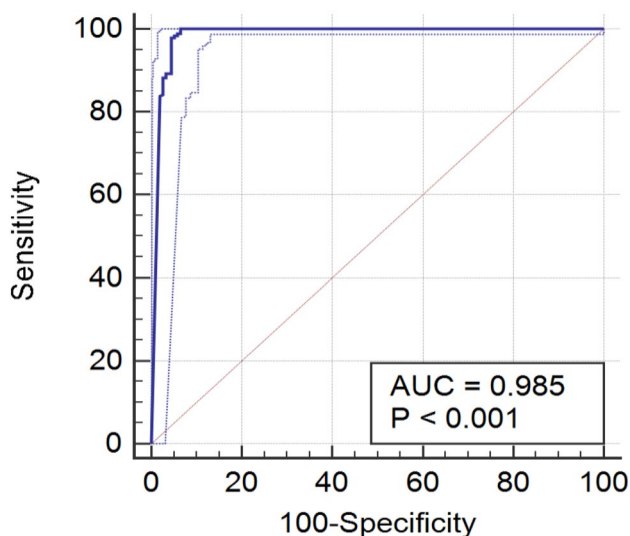
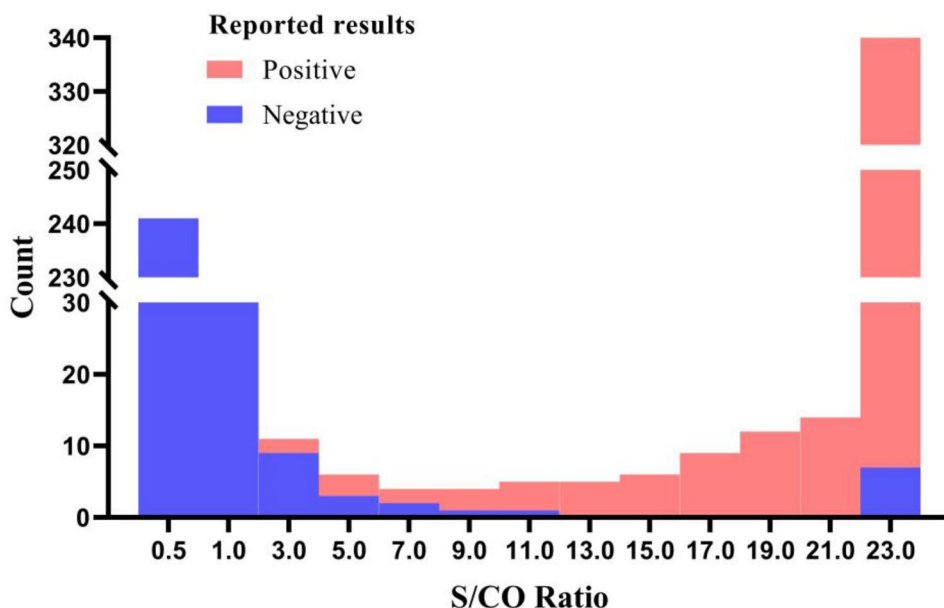

Fig. 3 Receiver operating curves (ROC) of S/CO ratio for predicting the positive result of HCV antibody in 719 PWIDs samples

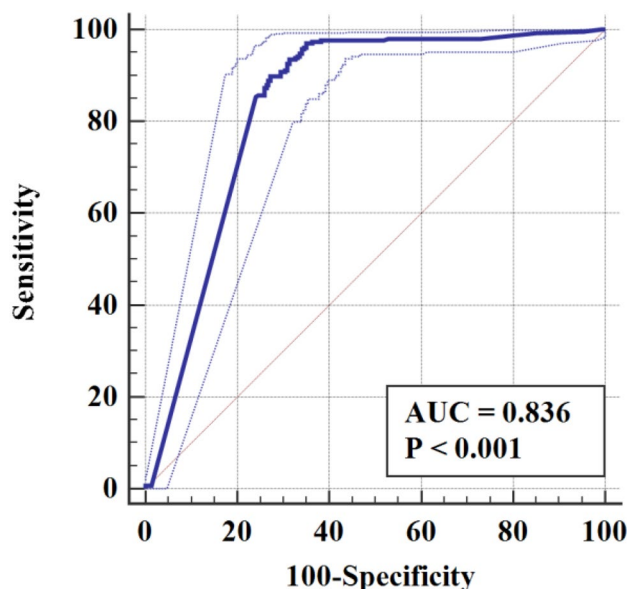

Fig. 4 Receiver operating curves (ROC) of S/CO ratio for predicting the positive result of HCV RNA in 719 PWIDs samples

Comparison of S/CO ratios between patients with spontaneous HCV viral clearance and patients with active HCV infection

Previous literature has indicated that HCV spontaneous clearance range from 15 to 60% [31]. However, the findings of this study revealed that 85 out of 400 PWIDs were HCV antibody positive but HCV RNA negative, indicating that they were patients with HCV spontaneous clearance. And 315 samples out of 400 were positive for HCV antibody and RNA, which means that they were patients with active HCV infection. In addition, this study found that there was a significant

difference in the S/CO ratios between patients with HCV spontaneous clearance and patients with active HCV infection ($P=0.0061 < 0.05$), and the S/CO ratio of patients with active HCV infection was significantly higher than that of patients with HCV spontaneous clearance ($22.23 \pm 4.51, 20.50 \pm 6.16$) (Fig. 6).

Fig. 5 Scatter plots between S/CO ratio and HCV RNA level. HCV RNA level was analyzed in log scale

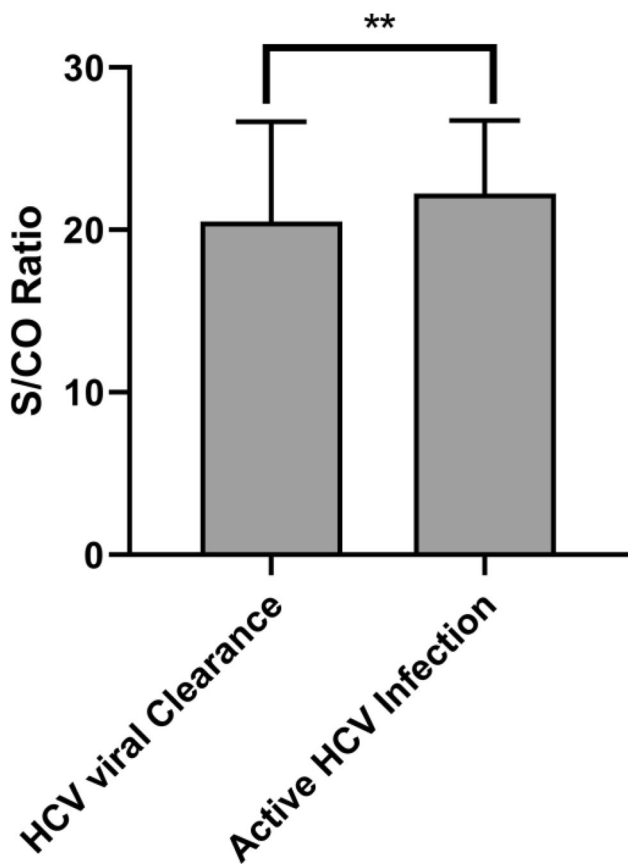
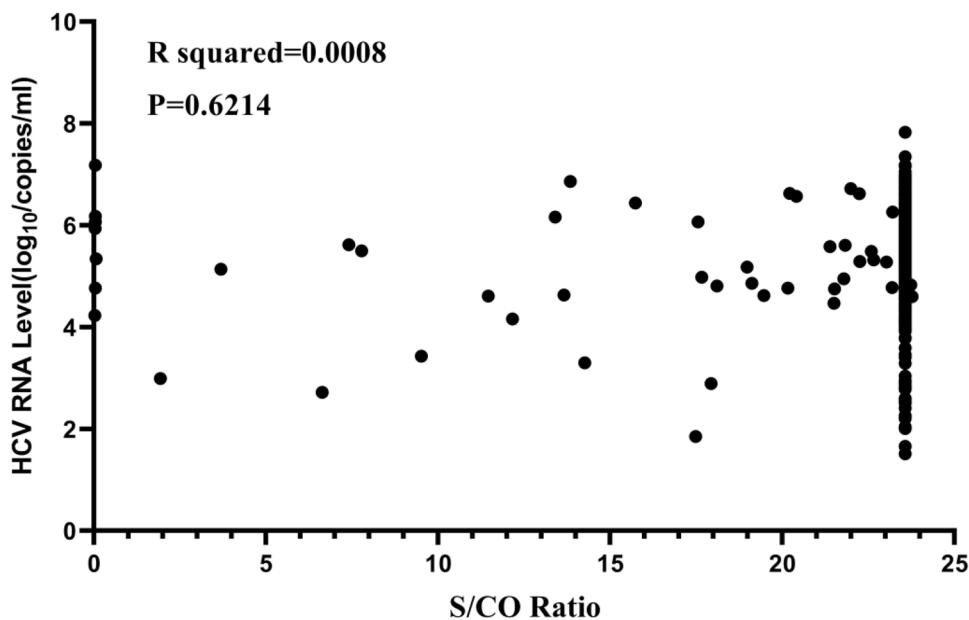

Fig. 6 Comparison of S/CO ratios between patients with active HCV infection and patients with HCV spontaneous clearance. Mean ± Standard Deviation, **: $P < 0.01$

Discussion

People who inject drugs (PWIDs) is the primary risk factors for HCV epidemic in many countries. Studies have shown that the number of people with HCV infection who are infected by injecting drugs is gradually increasing [8, 33]. It is estimated that there are about 14 million PWIDs in the world [23], and the prevalence of HCV infection among PWIDs approximately ranges from 50% to more than 80% [12, 25]. In this study, the result revealed that the prevalence of HCV infection among PWIDs was 54.66% (393/719), which was comparable to the infection reported in the previous literatures [8, 15]. Therefore, PWIDs are at high risk of HCV infection, which is much higher than the prevalence of HCV infection in the general population. In order to control the spread of HCV, it is vital to strengthen the large-scale HCV screening and effective treatment among PWIDs.

ELISA is currently one of the most commonly used methods for screening tests of HCV antibody, due to its simple operation and low price. According to the Chinese Centers for Disease Control and Prevention (CDC) for “Hepatitis C Virus Laboratory Testing Technical Specifications”, when the ELISA results were reactive, it was recommended that the samples need to be further supplementary test by HCV RIBA assay, which detect whether the HCV antibody is positive, but the RIBA assay is time-consuming and expensive. Herein, we analyzed the relationship between the ELISA S/CO ratio and the RIBA results in this study, and the results showed that when the S/CO ratio ≥ 1.0 , 16 of the 416 samples were confirmed to be antibody negative by the RIBA assays, indicating that the false-positive rate of HCV antibody detection by ELISA assay among PWIDs was only 3.85% (16/416), which was much lower than the

false-positive rate of 15–60% in the general population [19]. At the same time, the selected ELISA assay in this study was in good agreement with the RIBA assay. The ELISA reagents are coated with multiple antigens, including the core antigen, NS3 antigen, NS4 antigen and NS5 epitope, leading to excellent specificity and sensitivity. On the other hand, the subjects of this study were PWIDs, who have a high prevalence of HCV infection. Hence the probability of false-positive is lower.

In addition, in this study, we analyzed the optimal cut-off value of S/CO ratio by using ROC curve to predict HCV antibody results. According to the ROC curve, it demonstrated that when the optimal cut-off value was 2.0, the sensitivity and specificity of anti-HCV were 100.00% and 93.55%, respectively, implying that the S/CO ratio of this ELISA test can effectively distinguish HCV antibody positive and antibody negative in PWIDs. However, several studies have also analyzed the optimal cut-off value of S/CO ratio to distinguish the status of HCV infection, and the recommended cut-off values were ranging from 6 to 8 [4, 13, 34]. Differences in research population, sample size, and reagents might explain the disparity in cut-off values. Jie Pan, et al. and Banseok Kim, et al. reported that compared with RIBA results, the optimal S/CO ratios of Elecsys anti-HCV reagent by using ROC curve and regression analysis range from 12.27 to 19.00 in the low-risk population [17, 26]. While Hung-Yin Liu, et al. demonstrated that the optimal cut-off for predicting HCV infection was 9.95 in HBV infected patients [21]. As a consequence, we may utilize the optimal cut-off value of the S/CO ratio to predict the result of HCV antibody, although the optimal cut-off value of different populations and reagents may be inconsistent.

Furthermore, only individuals with HCV RNA positive need DAA treatment. However, not all patients with HCV antibody positive can be detected HCV RNA, because 15–60% of HCV infected patients can clear the virus spontaneously [31]. In this study, 21.25% (85/400) of infected individuals had spontaneous HCV viral clearance, and the other 78.75% (315/400) of patients were active HCV infection. In order to promptly identify whether the individuals have spontaneous HCV virus clearance or active HCV infection, several studies have shown that high HCV antibody levels can predict HCV virus. We also analyzed the optimal cut-off value of S/CO ratio by using ROC curve to predict HCV viremia [17, 21, 18]. The results demonstrated that when the optimal cut-off value for S/CO ratio was 21.36, the sensitivity and specificity were 89.90% and 72.73%, respectively, indicating that the serum anti-HCV titers in PWIDs have a good predictive value for HCV RNA positivity, which is consistent with previous literature [13]. We analyzed the correlation between the HCV ELISA S/CO ratios and the HCV RNA levels, and found that there was no significant correlation. Several studies also revealed that

anti-HCV titers and HCV RNA levels show little or weak correlation [17]. However, there was a significant difference in the S/CO ratios between patients with HCV spontaneous clearance and patients with active HCV infection, and the S/CO ratio of patients with active HCV infection was significantly higher than that of patients with HCV spontaneous clearance. The reason for this phenomenon might be that the HCV antibodies are produced in the patient's body by stimulation of HCV antigen components, and antibodies titers seem to be increased when antigens are continuously stimulated. Therefore, compared to patients with HCV spontaneous clearance, patients with active HCV infection have strong and persistent HCV antigen stimulation, which results in a higher anti-HCV S/CO ratio.

Moreover, in this study, we also found that 6 out of 319 HCV antibody-negative samples were positive for HCV RNA. The possible reasons for this phenomenon are that, on the one hand, although HCV antibodies are widely used in screening tests, the HCV antibody test may not be positive in the early stage of acute infection that is up to 30–60 days after exposure [1]. Therefore, these 6 patients might be in the early stage of acute HCV infection. On the other hand, it is also possible that some individuals with immunodeficiency or immunosuppressive therapy cannot produce antibodies, resulting in negative HCV antibody but positive HCV RNA. Therefore, a negative HCV antibody can't rule out HCV infection [20]. And early detection and curative treatment of HCV can will reduce the risk of liver-related mortality and serve to prevent transmission of new infections [22]. It is suggested that the samples with negative results of HCV antibody detection in high-risk population should be tested by pool PCR to prevent the missed detection.

However, there are still several limitations in this study. First of all, this study only included methadone outpatients in two regions of China. Although the collected samples were large, it still didn't fully represent the prevalence of HCV infection among PWIDs in my country. In addition, this study only selected one ELISA reagent to detect the distribution of HCV S/CO ratios in PWIDs, and did not analyze the optimal cut-off value of other reagents of screening test. And the optimal cut-off value for other reagents may be different, so other reagents are further determining the optimal cut-off value for reflex supplemental testing according to the population screened.

Conclusions

This study has showed that the S/CO ratios of the ELISA assay are associated with the results of HCV antibody and HCV RNA among PWIDs. When the S/CO ratios of the samples from PWIDs are higher than the optimal cut-off value of 2.0 and 21.36, respectively, it can be considered that

the patients are HCV antibody positive and HCV RNA positive. In addition, the S/CO ratio of patients with active HCV infection is higher than that of patients with spontaneous HCV clearance. Therefore, the status of HCV infection can be predicted based on the S/CO ratios of the ELISA assay, which can improve diagnosis and facilitate timely treatment to effectively prevent the spread of HCV infection.

Acknowledgements We thank Prof. Ling Pang and the staff of Gansu CDC and Yunnan CDC for helping to collect samples, and also thank Ms. Dan-zhao Xiao and Dr. Rui Shen for her assistance in experimental testing.

Declarations

Ethics approval and consent to participate The study and all experimental protocols were approved by the Ethics Committee of National Center for AIDS/STD Prevention and Control, Chinese Center for Disease Control and Prevention (Number #X150619379). And all methods were carried out in accordance with relevant guidelines and regulations. And all participants have agreed to participate in this study and have obtained informed consent from all subjects and/or their legal guardians.

Conflict of interest The authors declare that they have no conflict of interest.

References

1. Aebi-Popp K, Wandeler G, Salazar-Vizcaya L, Metzner K, Stockle M, Cavassini M, et al. Rapid decline of anti-hepatitis C virus (HCV) antibodies following early treatment of incident HCV infections in HIV-infected men who have sex with men. *HIV Med.* 2018;19(6):420–5.
2. Aghemo A, Buti M. Hepatitis C, Therapy. *Game Over! Gastroenterology.* 2016;151(5):795–8.
3. Alborino F, Burighel A, Tiller FW, van Helden J, Gabriel C, Raineri A, et al. Multicenter evaluation of a fully automated third-generation anti-HCV antibody screening test with excellent sensitivity and specificity. *Med Microbiol Immunol.* 2011;200(2):77–83.
4. Alter MJ, Kuhnert WL, Finelli L, Centers for Disease C, Prevention. Guidelines for laboratory testing and result reporting of antibody to hepatitis C virus. *Centers for Disease Control and Prevention. MMWR Recomm Rep.* 2003;52(RR-3):1–13. 15; quiz CE11–14.
5. Baecker A, Liu X, La Vecchia C, Zhang ZF. Worldwide incidence of hepatocellular carcinoma cases attributable to major risk factors. *Eur J Cancer Prev.* 2018;27(3):205–12.
6. Choi MS, Lee K, Hong YJ, Song EY, Kim DS, Song J. The role of the signal-to-cutoff ratio in automated anti-HCV chemiluminescent immunoassays by referring to the nucleic acid amplification test and the recombinant immunoblot assay. *Ann Lab Med.* 2018;38(5):466–72.
7. de Martel C, Georges D, Bray F, Ferlay J, Clifford GM. Global burden of cancer attributable to infections in 2018: a worldwide incidence analysis. *Lancet Glob Health.* 2020;8(2):e180–90.
8. Degenhardt L, Peacock A, Colledge S, Leung J, Grebely J, Vickerman P, et al. Global prevalence of injecting drug use and sociodemographic characteristics and prevalence of HIV, HBV, and HCV in people who inject drugs: a multistage systematic review. *Lancet Glob Health.* 2017;5(12):e1192–207.
9. Donato F, Tagger A, Gelatti U, Parrinello G, Boffetta P, Albertini A, et al. Alcohol and hepatocellular carcinoma: the effect of lifetime intake and hepatitis virus infections in men and women. *Am J Epidemiol.* 2002;155(4):323–31.
10. Dufour DR, Talastas M, Fernandez MD, Harris B. Chemiluminescence assay improves specificity of hepatitis C antibody detection. *Clin Chem.* 2003;49(6 Pt 1):940–4.
11. El-Serag HB. Epidemiology of viral hepatitis and hepatocellular carcinoma. *Gastroenterology.* 2012;142(6):1264–73. e1261.
12. Falade-Nwulia O, Hackman J, Mehta SH, McCormick SD, Kirk GD, Sulkowski M, et al. Factors associated with phylogenetic clustering of hepatitis C among people who inject drugs in Baltimore. *BMC Infect Dis.* 2020;20(1):815.
13. Ha J, Park Y, Kim HS. Signal-to-cutoff ratios of current anti-HCV assays and a suggestion of new algorithm of supplementary testing. *Clin Chim Acta.* 2019;498:11–5.
14. Hariri S, Sharafkhan M, Alavi M, Roshandel G, Fazel A, Amiriani T, et al. A simple risk-based strategy for hepatitis C virus screening among incarcerated people in a low- to middle-income setting. *Harm Reduct J.* 2020;17(1):56.
15. Kaberg M, Naver G, Hammarberg A, Weiland O. Incidence and spontaneous clearance of hepatitis C virus (HCV) in people who inject drugs at the Stockholm Needle Exchange-Importance for HCV elimination. *J Viral Hepat.* 2018;25(12):1452–61.
16. Kim S, Kim JH, Yoon S, Park YH, Kim HS. Clinical performance evaluation of four automated chemiluminescence immunoassays for hepatitis C virus antibody detection. *J Clin Microbiol.* 2008;46(12):3919–23.
17. Kim B, Ahn HJ, Choi MH, Park Y. Retrospective analysis on the diagnostic performances and signal-to-cut-off ratios of the Elecsys Anti-HCV II assay. *J Clin Lab Anal.* 2018;32(1):e22165.
18. Kirisci O, Caliskan A. Threshold value of the anti-HCV test in the diagnosis of HCV infection. *J Infect Dev Ctries.* 2019;13(10):914–9.
19. Kodani M, Martin M, de Castro VL, Drobeniuc J, Kamili S. An automated immunoblot method for detection of IgG antibodies to hepatitis C virus: a potential supplemental antibody confirmatory assay. *J Clin Microbiol.* 2019;57(3):e01567–18.
20. Kumar R, Chan KP, Ekstrom VSM, Wong JCC, Lim KL, Ng WC, et al. Hepatitis C virus antigen detection is an appropriate test for screening and early diagnosis of hepatitis C virus infection in at-risk populations and immunocompromised hosts. *J Med Virol.* 2021;93(6):3738–43.
21. Liu HY, Lin YH, Lin PJ, Tsai PC, Liu SF, Huang YC, et al. Anti-HCV antibody titer highly predicts HCV viremia in patients with hepatitis B virus dual-infection. *PLoS ONE.* 2021;16(7):e0254028.
22. Mane A, Sacks J, Sharma S, Singh H, Tejada-Strop A, Kamili S, et al. Evaluation of five rapid diagnostic tests for detection of antibodies to hepatitis C virus (HCV): a step towards scale-up of HCV screening efforts in India. *PLoS ONE.* 2019;14(1):e0210556.
23. Midgard H, Weir A, Palmateer N, Lo Re V 3rd, Pineda JA, Macias J, et al. HCV epidemiology in high-risk groups and the risk of reinfection. *J Hepatol.* 2016;65(1 Suppl):33–45.
24. Moradi G, Gouya MM, Azimzhan Zavareh F, Mohamadi Bolbanabad A, Darvishi S, Aghasadeghi MR, et al. Prevalence and risk factors for HBV and HCV in prisoners in Iran: a national bio-behavioural surveillance survey in 2015. *Trop Med Int Health.* 2018;23(6):641–9.
25. Nic An Riogh E, Swan D, McCombe G, O'Connor E, Avramovic G, Macias J, et al. Integrating hepatitis C care for at-risk groups (HepLink): baseline data from a multicentre feasibility study in primary and community care. *J Antimicrob Chemother.* 2019;74(Suppl 5):v31–8.
26. Pan J, Li X, He G, Yuan S, Feng P, Zhang X, et al. Reflex threshold of signal-to-cut-off ratios of the Elecsys anti-HCV

- II assay for hepatitis C virus infection. *J Infect Dev Ctries.* 2016;10(9):1031–4.
27. Peng P, Xu Y, Fried MW, Di Bisceglie AM, Fan X. Genome-wide capture sequencing to detect hepatitis C virus at the end of antiviral therapy. *BMC Infect Dis.* 2020;20(1):632.
 28. Penin F, Dubuisson J, Rey FA, Moradpour D, Pawlotsky JM. Structural biology of hepatitis C virus. *Hepatology.* 2004;39(1):5–19.
 29. Polaris Observatory HCVC. Global prevalence and genotype distribution of hepatitis C virus infection in 2015: a modelling study. *Lancet Gastroenterol Hepatol.* 2017;2(3):161–76.
 30. Proute M, Le Coeur S, Tiv MH, Dub T, Jongpaijitsakul P, Ratnamhin A, et al. Risky injection practices and HCV awareness in Chiang Mai Province, Thailand: a respondent-driven sampling study of people who inject drugs. *BMC Public Health.* 2020;20(1):1450.
 31. Seo S, Silverberg MJ, Hurley LB, Ready J, Saxena V, Witt D, et al. Prevalence of spontaneous clearance of hepatitis C virus infection doubled from 1998 to 2017. *Clin Gastroenterol Hepatol.* 2020;18(2):511–3.
 32. Sung PS, Hong SH, Chung JH, Kim S, Park SH, Kim HM, et al. IFN-lambda4 potently blocks IFN-alpha signalling by ISG15 and USP18 in hepatitis C virus infection. *Sci Rep.* 2017;7(1):3821.
 33. Tao YL, Tang YF, Qiu JP, Cai XF, Shen XT, Wang YX, et al. Prevalence of hepatitis C infection among intravenous drug users in Shanghai. *World J Gastroenterol.* 2013;19(32):5320–5.
 34. Tiwari AK, Pandey PK, Negi A, Bagga R, Shanker A, Baveja U, et al. Establishing a sample-to cut-off ratio for lab-diagnosis of hepatitis C virus in Indian context. *Asian J Transfus Sci.* 2015;9(2):185–8.
 35. Yi SW, Choi JS, Yi JJ, Lee YH, Han KJ. Risk factors for hepatocellular carcinoma by age, sex, and liver disorder status: a prospective cohort study in Korea. *Cancer.* 2018;124(13):2748–57.

Publisher's Note Springer Nature remains neutral with regard to jurisdictional claims in published maps and institutional affiliations.

Springer Nature or its licensor (e.g. a society or other partner) holds exclusive rights to this article under a publishing agreement with the author(s) or other rightsholder(s); author self-archiving of the accepted manuscript version of this article is solely governed by the terms of such publishing agreement and applicable law.