

Review

Hereditary Non-Polyposis colon cancer

LA Devlin, JH Price, PJ Morrison

INTRODUCTION

Colorectal cancer is the second most common cause of cancer related death and the third most common cancer in the United Kingdom.^{1, 2} Around 80% of cases present with spread to the bowel wall. Early diagnosis and recognition of symptoms can now be achieved by screening asymptomatic persons.³

We now know that between 5-15% of colorectal cancer is hereditary in nature. Various genetic disorders exist that predispose individuals to colorectal cancer (CRC), including Familial Adenomatous Polyposis (Gardner's syndrome, Turcot's syndrome), Peutz-Jeghers syndrome, Juvenile Polyposis syndrome and Hereditary Non Polyposis Colorectal Cancer (HNPCC).

This is an autosomal dominant highly penetrant cancer-susceptibility syndrome caused by germline mutations in one of the DNA mismatch repair genes, MLH1, MSH2, MSH6, PMS2 and PMS1. Affected individuals have a predisposition to developing early onset colorectal cancer and endometrial cancer, and less commonly ovarian, small intestine, stomach, biliary tract, pancreatic, brain and uroepithelial tract cancer.

In contrast to Familial adenomatous polyposis and other colorectal cancer syndromes, HNPCC lacks distinctive clinical features. Traditionally associated with an increased susceptibility to CRC, the extending clinical phenotype with a susceptibility to other cancers makes diagnosis increasingly difficult. Under-diagnosis leaves families susceptible to cancer, whereas over diagnosis commits families to a prolonged screening program that is not without its complications.

Various criteria have been developed to aid in the diagnosis of HNPCC and select families for molecular testing of mismatch repair genes, the Amsterdam and Bethesda criteria being the most widely used (Boxes 1-3). Difficulties arise in families

who do not meet these criteria, but have a significant history of HNPCC related cancers.

HISTORICAL BACKGROUND

One of the first HNPCC families described was "Family G", by Warthin in 1913.⁴ Warthin's interest in the hereditary nature of certain cancers was stimulated by the depressed thoughts from his seamstress who had told him that she would die at an early age from cancer of the colon, or cancer of the female organs, as had many of her relatives. He analysed 3600 cases of neoplasm at the pathological laboratory of the University of Michigan between the years of 1895 to 1913. From looking at family histories he identified those with multiple occurrence of carcinoma. The incidence of cancer in these families was so striking that he interpreted them as showing an inherited susceptibility to cancer.

His seamstress later died of endometrial carcinoma, but her family, "Family G" showed a predominance of uterine, gastric and colon cancer. Warthin's study looked at three successive generations; forty-eight descendants of a grandfather with cancer of the stomach/intestine. Ten cases of carcinoma of the uterus and seven of the stomach were described.

He noted that uterus, breast, gastrointestinal tract and mouth are the parts of the body most frequently involved in the case of these family cancers. Cancer

Belfast City Hospital, Lisburn Road, Belfast BT9 7AB.

Department of Medical Genetics:

LA Devlin, MB, BCh, MRCPCH, Research Fellow.

PJ Morrison, MD, FRCPCH, FFPHMI, Professor of Human Genetics.

Department of Gynaecological Surgery:

JH Price, MD, FRCOG, Consultant Gynaecologist.

Correspondence to Professor Morrison.

of the lip and rodent ulcer of the face also show a tendency to familial occurrence.

Lynch revisited the family in the 1960's,⁵ with more than 650 descendants. He noted the increased incidences of adenocarcinoma, predominantly of the colon and endometrium. One particular branch of the family (from a sibship of ten, from the original progenitor) initially showed a paucity of cancer until further generations developed chronic lymphocytic leukaemia and lymphosarcoma (3 out of seven members of a sibship).

Several members of the other branches of the family also developed chronic lymphocytic leukaemia, sarcomas and brain tumours.

Lynch concluded that the cancer family syndrome was characterised by: (1) increased occurrences of adenocarcinoma, primarily of the colon and endometrium; (2) increased incidence of multiple primary malignant neoplasms; (3) autosomal dominant inheritance; and (4) early age of onset of cancer. "Family G" differed from other families with the cancer family syndrome in the development of sarcomas and leukaemias in some family members.

He named the purely colon type 'Lynch type 1' and families with extra colonic cancers including ovarian and endometrial, 'Lynch type 2'. We now know that several genes cause the different phenotypes and the term HNPCC is generally used.

MOLECULAR GENETICS

HNPCC is caused by mutations in mismatch repair genes, MLH1, MSH2, MSH6, PMS2 and PMS1. MLH1 and MSH2 account for the majority of families with HNPCC. The prevalence of mutations in these two genes in HNPCC families depends on the chosen population and inclusion criteria used for molecular screening, but can be as high as 86%.⁶ Founder effects in this Finnish population may account for the relatively high mutation detection rate and the prevalence of MLH1 and MSH2 mutations in other HNPCC kindreds meeting the Amsterdam criteria have been 39-49%.^{7,8} The same studies found the prevalence of MLH1 and MSH2 mutations in kindreds who are "Amsterdam Like", showing familial clustering of colorectal and other related cancers, to be between 8 and 16.7%, depending on the specific subgroup tested. The population carrier frequencies of MLH1 and MSH2 have been estimated at 1:3139 in the Scottish population.⁹

Recently, it has been noted that large genomic rearrangements, that traditionally would not be picked up on genomic sequencing, account for more than 50% of pathogenic mutations in MLH1/MSH2 in families meeting the Amsterdam criteria.¹⁰

MSH6 mutations are less common; 3.8% of total families, and 14.7% of all families with DNA mismatch repair gene mutations in a German HNPCC cohort,¹¹ had MSH6 gene mutations. They had a later age of disease onset and a lower incidence of CRC, hence almost two-thirds of families carrying MSH6 mutations would have been missed if the Amsterdam criteria were applied as a 'checklist' to be met prior to molecular testing.

A deletion in PMS2 and one nonsense mutation in PMS1 have been described in HNPCC families,¹² however a more recent study by Liu *et al*¹³ failed to identify any clear cut pathogenic mutations in 84 HNPCC and HNPCC like kindreds without known mutations in the other three known DNA mismatch repair genes.

At present, testing in the NHS is offered on a diagnostic basis for germline mutations in MLH1 and MSH2 to families fulfilling the modified Amsterdam criteria in most regions.

Molecular analysis of these mismatch repair genes is expensive and very labour intense; therefore selection of families for molecular analysis of MLH1 and MSH2 must be aimed at those likely to have a mutation in either of the two genes.

No definite criteria exist for the diagnosis of HNPCC and there are various factors that will influence the likelihood of a mutation in one of the mismatch repair genes known to be involved.

DIAGNOSTIC CRITERIA

The Amsterdam criteria were developed in 1991 by the International Collaborative Group on Hereditary Non-polyposis Colorectal Cancer (ICG-HNPCC),¹⁴ in an attempt to standardise diagnostic criteria in recruitment of HNPCC patients for comparative multicentre studies. These were modified in 1999 to include other HNPCC related cancers.¹⁵

Since then, the Amsterdam criteria have been commonly used to diagnose HNPCC and to select families for molecular analysis of mismatch repair genes.

Application of the Amsterdam criteria to molecular testing will increase the chance of a germline mutation in MSH2 and MLH1, but may indeed

miss a significant number of families carrying an MSH6 mutation.

Box 1:

Amsterdam criteria I

There should be at least three relatives with histologically verified CRC; all of the following criteria should be present:

One should be a first degree relative of the other two:

At least two successive generations should be affected:

At least one CRC should be diagnosed before age 50:

FAP should be excluded in the CRC case:

Tumours should be verified by pathological examination.

Box 2:

Modified Amsterdam criteria (Amsterdam II)

There are at least three relatives with an HNPCC associated cancer (large bowel, endometrium, small bowel, ureter, or renal pelvis, though not including stomach ovary, brain, bladder or skin):

One affected person is a first degree relative of the other two:

At least two successive generations are affected:

At least one person was diagnosed before the age of 50 years:

Familial adenomatous polyposis has been excluded:

Tumours have been verified by pathological examination.

MICROSATELLITE INSTABILITY (MSI) AND IMMUNOHISTOCHEMISTRY (IHC)

Microsatellite instability is characteristic of tumours from individuals with a mutation in one of the mismatch repair genes. These are length variations of short repetitive DNA sequences in the tumour, and occur in more than 80% of HNPCC tumours. As many as 15% of sporadic colorectal cancer also display MSI.¹⁶

MSI can therefore be used as a screening tool to try and identify patients who are likely to have a mutation in one of these genes. The Bethesda

guidelines were introduced in 1997¹⁷ to indicate which families should proceed to MSI testing prior to molecular analysis (Box 3).

These Bethesda Guidelines were revised in relation to their performance, sensitivity and specificity in 2002, following a HNPCC workshop at the National Cancer Institute, Bethesda, MD,¹⁸ (Box 4).

Box 3:

The Bethesda criteria for MSI testing of tumours: tumours from any of the following should be tested for MSI (or by immunohistochemistry) and then positive patients should continue for MMR testing.

Individuals with cancer in families that meet the Amsterdam Criteria:

Individuals with two HNPCC-associated cancers, including synchronous and metachronous CRC or associated extracolonic cancers:

Individuals with CRC and a first-degree relative with CRC and/or HNPCC-related extracolonic cancer and/or a colorectal adenoma diagnosed at age < 40 years:

Individuals with CRC or endometrial cancer diagnosed at age < 45 years:

Individuals with right sided CRC with an undifferentiated pattern (solid or cribriform) on histopathology diagnosed at age < 45 years:

Individuals with signet-ring-cell-type CRC diagnosed at age < 45 years:

Individuals with adenomas diagnosed at age < 40 years.

Immunohistochemical loss of expression of the affected MMR protein is another characteristic feature of HNPCC tumours. This too can be used as a screening, in combination with MSI, prior to molecular testing.

MSI and IHC have both been shown to be highly sensitive and specific in predicting a germline mutation (97 and 83% respectively for MSI, 79 and 89% respectively for IHC),¹⁹ and are reliable to be used to identify patients suitable for molecular analysis, in patients suspected of HNPCC.²⁰ Tumours resulting from a germline mutation in MSH6 may exhibit a lower degree of MSI,²¹ and therefore an MSI-low phenotype cannot be considered an exclusion criterion for mutation testing of MSH6.

Box 4:

Revised Bethesda Guidelines for testing colorectal tumours for microsatellite instability (MSI).

Tumours from individuals should be tested for MSI in the following situations:

- 1) Colorectal cancer diagnosed in a patient who is less than 50 years of age.
- 2) Presence of synchronous, metachronous colorectal, or other HNPCC associated tumours*, regardless of age.
- 3) Colorectal cancer with the MSI-H† histology‡ diagnosed in a patient who is less than 60 years of age.
- 4) Colorectal cancer diagnosed in one or more first degree relatives with an HNPCC-related tumour, with one of the cancers being diagnosed less than 50 years.
- 5) Colorectal cancer diagnosed in two or more first- or second-degree relatives with HNPCC-related tumours, regardless of age.

* HNPCC related tumours include colorectal, endometrial, stomach, ovarian, pancreas, ureter and renal pelvis, biliary tract, and brain (usually glioblastoma as seen in Turcot syndrome) tumours, sebaceous gland adenomas and keratoacanthomas in Muir-Torre syndrome, and carcinoma of the small bowel.

† MSI-H = microsatellite instability-high in tumours refers to changes in two or more of the five National Cancer Institute-recommended panels of microsatellite markers.

‡ Presence of tumour infiltrating lymphocytes, Crohn's-like lymphocytic reactions, mucinous/signet-ring differentiation, or medullary growth pattern.

_ There was no consensus among the Workshop participants on whether to include the age criteria in guideline 3 above; participants voted to keep less than 60 years of age in the guidelines.

A review carried out by Grady calculated the likelihood of mutation detection in MLH1/MSH2 in HNPCC families depending on the clinical criteria used; The Amsterdam I criteria have the highest predictive value for the identification of a mutation in MLH1 and MSH2 genes (40-60% likelihood of mutation detection), but this is met only in larger families.²² The likelihood of finding a mutation fell to 18% for the Amsterdam II criteria, and to 20-30% for the original Bethesda guidelines. Interestingly

there was a 28% chance of identifying a germline mutation in MLH1/MSH2 in an individual who developed CRC less than 30 years.

Syngal *et al* calculated similar sensitivity of the Amsterdam criteria for detecting a germline mutation in MLH1/MSH2; 61% with a specificity of 67%. Higher sensitivities are however reported for Amsterdam II and the Bethesda criteria; 78% and 94% respectively.²³

No perfect criteria exist for the diagnosis of HNPCC or indeed for predicting the likelihood of a MMR gene mutation, and difficulty arises in trying to obtain an adequate balance between sensitivity and specificity.

CANCER RISK ASSOCIATED WITH HNPCC

The lifetime risk of any cancer to mutation carriers in HNPCC is 91% for males, and 69% for females, with a 74% and 30% risk by age 70 for colorectal cancer respectively in each sex. The risk of ovarian cancer in females (*figure 1*) is around 10% by age 70 years,²⁴ and endometrial cancer around 40% by age 70 years (*figure 2*). MSH6 is associated with a slightly different tumour phenotype (later age of disease onset and lower incidence of CRC),¹¹ and an estimated lifetime cancer risk of 60%.²⁵ Presentation may be with only endometrial cancer in families and we have ascertained some cases through gynaecology clinics.

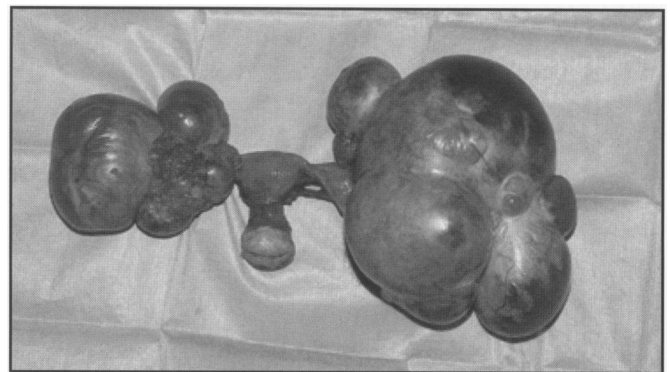

Fig 1. Ovarian cancer.

GENETIC COUNSELLING

Guidelines exist for segregating colon cancer risk into high (greater than 1 in 10), medium (less than 1 in 10 to 1 in 20), and low risk (less than 1 in 20 – ~1 in 50 (the population level) – *see table 1*). Most cancer genetic screening programs offer a “triage” system of referrals where patients fill in a detailed questionnaire to allow accurate confirmation of cancers in the family and the drawing of an accurate family tree. This enables the genetic team of clinical

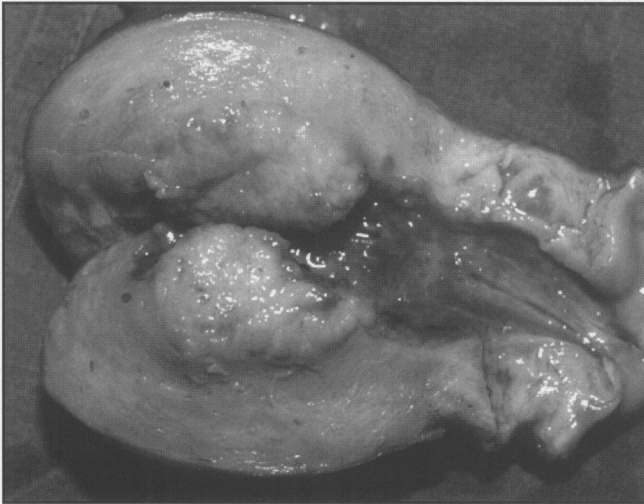

Fig 2. Endometrial cancer.

geneticist and genetic counsellors or genetic associates to work out an accurate individual risk for the proband.

Confirmation of cancers is important for two reasons. Firstly some patients may not know the exact cancers their relatives suffered from, or whether the cancer from which they died was primary or secondary. This is particularly important in patients with ovarian and colon cancers when it is important to distinguish which is the primary and which is the secondary cancer or if there are indeed two separate primaries (*figure 3*), as the risk to relatives will vary depending on the number of cancers in the family as to and whether the family fits medium or high risk screening criteria. Secondly some suspected cancers may actually be benign (e.g. ovarian cysts or endometrial fibroids), and the risk to the family may be very low.

Rarely, some patients may fabricate a family history, as they may be suffering from other problems of a nonphysical nature, or to seek attention, and these patients require special help in dealing with their problems. We have had some cases in our own practice, and GP's and surgeons should be aware of the possibility that this may occur, even if it is uncommon.

If patients are in the low risk category after preliminary risk estimation, management is usually by telephone and written contact to the patient with copies to the general practitioner, detailing that the patient is at low risk and giving reassurance and an offer of further risk evaluation if the family history changes (e.g. another relative becomes affected). Patients often find this very helpful, especially as they do not need to attend a hospital clinic. Medium risk patients are offered screening at an appropriate



Fig 3. Ovarian cancer with resection of colorectal tumour.

secondary level clinic with colonoscopy at defined intervals. Often this will be an 'entry' and 'exit' regime with initial colonoscopy at ~35 years and later colonoscopy at 50-55 years. This covers the main time that polyps will grow in the colon and allows prevention. High-risk patients are offered a consultation with a geneticist for consideration of genetic testing and a range of screening and preventative measures including colonoscopy at 2 yearly intervals from 25, or 5 years younger than the earliest affected case in the family (whichever comes first), up to age 75 years.

Surveillance programmes in the UK are based upon a study carried out by a group at Leiden University, Netherlands, who looked at 114 families with an identified mismatch repair gene defect and/or met the clinical criteria for HNPCC, and looked at the interval between surveillance and colorectal cancer.²⁶ They recommend colonoscopy with an interval of not more than two years for HNPCC families.

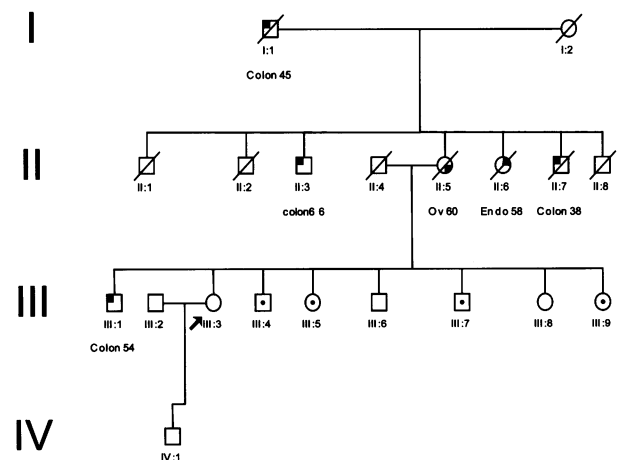

Fig 4. Pedigree showing typical referral for HNPCC.

TABLE I
Colorectal Cancer risks (population risk = 1 in 50)

<i>Family History of Colorectal Cancer</i>	<i>Lifetime Risks</i>	<i>Low Risk –</i>	<i>Medium Risk</i>	<i>High Risk</i>
1 RELATIVE >45 yrs <45 yrs	1 in 17 1 in 10	Yes	Yes	
2 RELATIVES one 1st degree and one 2nd degree two 1st degree relatives ave <60 two 1st degree relatives ave >70	1 in 12 1 in 6 1 in 10	Yes Yes	Yes	
3 OR MORE RELATIVES dominant pedigree or Amsterdam criteria HNPCC family	1 in 2 - 1 in 3			Yes

Discussion of the ovarian cancer risk (population risk 1 in 70 increasing to around 10-15% in cases of HNPCC) and endometrial cancer risk (population risk 1 in 75 increasing to around 30-40% in cases of HNPCC, and may be higher in MSH6 genetic mutations) is important in females with a history of HNPCC. Ovarian and uterine ultrasound with pipelle biopsy and CA125 tumour markers provide some reassurance although clinical trials are underway to determine the efficacy of this screening. Preventative oophorectomy/hysterectomy, and other surgical options are also discussed. Upper GI endoscopy needs to be considered if there is a history of stomach cancer in the family.

The family tree (*figure 4*) is a typical referral with the index case, III.3 (arrowed), being referred because of her family history which includes brother, III.1, with colon cancer at age 54, mother with ovarian cancer age 60, two maternal uncles with colon cancer (II.3 age 66 and II.7 age 38) and a maternal aunt with endometrial cancer aged 58. The family fit the Amsterdam criteria with 3 affected cases of HNPCC related cancer (CRC, endometrial cancer etc.), at least one (here 2 cases) with colon cancer under 50 and 2 generations being affected. Genetic testing of

the index case's, brother III.1, confirmed a mutation in the MSH2 gene consistent with HNPCC. Carrier testing was then offered to all family members and the index patient was shown not to carry the mutation although four of her siblings (dot indicates carrier) were found to be carriers of the mutation. This is powerful genetic information as the risk to the index case is reduced to the population risk of 1 in 50 (for CRC), and no additional screening is necessary for either her or her children (she cannot pass on a gene mutation she does not have). Her siblings, who are carriers, should have 2 yearly colonoscopies from 25 years and her two carrier sisters should also have endometrial and ovarian screening starting in their mid thirties.

Following genetic testing, if a mutation is found in a HNPCC family, other at risk family members should be offered testing as in the example above. If they prove to be negative for the family mutation, then further surveillance is not necessary, but it is important that they should be reminded that a background population risk for colorectal cancer still exists and lifestyle measures including a diet including fruit and vegetables and exercise may be helpful. Other issues including insurance risks can

be covered although this is less of a problem in the United Kingdom as there is a moratorium on the use of genetic tests,²⁷ which was extended in March 2005 from 5 to 10 years in a concordat between the insurance industry and the government and will be reviewed in 2008 before the 10 year moratorium ends in November 2011.²⁸

Families in which a mutation is not identified need to continue with ongoing surveillance until future genetic testing eventually allows clarification of the risks in the family with new genes being tested for as they are found.

CONCLUSIONS

The diagnosis of HNPCC allows early detection and prevention of HNPCC related cancers. Criteria exist to aid diagnosis for HNPCC and also to aid in selection of patients for molecular analysis of mismatch repair genes, although such testing is expensive and labour intense. Other candidate genes may be involved and may account for families with a phenotype not consistent with the Amsterdam criteria, and the current criteria may fail to diagnose families with MSH6 or other rare mutations.

HNPCC is an important condition relevant to the practice of medical practitioners from various specialties, particularly those who see and treat cancer patients. The condition is complex and all potential patients should be referred to a regional clinical genetics department where full assessment and counselling of the proband (and later the entire family) can be carried out, and screening programmes instigated through onward referral to colonoscopy services, or reassurance can be given in low risk cases.

ACKNOWLEDGEMENTS

LJD is funded by a Samaritan hospital fellowship and a research grant from Action Cancer.

REFERENCES

- Office for National Statistics. *Health Statistics Quarterly* 6. London: Office for National Statistics, Summer 2000. Available from: www.statistics.gov.uk
- Northern Ireland Cancer Registry. *Cancer incidence data 1993-6 and mortality data 1993-8*. Belfast: Northern Ireland Cancer Registry 1999.
- Allum WH, Slaney G, McConkey CC, Powell J. Cancer of the colon and rectum in the West Midlands 1957-1981. *Br J Surg* 1994; 81(7): 1060-3.
- Warthin AS, Hereditary with reference to carcinoma. *Arch Intern Med* 1913; 12: 546-55.
- Lynch HT, Krush AJ. Cancer family "G" revisited: 1895-1970. *Cancer* 1971; 27(6): 1505-11.
- Nystrom-Lahti M, Wu Y, Moisio AL, Hofstra RMW, Osinga J, Mecklin JP, *et al*. DNA mismatch repair gene mutations in 55 kindreds with verified or putative hereditary non-polyposis colorectal cancer. *Hum Mol Gen* 1996; 5(6): 763-9.
- Syngal S, Fox EA, Li C, Dovidio M, Eng C, Kolodner RD, *et al*. Interpretation of genetic test results for hereditary nonpolyposis colorectal cancer. *JAMA* 1999; 282(3): 247-53.
- Winjen J, Khan PM, Vasen H, van der Klift H, Mulder A, van Leeuwen-Cornelisse I, *et al*. Hereditary nonpolyposis colorectal cancer families not complying with the Amsterdam criteria show extremely low frequency of mismatch-repair-gene mutations. *Am J Hum Genet* 1997; 61(2): 329-35.
- Dunlop MG, Farrington SM, Nicholl I, Aaltonen L, Petersen G, Porteous M, *et al*. Population carrier frequency of hMSH2 and hMLH1 mutations. *Br J Cancer* 2000; 83(12): 1643-5.
- Gille JJ, Hogervorst FB, Pals G, Wijnen JT, van Schooten RJ, Dommering CJ, *et al*. Genomic deletions of MSH2 and MLH1 in colorectal cancer families detected by a novel-mutation detection approach. *Br J Cancer* 2002; 87(8): 892-7.
- Plaschke J, Engel C, Kruger S, Holinski-Feder E, Pagenstecher C, Mangold E, *et al*. Lower incidence of colorectal cancer and later age of disease onset in 27 families with MLH1 or MSH2 mutations: the German Hereditary Nonpolyposis Colorectal Cancer Consortium. *J Clin Oncol* 2004; 22(22): 4486-94.
- Nicolaides NC, Papadopoulos N, Liu B, Wei YF, Carter KC, Ruben SM, *et al*. Mutations of two PMS homologues in hereditary nonpolyposis colon cancer. *Nature* 1994; 371(6492): 75-80.
- Liu T, Yan H, Kuismanen S, Percesepe A, Bisgaard ML, Pedroni M, *et al*. The role of hPMS1 and hPMS2 in predisposing to colorectal cancer. *Cancer Res* 2001; 61(21): 7798-7802.
- Vasen HF, Mecklin JP, Khan PM, Lynch HT. The International Collaborative Group on Hereditary Non-Polyposis Colorectal Cancer (ICG-HNPCC). *Dis Colon Rectum* 1991; 34(5): 424-5.
- Vasen HF, Watson P, Mecklin JP, Lynch HT. New clinical criteria for hereditary nonpolyposis colorectal cancer (HNPCC, Lynch syndrome) proposed by the International Collaborative Group on HNPCC. *Gastroenterology* 1999; 116(6): 1453-6.
- Boland CR, Thibodeau SN, Hamilton SR, Sidransky D, Eshleman JR, Burt RW, *et al*. A National Cancer Institute Workshop on Microsatellite Instability for cancer detection and familial predisposition: development of international criteria for the determination of microsatellite instability in colorectal cancer. *Cancer Res* 1998; 58(22): 5248-57.

17. Rodriguez-Bigas MA, Boland CR, Hamilton SR, Henson DE, Jass JR, Khan PM, *et al.* A National Cancer Institute Workshop on Hereditary Nonpolyposis Colorectal Cancer Syndrome: meeting highlights and Bethesda guidelines. *J Natl Cancer Inst* 1997; 89(23): 1758-62.
18. Umar A, Boland R, Terdiman JP, Syngal S, de la Chapelle A, Ruschoff J, *et al.* Revised Bethesda Guidelines for hereditary nonpolyposis colorectal cancer (Lynch syndrome) and microsatellite instability. *J Natl Cancer Inst* 2004; 96(4): 261-8.
19. Shia J, Klimstra DS, Nafa K, Offit K, Guillem J, Markowitz AJ, *et al.* Value of immunohistochemical detection of DNA mismatch repair proteins in predicting germline mutation in hereditary colorectal neoplasms. *Am J Surg Pathol* 2005; 29(1): 96-104.
20. Vasen HF, Hendricks Y, de Jong AE, van Puijenbroek M, Tops C, Brocker-Vriends AH, *et al.* Identification of HNPCC by molecular analysis of colorectal and endometrial tumours. *Dis Markers* 2004; 20(4-5): 207-13.
21. Wu Y, Berends MJ, Mensink RG, Kempinga C, Sijmons RH, van Der Zee AG, *et al.* Association of hereditary non-polyposis colorectal cancer-related tumours displaying low microsatellite instability with MSH6 germline mutations. *Am J Hum Genet* 1999; 65(5): 1291-8.
22. Grady WM. Genetic testing for high risk colon cancer patients. *Gastroenterology* 2003; 124(6): 1574-94.
23. Syngal S, Fox EA, Eng C, Kolodner RD, Garber JE. Sensitivity and specificity of clinical criteria for hereditary non-polyposis colorectal cancer associated mutations in MSH2 and MLH1. *J Med Genet* 2000; 37(9): 641-5.
24. Dunlop MG, Farrington SM, Carothers AD, Wyllie AH, Sharp L, Burn J, *et al.* Cancer risk associated with germline DNA mismatch repair gene mutations. *Hum Mol Genet* 1997; 6(1): 105-10.
25. Buttin BM, Powell MA, Mutch DG, Rader JS, Herzog TJ, Gibb RK. Penetrance and expressivity of MSH6 germline mutations in seven kindreds not ascertained by family history. *Am J Hum Genet* 2004; 74(6): 1262-9 Epub 2004.
26. De Vos Tot Nederveen, Cappel WH, Nagengast FM, Griffioen G, Menko FH, Taal BG, Kleibeuker JH, *et al.* Surveillance for hereditary nonpolyposis colorectal cancer: a term study on 114 families. *Dis Colon Rectum* 2002; 45(12): 1588-94.
27. Morrison PJ. Insurance, genetic testing and familial cancer: recent policy changes in the United Kingdom. *Ulster Med J* 2001; 70(2): 79-88.
28. Department of Health. Association of British Insurers. Concordat and moratorium on genetics and insurance. Department of Health, London, March 2005. Available from: www.dh.gov.uk/assetRoot/04/10/60/50/04106050.pdf