

# Lidocaine Block of Cardiac Sodium Channels

BRUCE P. BEAN, CHARLES J. COHEN, and RICHARD W. TSIEN

From the Department of Physiology, Yale University School of Medicine,  
New Haven, Connecticut 06510

**ABSTRACT** Lidocaine block of cardiac sodium channels was studied in voltage-clamped rabbit Purkinje fibers at drug concentrations ranging from 1 mM down to effective antiarrhythmic doses (5–20  $\mu\text{M}$ ). Dose-response curves indicated that lidocaine blocks the channel by binding one-to-one, with a voltage-dependent  $K_d$ . The half-blocking concentration varied from  $>300 \mu\text{M}$ , at a negative holding potential where inactivation was completely removed, to  $\sim 10 \mu\text{M}$ , at a depolarized holding potential where inactivation was nearly complete. Lidocaine block showed prominent use dependence with trains of depolarizing pulses from a negative holding potential. During the interval between pulses, repriming of  $I_{\text{Na}}$  displayed two exponential components, a normally recovering component ( $\tau < 0.2 \text{ s}$ ), and a lidocaine-induced, slowly recovering fraction ( $\tau \sim 1\text{--}2 \text{ s}$  at pH 7.0). Raising the lidocaine concentration magnified the slowly recovering fraction without changing its time course; after a long depolarization, this fraction was one-half at  $\sim 10 \mu\text{M}$  lidocaine, just as expected if it corresponded to drug-bound, inactivated channels. At  $\leq 20 \mu\text{M}$  lidocaine, the slowly recovering fraction grew exponentially to a steady level as the preceding depolarization was prolonged; the time course was the same for strong or weak depolarizations, that is, with or without significant activation of  $I_{\text{Na}}$ . This argues that use dependence at therapeutic levels reflects block of inactivated channels, rather than block of open channels. Overall, these results provide direct evidence for the “modulated-receptor hypothesis” of Hille (1977) and Hondeghem and Katzung (1977). Unlike tetrodotoxin, lidocaine shows similar interactions with Na channels of heart, nerve, and skeletal muscle.

## INTRODUCTION

Lidocaine is effective as an antiarrhythmic agent in the heart over a concentration range of 5–20  $\mu\text{M}$  (Gianelly et al., 1967; Jewitt et al., 1968; Bellet et al., 1971). Unlike its local anesthetic effect on nerve, which clearly involves block of Na channels at much higher ( $>100 \mu\text{M}$ ) drug concentrations (Schmidtmayer and Ulbricht, 1980; Courtney, 1981; see Hille, 1978), lidocaine’s antiarrhythmic action is not completely understood (see Rosen, 1979; Gettes, 1981). Indeed, there has been controversy about the importance of

Address reprint requests to Dr. Richard W. Tsien, Dept. of Physiology, Yale University School of Medicine, 333 Cedar St., P.O. Box 3333, New Haven, CT 06510. Dr. Bean’s present address is Dept. of Physiology and Biophysics, University of Iowa, Iowa City, IA 52242. Dr. Cohen’s present address is Miles Institute, P.O. Box 1956, New Haven, CT 06509.

sodium channel block as an antiarrhythmic mechanism (Arnsdorf, 1976; Hauswirth and Singh, 1979).

Until very recently, the interaction between antiarrhythmic drugs and cardiac sodium channels could be studied only indirectly, by recordings of maximal upstroke velocity ( $\dot{V}_{\max}$ ) of the action potential. The information gathered by  $\dot{V}_{\max}$  in heart has been paralleled, at least qualitatively, by later but more detailed voltage-clamp studies of local anesthetic block of sodium channels in nerve or skeletal muscle. Thus, in the various tissues, block is enhanced by steady membrane depolarization (Fan and Feng, 1951; Weidmann, 1955; Khodorov and Belyaev, 1967; Chen et al., 1975; Weld and Bigger, 1975; Hille, 1977) or by repetitive activity (Johnson and McKinnon, 1957; Heistracher, 1971; Strichartz, 1973; Courtney, 1975; Chen et al., 1975; Chen and Gettes, 1976), and recovery from block is slowed by the reduction of external pH (Khodorov et al., 1976; Hille, 1977; Schwarz et al., 1977; Grant et al., 1980). Since arrhythmias often involve cardiac tissue that is partially depolarized, rapidly firing, or acidotic, such modulatory effects could be relevant to the therapeutic actions of lidocaine and other agents (Hille, 1978; Gettes, 1981).

The phenomena of voltage- and use-dependent block have led to a modulated-receptor hypothesis (Hille, 1977; Hondeghem and Katzung, 1977) that interprets block by local anesthetic molecules in terms of a channel-associated receptor. Hydrophobic and hydrophilic drugs seem to reach this single receptor via different pathways (Hille, 1977). Binding rates and equilibria depend on the state of the channel; for example, lidocaine is thought to bind more tightly to open or inactivated channels than to resting channels. The pH dependence of local anesthetic block can also be accounted for within the framework of the hypothesis (Schwarz et al., 1977).

Further progress calls for direct recordings of sodium currents in heart.  $\dot{V}_{\max}$  can be a nonlinear measure of available sodium conductance and can give misleading information about the voltage and time dependence of drug block (Ulbricht and Wagner, 1975; I. S. Cohen and Strichartz, 1977; C. J. Cohen et al., 1981; I. S. Cohen et al., 1982; Bean et al., 1982). Sodium currents are readily measured under voltage clamp in nerve or skeletal muscle, but this information must be interpreted cautiously because sodium channels in these tissues clearly differ from those in heart in their response to tetrodotoxin or saxitoxin (Baer et al., 1976; C. J. Cohen et al., 1981; Rogart et al., 1982). Fortunately, new methods are now available for studying cardiac  $I_{\text{Na}}$  under voltage clamp, and direct studies of effects of lidocaine and other drugs have already begun (Lee et al., 1981; Bean et al., 1981; Colatsky, 1982; Sanchez-Chapula et al., 1982). Lee et al. (1981) described the effect of lidocaine on single rat ventricular cells and, surprisingly, found considerable tonic block and very little use-dependent block, in contrast to previous studies using  $\dot{V}_{\max}$  (Chen et al., 1975; Courtney, 1979a).

In this paper, we used the rabbit Purkinje fiber preparation (see Colatsky and Tsien, 1979a, b) to analyze lidocaine block of cardiac sodium channels under voltage clamp. Our goal was to test the modulated-receptor hypothesis in a quantitative way, by determining how strongly lidocaine binds to channels

in the resting, open, and inactivated states, and by answering several related questions: Is binding one-to-one? How much tonic block and use-dependent block can lidocaine produce over its therapeutic range? Does use dependence arise primarily from drug binding to open channels or binding to inactivated channels? How do membrane potential and pH affect the kinetics of block and unblock? How does lidocaine compare with tetrodotoxin in its interaction with the gating machinery? How similar are cardiac and nerve sodium channels with respect to lidocaine block? How does lidocaine block of sodium channels account for its antiarrhythmic action?

Some of this work has already been reported in preliminary form (Bean et al., 1981; Bean et al., 1982).

#### METHODS

Sodium currents were studied in short pieces of rabbit Purkinje fibers using a two-microelectrode voltage clamp (Colatsky and Tsien, 1979*b*; Colatsky, 1980). A fiber was considered acceptable only if the time constant for the decay of a capacity transient was  $<1.3$  ms and if the deviation in the voltage trace was  $<7$  mV for the largest sodium current. Colatsky and Tsien (1979*a*) and Colatsky (1980) have described experimental tests for the adequacy of voltage control in the preparation, and computer cable simulations of voltage-clamp experiments have shown that even in the worst case of acceptability, peak sodium current in the whole fiber is proportional to available sodium conductance to within an error of 3%.<sup>1</sup>

Solutions contained concentrations of NaCl and choline-Cl that totaled 150 mM, 4 mM KCl, 1.8 mM CaCl<sub>2</sub>, 0.5 mM MgCl<sub>2</sub>, 3.6 mM MnCl<sub>2</sub>, 5.0 mM dextrose, and 10 mM HEPES. NaOH or KOH was used to titrate the solutions to the desired pH. Temperature was maintained at  $17 \pm 1^\circ\text{C}$ . Lidocaine HCl was obtained from Astra Pharmaceutical Products, Inc. (Worcester, MA).

In most of the experimental protocols, it was necessary to establish a holding potential that was negative enough to ensure complete removal of inactivation. In experiments involving large concentrations of lidocaine, potentials in the range  $-115$  to  $-135$  mV were often required. To reduce the steady holding current needed for such hyperpolarizations, 10 mM CsCl was added to the bathing solution in most experiments. Addition of Cs greatly improved the chances of survival of hyperpolarized fibers; comparison of experiments with and without Cs showed no significant differences in equilibrium lidocaine block or in the kinetics of block.

Raw currents were corrected for capacitative current by subtraction of a scaled exponential fit to an experimental capacity transient (obtained for a small depolarization); this correction was usually  $<2\%$  at the time of peak  $I_{\text{Na}}$ . Leak current was corrected for by subtracting the steady-state current at the end of a 50-ms depolarization. After correction for leak and capacitative currents, peak  $I_{\text{Na}}$  was read using a polynomial fit to the digitized points in the region of the peak (Hille, 1971). Least-squares curve-fitting of data with theoretical curves was done using the Patternsearch algorithm (see Colquhoun, 1971).

#### RESULTS

##### *Use-dependent Block*

Fig. 1 shows the effect of lidocaine on sodium currents in a rabbit Purkinje

<sup>1</sup> Cohen, C. J., B. P. Bean, and R. W. Tsien. A comparison between  $\dot{V}_{\text{max}}$  and voltage-clamp sodium currents in cardiac Purkinje fibers. Manuscript in preparation.

fiber under two conditions: after a long resting period at a negative potential ( $-105$  mV), and then during a train of stimulating voltage-clamp pulses. The top three panels in Fig. 1 show, superimposed,  $I_{Na}$  during the 1st and 12th voltage-clamp pulses in a train of 500-ms pulses given at 1 Hz. In the absence of drug (left panel), the 1st and 12th currents are just about the same size. With  $20 \mu\text{M}$  lidocaine present (middle panel), the 1st pulse in the train elicits a current that is almost unchanged from the control. However, subsequent

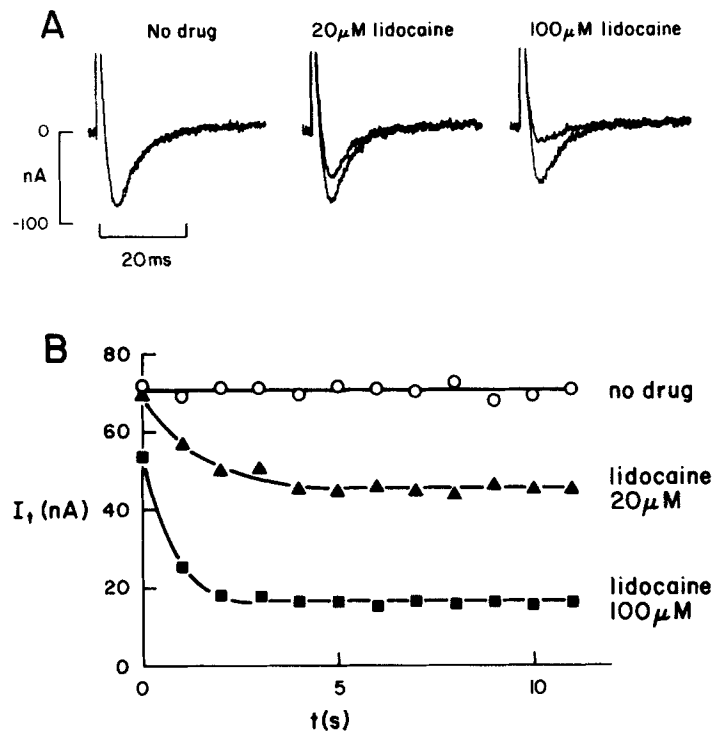

FIGURE 1. Use-dependent effect of lidocaine.  $I_{Na}$  was measured during trains of 500-ms pulses from  $-105$  to  $-35$  mV at 1.0 Hz. (A) The membrane currents were measured on the 1st and 12th pulses in (from left to right) 0, 20, and 100  $\mu\text{M}$  lidocaine. The rest period before each train was long enough for effects of previous trains to be removed. (B) Peak sodium current amplitudes were measured for each of the pulses. The decrease in current magnitude has been fitted by an exponential curve, with  $\tau = 1.3$  s in 20  $\mu\text{M}$  lidocaine and  $\tau = 0.7$  s in 100  $\mu\text{M}$  lidocaine. Preparation C74-3. 10 mM Na, pH 7.0, 17°C.

currents during the train become progressively smaller, and by the 12th pulse,  $I_{Na}$  is reduced to 63% of its size with no drug present. In 100  $\mu\text{M}$  lidocaine (right panel), the 1st pulse elicits a current reduced to 75% of control, and by the 12th pulse,  $I_{Na}$  is down to 22%. Fig. 1B shows the time course of the use-dependent effect during the trains of pulses. With the 500-ms pulses used in this experiment, the development of the use-dependent block during a train is quite rapid in both concentrations of lidocaine and is faster in 100  $\mu\text{M}$  lidocaine ( $\tau = 0.7$  s) than in 20  $\mu\text{M}$  lidocaine ( $\tau = 1.3$  s).

The most interesting aspect of Fig. 1 is that at 20  $\mu\text{M}$ , the high end of the spectrum of clinical concentrations, lidocaine has almost no effect on  $I_{\text{Na}}$  during the first depolarization after a resting period, while markedly reducing  $I_{\text{Na}}$  during stimulation at a moderate frequency. Moreover, the reduction of  $I_{\text{Na}}$  is apparent even during the second pulse of the train (Fig. 1B). Our results with lidocaine are different from those of Lee et al. (1981), who found very little use dependence in single rat ventricular cells. A possible reason for the difference is given in the Discussion.

#### *Effect on Sodium Channel Repriming*

The accumulation of use-dependent block during a train of pulses indicates that the interval between pulses is too short to allow complete recovery of sodium channel availability ("repriming"). Fig. 2 shows an experiment that was designed to determine directly how lidocaine affects sodium channel repriming. A long depolarization ("conditioning pulse") is followed by a return to the holding potential for a variable length of time and then by a second depolarization ("test pulse"), which assays the extent of repriming that occurred during the return to the holding potential. In the absence of lidocaine, the time course of repriming is fairly well fit by an exponential recovery curve with a time constant of 30 ms. In these rabbit Purkinje fibers there is very little slow inactivation, even after a 5-s depolarization, in contrast to typical nerve or skeletal muscle preparations. With 10  $\mu\text{M}$  lidocaine present, repriming occurs in two distinct phases: about half of the channels recover quickly, with approximately the same time course as in the absence of drug, but the other half of the recovery is much slower, with a time constant of  $\sim 2$  s. When the lidocaine concentration is increased to 200  $\mu\text{M}$  in the same fiber, almost all of the channels reprime in the slow phase, with a time constant similar to that in 10  $\mu\text{M}$ . The clear-cut separation between normal and slowly recovering phases strongly suggests that lidocaine binds to a specific receptor and only affects drug-bound channels; the time course is not compatible with a general effect on all the channels, as might be expected if lidocaine acted through some nonspecific effect on membrane structure.

Our interpretation of the lidocaine effect in Fig. 2 is based on the modulated-receptor hypothesis for local anesthetic block of sodium channels (Hille, 1977; Hondeghem and Katzung, 1977). Fig. 3A shows a particular version of the modulated-receptor model that is appropriate for interpreting the experiment in Fig. 2 and many of our other experiments. This scheme embodies a major feature of the modulated-receptor hypothesis, that channels in the inactivated state can bind drug with a different affinity from channels in the resting state, and also the additional hypothesis of Hille (1977) that both the neutral and charged forms of the drug can bind to the same channel-associated receptor, but that only the neutral form is able to interact directly with the channel in the resting or inactivated state. Once the neutral form has become bound, it can be protonated to form the bound, charged form. The scheme in Fig. 3A ignores interactions between lidocaine and the open state of the channel since these seem negligible for most of our experimental protocols, as discussed below. Fig. 3B shows an additional simplification that can be made when

drug binding is at equilibrium (as when a fiber has been held at the same potential for a long time in the presence of drug). States that differ only in the protonation of the drug molecule are lumped together; the unbound states are treated as though they interacted in a 1:1 manner with the total population of free drug molecules in either neutral or protonated form (D).

We return now to the repriming data in Fig. 2, interpreting the effect of lidocaine in terms of the model in Fig. 3A. In the model, after a long depolarization, channels are distributed between three states: I, IL, and  $ILH^+$ . When the membrane is repolarized, channels in state I reprime with the normal, fast time course, but those in states IL and  $ILH^+$  may reprime more slowly, since they must undergo several steps before returning to the resting

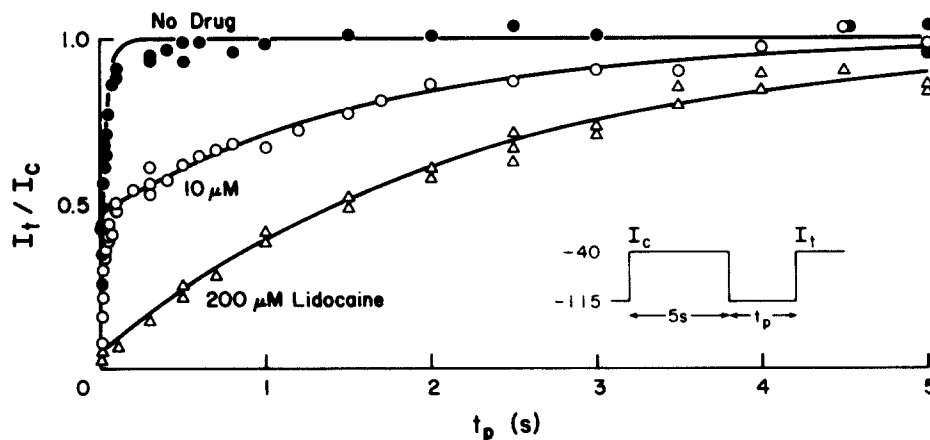

FIGURE 2. Slowing of sodium channel repriming by lidocaine. Solid curve through control points is drawn according to  $1 - \exp(-t/\tau)$ , with  $\tau = 30.1$  ms. Curves through the two sets of lidocaine points are drawn according to  $1 - A \exp(-t/\tau)$ ; for  $10 \mu\text{M}$ ,  $\tau = 1.70$  s, and  $A = 0.53$ ; for  $200 \mu\text{M}$ ,  $\tau = 2.26$  s and  $A = 0.95$ . These parameters were determined by a least-squares fit to points for  $t \geq 0.5$  s. In  $200 \mu\text{M}$  lidocaine,  $I_c$  was unchanged when the holding potential was changed to  $-125$  mV, which verifies that removal of inactivation was complete. Preparation C103-2. 6 mM Na, pH 7.0,  $16.5^\circ\text{C}$ .

state R. Thus, some channels reprime normally and some much more slowly, as is seen in the curve for  $10 \mu\text{M}$  lidocaine in Fig. 2. When the lidocaine concentration is increased, more of the channels are in the IL and  $ILH^+$  states and more of the repriming takes place in the slow phase, as is shown with  $200 \mu\text{M}$  lidocaine in Fig. 2. In the experimental data, the slow phase of repriming is well fitted by a single exponential; in the model, repriming entails redistribution between the six states in Fig. 3A, a kinetic process that is described by the sum of five exponential terms. However, in practice, when the model is applied by actually assigning numerical rate constants to fit the experimental data, one finds that the predicted slow repriming time course is virtually indistinguishable from a single exponential. The observed time course of the slow phase is thus consistent with the model. It is important to realize, though,

that the time constant is a complicated function of the many rate constants in the model and that there is no single rate-limiting step. Thus, the time constant cannot be used to derive individual rate constants in any simple way.

According to the model in Fig. 3, the partition of repriming into the fast and slow phases reflects the partition of inactivated channels between drug-free and drug-bound states. Thus, the strength of lidocaine binding to the inactivated state can be deduced from the relative fraction of channels in each phase of repriming. This distribution can be quantitated by fitting the slow phase with an exponential and extrapolating to time zero, as has been done in Fig. 2; this graphical procedure and its interpretation were introduced by Khodorov et al. (1976) in their analysis of local anesthetic block of frog nerve sodium channels. Even within the context of Fig. 3, the use of the  $y$  intercept

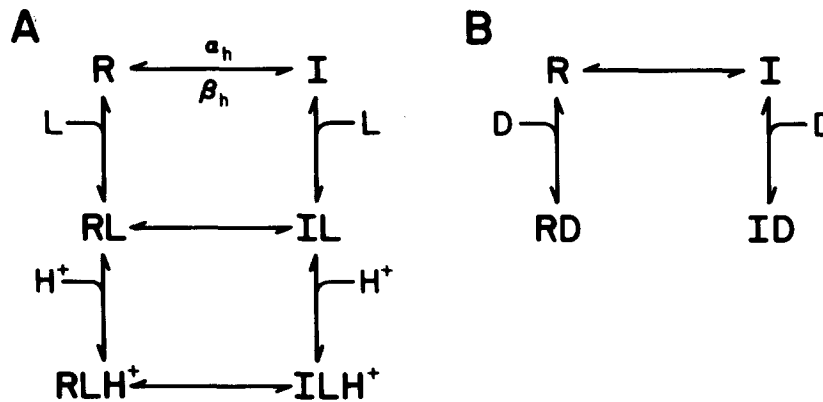

FIGURE 3. Modulated-receptor model for lidocaine binding. (A) Model for binding to resting and inactivated sodium channels, distinguishing between neutral and charged forms of the drug. R is the resting state; RL is the resting state with the neutral form of lidocaine bound; RLH<sup>+</sup> is with the charged form of lidocaine bound; I, IL, and ILH<sup>+</sup> are the corresponding forms of the inactivated state. (B) Equivalent model for equilibrium binding, with no distinction between drug forms.

as a measure of drug binding to the inactivated state is only approximate, but it is a convenient way of summarizing repriming data, and numerical simulations with the model suggest that the approximation is quite good.

Using the  $y$ -intercept method, does lidocaine binding to the inactivated state appear to be 1:1, as predicted by the modulated-receptor model? Fig. 4 shows collected results from application of a wide range of lidocaine concentrations to six different fibers. The collected data have been fit with a curve corresponding to 1:1 binding, with an apparent dissociation constant of 10  $\mu$ M. Although there is some scatter, the curve fits the data fairly well.

#### *Block at Depolarized Holding Potentials*

The  $y$ -intercept method of estimating binding to inactivated channels is indirect. Fig. 5 illustrates a much more direct approach. In this experiment,

the membrane was held at a relatively depolarized potential ( $-65$  mV), where almost all ( $\sim 99\%$ ) of the sodium channels were inactivated. Sodium current was elicited by infrequent test pulses to  $-45$  mV; although the current is due to only the 1% of the channels that are not inactivated, it was made large enough to measure easily by using a bathing solution with 155 mM Na instead of the usual 7–9 mM Na. Various concentrations of lidocaine were then applied and block was allowed to reach a steady state in each solution. The observed block arises almost entirely from drug binding to inactivated chan-

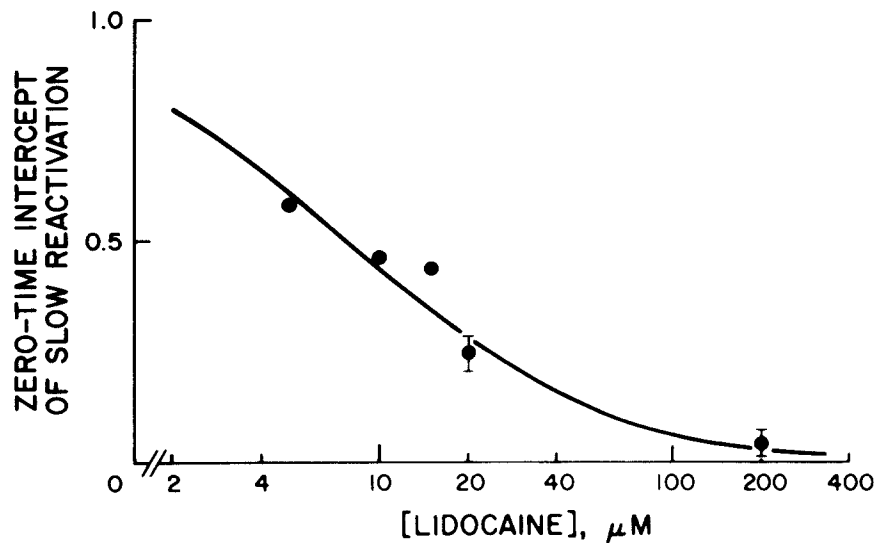

FIGURE 4. Zero-time intercept of slow repriming vs. [lidocaine]. Points for 5, 10, and 15  $\mu\text{M}$  were from a single fiber (the same as in Fig. 2). Data for 20  $\mu\text{M}$  and 200  $\mu\text{M}$ , plotted as means  $\pm$  SEM, are collected data from four and six experiments, respectively. In each experiment, the conditioning pulse was long enough (2–5 s) to produce a maximal effect and the holding potential was negative enough ( $-105$  to  $-135$  mV) to ensure complete removal of inactivation before the conditioning pulse: both conditions are necessary for a simple interpretation by the model in Fig. 3. Each zero-time intercept was obtained from a least-squares fit to the equation  $1 - A \exp(-t/\tau)$  to the slow component of repriming ( $t \geq 0.3$  s). The curve is a least-squares fit to  $[1 + [L]/K_D]^{-1}$  with  $K_D = 10 \mu\text{M}$ , 6.5–10 mM Na, pH 7.0, 16.5–17.5°C.

nels; such binding proportionately reduces the number of drug-free resting channels with which the inactivated channels are in rapid equilibrium.

The experiment shows that lidocaine is a very potent blocker when most channels are inactivated. The half-blocking dose was  $\sim 10 \mu\text{M}$ ; the solid line corresponds to a 1:1 binding curve with an apparent  $K_d$  of  $9.7 \mu\text{M}$ . It is striking that even  $5 \mu\text{M}$  lidocaine—a dose that is barely effective against arrhythmias—has a dramatic blocking effect. These results fit well with those in Fig. 4 in suggesting that lidocaine binds to inactivated channels with an apparent  $K_d$  of  $\sim 10 \mu\text{M}$ . Since the experiments in Fig. 4 were done in low-



sodium solutions and that in Fig. 5 was done in a full-sodium solution, it appears that lidocaine binding to the inactivated state is not much affected by external sodium.

#### *Block of Resting Channels*

How potently does lidocaine block channels in the resting state? Resting channel block can be measured simply and directly by applying lidocaine at

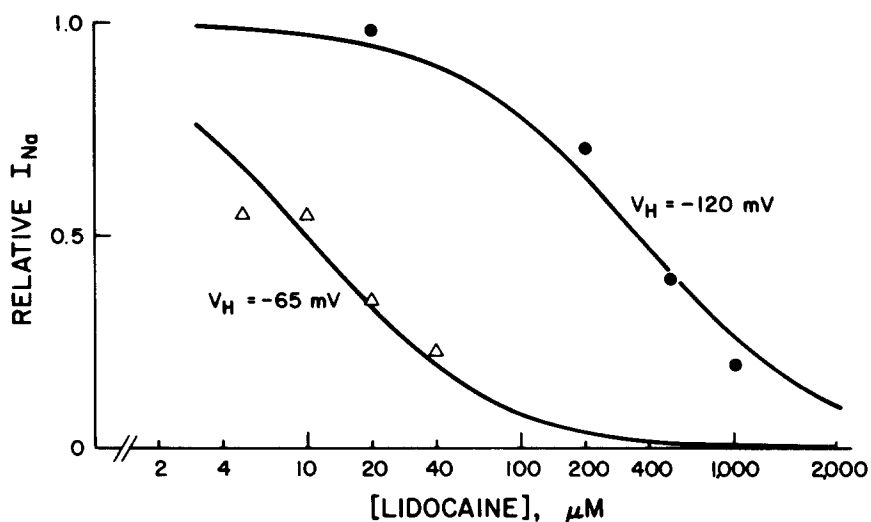

FIGURE 5. Dose-response for block at holding potentials of  $-120$  and  $-65$  mV. Filled circles: block at  $-120$  mV.  $I_{\text{Na}}$  was measured using test pulses to  $-40$  mV. Sequence of solutions and actual peak currents: control, 23.3 nA;  $400 \mu\text{M}$  lidocaine for 11 min, 10.0 nA; 1 mM lidocaine for 8 min, 5.4 nA; washout for 10 min, 29.1 nA;  $200 \mu\text{M}$  lidocaine for 10 min, 20.5 nA; washout for 14 min, 29.4 nA;  $20 \mu\text{M}$  lidocaine for 12 min, 28.8 nA. Hyperpolarizing to  $-131$  mV did not increase the current size, even in 1 mM lidocaine. Preparation C95-3. 8.5 Na, pH 7.0,  $17.5^\circ\text{C}$ . Triangles: block at  $-65$  mV. Test pulses to  $-45$  mV. Sequence of solutions and actual peak currents: control, 94 nA;  $10 \mu\text{M}$  lidocaine for 5.5 min, 54 nA;  $20 \mu\text{M}$  lidocaine for 6 min, 35 nA; washout for 8.5 min, 107 nA;  $5 \mu\text{M}$  lidocaine for 12 min, 61 nA;  $40 \mu\text{M}$  lidocaine for 9 min, 27 nA; washout for 6 min, 119 nA. Preparation C92-1. 155 mM Na, pH 7.0,  $17.0^\circ\text{C}$ . For both experiments, each solution was applied long enough for  $I_{\text{Na}}$  to reach a steady state. The fiber was rested for at least 15 s before each test pulse. In both experiments, currents were normalized assuming a linear drift of peak  $I_{\text{Na}}$  in the control solution.

a very negative holding potential, where virtually all channels are in the resting state, and by using infrequent pulses to assay sodium current, in order to avoid extra use-dependent block. The data presented in Fig. 1 already suggest that drug binding to the resting state is weak, since  $20 \mu\text{M}$  lidocaine had no effect on the current during the first pulse in the train, and  $100 \mu\text{M}$  lidocaine reduced the current by only  $\sim 20\%$ .

Fig. 5 shows the results of an experiment that determined, in a single preparation, a dose-response curve for block of sodium currents elicited with infrequent pulses (1/min) from a holding potential of  $-120$  mV. A 1:1 binding curve with a half-blocking concentration of  $353 \mu\text{M}$  provides a good fit to the data, probably well within experimental error. When collected dose-response data from eight fibers were fit (not shown), the value of the effective dissociation constant when inactivation was completely removed was  $441 \mu\text{M}$ , and again the assumption of 1:1 binding agreed well with the data.

#### *Shift of the Steady-State Availability Curve*

The results presented so far show that lidocaine binds much more tightly to the inactivated state of the channel (apparent  $K_d \sim 10 \mu\text{M}$ ) than to the resting state (apparent  $K_d > 300 \mu\text{M}$ ). According to the principle of microscopic reversibility, tighter binding of a drug to the inactivated state must be accompanied by a shift in equilibrium from resting toward inactivated states once channels have bound drug (see Hille, 1978). The shift in the distribution cannot be measured directly, since the drug-bound channels are assumed to be electrically silent, but the change in the overall availability of sodium channels as a function of membrane potential can be measured. Experiments in nerve and skeletal muscle have shown such shifts to exist, but the magnitude of the shifts has not been measured accurately for lidocaine under steady-state conditions.

Fig. 6 shows the shift of the availability curve by  $40 \mu\text{M}$  lidocaine. Both curves were determined using holding potentials that were established for long enough before the test pulse to ensure a steady state ( $>5$  s for the control,  $>10$  s for lidocaine). The solid curve through the control points is the best fit to a conventional inactivation curve expression (Hodgkin and Huxley, 1952). The solid curve through the lidocaine points is a similar curve with a smaller maximum current, a midpoint shifted in the hyperpolarizing direction, and with the same steepness factor as in the control—the changes that are expected if there is weak 1:1 binding to the resting state and strong 1:1 binding to the inactivated state (Fig. 6B). Lidocaine-induced changes in steady-state availability curves were determined in different fibers for various lidocaine concentrations (Table I); the shift in midpoint was larger for larger concentrations of lidocaine, and there was no consistent change in the steepness of the curves.

It is interesting to ask whether the shift in midpoint as a function of lidocaine concentration can be predicted by the estimates already made for lidocaine's affinity for the resting and inactivated states. Fig. 7 compares the observed shifts with a solid curve derived from the model in Fig. 3B with apparent  $K_d$ 's of  $10 \mu\text{M}$  for binding to the inactivated state and of  $440 \mu\text{M}$  for binding to the resting state. Overall, the correspondence between prediction and experiment seems quite good, especially in light of the known oversimplifications of the model (see Discussion).

#### *Voltage Dependence of Repriming*

So far, we have examined lidocaine block under various steady-state conditions and have found that the modulated-receptor model in Fig. 3 is quite satisfac-

tory for understanding the results. We turn now to considering the kinetics with which lidocaine binds and unbinds and the gating kinetics of lidocaine-bound channels. Consider, for example, the slow phase of repriming that occurs in the presence of lidocaine. This phase of repriming is due to a movement of channels from the IL and ILH<sup>+</sup> states to the R state, but what is the pathway of recovery? Do IL channels return by IL→RL→R or by IL→I→R? In other words, must channels first unbind lidocaine before they can recover from inactivation?

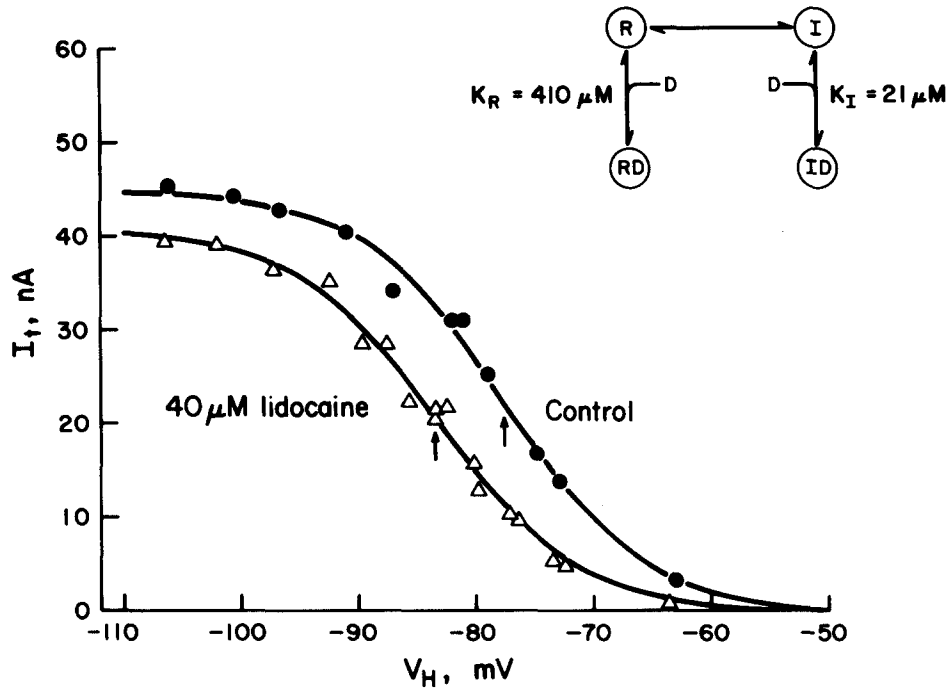

FIGURE 6. Effect of lidocaine on the voltage dependence of  $I_{Na}$  availability. The peak test pulse current was plotted vs. the holding potential, which was established for long enough to reach steady state ( $>5$  s for control,  $>10$  s with lidocaine). Solid lines are drawn according to  $I_{max}/(1 + \exp[V - V_h/k])$ . For the control,  $I_{max} = 44.8$  nA,  $V_h = -77.7$  mV,  $k = 5.99$ . With lidocaine,  $I_{max} = 40.8$  nA,  $V_h = -83.5$  mV,  $k = 5.99$ . Arrows indicate midpoints. Inset: modulated-receptor model that accounts for the effect of lidocaine on  $I_{Na}$  availability. Preparation C71-3. 9 Na, pH 7.35, 17.0°C.

An experimental approach to this question is to examine the dependence on membrane potential of the slow phase of repriming. If, for the sake of argument, channels must unbind lidocaine before repriming, and if unbinding is rate limiting, one might expect that the time course of the slow phase would depend only slightly on membrane potential. Previous work on this question has led to contradictory conclusions. Khodorov and his collaborators (1976) fit the onset and recovery of the "slow inactivation" in nerve caused by

procaine and trimecaine binding by a model that assumed that channels had to first unbind drug before recovering from inactivation. Their model would predict little voltage dependence of the repriming time course at potentials where removal of inactivation is complete; however, they had no experimental test of this prediction. On the other hand,  $\dot{V}_{\max}$  experiments in heart have shown a substantial voltage dependence of the lidocaine-induced phase of repriming (Chen et al., 1975; Oshita et al., 1980; Grant et al., 1980). The indirectness of  $\dot{V}_{\max}$  measurements makes this observation difficult to interpret, though; such an apparent voltage dependence could, in principle, arise merely from a nonlinear relationship between  $\dot{V}_{\max}$  and available sodium conductance.

TABLE I  
LIDOCAINE-INDUCED SHIFTS OF  $I_{Na}$  AVAILABILITY

Experiment	[Lidocaine] $\mu M$	[Na] <sub>o</sub> $mM$	$I_{\max}$ $nA$	$k$ $mV$	$V_h$ $mV$	$\Delta V_h$ $mV$
C102-1	0	8	33.3	5.22	-95.3	-4.8
	20	8	36.3	5.74	-100.1	
C71-3	0	9	44.8	5.99	-77.7	-5.5
	40	9	39.6	5.28	-83.2	
C83-1	0	4	14.2	3.16	-87.5	-11.5
	40	4	14.4	4.97	-92.5	
	200	4	14.0	5.48	-99.0	
C95-3	0	8.5	28.4	6.04	-90.8	-10.0
	200	8.5	20.9	5.35	-100.8	
C103-2	0	6	32.8	3.72	-90.6	-22.0
	1,000	8	28.9	5.79	-115.6	
	0	5	18.5	4.73	-96.7	

The dependence of test pulse  $I_{Na}$  on holding potential was fit by  $I_{\max}/(1 + \exp[(V_H - V_h]/k))$  using a least-squares method that allowed  $I_{\max}$ ,  $V_h$ , and  $k$  all to vary. Holding potentials were established long enough (>2 s without lidocaine, >8 s with lidocaine) to reach a steady state. Experiments were at pH 7.0, except C71-3, which was at pH 7.4.

Fig. 8 shows the voltage dependence of the slow phase of repriming produced by lidocaine. The time course of repriming was examined over a membrane potential range where repriming in the absence of drug was strongly voltage dependent, changing from a time constant of 81 ms at -105 mV to 15 ms at -135 mV. In the presence of 200  $\mu M$  lidocaine, after a long depolarization, almost all of the repriming occurs in the slow phase. Although repriming in the presence of lidocaine is >20 times slower than in the absence of drug, it is still strikingly voltage dependent; the time constant of the slow phase decreases from 1.5 s at -105 mV to 0.44 s at -135 mV. In another experiment with 200  $\mu M$  lidocaine (Table II), repriming in the presence of

lidocaine was also clearly voltage dependent. In a third experiment, with 40  $\mu\text{M}$  lidocaine, there was little voltage dependence of the exponentials fitted to the slow phase, but in this experiment, the amplitude of the slow phase was unusually small and there was probably considerable error in making the fits. Overall, the degree of voltage dependence that remains even at large lidocaine concentrations suggests that at least some channels recover from inactivation without first unbinding lidocaine. Kinetic simulations using the model in Fig. 3A confirmed that the observed voltage dependence is much more than can be accounted for on the assumption that channels must unbind drug before recovering from inactivation.

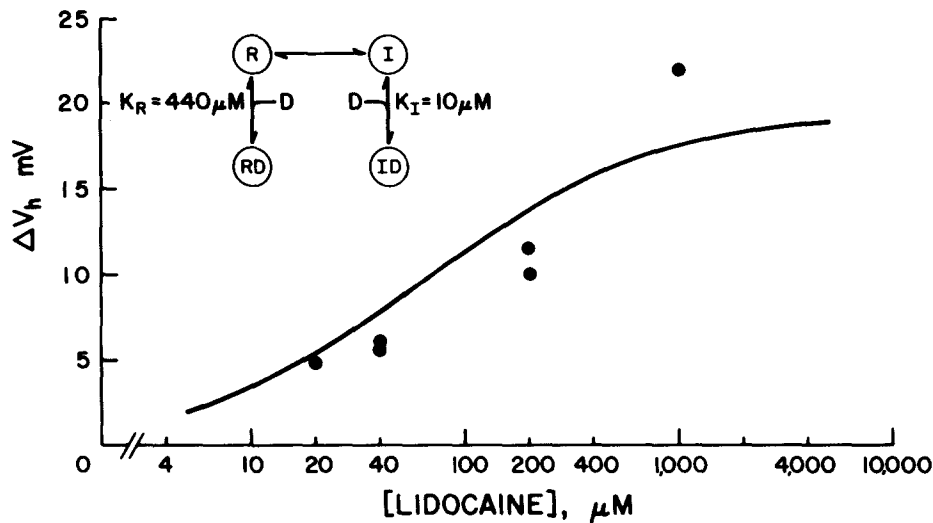

FIGURE 7. Shift in midpoint of availability curve vs. [lidocaine]. Solid curve: shifts expected from modulated-receptor model (inset). Curve is drawn according to  $\Delta V_h = k \ln[(1 + [L]/K_R)/(1 + [L]/K_I)]$ , where  $k$  is the slope factor of the inactivation curve,  $L$  is the lidocaine concentration, and  $K_R$  and  $K_I$  are the apparent dissociation constants for the resting and inactivated states.  $k$  is taken as 5.1 mV (the mean of the  $k$ 's in Table I),  $K_R$  as 440  $\mu\text{M}$ , and  $K_I$  as 10  $\mu\text{M}$ . Note that  $(\Delta V_h)_{[L] \rightarrow \infty} = k \ln(K_I/K_R) = -19.3$  mV, in fair agreement with the  $-30$ -mV voltage shift assumed for inactivated channels by Hondeghem and Katzung (1977).

#### *Is Use-dependent Block Caused by Block of Open Channels?*

The results in Fig. 1 showed that when a train of voltage-clamp pulses is given at a moderate frequency, extra block develops during the train over and above any tonic block that is present with infrequent pulses. When one considers the extra block that develops during one of the voltage pulses in the train, an interesting question is whether most of the extra block develops early in the depolarization, when the available sodium channels are opening and then inactivating (a process that is complete within 10–20 ms), or later in the depolarization, after the channels have become inactivated. That is, is the

extra block caused primarily by lidocaine binding to open channels or to inactivated channels? We have already referred to the examination of sodium current kinetics as one test for open-channel block.

Fig. 9 shows results from an experiment that tested this point using a different approach. A conditioning depolarization was given for various

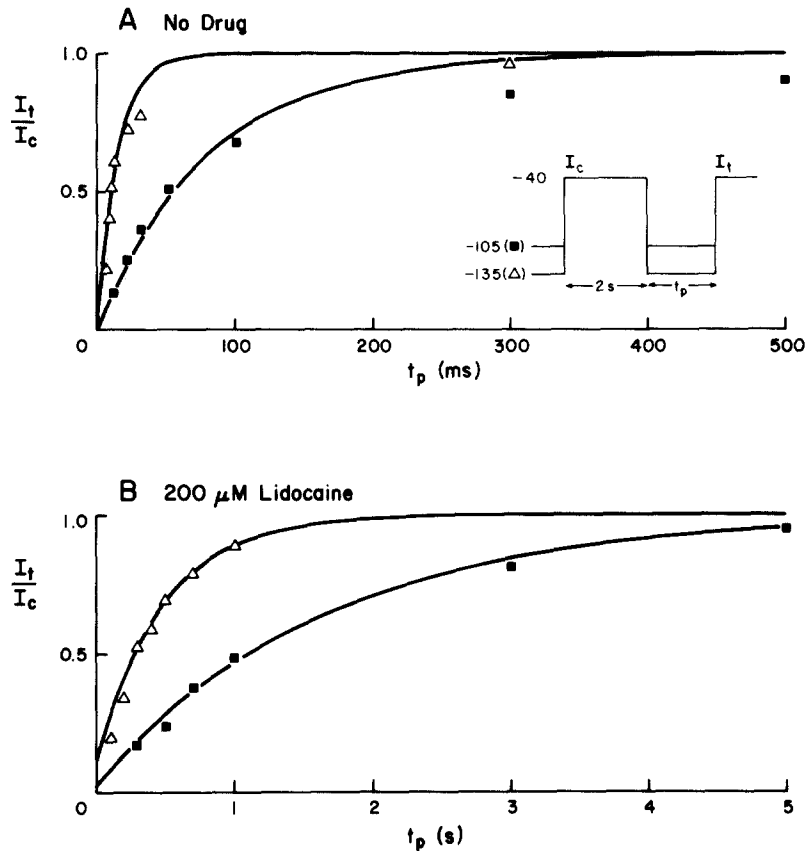

FIGURE 8. Voltage dependence of repriming with and without lidocaine. (A) No drug. Solid curves are  $1 - \exp(-t/\tau)$ , with  $\tau = 81$  ms at  $-105$  mV and  $\tau = 15$  ms at  $-135$  mV. (B) Repriming in the presence of  $200 \mu\text{M}$  lidocaine (note change in time scale). Solid curves are  $1 - A \exp(-t/\tau)$ , with  $\tau = 1.7$  s,  $A = 0.98$  at  $-105$  mV;  $\tau = 0.48$  s,  $A = 0.90$  at  $-135$  mV. The data in A were obtained after washout of drug; deviation from single exponential may be due to incomplete washout. Preparation C95-3.  $8.5$  Na, pH  $7.0$ ,  $17.5^\circ\text{C}$ .

lengths of time, and after a 250-ms return to the holding potential, a test pulse of  $-49$  mV was given. Test pulse sodium current gives a measure of the extra block that developed during the conditioning pulse; the 250-ms return to rest is long enough so that lidocaine-free channels would have time to reprime almost completely. Fig. 9A shows results for  $20 \mu\text{M}$  lidocaine. The

time course of development of extra block is shown for two conditioning potentials,  $-69$  and  $+31$  mV. Both of these potentials are depolarized enough so that almost all of the channels inactivate during the conditioning pulse, but at  $-69$  mV there was no detectable sodium current, whereas at  $+31$  mV, sodium channel activation is maximal. Despite this difference, the development of extra block is very similar at the two potentials. In particular, there is not the large, sudden drop in test current for very short conditioning pulses to  $+31$  mV that would be expected if extra block were due mainly to binding to open channels. (At  $+31$  mV, opening and inactivation of the channels was complete in 10 ms; the first time point in Fig. 9A is for a 40-ms depolarization, and the test current had only declined to 0.9 of control.) Instead, extra block at  $+31$  mV, as at  $-69$  mV, develops with a smooth time course with a half-time of several hundred milliseconds, which is consistent with most or all of

TABLE II  
VOLTAGE DEPENDENCE OF REPRIMING WITH AND WITHOUT  
LIDOCAINE

Experiment	Potential	$\tau$ , no drug	$\tau$ , drug	[Lidocaine]
	<i>mV</i>	<i>s</i>	<i>s</i>	$\mu\text{M}$
C95-2	-94	0.058	1.00	200
	-115	0.023	0.51	
C95-3	-105	0.081	1.80	200
	-120	0.036	0.81	
	-135	0.015	0.48	
C72-3	-95	0.121	1.42	40
	-108	0.064	1.56	

The slow time constant of reactivation was determined by a least-squares fit to  $1 - A \exp(-t/\tau)$  using the points beyond the time ( $\geq 0.3$  s) that reactivation in the absence of drug was substantially ( $>95\%$ ) complete. Experiments C95-2 and C95-3 were at pH 7.0; experiment C72-3 was at pH 7.4.

the extra block being caused by relatively slow binding of lidocaine to the inactivated state of the channel. Also, it is interesting to notice that steady-state block at  $+31$  mV is about the same as at  $-69$  mV, as if lidocaine binding to the inactivated state were not significantly voltage dependent.

Fig. 9B shows a repetition of the experiment, but this time with a much higher lidocaine concentration ( $200 \mu\text{M}$ ) and also a higher pH (8.1 instead of 7.0). Under these conditions, there is a clear voltage dependence to the development of block. At  $-40$  mV, where channels are activated, there is a very rapid phase, so that a 10-ms conditioning pulse has already produced block to 65% of the current with no conditioning pulse, as if there were rapid block of channels during the time they were open. This rapid phase of block is lacking at  $-60$  mV. It is reasonable that increasing the lidocaine concentration and increasing the pH should lead to more open-channel block because

both of these changes will increase the total concentration of lidocaine inside the cells of the Purkinje fiber. On the basis of experiments in nerve and skeletal muscle, it is expected that open channels are blocked by internal anesthetic (e.g., Strichartz, 1973).

*pH Dependence of Lidocaine Binding Kinetics*

One of the major points to emerge from studies on nerve and skeletal muscle

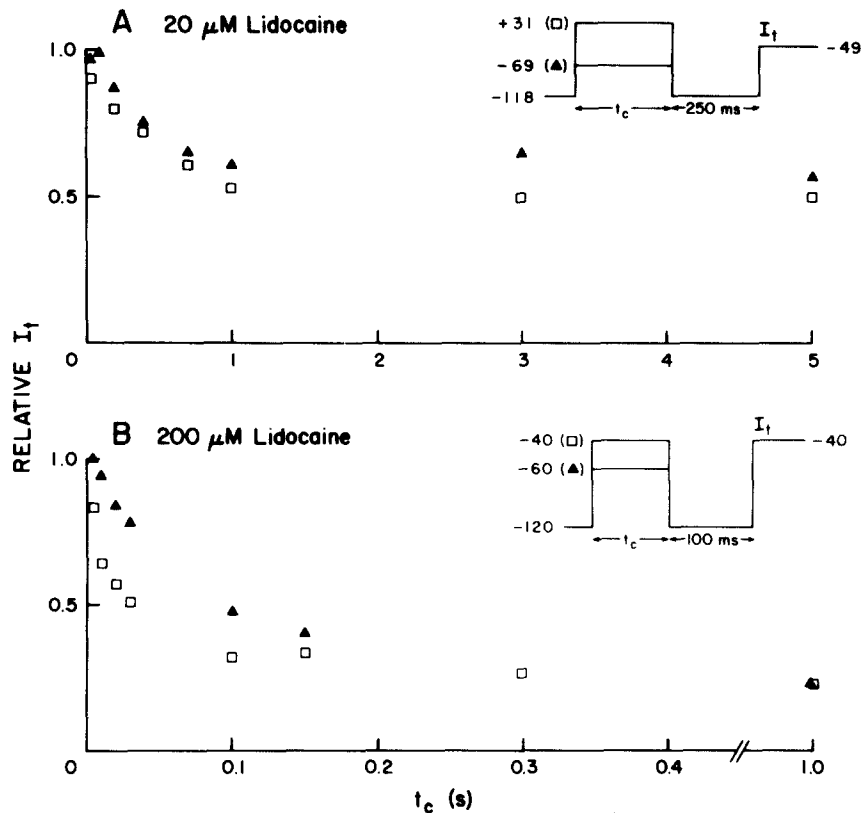

FIGURE 9. Time course of development of lidocaine block during depolarization. (A) Development of block by 20  $\mu$ M lidocaine at -69 (where channel opening was not detectable) and +31 mV (where channel activation is maximal). Preparation C95-2. 10 Na, pH 7.0, 18°C. (B) Development of block by 200  $\mu$ M lidocaine at -60 (no detectable sodium current) and at -40 mV (substantial sodium current) on a faster time scale. Preparation C95-3. 8.5 Na, pH 8.1, 17.5°C.

is that pH modulates the kinetics of lidocaine binding. Khodorov et al. (1976) observed that repriming in the presence of local anesthetics was slowed at lower external pH, and Schwarz et al. (1977) subsequently presented evidence that, first, pH affects the drug, not the receptor, and, second, that the effect is due to changes in the external pH, not the internal pH. Demonstration of similar pH effects in cardiac muscle would be strong evidence that lidocaine



binding is similar in all three tissues; already, recovery kinetics of  $\dot{V}_{\max}$  in guinea pig ventricle have been found to be slowed at lower pH (Grant et al., 1980).

Fig. 10 shows how pH affects both lidocaine binding and unbinding. Fig.

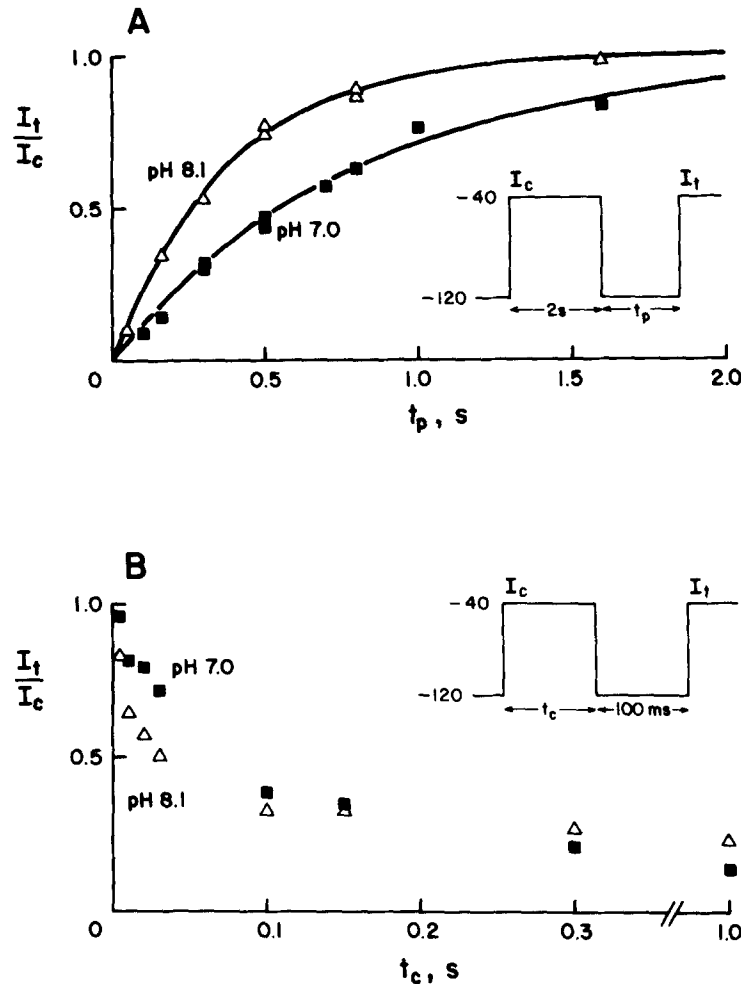

FIGURE 10. pH dependence of lidocaine blocking and unblocking kinetics. (A) pH dependence of repriming in presence of 200  $\mu$ M lidocaine.  $\tau$  decreased from 810 ms at pH 7.0 to 450 ms at pH 8.1. (B) pH dependence of development of block by 200  $\mu$ M lidocaine during a depolarization. Preparation C95-3. 8.5 Na, 17.5°C.

10A shows that repriming in the presence of 200  $\mu$ M lidocaine is considerably speeded up when the pH is increased, with the time constant decreasing from 0.81 s at pH 7.0 to 0.45 s at pH 8.1. (Although we did not examine it, repriming in the absence of lidocaine would be expected to be *slowed* slightly by such an increase of pH, if one extrapolates from studies with nerve

[Courtney, 1979b].) The effect of pH is quantitatively similar to those described in nerve for other tertiary amine local anesthetics by Khodorov and his collaborators (1976), and the magnitude of the change also seems consistent with the  $\dot{V}_{\max}$  data obtained from guinea pig ventricle by Grant et al. (1980). (Although  $\text{pH}_i$  probably changes with  $\text{pH}_o$  in our experiments [Ellis and Thomas, 1976; Deitmer and Ellis, 1980b], the model of Schwarz et al. [1977] predicts that possible changes in  $\text{pH}_i$  are unimportant. According to that model, decreasing  $\text{pH}_o$  slows repriming because external protons bind to lidocaine in the sodium channels and consequently slow the rate at which lidocaine can unbind from these sites. However, there is no direct evidence that lidocaine binding is independent of  $\text{pH}_i$  in myocardial cells.) Fig. 10B, from the same experiment as part A, shows that increasing the pH also speeds up the onset of lidocaine block during a depolarizing conditioning pulse, as one might expect from an increase in internal lidocaine concentration. This directly demonstrates that pH influences the development of lidocaine block, as well as its recovery, and confirms the suggestion of Schwarz et al. (1977) that pH modulation of use dependence kinetics could be due to a combination of both effects.

## DISCUSSION

### *Strong Binding to Inactivated Channels*

The main conclusion from our work is that lidocaine binds very strongly to cardiac sodium channels when the channels are inactivated. We estimated the strength of binding to inactivated channels by three complementary experimental protocols.

The most direct determination of binding to the inactivated state is the measurement of steady-state block at a depolarized holding potential (Fig. 5). This experiment, performed in full  $[\text{Na}]_o$ , was particularly sensitive to drug binding at low concentrations. Since the block is measured in the steady state, the experiment reports all drug binding to the inactivated state, even if (for example) the bound channels were to reprime quickly or if there were more than one bound state of the channel. No assumptions about the mechanism or kinetics of binding are necessary.

The shift in the availability curve caused by lidocaine (Figs. 6 and 7) is another steady-state method of determining lidocaine binding to the inactivated state. The experiments complement the results in Fig. 5 since they were performed in low  $[\text{Na}]_o$  and allowed accurate measurements using high drug concentrations. However, the determination of inactivated-state drug binding from the shift in the availability curve is less direct in that it requires a particular diagram of channel states and also an estimate of binding to the resting state.

Determination of inactivated-state binding using the zero-time intercept of slow repriming (Figs. 2 and 4) requires the assumption that all drug-bound channels reprime slowly. If, instead, some fraction of the drug-bound channels reprimed quickly, this technique might underestimate binding to the inactivated state. In fact, the apparent  $K_d$  of 10  $\mu\text{M}$  estimated by this method is

virtually identical with those estimated by the two steady-state methods, which suggests that all drug-bound channels really do reprime slowly.

All of our results were consistent with simple 1:1 binding to a single inactivated state. Other evidence from a variety of preparations has suggested the existence of multiple inactivated states (Chiu, 1977; Armstrong and Bezanilla, 1977; Brown et al., 1981; C. J. Cohen et al., 1981). Our data do not argue against multiple inactivated states; many such models could be formulated that would give apparent 1:1 binding with a single phase of slow repriming. It is, for example, difficult to rule out the possibility that lidocaine might preferentially bind to a slow inactivated state: it is intriguing that the slow repriming induced by lidocaine has a similar time course as the small amount of slow repriming that is present without drug (Fig. 2), but, on the other hand, we found no obvious correlation between the amount of slow inactivation present in the control and the apparent affinity of lidocaine for the inactivated state. Until the details of sodium channel inactivation are worked out, it is simplest to interpret our data as 1:1 binding to a single inactivated state.

These results may help settle continued controversy about whether therapeutic levels of lidocaine can significantly block cardiac sodium channels (Davis and Temte, 1969; Bigger and Mandel, 1970; Singh and Vaughan-Williams, 1971; Arnsdorf, 1976; Hauswirth and Singh, 1979). Two factors may have contributed to earlier underestimates of the sensitivity of sodium channels to lidocaine. First,  $\dot{V}_{\max}$  is not a very sensitive index of block while  $g_{\text{Na}}$  remains relatively large. For example, under the conditions used here, 50% reduction of  $g_{\text{Na}}$  by tetrodotoxin (TTX) produced only a 10% drop in  $\dot{V}_{\max}$  (Bean et al., 1982). Second, the apparent affinity for lidocaine ( $1/K_{\text{app}}$ ) will depend strongly on the apportionment of channels between resting and inactivated states (comprising fractions  $h$  and  $1 - h$ , respectively). At equilibrium,

$$\frac{1}{K_{\text{app}}} = \frac{h}{K_{\text{R}}} + \frac{1 - h}{K_{\text{I}}} \quad (1)$$

Over the range where inactivation is steeply voltage dependent, small changes in membrane potential will strongly influence the relative weights of  $1/K_{\text{R}}$  and  $1/K_{\text{I}}$ , the affinities for resting and inactivated channels, and thereby alter the apparent affinity. It is not surprising, then, that the sensitivity to lidocaine or related drugs is markedly enhanced when the membrane is depolarized by applied current (Weidmann, 1955; Weld and Bigger, 1975), elevated  $[\text{K}]_o$  (Singh and Vaughan-Williams, 1971; Brennan et al., 1978; Oshita et al., 1980), or experimental ischemia (Kupersmith et al., 1975).

Strong binding to inactivated Na channels may also be expressed by lidocaine's effect on steady-state current through Na channels. This steady current helps support the action potential plateau in Purkinje fibers; it is blocked by TTX (Dudel et al., 1967; Coraboeuf et al., 1979; Attwell et al., 1979) with the same sensitivity (Colatsky and Gadsby, 1980) as excitatory  $I_{\text{Na}}$  (C. J. Cohen et al., 1981). Lidocaine also blocks the steady Na channel current: it mimics the effect of TTX, and its effect is occluded by TTX, as shown

recently by Colatsky (1982) and Carmeliet and Saikawa (1982). These investigators found that the response to lidocaine was nearly maximal at  $\sim 20 \mu\text{M}$ . This fits well with our estimate of  $K_I = 10 \mu\text{M}$  and supports the idea that the steady plateau Na current flows through the same channels responsible for the fast upstroke.

Block of steady Na channel current seems to be the main factor in the abbreviation of the Purkinje fiber action potential by lidocaine. It may also explain lidocaine's repolarizing effect in partially depolarized Purkinje tissue (Weld and Bigger, 1976; Gadsby and Cranefield, 1977). At therapeutic concentrations, lidocaine does not affect slow inward current (Brennan et al., 1978) and has only slight effects on delayed rectification (Colatsky, 1982). In fact, besides sodium channels, the only channels substantially affected by clinical concentrations of lidocaine are those underlying pacemaker activity (Weld and Bigger, 1976; Carmeliet and Saikawa, 1982).

#### *Effects on Repriming and Availability*

Our finding that lidocaine slows sodium channel repriming agrees with previous work on cardiac tissue using measurements of  $\dot{V}_{\text{max}}$  (Chen et al., 1975; Weld and Bigger, 1975; Iven and Brasch, 1977; Grant et al., 1980; Oshita et al., 1980) or  $I_{\text{Na}}$  (Lee et al., 1981). In our experiments, higher lidocaine concentrations merely increased the amplitude of the slow phase of repriming without slowing its time constant, just as expected from the modulated-receptor hypothesis for lidocaine binding to sodium channels. This is in contrast to previous  $\dot{V}_{\text{max}}$  papers that reported that the time constant of the slow phase of repriming increases with lidocaine concentration (Chen et al., 1975; Grant et al., 1980; but see Oshita, 1980). The discrepancy can probably be explained by the difference in experimental methods. The apparent change in time constant with  $\dot{V}_{\text{max}}$  would be expected from the nonlinear relationship between  $\dot{V}_{\text{max}}$  and available sodium conductance.<sup>1</sup> The time constant reported by  $\dot{V}_{\text{max}}$  measurements should gradually approach the genuine time constant of repriming as the lidocaine block increases.

In other respects, our voltage-clamp data on repriming fit well with earlier  $\dot{V}_{\text{max}}$  results. The slow phase of  $I_{\text{Na}}$  repriming induced by lidocaine becomes faster with membrane hyperpolarization (Fig. 8) and increased pH (Fig. 10A), in agreement with corresponding  $\dot{V}_{\text{max}}$  experiments in guinea pig ventricle (Chen et al., 1975; Oshita et al., 1980; Grant et al., 1980). The difference in experimental method between voltage-clamp and  $\dot{V}_{\text{max}}$  experiments is probably least important for the experiments that measured shifts in the availability curve.<sup>2</sup> In guinea pig ventricle, Chen et al. (1975) found a 3.5-mV shift with

<sup>2</sup> Even if  $\dot{V}_{\text{max}}$  is a very nonlinear measure of  $g_{\text{Na}}$ , the displacement of  $\dot{V}_{\text{max}}$  availability curve can accurately reflect the shift of the true  $I_{\text{Na}}$  availability curve provided that three conditions are met: (a) the measurements are made using prepulses long enough to establish a steady state, (b) there is little or no block of sodium channels at very negative potentials, and (c) lidocaine does not change the shape of the measured  $I_{\text{Na}}$  availability curve. We have established the validity of the second and third conditions for lidocaine concentrations below  $50 \mu\text{M}$  or so (Fig. 6), and the first condition was satisfied in a number of  $\dot{V}_{\text{max}}$  studies that varied external  $\text{K}^+$  to change the membrane potential.

17  $\mu\text{M}$  lidocaine; in sheep Purkinje fibers, Weld and Bigger (1975) found an average shift of 4.4 mV with 21  $\mu\text{M}$  lidocaine; in dog Purkinje fibers, G. A. Gintant and B. F. Hoffman (personal communication) found a 6.2-mV shift with 40  $\mu\text{M}$  lidocaine. These results are very close to the shifts we found at similar concentrations, 4.7 mV at 20  $\mu\text{M}$  and 5.8 mV at 40  $\mu\text{M}$  lidocaine (Fig. 7). The close correspondence of these results is consistent with there being little or no difference in lidocaine binding among the various preparations and also little effect of the various differences in experimental conditions (for example, the lower temperature and external sodium in our experiments).

*Comparisons between Lidocaine Block in Heart, Nerve, and Skeletal Muscle*

**BINDING TO OPEN CHANNELS OR INACTIVATED CHANNELS** Previous descriptions of lidocaine effects have stressed different mechanisms for drug block within the broad framework of the modulated-receptor hypothesis (Table III). According to the model of Hondeghem and Katzung (1977),

TABLE III  
STATE-DEPENDENT LIDOCAINE BLOCK IN VARIOUS EXCITABLE CELLS

Preparation	Paper	$K_R$ $\mu\text{M}$	$K_I$ $\mu\text{M}$	Open channel block at 20 $\mu\text{M}$ lidocaine?
Frog node	Hille, 1977 Courtney, 1981	1,000	30*	—
Frog skeletal muscle	Schwartz et al., 1977	200	8	Little predicted
Guinea pig ventricular muscle model	Hondeghem and Katzung, 1977	2,500	40	Substantial amount predicted
Rabbit Purkinje	This paper	440	10	Little observed

\* Calculated from steady-state block at  $h_0 = 0.65$ , using  $K_R = 1,000 \mu\text{M}$ .

clinical concentrations of lidocaine produce use-dependent block in guinea pig ventricular muscle in large part by binding rapidly to open sodium channels. On the other hand, the skeletal muscle experiments of Schwarz et al. (1977) led to a model that predicts very little open-channel block at 20  $\mu\text{M}$  lidocaine; at this concentration, their scheme accounts for use dependence in terms of lidocaine interactions with inactivated channels (see also Courtney, 1981). Our estimates of  $K_R$  and  $K_I$  fall between the values proposed for lidocaine block in nerve and skeletal muscle; and, as predicted by the skeletal muscle model of Schwarz et al. (1977), rabbit Purkinje fibers display very little open-channel block at 20  $\mu\text{M}$  lidocaine. On the other hand, we found much stronger binding to resting and inactivated channels, and less open-channel block, than assumed by Hondeghem and Katzung (1977) in their working hypothesis for myocardium.

It is important to point out that the information in Table III comes from

widely different experimental approaches. Leaving aside results based on  $\dot{V}_{\max}$ , there are significant variations even among voltage-clamp studies. We know of no published work in nerve or skeletal muscle that describes lidocaine block using the direct voltage-clamp protocols illustrated in Figs. 4, 5, or 9. In these preparations, investigators usually study local anesthetic block at higher drug concentrations with trains of brief depolarizations that activate  $I_{\text{Na}}$  (see, however, Khodorov et al., 1976). For example, the skeletal muscle entries in Table III are extrapolations from measurements of use-dependent block with 1.5-ms voltage-clamp pulses at 200  $\mu\text{M}$  lidocaine.

With these caveats, the tentative conclusion is that cardiac sodium channels strongly resemble their counterparts in nerve and skeletal muscle in their response to lidocaine. This similarity between various tissues is particularly interesting because of clear differences in their interactions with TTX. When compared with channels in other membranes, cardiac sodium channels are unusual in two respects: (a) TTX block requires micromolar, not nanomolar, concentrations of toxin, and (b) the block is strikingly use dependent (Reuter et al., 1978; C. J. Cohen et al., 1981). Apparently, structural differences exist between TTX receptors in heart and other tissues (C. J. Cohen et al., 1981; Rogart et al., 1982), but these differences have little or no effect on lidocaine binding.

**TONIC BLOCK vs. USE-DEPENDENT BLOCK** In the only previous paper studying lidocaine block with newly improved methods for measuring cardiac  $I_{\text{Na}}$ , Lee et al. (1981) described the effect of 20  $\mu\text{M}$  lidocaine on single rat ventricular cells. They found a large degree of tonic block (40%), but very little additional use-dependent block (10%). This observation contrasts with our results in Fig. 1, as well as earlier  $\dot{V}_{\max}$  experiments, where similar lidocaine concentrations gave negligible tonic block and much greater use-dependent block (Chen and Gettes, 1976; Courtney, 1979a; Hondeghem and Katzung, 1980). The large amount of tonic block seen by Lee and his collaborators can be understood from the modulated-receptor model, since they used a holding potential ( $-80$  mV) at which  $\sim 70\%$  of the sodium channels were inactivated. Although it is less obvious, the smallness of the use dependence under their experimental conditions can also be explained by the modulated-receptor model.

Fig. 11 shows how the limiting degree of use dependence varies with the steady-state inactivation at the holding potential. The calculations are based on a very simple version of the modulated-receptor scheme, with realistic values for  $K_{\text{R}}$  and  $K_{\text{I}}$ . The left column describes the effect of 20  $\mu\text{M}$  lidocaine at a negative holding potential at which most channels are in their resting state. Here, the fractional degree of use-dependent block can be as great as 67%. The right column describes the effect of lidocaine at a holding potential where only 30% of the sodium channels are available in the absence of drug. In this case, there is substantial tonic block, but only very little extra use-dependent block is possible. This behavior can be explained as follows. At drug concentrations where binding to resting channels is negligible, both tonic block and use-dependent block are manifestations of lidocaine binding to

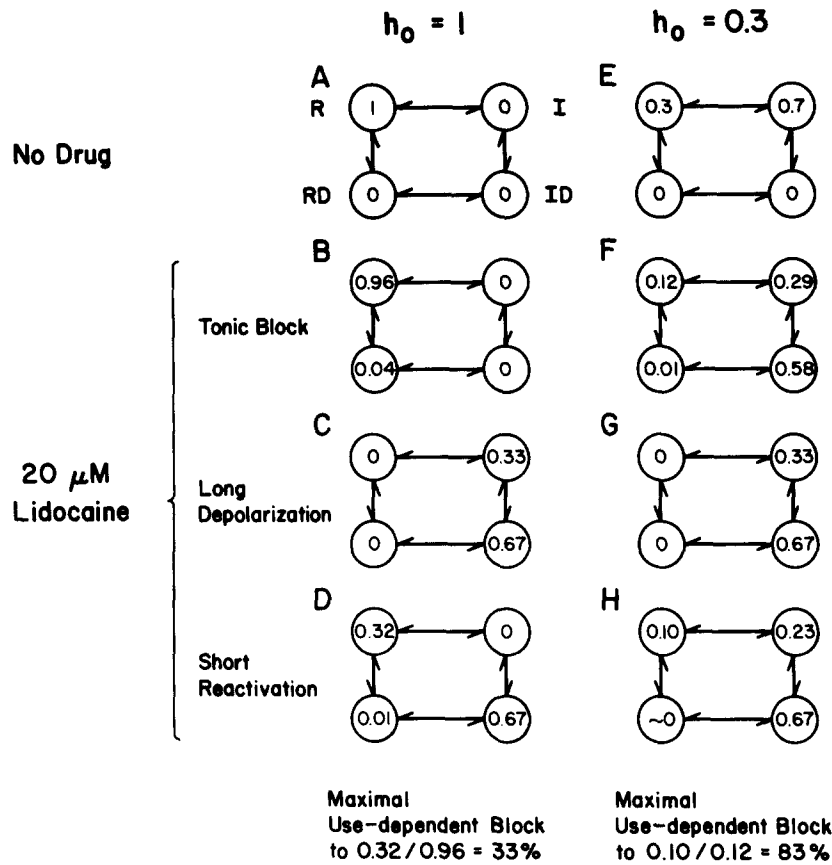

FIGURE 11. Occlusion of use-dependent block by tonic block. Each panel shows the expected distribution of channels between four states: resting (R), resting with drug bound (RD), inactivated (I), and inactivated with drug bound (ID). Binding of drug to the resting state is assumed to be governed by a  $K_d$  of 500  $\mu$ M, and binding to the inactivated state by a  $K_d$  of 10  $\mu$ M. Each column shows the expected distribution of channels under four conditions: in the absence of drug (A and E); with equilibrium binding at 20  $\mu$ M drug at the holding potential (B and F); after a long depolarization so that all channels are in the I and ID states (C and G); after a short repolarization, long enough so that normal removal of inactivation is complete (i.e., redistribution between R and I proceeds to completion), but short enough so that virtually no unbinding of drug occurs. For simplicity, it is assumed that there is no movement between ID and RD during the repolarization interval, but also that there is equilibrium binding of drug to R during this period; neither assumption significantly affects the outcome of the calculation. The calculation gives the limiting amount of block that could be obtained with any train of pulses: the long depolarization puts the maximum possible fraction of channels into the ID state, that corresponding to an equilibrium distribution of all channels between I and ID. In most experiments, there will be some reactivation between pulses, and the actual amount of use dependence will be less (compare Fig. 11, left, and Fig. 1). Also, since the rate of recovery from the drug-bound, inactivated state becomes faster at negative potentials (Fig. 8), it is possible that, experimentally, hyperpolarizing the membrane could produce less use dependence (due to faster recovery) or more use dependence (due to relief of tonic occlusion), or no effect.

inactivated channels. At a depolarized holding potential, where tonic block is considerable, most channels are already distributed between drug-free and drug-bound inactivated states; depolarizing pulses can only slightly increase the overall occupancy of inactivated states, and therefore, the limiting amount of use dependence is correspondingly small. Thus, for low lidocaine concentrations, the more tonic block there is, the less use-dependent block there can be; put in a different way, tonic block occludes use-dependent block.

*Comparisons Between Lidocaine and Tetrodotoxin*

Although lidocaine and TTX share the ability to block cardiac Na channels in a use-dependent manner (Reuter et al., 1978), voltage-clamp analysis has also revealed important differences in their mechanisms of action (C. J. Cohen et al., 1981; Bean et al., 1982). Table IV summarizes the main points of contrast. Unlike lidocaine, TTX blocks resting and inactivated Na channels of rabbit Purkinje fibers with much the same dissociation constant. Use-dependent and other kinetic effects arise because of differences in rates of

TABLE IV  
TTX AND LIDOCAINE BLOCK OF  $I_{Na}$  IN RABBIT PURKINJE FIBERS

	TTX	Lidocaine
Steady-state voltage dependence	No	Yes
Use dependence	Yes	Yes
Inactivation-linked?	All concentrations	All concentrations
Activation-linked?	All concentrations	Not at low concentrations
Voltage dependence of recovery from extra block	Little if any	Considerable

equilibration to resting and inactivated channels. It is as if channel inactivation restricted the access of the toxin molecule as it comes and goes from its receptor, without significantly altering the binding affinity itself. In the case of lidocaine, channel inactivation seems to influence both the strength and the speed of drug binding.

*Role of Na Channel Block in Lidocaine's Antiarrhythmic Action*

Lidocaine is often used in the treatment of ventricular premature depolarizations resulting from digitalis toxicity or cardiac disease (see, for example, Rosen et al., 1975*b*). In both types of arrhythmia, block of Na channels seems to be an important factor in lidocaine's therapeutic action.

**ARRHYTHMIAS ASSOCIATED WITH DIGITALIS TOXICITY** Cardiac glycosides (or catecholamines) can produce a form of abnormal automaticity involving oscillatory afterpotentials (Ferrier, 1977; Rosen et al., 1975*a*; Zipes et al., 1974). These potentials are generated by oscillatory transient inward current,  $I_T$ , carried by Ca-activated, nonselective cation channels (see Kass et al.,



1978a, b; Colquhoun et al., 1981). Lidocaine has been shown to suppress oscillatory afterpotentials (Rosen and Danilo, 1980) as well as TI (Eisner and Lederer, 1979). An indirect mechanism, involving block of sodium influx through Na channels and reduced intracellular Na activity  $a_{\text{Na}}^i$  may be important. Thus, (a) TTX both mimics (Lederer, 1976; Kass et al., 1978b) and occludes (B. P. Bean, E. Marban, and R. W. Tsien, unpublished data) lidocaine's effect on TI, and (b) TI magnitude varies with  $a_{\text{Na}}^i$  with the same relationship whether  $a_{\text{Na}}^i$  is decreased by lidocaine or Na pump stimulation (Sheu et al., 1982). One mechanism, then, for the suppression of TI is as follows: lidocaine reduces influx through fast Na channels, lowers  $a_{\text{Na}}^i$  (Deitmer and Ellis, 1980a), and shortens action potential duration;  $a_{\text{Ca}}^i$  falls because Ca influx during the action potential is decreased and calcium efflux via Na-Ca exchange is increased; the relief of Ca overload diminishes oscillatory Ca release from intracellular stores and thereby reduces TI.

#### RE-ENTRANT ARRHYTHMIAS ACCOMPANYING MYOCARDIAL INFARCTION

Experimental animal models suggest that lidocaine acts by decreasing excitability in areas of damaged myocardium, while having little effect on healthy regions (Hondeghe et al., 1974; Sasyniuk and Kus, 1974; Lazzara et al., 1978; Wald et al., 1980; see Rosen, 1979, for review). Lidocaine can abolish re-entrant circuits arising from unidirectional block in ischemic regions (see Rosen et al., 1975) by converting unidirectional block to bidirectional block (Cardinal et al., 1981). As previously suggested, lidocaine has the key property in this application of potently blocking impulse conduction in depolarized cells (as in ischemic tissue, where  $[\text{K}]_o$  is abnormally high [see Hill and Gettes, 1980]), while negligibly affecting conduction in normal, well-polarized tissue. Our results provide quantitative support for this interpretation: even the lowest clinically effective dose of lidocaine, 5  $\mu\text{M}$ , can block sodium current by almost 50% at a depolarized holding potential, whereas the highest therapeutic level, 20  $\mu\text{M}$ , has almost no effect at a negative holding potential (Fig. 5).

#### *How Important Is Use Dependence as an Antiarrhythmic Mechanism?*

Use dependence is a striking characteristic of sodium channel block by lidocaine and other local anesthetics, so it is natural to suppose that it is a key factor in antiarrhythmic action. The changes in repriming kinetics that underly use dependence could in principle increase the effective refractory period (ERP) and prevent the propagation of premature impulses. However, there is little evidence for such a mechanism, and several reasons why its importance might be quite limited.

In ischemic, depolarized tissue, the main effect of lidocaine is tonic block; additional changes in the time course of repriming are restricted because tonic block occludes use-dependent block (Fig. 11E-H). In studies of ischemic tissue from experimental animals, lidocaine decreased ERP in Purkinje fibers, because of action potential shortening (Allen et al., 1978) and increased ERP by 10-25% in ventricle (Kupersmith et al., 1975; Kupersmith, 1979). Much of the increase in ventricular ERP may have been caused by tonic block.

Changes in the ERP of well-polarized tissue must also be considered because these could determine whether a premature impulse spreads. Here there is much more room for use dependence. However, during exposure to lidocaine, slowing of repriming is apparently counteracted by a decrease in action potential duration; the effect observed in healthy tissue is a net *decrease* in ERP (Davis and Temte, 1969; Bigger and Mandel, 1970; Allen et al., 1978).

Thus, studies *in vitro* leave open the possibility that lidocaine's antiarrhythmic effects are not directly related to its use-dependent properties at all. This possibility can be tested with the help of the neutral anesthetic benzocaine, which produces voltage-dependent, tonic block like lidocaine, but little use dependence (Schwarz et al., 1977; Sanchez-Chapula et al., 1982). If use dependence were relatively unimportant, benzocaine should closely mimic lidocaine in counteracting model arrhythmias in experimental animals and isolated tissues.

*Received for publication 9 July 1982 and in revised form 16 December 1982.*

#### REFERENCES

- Allen, J. D., F. J. Brennan, and A. L. Wit. 1978. Actions of lidocaine on transmembrane potentials of subendocardial Purkinje fibers surviving in infarcted canine hearts. *Circ. Res.* 43:470-481.
- Armstrong, C. M., and F. Bezanilla. 1977. Inactivation of the sodium channel. II. Gating current experiments. *J. Gen. Physiol.* 70:567-590.
- Arnsdorf, M. F. 1976. Electrophysiologic properties of antidysrhythmic drugs as a rational basis for therapy. *Med. Clin. N. Am.* 60:213-232.
- Attwell, D., I. Cohen, D. Eisner, M. Ohba, and C. Ojeda. 1979. The steady-state TTX-sensitive ("window") sodium current in cardiac Purkinje fibers. *Pflügers Arch. Eur. J. Physiol.* 379:137-142.
- Baer, M., P. M. Best, and H. Reuter. 1976. Voltage-dependent action of tetrodotoxin in mammalian cardiac muscle. *Nature (Lond.)*. 263:344-345.
- Bean, B. P., C. J. Cohen, and R. W. Tsien. 1981. Lidocaine binding to resting and inactivated cardiac sodium channels. *Biophys. J.* 33:208a. (Abstr.)
- Bean, B. P., C. J. Cohen, and R. W. Tsien. 1982. Block of cardiac sodium channels by TTX and lidocaine: sodium current and  $\dot{V}_{\max}$  experiments. In *Normal and Abnormal Conduction in the Heart*. B. F. Hoffman, M. Lieberman, and A. Paes de Carvalho, editors. Futura Publishing Co., Inc., Mt. Kisco, NY.
- Bellet, S., L. Roman, J. B. Kostis, and D. Fleischmann. 1971. Intramuscular lidocaine in the therapy of ventricular arrhythmias. *Am. J. Cardiol.* 27:291-293.
- Bigger, J. T., and W. J. Mandel. 1970. Effect of lidocaine on the electrophysiological properties of ventricular muscle and Purkinje fibers. *J. Clin. Invest.* 49:63-77.
- Brennan, F. J., P. F. Cranefield, and A. L. Wit. 1978. Effects of lidocaine on slow response and depressed fast response action potentials of canine cardiac Purkinje fibers. *J. Pharmacol. Exp. Ther.* 204:312-324.
- Brown, A. M., K. S. Lee, and T. Powell. 1981. Sodium current in single rat heart muscle cells. *J. Physiol. (Lond.)*. 318:479-500.
- Cardinal, R., M. J. Janse, I. Van Eeden, G. Werner, C. Naumann d'Alnoncourt, and D.

- Durrer. 1981. The effects of lidocaine on intracellular and extracellular potentials, activation, and ventricular arrhythmias during acute regional ischemia in the isolated porcine heart. *Circ. Res.* 49:792-806.
- Carmeliet, E., and T. Saikawa. 1982. Shortening of the action potential and reduction of pacemaker activity by lidocaine, quinidine and procainamide in sheep cardiac Purkinje fibers. An effect on Na or K currents? *Circ. Res.* 50:257-272.
- Chen, C.-M., and L. S. Gettes. 1976. Combined effects of rate, membrane potential, and drugs on maximum rate of rise ( $\dot{V}_{\max}$ ) of action potential upstroke of guinea pig papillary muscle. *Circ. Res.* 38:464-469.
- Chen, C.-M., L. S. Gettes, and B. Katzung. 1975. Effect of lidocaine and quinidine on steady-state characteristics and recovery kinetics of  $(dv/dt)_{\max}$  in guinea pig ventricular myocardium. *Circ. Res.* 37:20-29.
- Chiu, S. Y. 1977. Inactivation of sodium channels: second order kinetics in myelinated nerve. *J. Physiol. (Lond.)*. 273:573-596.
- Cohen, C. J., B. P. Bean, T. J. Colatsky, and R. W. Tsien. 1981. Tetrodotoxin block of sodium channels in rabbit Purkinje fibers. Interactions between toxin binding and channel gating. *J. Gen. Physiol.* 78:383-411.
- Cohen, I. S., D. Attwell, and G. R. Strichartz. 1981. The dependence of the maximal rate of rise of the action potential upstroke on membrane properties. *Proc. R. Soc. Lond. B Biol. Sci.* 214:85-98.
- Cohen, I. S., and G. R. Strichartz. 1977. On the voltage dependent action of tetrodotoxin. *Biophys. J.* 17:275-279.
- Colatsky, T. J. 1980. Voltage clamp measurements of sodium channel properties in rabbit cardiac Purkinje fibers. *J. Physiol. (Lond.)*. 305:215-234.
- Colatsky, T. J. 1982. Mechanisms of action of lidocaine and quinidine on action potential duration in rabbit cardiac Purkinje fibers. An effect on steady-state sodium currents? *Circ. Res.* 50:17-27.
- Colatsky, T. J., and D. C. Gadsby. 1980. Is tetrodotoxin block of background sodium channels in cardiac Purkinje fibers voltage-dependent? *J. Physiol. (Lond.)*. 306:20P. (Abstr.)
- Colatsky, T. J., and R. W. Tsien. 1979a. Electrical properties associated with wide intercellular clefts in rabbit Purkinje fibers. *J. Physiol. (Lond.)*. 290:227-252.
- Colatsky, T. J., and R. W. Tsien. 1979b. Sodium channels in rabbit cardiac Purkinje fibers. *Nature (Lond.)*. 278:265-268.
- Colquhoun, D. 1971. Lectures on Biostatistics. Clarendon Press, Oxford.
- Colquhoun, D., E. Neher, H. Reuter, and C. F. Stevens. 1981. Inward current channels activated by Ca in cultured cardiac cells. *Nature (Lond.)*. 294:752-754.
- Coraboeuf, E., E. Deroubaix, and A. Coulombe. 1979. Effect of tetrodotoxin on action potentials of the conducting system in the dog heart. *Am. J. Physiol.* 237:H561-H567.
- Courtney, K. R. 1975. Mechanism of frequency-dependent inhibition of sodium currents in frog myelinated nerve by the lidocaine derivative GEA 968. *J. Pharmacol. Exp. Ther.* 195:225-236.
- Courtney, K. R. 1979a. Fast frequency-dependent block of action potential upstroke in rabbit atrium by small local anesthetics. *Life Sci.* 24:1581-1588.
- Courtney, K. R. 1979b. Extracellular pH selectively modulates recovery from sodium inactivation in frog myelinated nerve. *Biophys. J.* 28:363-368.
- Courtney, K. R. 1981. Comparative actions of mexiletine on sodium channels in nerve, skeletal and cardiac muscle. *Eur. J. Pharmacol.* 74:9-18.

- Davis, L. D., and J. V. Temte. 1969. Electrophysiological actions of lidocaine on canine ventricular muscle and Purkinje fibers. *Circ. Res.* 44:639-655.
- Deitmer, J. W., and D. Ellis. 1980a. The intracellular sodium activity of sheep heart Purkinje fibers: effects of local anaesthetics and tetrodotoxin. *J. Physiol. (Lond.)*. 300:269-282.
- Deitmer, J. W., and D. Ellis. 1980b. Interactions between the regulation of the intracellular pH and sodium activity of sheep cardiac Purkinje fibers. *J. Physiol. (Lond.)*. 304:471-488.
- Dudel, J., K. Peper, R. Rüdell, and W. Trautwein. 1967. The effect of tetrodotoxin on the membrane current in cardiac muscle (Purkinje fibers). *Pflügers Arch. Eur. J. Physiol.* 295:213-226.
- Eisner, D. A., and W. J. Lederer. 1979. A cellular basis for lidocaine's anti-arrhythmic action. *J. Physiol. (Lond.)*. 295:25P. (Abstr.)
- Ellis, D., and R. C. Thomas. 1976. Direct measurement of the intracellular pH of mammalian cardiac muscle. *J. Physiol. (Lond.)*. 262:755-771.
- Fan, S. F., and T. P. Feng. 1951. The relief of the cocaine block in nerve by anodal current. *Sci. Record.* 4:169-171.
- Ferrier, G. R. 1977. Digitalis arrhythmias: role of oscillatory after potentials. *Prog. Cardiovasc. Dis.* 19:459-474.
- Gadsby, D. G., and P. F. Cranefield. 1977. Two levels of resting potential in cardiac Purkinje fibers. *J. Gen. Physiol.* 70:725-746.
- Gettes, L. S. 1981. Physiology and pharmacology of antiarrhythmic drugs. *Hosp. Pract.* 16:89-101.
- Gianelly, R., J. O. van der Groeben, A. P. Spivack, and D. C. Harrison. 1967. Effect of lidocaine on ventricular arrhythmias in patients with coronary heart disease. *N. Engl. J. Med.* 277:1215-1219.
- Grant, A. O., L. J. Strauss, A. G. Wallace, and H. C. Strauss. 1980. The influence of pH on the electrophysiological effects of lidocaine in guinea pig ventricular myocardium. *Circ. Res.* 47:542-550.
- Hauswirth, O., and B. N. Singh. 1979. Ionic mechanisms in heart muscle in relation to the genesis and the pharmacological control of cardiac arrhythmias. *Pharmacol. Rev.* 30:5-63.
- Heistracher, P. 1971. Mechanism of action of antifibrillatory drugs. *Naunyn-Schmiedeberg's Arch. Pharmacol.* 269:199-212.
- Hill, J. L., and L. S. Gettes. 1980. Effect of acute coronary artery occlusion on local myocardial extracellular  $K^+$  activity in swine. *Circulation.* 61:768-778.
- Hille, B. 1971. The permeability of the sodium channel to organic cations in myelinated nerve. *J. Gen. Physiol.* 58:599-619.
- Hille, B. 1977. Local anesthetics: hydrophilic and hydrophobic pathways for the drug-receptor reaction. *J. Gen. Physiol.* 69:497-515.
- Hille, B. 1978. Local anesthetic action on inactivation of the Na channel in nerve and skeletal muscle. In *Biophysical Aspects of Cardiac Muscle*. M. Morad, editor. Academic Press, Inc., New York. 55-74.
- Hodgkin, A. L., and A. F. Huxley. 1952. A quantitative description of membrane current and its application to conduction and excitation in nerve. *J. Physiol. (Lond.)*. 117:500-544.
- Hondeghem, L. M., A. O. Grant, and R. A. Jensen. 1974. Antiarrhythmic drug action: selective depression of hypoxic cardiac cells. *Am. Heart J.* 87:602-605.
- Hondeghem, L. M., and B. G. Katzung. 1977. Time- and voltage-dependent interactions of antiarrhythmic drugs with cardiac sodium channels. *Biochim. Biophys. Acta.* 472:373-398.
- Hondeghem, L. M., and B. G. Katzung. 1980. Test of a model of antiarrhythmic drug action. Effects of quinidine and lidocaine on myocardial conduction. *Circulation.* 61:1217-1224.

- Iven, H., and H. Brasch. 1977. Effects of the local anesthetics brufacain and lidocaine on transmembrane action potentials, refractory period and reactivation of the sodium system in guinea pig heart muscle. *Naunyn-Schmiedeberg's Arch. Pharmacol.* 297:153-161.
- Jewitt, D. E., Y. Kishon, and M. Thomas. 1968. Lignocaine in the management of arrhythmias after acute myocardial infarction. *Lancet.* I:266-270.
- Johnson, E. A., and M. C. McKinnon. 1957. The differential effect of quinidine and pyrilamine on the myocardial action potential at various rates of stimulation. *J. Pharmacol. Exp. Ther.* 120:460-468.
- Kass, R. S., R. W. Tsien, and R. Weingart. 1978a. Role of calcium ions in transient inward currents and after contractions induced by strophanthidin in cardiac Purkinje fibers. *J. Physiol. (Lond.)*. 281:187-208.
- Kass, R. S., R. W. Tsien, and R. Weingart. 1978b. Ionic basis of transient inward current induced by stophanthidin in cardiac Purkinje fibers. *J. Physiol. (Lond.)*. 281:209-229.
- Khodorov, B. I., and V. I. Belyaev. 1967. Effect of membrane hyperpolarization and of calcium and nickel ions on electrical activity of the single node of Ranvier on exposure to tetrodotoxin and procaine. *Biophysics (Engl. Transl. Biofizika)*. 12:981-992.
- Khodorov, B. L., L. Shishkova, E. Peganov, and S. Revenko. 1976. Inhibition of sodium currents in frog Ranvier node treated with local anesthetics. Role of slow sodium inactivation. *Biochim. Biophys. Acta.* 433:409-435.
- Kupersmith, J. 1979. Electrophysiological and antiarrhythmic effects of lidocaine in canine acute myocardial ischemia. *Am. Heart J.* 97:360-366.
- Kupersmith, J., E. M. Antman, and B. F. Hoffman. 1975. In vivo electrophysiological effects of lidocaine in canine acute myocardial infarction. *Circ. Res.* 36:84-91.
- Lazzara, R., R. R. Hope, N. El-Sherif, and B. J. Scherlag. 1978. Effects of lidocaine on hypoxic and ischemic myocardial cells. *Am. J. Cardiol.* 41:872-879.
- Lederer, W. J. 1976. The ionic basis of arrhythmogenic effects of cardiotonic steroids in cardiac Purkinje fibers. Ph.D. Thesis, Yale University, New Haven, CT.
- Lee, K. S., J. R. Hume, W. Giles, and A. M. Brown. 1981. Sodium current depression by lidocaine and quinidine in isolated ventricular cells. *Nature (Lond.)*. 291:325-327.
- Oshita, S., H. Sada, M. Kojima, and T. Ban. 1980. Effects of tocainide and lidocaine on the transmembrane action potentials as related to external potassium and calcium concentrations in guinea-pig papillary muscles. *Naunyn-Schmiedeberg's Arch. Pharmacol.* 314:67-82.
- Reuter, H., M. Baer, and P. M. Best. 1978. Voltage dependence of TTX action in mammalian cardiac muscle. In *Biophysical Aspects of Cardiac Muscle*. M. Morad, editor. Academic Press, Inc., New York. 129-142.
- Rogart, R. B., L. Regan, and J. B. Galper. 1982. Cardiac and nerve Na<sup>+</sup> channel differ at their saxitoxin binding sites. *Biophys. J.* 37:101a. (Abstr.)
- Rosen, M. R. 1979. Cardiac drugs: antiarrhythmic drugs. *Curr. Cardiol.* 1:259-303.
- Rosen, M. R., and P. Danilo, Jr. 1980. Effects of tetrodotoxin, lidocaine, verapamil, and AHR-2666 on ouabain-induced delayed after depolarizations in canine Purkinje fibers. *Circ. Res.* 46:117-124.
- Rosen, M. R., B. F. Hoffman, and A. L. Wit. 1975a. Electrophysiology and pharmacology of cardiac arrhythmias. IV. Cardiac antiarrhythmic and toxic effects of digitalis. *Am. Heart J.* 89:391-399.
- Rosen, M. R., B. F. Hoffman, and A. L. Wit. 1975b. Electrophysiology and pharmacology of cardiac arrhythmias. V. Cardiac antiarrhythmic effects of lidocaine. *Am. Heart J.* 89:526-536.
- Sanchez-Chapula, J., Y. Tsuda, I. Josephson, and A. M. Brown. 1982. Effects of lidocaine and benzocaine on cardiac sodium current. *Biophys. J.* 37:238a. (Abstr.)

- Sasyniuk, B. I., and T. Kus. 1974. Comparison of the effects of lidocaine on the electrophysiological properties of normal Purkinje fibers and those surviving acute myocardial infarction. *Fed. Proc.* 33:476. (Abstr.)
- Schmidtmayer, J., and W. Ulbricht. 1980. Interaction of lidocaine and benzocaine in blocking sodium channels. *Pflügers Arch. Eur. J. Physiol.* 387:47-54.
- Schwarz, W., P. T. Palade, and B. Hille. 1977. Local anesthetics. Effect of pH on use-dependent block of sodium channels in frog muscle. *Biophys. J.* 20:343-368.
- Sheu, S.-S., W. J. Lederer, and D. A. Eisner. 1982. How does lidocaine reduce the oscillatory transient inward current in sheep cardiac Purkinje fibers? *Biophys. J.* 37:343a. (Abstr.)
- Singh, B. N., and E. M. Vaughan-Williams. 1971. Effect of altering potassium concentration on the action of lidocaine and diphenylhydantoin on rabbit atrial and ventricular muscle. *Circ. Res.* 29:286-295.
- Strichartz, G. R. 1973. The inhibition of sodium currents in myelinated nerve by quaternary derivatives of lidocaine. *J. Gen. Physiol.* 62:37-57.
- Ulbricht, W., and H.-H. Wagner. 1975. The influence of pH on equilibrium effects of tetrodotoxin on myelinated nerve fibers of *Rana esculenta*. *J. Physiol. (Lond.)* 252:159-184.
- Wald, R. W., M. B. Waxman, and E. Downar. 1980. The effect of antiarrhythmic drugs on depressed conduction and unidirectional block in sheep Purkinje fibers. *Circ. Res.* 46:612-619.
- Weidmann, S. 1955. The effects of calcium ions and local anesthetics on electrical properties of Purkinje fibers. *J. Physiol. (Lond.)* 129:568-582.
- Weld, F. M., and J. T. Bigger. 1975. Effect of lidocaine on the early inward transient current in sheep cardiac Purkinje fibers. *Circ. Res.* 37:630-639.
- Weld, F. M., and J. T. Bigger. 1976. The effect of lidocaine on diastolic transmembrane currents determining pacemaker depolarization in cardiac Purkinje fibers. *Circ. Res.* 38:203-208.
- Zipes, D. P., E. Arbel, R. F. Knope, and G. K. Moe. 1974. Accelerated cardiac escape rhythms caused by ouabain intoxication. *Am. J. Cardiol.* 33:248-253.