

The Three Members of the Selectin Receptor Family Recognize a Common Carbohydrate Epitope, the Sialyl Lewis^x Oligosaccharide

Carroll Foxall,* Susan R. Watson,† Donald Dowbenko,‡ Christopher Fennie,‡ Laurence A. Lasky,‡ Makoto Kiso,§ Akira Hasegawa,§ Darwin Asa,* and Brian K. Brandley*

*Glycomed, Inc., Alameda, California 94501; †Genentech, Inc., South San Francisco, California 94080; and ‡Department of Applied Bioorganic Chemistry, Gifu University, Gifu 501-11, Japan

Abstract. The selectins (lectin-EGF-complement binding-cell adhesion molecules [LEC-CAMs]) are a family of mammalian receptors implicated in the initial interactions between leukocytes and vascular endothelia, leading to lymphocyte homing, platelet binding, and neutrophil extravasation. The three known selectins, L-selectin (leukocyte adhesion molecule-1 [LECAM-1]), E-selectin (endothelial-leukocyte adhesion molecule-1 [ELAM-1]), and P-selectin (GMP-140) share structural features that include a calcium-dependent lectin domain. The sialyl Lewis^x carbohydrate epitope has been reported as a ligand for both E- and P-selectins. Although L-selectin has been demonstrated

to bind to carbohydrates, structural features of potential mammalian carbohydrate ligand(s) have not been well defined. Using an ELISA developed with a sialyl Lewis^x-containing glycolipid and an E-selectin-IgG chimera, we have demonstrated the direct binding of the L-selectin-IgG chimera to sialyl Lewis^x. This recognition was calcium dependent, and could be blocked by Mel-14 antibody but not by other antibodies. Recognition was confirmed by the ability of cells expressing the native L-selectin to adhere to immobilized sialyl Lewis^x. These data suggest that the sialyl Lewis^x oligosaccharide may form the basis of a recognition domain common to all three selectins.

A large body of data implicates a family of receptors, the selectins (lectin-EGF-complement binding-cell adhesion molecules [LEC-CAMs])¹, in the initial interactions between leukocytes and vascular endothelia leading to lymphocyte homing, platelet binding, and neutrophil extravasation (Hallman et al., 1991; Lawrence and Springer, 1991; Luscinskas et al., 1989; Watson et al., 1991). L-selectin is involved in lymphocyte homing to peripheral lymph nodes. P-selectin participates in adhesion of activated platelets. E-selectin seems to facilitate T-cell infiltration at sites of cutaneous inflammation (Picker et al., 1991; Shimizu et al., 1991). All three may be involved in neutrophil extravasation at sites of tissue damage or infection (Stoolman, 1989). The cell surface expression of these three receptors is differentially regulated, and binding of one receptor may have significant effects on the expression of other selectins and on integrin adhesion receptors (Kuijpers et al., 1991; Lo et al., 1991; Spertini et al., 1991).

The three known selectins, L-Selectin (leukocyte adhesion molecule-1 [LECAM-1], LAM-1, gp90MEL), E-Selectin (LECAM-2, endothelial-leukocyte adhesion molecule-1

[ELAM-1]), and P-Selectin (LECAM-3, GMP-140), each contain a domain with homology to calcium-dependent lectins (C-lectins), an EGF-like domain, and several complement binding protein-like (CBP) domains (Bevilacqua et al., 1989; Johnston et al., 1989; Lasky et al., 1989; Tedder et al., 1989). Identification of the C-lectin domains has led to an intense effort to define carbohydrate ligands for these glycoproteins. There is now general agreement that E-Selectin recognizes NeuNAc α 2-3 Gal β 1-4 (Fuc α 1-3) GlcNAc (sialyl-Lewis^x, or sLe^x) and related oligosaccharides (Berg et al., 1991; Lowe et al., 1990; Phillips et al., 1990; Tie-meyer et al., 1991; Tyrrell et al., 1991; Walz et al., 1990). P-Selectin has been reported to recognize the Lewis^x structure (Gal β 1-4 (Fuc α 1-3) GlcNAc) (Larsen et al., 1990) and/or sLe^x (Polley et al., 1991); although other ligands are possible (Moore et al., 1991).

Although L-selectin is probably the best studied selectin, its carbohydrate ligand has been extremely difficult to define. This is due primarily to the difficulty in obtaining significant quantities of high endothelial venule (HEVs), the tissue thought to contain most of the native ligand. Data suggest the L-selectin ligand may contain fucose, sialic acid (Imai et al., 1991; Stoolman and Rosen, 1983; True et al., 1990), and/or mannose (Yednock et al., 1987) with possible additional anionic character provided by sulfate or phosphate esters. Glycoprotein ligands of L-selectin (Sgp⁵⁰, Sgp⁹⁰) recently reported from mouse HEVs (Imai et al., 1991) possess many

1. *Abbreviations used in this paper:* CBP, complement binding protein; ELAM-1, endothelial-leukocyte adhesion molecule-1; HEV, high endothelial venules; ICAM, intercellular adhesion molecule; LECAM-1, leukocyte adhesion molecule-1; LEC-CAM, lectin-EGF-complement binding-cell adhesion molecule.

of the residues expected for a native ligand (fucose, sialic acid, sulfate), although neither the structure of the carbohydrate chains, nor the exact nature of the residues required for recognition have been defined as yet. Here we report that L-Selectin, like E- and P-Selectin, can recognize sLe^x and related oligosaccharides, an observation that now unifies the three selectins by ligand as well as protein structure.

Materials and Methods

Reagents

The sLe^x glycolipid, 2-6 sLe^x glycolipid and the sLe^x tetrasaccharide (see Table I) were synthesized as previously described (Kameyama et al., 1991; Tyrrell et al., 1991). The following materials were obtained from Sigma Chemical Co. (St. Louis, MO): bovine brain sulfatides, G_{M1}, G_{T1b}, mixed brain gangliosides, fucoidan, heparin, chondroitin sulfate, phosphatidyl serine, phosphatidyl inositol, phosphatidyl choline, *p*-nitrophenylphosphate, mannose 1-phosphate, mannose 6-phosphate, galactose 6-phosphate, and glucosamine 2,3 diphosphate. The asialo-G_{M1}, lactosylceramide, lacto-*N*-fucopentaose I glycolipid, lacto-*N*-fucopentaose II (Le^a) glycolipid, lacto-*N*-fucopentaose III (Le^b), and Gb5Cer (GalNAc α1-3 GalNAc β1-3 Gal α1-4 Gal β1-4 Glc β1- Ceramide) were obtained from Biocarb (Lund, Sweden). Sialyllactose was obtained from Oxford Glycosystems (Oxford, England). Mel-14 antibody (Gallatin et al., 1983) was purified by ammonium sulfate precipitation from culture supernatants (ATCC #HB132). Anti-ELAM antibody (BBA2 and anti-intercellular adhesion molecule (ICAM) antibody (BBA4) were obtained from British Bio-technology Ltd. Murine IgG was obtained from Zymed Laboratories (South San Francisco, CA).

Selectin-IgG Chimeras

The production and characterization of L-Selectin-IgG chimera have been previously described (Watson et al., 1990). This chimera contains two complement binding domains, consistent with its natural expression (Watson et al., 1991b). Chimeras for E- and P-Selectins, containing 2 and 1 complement binding protein domains, respectively (see Fig. 1), were constructed in a similar manner, expressed in 293 cells, and purified using a protein A affinity column. E- and P-Selectins were constructed with truncated complement binding domains to standardize the size of the chimeras and to facilitate their secretion. The three chimeras run at the expected sizes of ~95 kD (E- and L-Selectins) and 93 kD (P-Selectin) on reducing SDS-PAGE. Under nonreducing conditions they show apparent molecular masses of 200 kD (E- and L-Selectins) and 190 kD (P-Selectin) (data not shown), indicating that they are dimers as predicted by the chimera construction (see Fig. 1). Column chromatography of the three selectin chimeras run in Dulbecco's PBS on Bio-Gel A 0.5 M Gel obtained from Bio-Rad Laboratories (Richmond, CA) showed similar profiles. Peaks that corresponded to expected molecular sizes of the dimeric chimeras and to aggregates of two or three chimeras were identified in all three selectins (data not shown) suggesting that what aggregation occurred was consistent among them. ELISA assays utilizing a mouse monoclonal anti-human IgG, or antibodies specific for L-Selectin (Mel-14), E-Selectin (BBA-2), or P-Selectin (AC1.2) were used to ensure that the proper chimera construct was expressed. We have previously demonstrated that the L-Selectin chi-

mera was able to block lymphocyte binding to frozen sections of peripheral lymph node high endothelial venules in the Stamper-Woodruff assay (Watson et al., 1990). Functional activity of the E- and P-Selectin IgG chimeras was demonstrated by inhibition of human umbilical vein endothelial cell/neutrophil adhesion (Bevilacqua et al., 1987) and platelet/HL-60 binding (Larsen et al., 1990), respectively (see Fig. 2). The single modification in each of these published assays was the incubation of the neutrophils or HL-60 cells with 10 mg/ml human IgG (4°C, 1 h) before the experiment to block potential interaction of the Fc receptors on these cells with the IgG portion of the chimeras.

ELISA Assays

Glycolipids dissolved in chloroform/methanol/water (4:8:3) were dried and reconstituted in 50% methanol at desired concentrations. 50 μl was added to each Pro-Bind microtiter well (Falcon) and allowed to air dry. Adsorption of sLe^x and 2-6 sLe^x glycolipids have been quantitated as previously described (Tyrrell et al., 1991) and found to be equivalent. Others (Blackburn et al., 1986) have quantitated adsorption efficiencies for a variety of additional sialic acid-containing glycolipids and found them to be nearly identical. Coated wells were washed twice with distilled water, then blocked with 5% BSA in Dulbecco's PBS containing 1 mM Ca⁺⁺ but no Mg⁺⁺ for 1 h at room temperature. Plates were then washed three times with PBS before incubation. The following were added to PBS containing 1% BSA: (a) 1:1,000 dilution of biotinylated goat F(ab') anti-human IgG Fc (Caltag, South San Francisco, CA); (b) 1:1,000 dilution of alkaline phosphatase-streptavidin (Caltag); and (c) 1 μg/ml L-Selectin, E-Selectin, P-Selectin or CD4 IgG chimera. These reagents were allowed to form a complex for 15-30 min at room temperature before addition to coated wells (50 μl/well). Inhibitors or antibodies, when used, were added to the selectin complexes 30 min before transfer of the mixtures to the coated microtiter wells. The selectin complexes were incubated on the glycolipid coated surfaces at 37°C for 45 min, and then washed three times with PBS followed by three washes with distilled water. 50 μl/well of *p*-nitrophenylphosphate (1 mg/ml) in 1 M diethanolamine with 0.01% MgCl₂, pH 9.8, was added and the color developed in the dark for 30-60 min. Plates were read at 405 nm in a microtiter plate reader (Molecular Devices Corporation, Menlo Park, CA).

Cell Adhesion Assays

EL-4 cells (ATCC #TIB39) were grown in suspension culture in DME (Gibco Laboratories, Grand Island, NY) with 10% FCS, 1% glutamine with 50 μg/ml Gentamycin sulfate (Gibco Laboratories). These cells expressed significant levels of L-Selectin on their surfaces, as detected by fluorescence microscopy or FACS analysis using the Mel-14 antibody as the primary detection reagent (data not shown). The cells were harvested by centrifugation and washed in PBS (calcium and magnesium free), and resuspended in DME with 25 mM Hepes and 10 mg/ml BSA. Glycolipids were adsorbed on PVC microtiter wells as described for the ELISA assay above. Cells (150,000 per well) were applied to the wells by centrifugation at 50 g for 1 min, then incubated for 1 h at 37°C. Wells were immersed in DME with 25 mM Hepes, sealed, inverted, and centrifuged to apply a 50-g detachment force for 10 min. Adherent cells were quantitated by lactate dehydrogenase activity (Brandley et al., 1987).

Results

Characterization of Selectin-IgG Chimeras

The inclusion of the hinge region of the IgG Fc portion of

Table I. Nomenclature

Name	Structure
sLe ^x glycolipid	NeuNAc α2-3 Gal β1-4 (Fuc α1-3) GlcNAc β1-3 Gal β1-4 Glc - ceramide
2-6 sLe ^x glycolipid	NeuNAc α2-6 Gal β1-4 (Fuc α1-3) GlcNAc β1-3 Gal β1-4 Glc - ceramide
sLe ^x tetra	NeuNAc α2-3 Gal β1-4 (Fuc α1-3) GlcNAc
2-6 sLe ^x tetra	NeuNAc α2-6 Gal β1-4 (Fuc α1-3) GlcNAc
sLe ^x (G1c) tetra	NeuNAc α2-3 Gal β1-4 (Fuc α1-3) Glc
PPME	polysaccharide containing mannose 6-phosphate
Fucoidan	polysaccharide containing fucose 4-sulfate
Sgp ⁵⁰	glycoprotein ligand from mouse HEV containing fucose, sialic acid, and sulfate

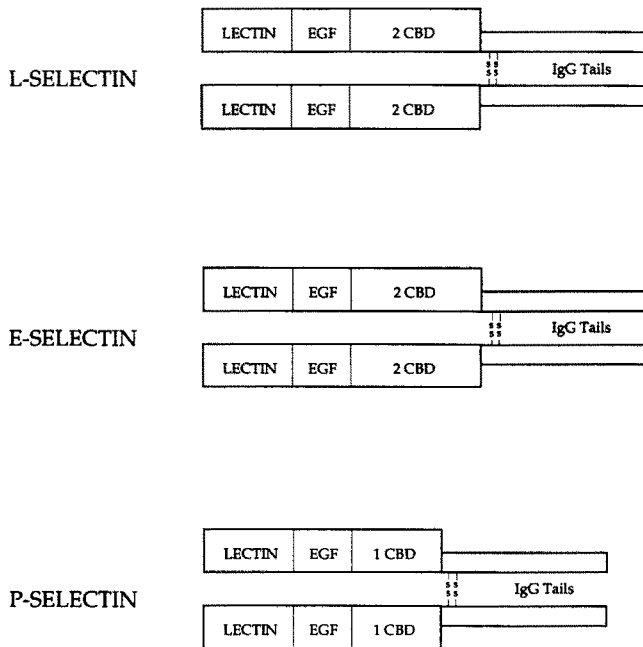

Figure 1. Selectin-immunoglobulin constant region chimeras were constructed containing the lectin, EGF-like (*EGF*) and complement binding protein-like (*CBP*) domains as previously described (Watson et al., 1990). The L- and E-selectin chimeras contained two copies of the CBP domain (truncated at amino acid residues 332 and 287, respectively), while the P-selectin chimera contained one copy of the CBP domain (truncated at amino acid residue 272). All three chimeras contained human IgG 1 from amino acid residue 234, which includes the hinge, CH2 and CH3 domains ("IgG Tails"). As illustrated, the hinge region allows for the formation of a dimeric selectin-IgG chimera. The CD4 IgG control chimera (not shown) has been previously described (Capon et al., 1989).

the chimeras used in this study produced a divalent, antibody-like construct (Fig. 1). SDS-PAGE of the chimeras revealed the expected apparent molecular weights of the monomers (reducing gels) and the dimeric construction under nonreducing conditions (data not shown). Aggregate for-

mation was consistent among all three Selectin-IgG chimeras. The integrity of the chimeras was demonstrated by recognition of both components by appropriate antibodies and by biological assay. Anti-human IgG antibody captured all three selectin chimeras as well as human IgG, whereas only the specific selectins were recognized by antibodies directed to the lectin domain of the chimeras (data not shown). L-Selectin-IgG previously had been shown to stain HEVs, and block lymphocyte binding to HEVs (Watson et al., 1990). E-Selectin-IgG inhibited neutrophil binding to activated human umbilical vein endothelial cells (Fig. 2 A) and P-Selectin-IgG inhibited HL-60 platelet interaction (Fig. 2 B).

Validation of ELISA Assays Using E- and P-Selectin-IgG Chimeras

Knowledge of carbohydrate ligands recognized by E-Selectin allowed the development of conditions for direct binding ELISA assays using the E-Selectin-IgG chimera and the sLe^x ligand. The E-Selectin chimera bound to an adsorbed glycolipid containing the sialyl-Lewis^x oligosaccharide, NeuNAc 2-3 Gal 1-4 (Fuc 1-3) GlcNAc 1-3 Gal 1-4 Glc-Ceramide (sLe^x glycolipid) (Fig. 3), a known ligand for this receptor (Tyrrell et al., 1991). This binding was concentration dependent with respect to the adsorbed glycolipid (Fig. 3) and the amount of E-Selectin chimera used (data not shown). A glycolipid similar to sLe^x glycolipid but with the NeuNAc linked 2-6 instead of 2-3 (2-6 sLe^x glycolipid), previously shown not to be recognized by E-Selectin (Tyrrell et al., 1991), was used as a negative control. Binding of E-Selectin to sLe^x glycolipid in this ELISA was calcium dependent, and could be blocked by antibodies against E-Selectin (but not control antibodies) as well as by the sLe^x tetrasaccharide (Table II) (Tyrrell et al., 1991). Since the detection system in the ELISA was based on the human IgG Fc region common to all of the selectin chimeras, this assay was extended for use with the P-Selectin IgG chimera. P-Selectin also bound to sLe^x glycolipid in a dose-dependent fashion (Fig. 3), although there was more variability in level of binding between experiments than seen for either

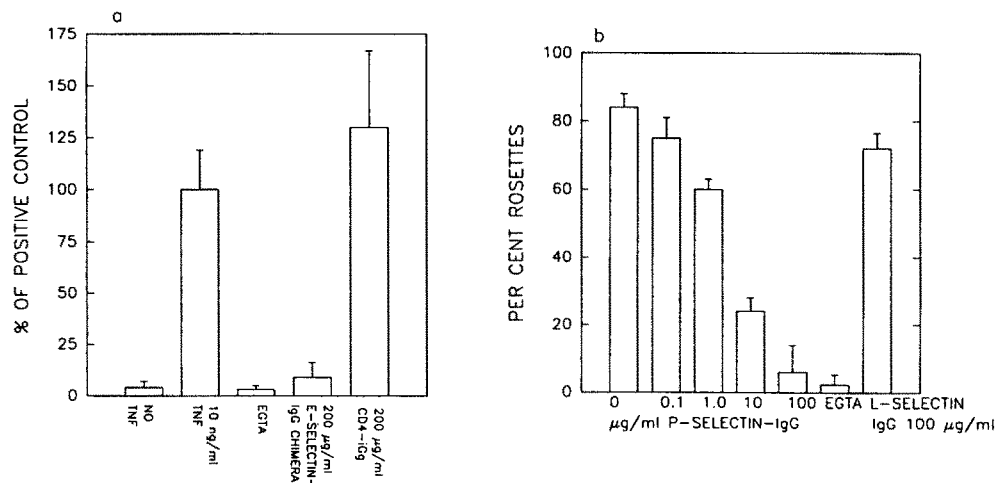

Figure 2. (a) E-selectin-IgG inhibited neutrophil binding to activated HUVEC. HUVECs were stimulated with 10 ng/ml TNF as previously described. Neutrophils, which had been preincubated with human IgG (10 mg/ml) to block potential interaction with Fc receptors on the IgG portion of the chimera, were tested for their ability to bind to the stimulated HUVEC in the presence of either E-selectin-IgG or CD4-IgG (200 µg/ml). (b) P-selectin-IgG chimera inhibited the adhesion of HL-60 cells and platelets. HL-60 cells were preincubated with

human IgG, as described above. The cells were then added to platelets, with or without addition of the P-selectin-IgG chimera, and the percentage of HL-60 cells in rosettes was determined.

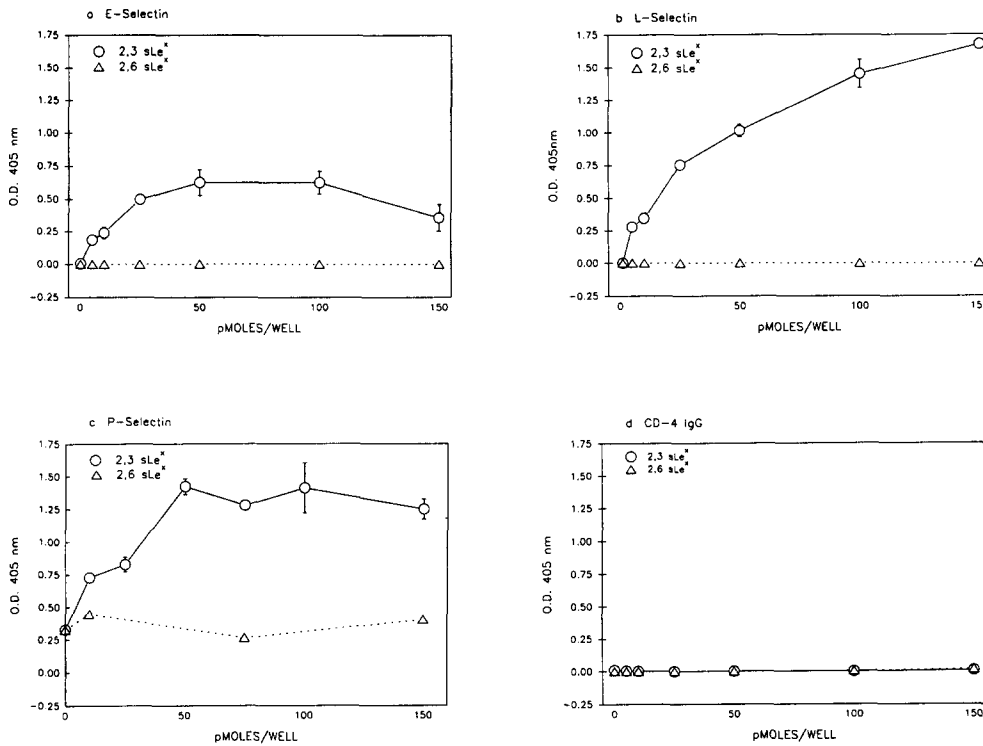

Figure 3. The ability of E-selectin-IgG, L-selectin-IgG, P-selectin-IgG, or CD4-IgG to bind directly to various concentrations of immobilized sLe^x was determined. 2,3 sLe^x (○) or 2,6 sLe^x (△) glycolipids were adsorbed in increasing concentrations to microtiter wells as described in Materials and Methods. The wells were blocked with 5% BSA. Then, either E-selectin-IgG (a), L-selectin-IgG (b), P-selectin-IgG (c), or CD4-IgG (d) 1 μg/ml in the detection system (see Materials and Methods) were incubated (50 μl/well) at 37°C for 45 min. After thorough washing, *p*-nitrophenylphosphate (1 mg/ml) was added and chromagen development was read as OD at 405 nm. Results are presented as the mean ($n = 3$) ± SEM.

Table II. Inhibitors of L-selectin and E-selectin Chimera ELISA Assays

A							
Inhibitor	Conc.	E-Selectin		L-Selectin		P-Selectin	
		% Bound	SEM (n)	% Bound	SEM (n)	% Bound	SEM
EDTA	2 mM	3.2	0.3	1.9	0.4	9.0	0.3
Mel-14 Ab	1 μg/ml	109.6	2.9	52.3	2.2	68.3	2.1
	10 μg/ml	100.0	4.3	4.6	0.1	66.7	0.7
Anti-E Ab	1 μg/ml	4.3	0.2	96.2	1.8	85.7	1.5
Anti-P Ab	1 μg/ml	94.1	2.5	91.6	2.1	13	1.2
B							
PPME	200 μg/ml	95.7	2.1 (6)	33.4	10.1 (12)		
Mannose 1-phosphate	50 mM	61.1	7.7 (3)	58.4	11.8 (3)		
	25 mM	92.1	8.1 (3)	67.1	3.8 (3)		
	12 mM	110.8	10.9 (4)	76.5	9.5 (3)		
	5 mM	60.7		68.1	5.1 (5)		
Mannose 6-phosphate	50 mM	not done		19.9	2.4 (3)		
	25 mM	52.2	7.4 (3)	32.4	6.8 (3)		
	12 mM	66.1	7.7 (3)	48.2	5.9 (3)		
	5 mM	66.95	10.4 (3)	62.8	5.2 (7)		
sLe ^x tetra	5 mM	13.8	4.0 (3)	51.5	10.7 (3)		
	2 mM	36.6	5.9 (12)	68.7	10.9 (3)		
	1 mM	48.9	3.3 (6)	121.0	34.0 (3)		
sLex(Glc) tetra	2 mM	7.2	0.2 (1)	87.9	5.8 (1)		
	0.5 mM	30.6	2.6 (1)	93.8	1.8 (1)		

2,3 sLe^x glycolipid was adsorbed to microtiter wells at 25 pmol/well and blocked with 5% BSA in PBS containing 1 mM Ca. (A) EDTA (2 mM) was added to E-selectin-IgG, L-selectin-IgG, or P-selectin-IgG in detection system as described in Materials and Methods. Antibodies to E-selectin-IgG or P-selectin-IgG (1 μg/ml) or to L-selectin-IgG (1 or 10 μg/ml) were incubated with each selectin-IgG chimera for 30 minutes at 37°C. (B) Either E-selectin-IgG or L-selectin-IgG (1 μg/ml) in detection system as described in Materials and Methods were added to potential inhibitors to final concentrations listed below, and allowed to react for 30 min at room temperature. (A and B) These reactants were added to triplicate wells at 50 μl/well and incubated at 37°C for 45 min. After thorough washing, *p*-nitrophenylphosphate was added, (1 mg/ml), and binding was measured by means of color formation read as OD at 405 nm. Inhibitors of E-selectin and L-selectin-IgG chimera binding to sLe(x) glycolipid are expressed as percent of maximum binding in the presence of no inhibitor. Maximum binding ranged from 0.500 to 2.500 OD units. Potential inhibitors found to be inactive include 3-sialyllactose (5 mM), 6-sialyllactose (5 mM), glucose 6-phosphate (5 mM), galactose 6-phosphate (5 mM), and glucosamine 2,3 disulfate (5 mM).

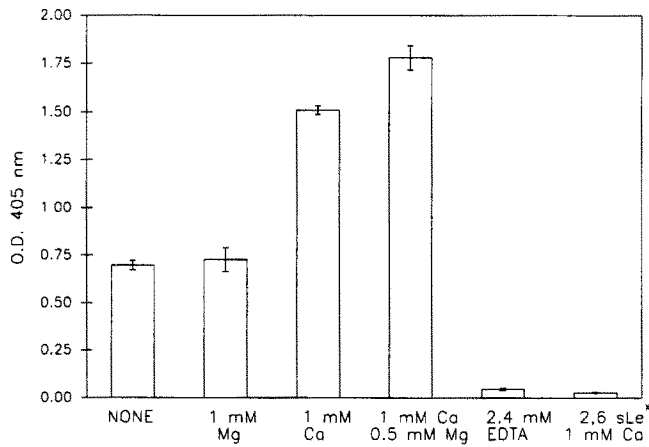

Figure 4. Binding of L-selectin-IgG to 2,3 sLe^x glycolipid was calcium dependent. 2,3 sLe^x glycolipid was adsorbed to microtiter wells as previously described. L-selectin-IgG (1 μg/ml), 1% BSA, and 1:1,000 dilutions of biotin-labeled goat F(ab')₂ and alkaline phosphate-labeled streptavidin were added to PBS with either no divalent cations, 1 mM Mg, 1 mM Ca, 1 mM Ca and 0.5 mM Mg, or 2.5 mM EDTA and allowed to react for 30 min. 50 μl of each solution was added to triplicate wells and incubated at 37°C for 45 min. Control wells adsorbed with 2,6 sLe^x glycolipid were tested with L-selectin plus other reactions in PBS with 1 mM Ca. Binding was determined by color development of the substrate, *p*-nitrophenylphosphate, read as OD at 405 nm. Results are presented as the mean ± SEM.

E- or L-Selectin. This binding was also calcium-dependent, and blocked by the appropriate antibody (Table II).

Direct Binding of the L-Selectin IgG Chimera to sLe^x Glycolipid

Using the ELISA assay characterized above, recognition by the L-Selectin IgG chimera of the sLe^x glycolipid, but not to the 2-6 sLe^x glycolipid, could be demonstrated. This binding was concentration dependent with respect to the adsorbed glycolipid (Fig. 3) and the amount of L-Selectin chimera used (data not shown). The binding of L-Selectin to the sLe^x glycolipid was calcium dependent (Fig. 4), and could be blocked by the Mel-14 antibody but not by IgG or control antibodies (Table II). L-Selectin did not bind to 2-6 sLe^x glycolipid or many other charged or uncharged glycolipids, but did bind to some degree to phosphatidyl serine and sulfatides (Fig. 5). However, binding to these additional lipids was not calcium dependent (Fig. 5).

Soluble Inhibitors

A variety of carbohydrates previously reported to interact with L-Selectin were used as potential soluble inhibitors of L-Selectin binding to sLe^x glycolipid (Table II). As expected from previous studies, (Mai et al., 1990; Yednock et al., 1987) PPME, the core phosphomannan polysaccharide from *Hansenula holstii*, was able to inhibit L-Selectin adhesion in a concentration-dependent manner. PPME had little effect on E-Selectin binding to sLe^x glycolipid (Table II). The sLe^x tetrasaccharide competed for binding with both selectins, although it competed more effectively and more consistently for binding to E-Selectin. Notably a similar tetrasaccharide with a reducing-end glucose instead of an

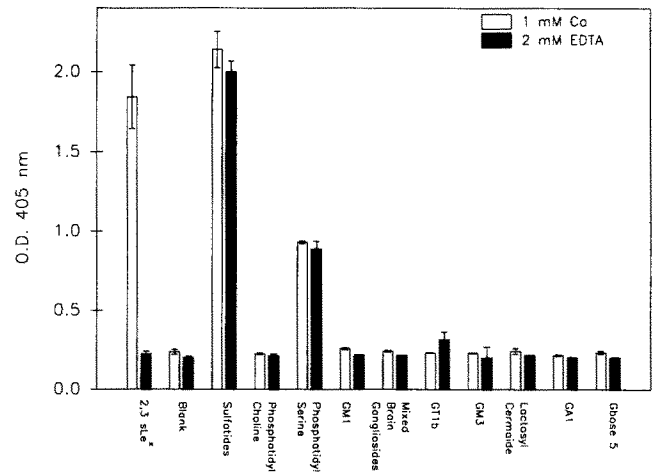

Figure 5. A panel of charged and uncharged glycolipids were tested as possible ligands for L-selectin-IgG. 2,3 sLe^x glycolipid and the other glycolipids were adsorbed to microtiter wells (100 pmol/well) as previously described. One set of control wells, in which no lipid was adsorbed, was tested for nonspecific binding of the reactants. L-selectin-IgG, biotin-labeled goat F(ab')₂ anti-human IgG (Fc) and alkaline phosphatase-labeled streptavidin, as described (Materials and Methods), were added to PBS containing 1% BSA and either 1 mM Ca or 2 mM EDTA. Results are presented as the mean (n = 3) ± SEM. Other lipids and glycolipids tested and found to be inactive included lacto-N-fucopentaose I glycolipid, lacto-N-fucopentaose II (Le^a) glycolipid, lacto-N-fucopentaose III (Le^x) glycolipid, phosphatidyl inositol, cholesterol, and cholesterol 3-sulfate.

N-acetylglucosamine, sLe^x(Glc), was a potent inhibitor of E-Selectin, but had little effect on L-Selectin. At high concentrations (>10 mM) mannose 6-phosphate substantially blocked recognition of sLe^x glycolipid by both L-Selectin and E-Selectin while mannose 1-phosphate was less effective. Other compounds, including fucosyllactose and sialyllactose, did not inhibit binding of any selectin to sLe^x. Fucoidan also had little effect on E-Selectin binding, but initially appeared to have variable effects on L-Selectin, at times seeming to stimulate rather than inhibit binding. Wells pretreated with fucoidan and washed before addition of receptor supported L-Selectin adhesion, whether or not sLe^x glycolipid was present (data not shown). This suggested that the fucoidan adhered to the ProBind wells and may have mediated L-Selectin (but not E-Selectin) binding on its own. Further investigation showed that the L-Selectin-fucoidan interaction was not affected by the addition of 2 mM EDTA, and was only partially reduced in the presence of higher EDTA concentrations. Thus the interaction appeared to be largely calcium independent.

Cell Adhesion Assays

A cell-based adhesion assay was used to help verify the biological relevance of the interaction between L-Selectin and sLe^x. EL-4 cells expressing high levels of L-Selectin on their surfaces (Nottenburg et al., 1990), were able to adhere to sLe^x glycolipid in a calcium-dependent manner (Fig. 6); this adhesion was blocked by the Mel-14 antibody but not by control antibody. These data demonstrate that the native

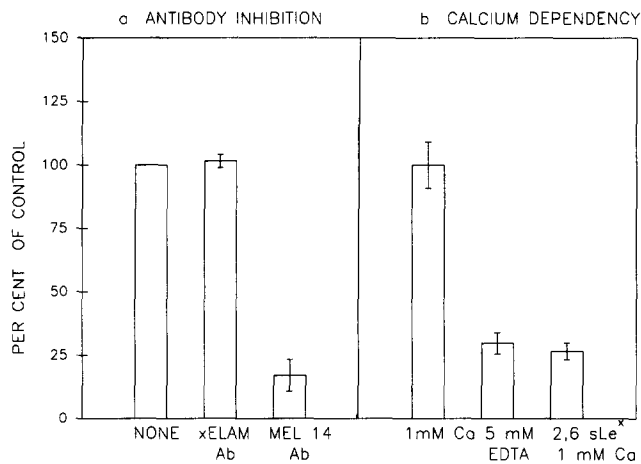

Figure 6. Binding of EL-4 cells, which express L-selectin on their cell surfaces, to immobilized 2,3 sLe^x (a) was inhibited by Mel 14 Ab and (b) was calcium dependent. Microtiter wells were adsorbed with 2,3 or 2,6 sLe^x glycolipid, as described previously (Materials and Methods). EL-4 cells were harvested and washed in PBS with no Ca or Mg, and suspended in DME with 25 mM Hepes and 10 mg/ml BSA. (a) Antibodies were added to final concentration of 10 μg/ml and incubated at room temperature for 30 min. Cells were applied to the wells by centrifugation at 50 g for 1 min and then incubated at 25°C for 1 h. Wells were immersed in DME with 25 mM Hepes, sealed, inverted, and centrifuged at 50 g for 10 min to remove unbound cells. (b) In a second experiment, the cells were prepared as above and 5 mM EDTA was added to washed, resuspended cells which were applied to triplicate wells. Control cells without EDTA were applied to triplicate wells coated with either 2,3- or 2,6 sLe^x. The assay was continued as described above. Results are presented as the mean ($n = 3$) ± SEM.

L-Selectin, inserted in a cell membrane, can recognize sLe^x, and supports the view that binding seen with the genetically engineered L-Selectin-IgG is not an artifact due to the chimera construction.

Discussion

This report provides evidence indicating that sLe^x and related oligosaccharides are recognized by all three known selectins. This is an interesting finding, considering that these proteins have very similar structural motifs, possess a high degree of sequence homology (particularly in the lectin domain), and have genes that reside on the same region of the same chromosome (Collins et al., 1991; Ord et al., 1990). A considerable amount of attention has been focused on defining carbohydrate ligands which interact with the lectin domains of the three selectins (Brandley et al., 1990). E-Selectin recognizes NeuNAc α2-3 Gal β1-4 (Fuc α1-3) GlcNAc (sLe^x) and related oligosaccharides (Berg et al., 1991a; Lowe et al., 1990; Phillips et al., 1990; Tiemeyer et al., 1991; Tyrrell et al., 1991; Walz et al., 1990). There is still a debate concerning the carbohydrate ligand(s) for P-Selectin, but sLe^x is again one of the proposed active structures (Polley et al., 1991). The data suggest that sLe^x may form a core recognition sequence for this family of receptors.

The L-Selectin IgG chimera used in these ELISA assays consists of the lectin, EGF, and the two CBP domains of

L-Selectin, attached to the Fc portion of human IgG. In this case, the natural L-Selectin was truncated at the transmembrane region leaving the extracellular domains of the protein intact. The E-Selectin chimera was constructed with two CBP domains to allow direct comparison with the L-Selectin chimera used in this study. Our observation that truncation of the CBP domains did not appear to alter binding by E-Selectin is in accord with that of Pigott et al. (1991). The P-Selectin chimera contained one less CBP domain, an alteration required for expression and secretion of this selectin. Previously, the L-Selectin IgG chimera has been shown to bind to peripheral node high endothelial venules, block L-Selectin-mediated lymphocyte adhesion, and recognize PPME and Sgp⁵⁰ in a calcium-dependent manner (Watson et al., 1990; Imai et al., 1991). We have shown here that L-Selectin IgG chimera recognized the sLe^x oligosaccharide epitope (Figs. 3 and 5). The divalent form of the selectin chimeras, when preincubated with the biotinylated anti-IgG antibody and the streptavidin-alkaline phosphatase, presumably form a multivalent complex. Generation of this multivalent complex appears to increase the sensitivity of this ELISA. While the absolute levels of binding may be affected by the complex formation, relative binding of any selectin-chimera complex to various glycolipids can be compared. Specificity of sLe^x binding was indicated by the fact that recognition was concentration dependent, calcium sensitive, and blocked by the appropriate antibody. Carbohydrate specificity was strongly supported by the inability of the selectin to recognize an otherwise identical glycolipid with only a different sialic acid linkage (2-6 sLe^x glycolipid). In addition, a wide variety of other glycolipids and oligosaccharides, both charged and uncharged, were unable to support L-Selectin recognition (Fig. 5, Table II). A cell adhesion assay was used to confirm the interaction of sLe^x with L-Selectin. EL-4 cells, known to possess significant levels of L-Selectin and to adhere to HEV sections in the Stamper-Woodruff assay (Nottenburg et al., 1990), also adhered to sLe^x glycolipid but not 2-6 sLe^x glycolipid. This adhesion was calcium dependent and inhibitable by the Mel-14 antibody. These data indicated that the native L-Selectin, in situ, will also recognize sLe^x.

Until recently, data concerning potential carbohydrate ligands for L-Selectin was mostly indirect, obtained using inhibition assays with high concentrations of simple sugars (Stoolman and Rosen, 1983), or direct binding assays to non-mammalian (yeast, algal) polysaccharides (Imai et al., 1990; Yednock et al., 1987). Potential glycoprotein ligands for L-Selectin have now been isolated from lymphoid tissue (addressins, Sgp⁵⁰; Berg et al., 1991a; Imai et al., 1991) which have the expected characteristics for an L-Selectin ligand, including the presence of sialic acid and fucose. Binding of these glycoproteins by L-Selectin is calcium dependent and inhibitable by PPME and appropriate antibodies. However, only extremely small quantities of these ligands have been available and this has delayed completion of the structural analysis of their carbohydrate chains. While the presence of sLe^x or close structural variants has not been demonstrated on these native ligands nor on high endothelial venules (Berg et al., 1991b), we present data here clearly demonstrating that L-Selectin can recognize sLe^x. The binding of sLe^x glycolipid by L-Selectin has many of the characteristics previously reported for L-Selectin activity (Imai et al., 1990;

Yednock et al., 1987). The sLe^x glycolipid contains fucose and sialic acid, residues implicated in L-Selectin recognition. The binding of L-Selectin to sLe^x glycolipid was calcium dependent and blocked by MEL 14 antibody and PPME. At high concentrations, mannose 6-phosphate inhibited E- and L-Selectin recognition of sLe^x glycolipid, while mannose 1-phosphate was less effective. Fucoidan and sulfatides were recognized by L-Selectin, but not by E-Selectin. However, there were some differences between the L-Selectin IgG chimera binding to sLe^x glycolipid and previously reported L-Selectin activities. In this ELISA assay, recognition of sulfatides and fucoidan was mostly calcium independent. Although these fucoidan results may seem to be in conflict with the recent observations of Kansas et al. (1991), calcium-independent adhesion of lymphocytes to fucoidan has been described previously (Brandley et al., 1987). We are unable to resolve this one difference at this time.

While it is apparent that all three selectins will bind to sLe^x glycolipid, data obtained using soluble inhibitors (Table II) indicate that there are significant differences among the receptors. The PPME interacts only with L-Selectin, while sLe^x(Glc) blocks only E-Selectin. The sLe^x tetrasaccharide is most effective at inhibition of E-Selectin binding, but does inhibit L-Selectin binding to a lesser extent. While certainly not definitive, these data suggest that each selectin may require modifications on the basic sLe^x recognition sequence for optimal affinity. The effects of modifications of sLe^x on recognition by the three selectins warrants further study.

If a single ligand can be recognized by all three selectins, how can one account for the fact that these receptors mediate physiologically relevant leukocyte adhesion under different functional conditions? Certainly differential regulation of the cell surface expression of the receptors and/or ligands could account for the specificity. In addition, at least three other hypotheses could explain selectin specificity. (a) Modifications (sulfation, acetylation, etc) of the basic sLe^x oligosaccharide structure could result in increased affinity for one selectin. (b) The scaffolding to which the oligosaccharide is attached (protein or lipid aglycone), or the oligosaccharide arrangement on the aglycone may be important to differentiate recognition among the selectins. (c) A second site on the selectins may participate in recognition of the ligand and may, at least in part, regulate specificity. Data obtained using the soluble inhibitors PPME, sLe^x, and sLex(Glc) suggest that there are differences in L-Selectin and E-Selectin binding to sLe^x glycolipid. It is very likely, then, that the sLe^x epitope (or structural analogue such as sLe^x) forms the basis of a recognition domain that can be further modified. The sLe^x epitope may provide a central theme, with each selectin preferring a variation on that theme.

The authors would like to acknowledge Dr. Mary Gamble and Tracey Gant for technical assistance.

Received for publication 25 October 1991 and in revised form 20 February 1992.

References

Berg, E. L., M. K. Robinson, O. Mansson, E. C. Butcher, and J. L. Magnani. 1991a. A carbohydrate domain common to both sialyl Le^x and sialyl Le^a is recognized by the endothelial cell leukocyte adhesion molecule ELAM-1. *J.*

- Biol. Chem.* 265:14869-14872.
- Berg, E. L., M. K. Robinson, R. A. Warnock, and E. C. Butcher. 1991b. The human peripheral lymph node vascular addressin is a ligand for LECAM-1, the peripheral lymph node homing receptor. *J. Cell Biol.* 114:343-349.
- Bevilacqua, P. P., J. S. Pober, D. L. Mendrick, R. S. Cotran, and M. A. Gimbrone, Jr. 1987. Identification of an inducible endothelial-leukocyte adhesion molecule. *Proc. Natl. Acad. Sci. USA.* 84:9238-9242.
- Bevilacqua, M. P., S. Stengelin, M. A. Gimbrone, Jr., and B. Seed. 1989. Endothelial leukocyte adhesion molecule 1: an inducible receptor for neutrophils related to complement regulatory proteins and lectins. *Science (Wash. DC).* 243:1160-1165.
- Blackburn, C. C., P. Swank-Hill, and R. L. Schnaar. 1986. Gangliosides support neural retina cell adhesion. *J. Biol. Chem.* 261:2873-2881.
- Brandley, B. K., T. S. Ross, and R. L. Schnaar. 1987. Multiple carbohydrate receptors on lymphocytes revealed by adhesion to immobilized polysaccharides. *J. Cell Biol.* 105:991-997.
- Brandley, B. K., S. J. Swiedler, and P. W. Robbins. 1990. Carbohydrate ligands of the LEC cell adhesion molecules. *Cell.* 63:861-863.
- Capon, D., S. Chamow, J. Mordenti, S. Marsters, T. Gregory, H. Mitsuya, R. Byrn, C. Lucas, F. Wurm, J. Grooman, S. Broder, and D. Smith. 1989. Designing CD4 immunoadhesins for AIDS therapy. *Nature (Lond.).* 337:525-631.
- Collins, T., A. Williams, G. I. Johnston, J. Kim, R. Eddy, T. Shows, M. A. Gimbrone, Jr., and M. P. Bevilacqua. 1991. Structure and chromosomal location of the gene for endothelial-leukocyte adhesion molecule 1. *J. Biol. Chem.* 266:2466-2473.
- Gallatin, W. M., I. L. Weissman, and E. C. Butcher. 1983. A cell-surface molecule involved in organ-specific homing of lymphocytes. *Nature (Lond.).* 304:30-34.
- Hallman, R., M. A. Jutila, C. W. Smith, D. C. Anderson, T. K. Kishimoto, and E. C. Butcher. 1991. The peripheral lymph node homing receptor LECAM-1 is involved in CD18-independent adhesion of human neutrophils to endothelium. *Biochem. Biophys. Res. Commun.* 174:236-243.
- Imai, Y., D. D. True, M. S. Singer, and S. D. Rosen. 1990. Direct demonstration of the lectin activity of gp90^{MEL}, a lymphocyte homing receptor. *J. Cell Biol.* 111:1225-1232.
- Imai, Y., M. S. Singer, C. Fennie, L. A. Lasky, and S. D. Rosen. 1991. Identification of a carbohydrate-based endothelial ligand for a lymphocyte homing receptor. *J. Cell Biol.* 113:1213-1221.
- Johnston, G. I., R. G. Cook, and R. P. McEver. 1989. Cloning of GMP-140, a granule membrane protein of platelets and endothelium: sequence similarity to proteins involved in cell adhesion and inflammation. *Cell.* 56:1033-1044.
- Kameyama, A., H. Ishida, M. Kiso, and A. Hasegawa. 1991. Total synthesis of sialyl Lewis X. *Carbohydrate Res.* 209:c1-c4.
- Kansas, G. S., O. Spertini, L. M. Stoolman, and T. F. Tedder. 1991. Molecular mapping of functional domains of the leukocyte receptor for endothelium, LAM-1. *J. Cell Biol.* 114:351-358.
- Kuijpers, T. W., B. C. Hakker, M. Hoogerwerf, J. F. M. Leeuwenberg, and D. Roos. 1991. Role of endothelial leukocyte adhesion molecule-1 and platelet activating factor in neutrophil adherence to IL-1 prestimulated endothelial cells. *J. Immunol.* 147:1369-1376.
- Larsen, E., T. Palabrica, S. Sajer, G. E. Gilbert, D. D. Wagner, B. C. Furie, and B. Furie. 1990. PADGEM-dependent adhesion of platelets to monocytes and neutrophils is mediated by a lineage-specific carbohydrate, LNF III (CD15). *Cell.* 63:467-474.
- Lasky, L. A., M. S. Singer, T. A. Yednock, D. Dowbenko, C. Fennie, H. Rodriguez, T. Nguyen, S. Stachel, and S. D. Rosen. 1989. Cloning of a lymphocyte homing receptor reveals a lectin domain. *Cell.* 56:1045-1055.
- Lawrence, M. B., and T. A. Springer. 1991. Leukocytes roll on a selectin at physiologic flow rates: distinction from and prerequisite for adhesion through integrins. *Cell.* 65:859-873.
- Leffler, H., and S. H. Barondes. 1986. Specificity of binding of three soluble rat lung lectins to substituted and unsubstituted mammalian β -galactosides. *J. Biol. Chem.* 261:10119-10126.
- Lo, S. K., S. Lee, R. A. Ramos, R. Lobb, M. Rosa, G. Chi-Rossa, and S. D. Wright. 1991. Endothelial-leukocyte adhesion molecule 1 stimulates the adhesive activity of leukocyte integrin CR3 (CD11/bCD18, Mac-1 α MP2) on human neutrophils. *J. Exp. Med.* 173:1493-1500.
- Lowe, J. B., L. M. Stoolman, R. P. Nair, R. D. Larsen, T. L. Berhend, and R. M. Marks. 1990. ELAM-1-dependent cell adhesion to vascular endothelium determined by a transfected human fucosyltransferase cDNA. *Cell.* 63:475-484.
- Luscinskas, F. W., A. F. Brock, M. A. Arnaout, and M. A. Gimbrone, Jr. 1989. Endothelial-leukocyte adhesion molecule-1 dependent and leukocyte (CD11/CD18)-dependent mechanisms contribute to polymorphonuclear leukocyte adhesion to cytokine-activated human vascular endothelium. *J. Immunol.* 142:2257-2263.
- Moore, K. L., A. Varki, and R. P. McEver. 1991. GMP-140 binds to a glycoprotein receptor on human neutrophils: evidence for a lectin-like interaction. *J. Cell Biol.* 112:491-499.
- Nottenburg, C., W. M. Gallatin, and T. St. John. 1990. Lymphocyte HEV adhesion variants differ in the expression of multiple gene sequences. *Gene.* 95:279-284.
- Ord, D. C., T. J. Ernst, L.-J. Zhou, A. Rambaldi, O. Spertini, J. Griffin, and

- T. F. Tedder. 1990. Structure of the gene encoding the human leukocyte adhesion molecule-1 (TQ1, Leu-8) of lymphocytes and neutrophils. *J. Biol. Chem.* 265:7760-7767.
- Phillips, M. L., E. Nudelman, F. C. A. Gaeta, M. Perez, A. K. Singhal, S. Hakomori, and J. C. Paulson. 1990. ELAM-1 mediates cell adhesion by recognition of a carbohydrate ligand, sialyl-Le^x. *Science (Wash. DC)*. 250:1130-1132.
- Picker, L. J., T. K. Kishimoto, C. W. Smith, R. A. Warnock, and E. C. Butcher. 1991. ELAM-1 is an adhesion molecule for skin-homing T cells. *Nature (Lond.)*. 349:796-799.
- Pigott, R., L. A. Needham, R. M. Edwards, C. Walker, and C. Power. 1991. Structural and functional studies of the endothelial activation antigen endothelial leucocyte adhesion molecule-1 using a panel of monoclonal antibodies. *J. Immunol.* 147:130-135.
- Polley, M. J., M. L. Phillips, E. Wayner, E. Nudelman, A. K. Singhal, S. Hakomori, and J. C. Paulson. 1991. CD62 and endothelial cell-leukocyte adhesion molecule 1 (ELAM-1) recognize the same carbohydrate ligand, sialyl-Lewis x. *Proc. Natl. Acad. Sci. USA.* 88:6224-6228.
- Shimizu, Y., S. Shaw, N. Graber, T. V. Gopal, K. J. Horgan, G. A. Van Seventer and W. Newman. 1991. Activation-independent binding of human memory T cells to adhesion molecule ELAM-1. *Nature (Lond.)*. 349:799-802.
- Spertini, O., G. S. Kansas, J. M. Munro, J. D. Griffin and T. F. Tedder. 1991. Regulation of leukocyte migration by activation of the leukocyte adhesion molecule-1 (LAM-1) selectin. *Nature (Lond.)*. 349:691-694.
- Stoolman, L. M. 1989. Adhesion molecules controlling lymphocyte migration. *Cell.* 56:907-910.
- Stoolman, L. M., and S. D. Rosen. 1983. Possible role for cell-surface carbohydrate-binding molecules in lymphocyte recirculation. *J. Cell Biol.* 96:722-729.
- Tedder, T. F., G. M. Isaacs, T. J. Ernst, G. D. Demetri, D. A. Adler, and C. M. Distèche. 1989. Isolation and chromosomal localization of cDNAs encoding a novel lymphocyte cell surface molecule, LAM-1. *J. Exp. Med.* 170:123-133.
- Tiemeyer, M., S. J. Swiedler, M. Ishihara, M. Moreland, H. Schweingruber, P. Hirtzer, and B. K. Brandley. 1991. Carbohydrate ligands for endothelial-leukocyte adhesion molecule 1. *Proc. Natl. Acad. Sci. USA.* 88:1138-1142.
- True, D. D., M. S. Singer, L. A. Lasky, and S. D. Rosen. 1990. Requirement for sialic acid on the endothelial ligand of a lymphocyte homing receptor. *J. Cell Biol.* 111:2757-2764.
- Tyrrell, D., P. James, N. Rao, C. Foxall, S. Abbas, F. Dasgupta, M. Nashed, A. Hasegawa, M. Kiso, D. Asa, J. Kidd, and B. K. Brandley. 1991. Structural requirements for the carbohydrate ligand of E-Selectin. *Proc. Natl. Acad. Sci. USA.* 88:10372-10376.
- Walz, G., A. Aruffo, W. Kolanus, M. Bevilacqua, and B. Seed. 1990. Recognition by ELAM-1 of the sialyl-Le^x determinant on myeloid and tumor cells. *Science (Wash. DC)*. 250:1132-1135.
- Watson, S. R., Y. Imai, C. Fennie, J. S. Geoffrey, S. D. Rosen, and L. A. Lasky. 1990. A homing receptor IgG chimera as a probe for adhesive ligands of lymph node high endothelial venules. *J. Cell Biol.* 110:2221-2229.
- Watson, S. R., C. Fennie, and L. A. Lasky. 1991a. Neutrophil influx into an inflammatory site inhibited by a soluble homing receptor-IgG chimera. *Nature (Lond.)*. 349:164-167.
- Watson, S. R., Y. Imai, C. Fennie, J. Geoffrey, M. Singer, S. D. Rosen, and L. A. Lasky. 1991b. The complement binding-like domains of the murine homing receptor facilitate lectin activity. *J. Cell Biol.* 115:235-243.
- Yednock, T. A., L. M. Stoolman, and S. D. Rosen. 1987. Phosphomannosyl-derivatized beads detect a receptor involved in lymphocyte homing. *J. Cell Biol.* 104:713-723.