

Safe and Effective Fluid Management by Automated Gravitation during Hysteroscopy

Tomaz Tomazevic, MD, PhD, Luka Savnik, MSc, Miran Dintinjana, MD
Martina Ribic-Pucelj, MD, PhD, Marija Pompe-Tansek, MD, Andrej Vogler, MD, PhD, Darinka Kos, MD

ABSTRACT

Objective: The automated gravitational Vario Flow system with weighing-based electronic fluid deficit indicator was used in order to reduce the risk of fluid intravasation during continuous flow hysteroscopic procedures. Early experiences are reported.

Methods: Between August 1996 and July 1997, the Vario Flow with fluid deficit indicator and alarm system was used in 203 hysteroscopic operations. Between January 1994 and August 1996 the Vario Flow without fluid deficit indicator was used in 240 hysteroscopic operations. In all, there were 443 hysteroscopic operations: 301 metroplasties, 20 endometrial ablations, 10 cases of lysis of synechiae, 58 myomectomies and 54 polypectomies. The data on fluid deficit before and after the introduction of the electronic fluid deficit indicator were similar.

Results: Fluid deficit indicator was proved highly efficient in 203 operations. It provided the information on fluid deficit at any moment during hysteroscopic operations. Besides intrauterine pressure, the actual fluid deficit has become one of the leading parameters during our continuous flow hysteroscopic procedures.

Conclusion: We therefore conclude that by using an automated gravitational system with fluid deficit indicator and alarm system, the safety for patients during hysteroscopic procedures has been increased.

Key Words: Hysteroscopy, Fluid management, Gravitation, Safety.

INTRODUCTION

The automated gravitational Vario Flow system was constructed in order to reduce the risk of fluid intravasation while using gravity for uterine distention during continuous flow hysteroscopic procedures.¹ It provides linear regulation, definition and measurement of intrauterine pressure by simply pressing the pedal and changing the height difference between the fluid level and the level of the hysteroscope. Fluid outflow to the receptacle is also driven by gravity. The weighing-based electronic fluid deficit indicator was built into the second version of the Vario Flow system¹ in order to provide the utmost control of fluid dynamics and to further improve safety for the patient.²⁻⁵ After promising clinical testing in 1995¹ and after resolving some essential technical problems (1995/96) in August 1996 it was introduced into daily clinical work. Schematic and the photograph of the second version of Vario Flow are presented in the **Figures 1 and 2**. Situated on the stand of the Vario Flow system, the electronic weighing system indicates the weight of the whole system, including inflow bag and outflow receptacle and shows the overall fluid deficit (in ml) on the display. The scales on the display determine the weight of the whole system as zero reference weight at the beginning of the procedure and as real weight during the procedure. If the liquid that was discharged from the endoscope is not collected in the fluid receptacle, the weight of the system is reduced and the difference between the two values is shown on the display as liquid loss (**Figure 3**). If the loss exceeds a preset critical amount of liquid a warning signal sounds. Pause function is used for changing the empty water bag and the full fluid receptacle during the procedure (**Figure 4**). Clinical experiences by using Vario Flow with fluid deficit indicator are reported.

PATIENTS AND METHODS

Between August 1996 and July 1997, Vario Flow with the fluid deficit indicator and the alarm system was used in 203 hysteroscopic operations. Between January 1994 and August 1996 the volumetric method was used to control fluid deficit in 240 hysteroscopic operations. In all, there were 443 hysteroscopic operations: 301 metroplasties, 20 endometrial ablations, 10 cases of lysis of synechiae, 58 myomectomies and 54 polypectomies. Most women

Address reprint request to: Professor Tomaz Tomazevic, University Medical Center, Department of Gynecology and Obstetrics, Slajmerjeva 3, 1000 Ljubljana, Slovenia.

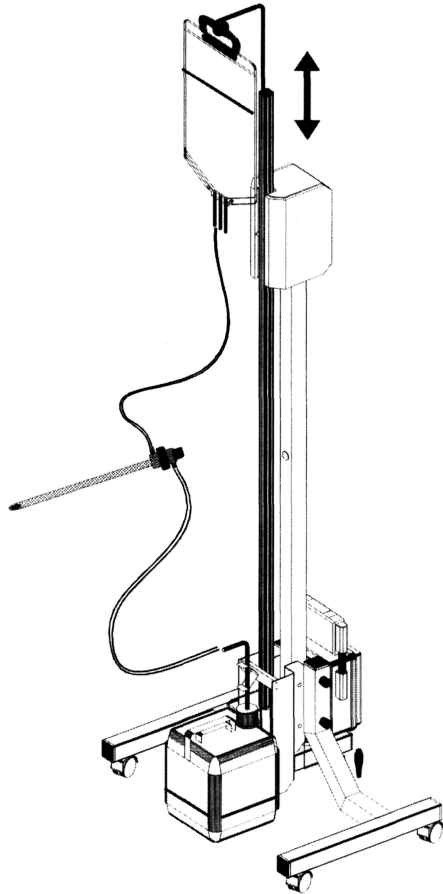

Figure 1. Schematic of the Vario Flow with fluid deficit indicator.

received danazol 400 mg for a short period (one to three weeks) starting on day 1 of the menstrual cycle since the day of operation for endometrial preparation. Vaginal ultrasound and diagnostic continuous flow hysteroscopy were performed for preoperative diagnosis. Dextrose 5% was the distending medium. Vario Flow was used as a distending system (**Figures 1 and 2**). In normal circumstances the fluid filled bag of the Vario Flow was raised between 1 and 1.4 m (76-100 mmHg) above the patient according to individual conditions permitting good visualization and considering the danger of fluid intravasation. Intermediate 1.4-1.5 m (100-110 mmHg) and extreme height ranges 1.5-1.9 m (110-140 mmHg) were exceptionally used—according to individual surgical needs. Volumetric and weighing method were used for final fluid deficit evaluation. Retrospective comparison of data on final fluid deficit in 240 patients before, and in 203 patients after, the introduction of fluid deficit indicator was performed by using t test for two samples assuming equal variances.

RESULTS

In our patients accurate visualization and good control of fluid dynamics were always obtained during operative hysteroscopies. All operations were performed in one attempt. Before the introduction of the fluid deficit indicator there were two uterine perforations. No immediate or late general complications occurred. The data on fluid deficit before and after the introduction of the fluid deficit indicator are presented in **Table 1**.

The mean fluid value in group 2 was insignificantly lower compared to the mean fluid deficit value in group 1. Zero hypothesis was accepted ($P < 0.01$).

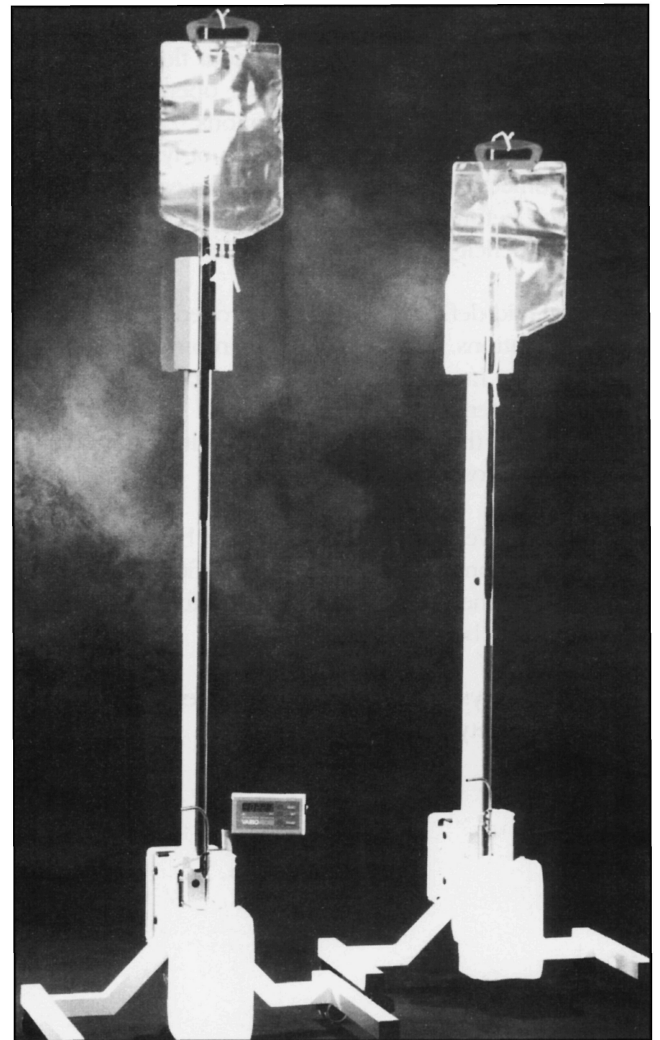

Figure 2. The Vario Flow with or without fluid deficit indicator.

DISCUSSION

Fluid deficit is the difference between the volume of fluid infused and the measured volume recovered. This is an important parameter during continuous flow hysteroscopic procedures and is affected by factors such as the accuracy and completeness of fluid collection, the quantity of fluid escaping around the hysteroscope, out of the fallopian tubes and the fluid intravasation. Large quantities of fluid can be forced into patient's circulation with alarming rapidity. This is a serious and potentially fatal problem of which every hysteroscopic surgeon should be aware.⁶ An irrigating fluid deficit of between 1000 and 1500 ml has been generally accepted as the upper limit for a safe procedure.^{7,8}

The gravity continuous flow system without regulation produces an intracavitary pressure of 110 mmHg when the bag is about 150 cm above the patient, and the pressure of this magnitude can force fluid into the circulation and produce the problems of the fluid overload. On the other hand, lowering of this height reduces the intracavitary pressure which may also be associated with adverse features.⁶

Control of intracavitary pressure with the Endomat system did however reduce the risk of fluid intravasation by two thirds.⁶ Garry has shown that replacing a simple roller pump infusion system with a pressure controlled pump infusion system reduced the fluid absorption by 85%.⁹ Different pressure pumps have been constructed to promote patient safety and to facilitate tracking inflow and outflow volumes.^{10,11}

These features as well as the cost problems have been considered while constructing the Vario Flow system.¹² As recommended by Indman,² it provides a rapid flow until the designated intrauterine pressure is reached and then auto-

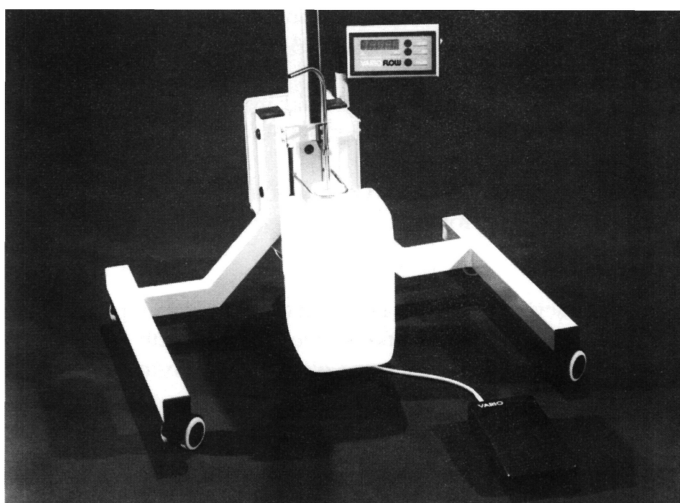

Figure 3. Receptacle with the display.

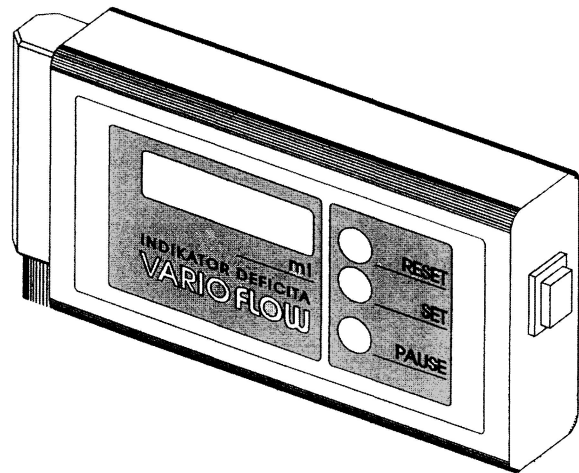

Figure 4. Display of fluid deficit indicator.

matically shuts off simply by adjusting the elevation of the fluid-filled bag. Providing a careful control of intrauterine pressure,¹ the automated gravitational system combines the advantages of a low cost gravity system with the advantages of careful intrauterine pressure and outflow control of more sophisticated systems. Similar to the Dolphin hysteroscopic management system,¹⁰ the Vario Flow also provides a stable non pulsatile uterine distention.¹ Despite careful control of intracavitary pressure, avoidance of going too deeply into the myometrium and early detection of arterial bleeding, the important fluid deficit may occur at any time in a previously quite normal case, and fluid deficit may move from zero to several litres in a few minutes.⁹ Often the operator is unaware of impending disaster because of inability to monitor accurately the amount of fluid instilled and volume recovered from the patient.¹⁰ Because fluid overload is the major complication related to the uterine distention, the ideal system for delivery of low viscosity media would also measure the inflow and outflow of the fluid and sound an alarm if an excess of fluid deficit is detected.¹ It is this feature, and not the intrauterine pressure, that should guide the conduct of any case.^{4,5}

By combining the Vario Flow with the fluid deficit indicator and alarm system we tried to reach this goal and to further reduce the risk of uncontrolled fluid intravasation. It is interesting to note that at the same time two similar systems to control fluid deficit have been independently developed and simultaneously presented at the AAGL congress in Orlando, 1995.^{13,14}

According to early experiences in our series of patients, the real weight based fluid deficit indicator was proven highly efficient in providing information on the fluid deficit at any moment during the procedure as well as the actual information on the final fluid deficit. The reassuring or alarm-

Table 1.
Results of final fluid deficit control before (group 1)
and after the introduction of fluid deficit indicator (group 2)

	Number of observations	Average value	Standard deviation	Min	Max
Fluid deficit-ml (group 1)	240	440	310	100	1500
Fluid deficit-ml (group 2)	203	375	369	40	2000

* In 45 operations of group 1 the fluid deficit was >450 ml.
** In 31 operations of group 2 the fluid deficit was >450 ml.

ing information about fluid deficit at any moment during hysteroscopic procedures was especially important in operations of long duration and in operations where higher intrauterine pressure ranges were needed for uterine distention. Except in cases with abundant spillage, the fluid intravasation was easily controlled. In these cases, any of commercially available drape systems work well if properly applied to the patient perineum and connected to return canister.¹⁰ Thus, in our hands, the real time fluid deficit has become one of the leading parameters of fluid dynamics during our hysteroscopic procedures. There were no significant differences between the data on the final fluid deficit in both series of patients. This is not surprising because the least possible pressure providing good vision was used in both groups of patients. Compared to volumetric assessment, monitoring the real weight on the display seems to be an easier way of following fluid deficit in hysteroscopic surgery.

CONCLUSION

The automated gravitational continuous flow system with fluid deficit indicator can be used effectively and safely for uterine distention during hysteroscopic procedures.

References:

1. Tomazevic T, Savnik L, Dintinjana M. Vario Flow system - an automated gravitational system for delivery of low viscosity media during operative continuous flow hysteroscopy. *J Am Assoc Gynecol Laparoscopists*. 1996;3:617-621.
2. Indman PD. Instruments and video cameras for operative hysteroscopy. *Clin Obstet Gynecol*. 1992;35:211-224.
3. Shirk GJ, Kaigh J. The use of low-viscosity fluids for hysteroscopy. *J Am Assoc Gynecol Laparoscopists*. 1994;2:11-21.

4. Loffer FD. Complications from uterine distention during hysteroscopy. In Corfman RS, Diamond MP, DeCherney A, eds. *Complications of Laparoscopy and Hysteroscopy*. Oxford, London, Edinburgh, Melbourne, Paris, Berlin, Vienna: Blackwell Scientific Publications; 1993:177-186.

5. Loffer FD. The need to monitor intrauterine pressure - myth or necessity. *J Am Assoc Gynecol Laparoscopists*. 1994;2:1-2.

6. Hamou J, Fryman R, McLucas B, et al. A uterine distention system to prevent fluid intravasation during hysteroscopic surgery. *Gynecol Endosc*. 1996;5:131-136.

7. Witz CA, Silverberg KM, Burns WN, Schenken RS, Olive DL. Complications associated with absorption of hysteroscopic fluid media. *Fertil Steril*. 1993;60:745-756.

8. Barisic D, Wamsteker K, Strelec M, et al. The effect of sorbitol-mannitol absorption on sodium concentration during hysteroscopic surgery. *Gynecol Endosc*. 1996;5:323-327.

9. Garry R, Mooney P, Hashman F, et al. A uterine distention system to prevent fluid absorption during Nd Yag laser endometrial ablation. *Gynecol Endosc*. 1992;1:23-27.

10. Corson SL. Hysteroscopic fluid management. *J Am Assoc Gynecol Laparoscopists*. 1997;4:375-379.

11. Shirk GJ, Gimpelson RJ. Control of intrauterine pressure during operative hysteroscopy. *J Am Assoc Gynecol Laparoscopists*. 1994;1:229-233.

12. Tomazevic T, Savnik L, Dintinjana M, et al. Attempt to reduce the costs of irrigation in endoscopic surgery. 12th Congress of European Association of Gynaecologists and Obstetricians, June 1997, Dublin, Ireland.

13. Tomazevic T, Savnik L, Dintinjana M. Modified gravitational Vario-Flow system for uterine distention in hysteroscopic surgery. *J Am Assoc Gynecol Laparoscopists*. 1995;2:(Suppl)S79.

14. Vancaille TG, Brooks PG, Serden SP, Engel T, Neuwirth RS, Drogemueller W, Hulka T. A new instrument to monitor fluids during operative hysteroscopy. *J Am Assoc Gynecol Laparoscopists*. 1995;2:(Suppl) S79-S80.

Presented at 26th Annual Meeting of the American Association of Gynecologic Laparoscopists, Seattle, Washington, September 23-27, 1997.

Disclosure statement: From the Department of Obstetrics and Gynecology, University Medical Center, Ljubljana, Slovenia (Drs Tomazevic, Dintinjana, Ribic-Pucelj, Vogler, Pompe-Tansek and Kos); and independent researcher, Ministry of Science and Technology of Slovenia, Ljubljana Slovenia (Mr. Savnik)

Mr. Savnik patented the Vario Flow system at the Office for Intellectual Property of Slovenia. He and doctor Tomazevic are registered as innovators. The idea of fluid deficit indication was patented with the first version of Vario Flow. The technical solution of fluid deficit indication was patented separately at the Office for Intellectual Property of Slovenia. Mr. Savnik is registered as innovator. The system has only been submitted to research and no financial interest has been involved whatsoever. Mr. Savnik covered the investment. Pelta Industrial Design and Consulting, Ljubljana, Slovenia, is ready to participate in producing and distributing the system.

The study was supported by the Ministry of Science and Technology of Slovenia, Ljubljana Slovenia.