



Published in final edited form as:

Sens Biosensing Res. 2014 August ; 1: 15–20. doi:10.1016/j.sbsr.2014.07.001.

Automated-immunosensor with centrifugal fluid valves for salivary cortisol measurement

Masaki Yamaguchi^{a,*}, Hiroki Katagata^a, Yuki Tezuka^a, Daisuke Niwa^b, and Vivek Shetty^c

^aBiomedical Engineering & Robotics Laboratory, Graduate School of Engineering, Iwate University, 4-3-5 Ueda, Morioka 020-8551, Japan

^bNano Bionics R&D Center, Research and Development Headquarters, Rohm Co., Ltd., 21 Saiin Mizosaki-cho, Ukyo-ku, Kyoto 615-8585, Japan

^cSection of Oral and Maxillofacial Surgery, UCLA School of Dentistry, University of California, 10833 Le Conte Avenue, Los Angeles, CA 90095-1668, USA

Abstract

Point-of-care measurement of the stress hormone cortisol will greatly facilitate the timely diagnosis and management of stress-related disorders. We describe an automated salivary cortisol immunosensor, incorporating centrifugal fluid valves and a disposable disc-chip that allows for truncated reporting of cortisol levels (<15 min). The performance characteristics of the immunosensor are optimized through select blocking agents to prevent the non-specific adsorption of proteins; immunoglobulin G (IgG) polymer for the pad and milk protein for the reservoirs and the flow channels. Incorporated centrifugal fluid valves allow for rapid and repeat washings to remove impurities from the saliva samples. An optical reader and laptop computer automate the immunoassay processes and provide easily accessible digital readouts of salivary cortisol measurements. Linear regression analysis of the calibration curve for the cortisol immunosensor showed 0.92 of coefficient of multiple determination, R^2 , and 38.7% of coefficient of variation, CV, for a range of salivary cortisol concentrations between 0.4 and 11.3 ng/mL. The receiver operating characteristic (ROC) curve analysis of human saliva samples indicate potential utility for discriminating stress disorders and underscore potential application of the biosensor in stress disorders. The performance of our salivary cortisol immunosensor approaches laboratory based tests and allows noninvasive, quantitative, and automated analysis of human salivary cortisol levels with reporting times compatible with point-of-care applications.

Keywords

Immunosensor; Centrifugal fluid valve; Automation; Cortisol; Saliva

This is an open access article under the CC BY-NC-SA license.

*Corresponding author. Tel./fax: +81 19 621 6349. masakiy@iwate-u.ac.jp (M. Yamaguchi). URL: <http://www.mech.iwate-u.ac.jp/~yamaguchi/> (M. Yamaguchi).

Conflict of interest: The authors declare they have no conflicts of interest.

1. Introduction

The intersection of the growing body of knowledge about mental health bioindicators with advances in proteomic technologies presents great potential in the early detection, diagnosis and management of a range of stress-related disorders. Of particular interest is the stress hormone cortisol which reflects the underlying neuroendocrine response to stressors and is commonly used as marker of stress reactivity [7,13]. On exposure to a stressor, the body's hypothalamic-pituitary-adrenal (HPA) axis responds by stimulating the production and secretion of cortisol from the adrenal glands. Consequently, cortisol is considered to be a useful measure of the HPA axis adaptation to stress and disease [12]. Altered cortisol levels have been linked to a range of stress-related disorders including depression [2], post-traumatic stress disorder [19], irritable bowel syndrome [6] and increased susceptibility to infections [22].

Although blood is the most commonly used biofluid for biomarker detection and measurement, saliva presents a very compelling alternate when it comes to cortisol estimation. For one, salivary cortisol correlates well with free and biologically-active cortisol in the blood (correlation coefficient, $R = 0.81-0.97$, [25,11]. Furthermore, the levels of the free cortisol in saliva are independent of transport mechanisms, flow rates or salivary enzymes [12]. The simple and noninvasive nature of saliva collection offers multiple advantages. Unlike blood, saliva collections are readily acceptable to patients and do not provoke the needle-induced anxiety or distress that can artificially alter stress marker levels. Collections do not require trained healthcare professionals and can be accomplished by patients in naturalistic settings. Because saliva is produced continuously and does not clot, it can be sampled repeatedly at short intervals nor does it require special collection and processing equipment. All these qualities render saliva the preferred biofluid for assessing cortisol levels as a reflection of the neuroendocrine response to stressors.

Actualizing the potential of salivary cortisol in the prevention and management of stress-related disorders requires corresponding developments in bioanalytical technologies to enable rapid analysis and results reporting. Immediate access to a patient's salivary cortisol levels would empower clinicians to make timely and appropriate decisions at the "point-of-care" and enable patient-centered healthcare. To address the need for near real-time results, various investigators have advanced a range of bioanalytical platforms and strategies for rapid cortisol analysis; immunosensors based on piezoelectric elements [5], labeled conjugates [8,16], ultrasound [9], colloidal gold conjugates [15], gold nanowires [14], immune-chromatography [28], graphite electrodes [10], micro-electrodes [4], carbon nanotubes [23], electrochemical impedance spectroscopy [24], and chemiluminescence [20]. Each of these approaches is involved and includes multiple sample processing steps such as passing the biofluid between reservoirs to achieve a micro total analysis system (μ TAS) such a "lab-on-a-chip" or using repeated washing processes to remove impurities (e.g., proteins, other steroid hormones) from the sample so as to improve sensitivity and eliminate cross-reactivity. Previously, we had described a microfluidic device with a fluid control system incorporating a valve utilizing direct electro-wetting [17,18,27]. However, the multiple washing processes involved were time consuming and the flow speed constraints limited the practical utility of the system for point-of-care measurement of salivary cortisol levels. To

overcome the limitations, we redesigned the immunosensor platform to integrate centrifugal fluid valves that reduce the washing cycles required for processing the saliva sample. The biosensor assembly comprises of a disposable disc-chip incorporating centrifugal fluid valves and a corresponding portable optical reader. To begin with, we optimized the performance of the disc-chip by evaluating the effects of different surface pre-treatments. Subsequently, we evaluated the performance characteristics of the optimized immunosensor using saliva samples as well as cortisol standards. Finally, we investigated the utility of the salivary cortisol immunosensor for discriminating mental health states.

2. Materials and methods

2.1. Chemicals

A monoclonal anti-cortisol antibody (10R-C145A, host: Mouse, Cosmo Bio Co., Ltd., Japan) was used for the immunoassay. An alkaline phosphatase-labeled anti-cortisol antibody (ALP-labeled antibody) conjugate was synthesized using an alkaline phosphatase labeling kit (Kit-NH2, Wako Pure Chemical Industries, Ltd., Japan). Cortisol-3-bovine serum albumin (Cortisol-3-CMO-BSA, Cosmo Bio Co., Ltd., Japan) was immobilized on a polystyrene pad (MS-92302, Sumitomo Bakelite Co., Ltd., Japan). A chemiluminescent substrate (chemiluminescent AP microwell, wavelength: 540 nm, BioFX Laboratories Inc., MD) was used for the ALP, and a phosphate buffer solution (PBS; pH 7.3, 1 mM, Dulbecco A, Oxoid Ltd., UK) was used as a washing buffer for a reaction reservoir. A bovine serum albumin (BSA; Cas no. 9048-46-8, Wako Pure Chemical Industries, Ltd., Japan), a PBS (pH 7.3, 1 mM), and a surfactant (Tween 20, Cas no. 9005-64-5, Sigma-Aldrich Co. LLC., MO) were used to synthesize a blocking agent, BSA-PBS-T. The BSA-PBS-T, a milk protein (UK-B80, DS Pharma Biomedical Co., Ltd., Japan), and an IgG polymer (MAB-IgG/Fab(polymer), SQ Poly MAB 33, Roche Diagnostics GmbH, Germany) were used as blocking agents. Salivary cortisol levels were measured using a cortisol enzyme-linked immunosorbent assay (ELISA) kit (1-3002, monoclonal antibody to cortisol, 450 nm measurement wavelength, Salimetrics LLC, State College, PA). A cortisol standard solution in the ELISA kit was used to determine the calibration curve.

2.2. Centrifugal immunosensor

The disc-chip with a diameter of 120 mm was fabricated using an acrylic resin and an incorporated centrifugal fluid valve provided the fluid control mechanism (Fig. 1). The disposable disc-chip comprised of the following surface elements: a buffer reservoir (1455 mm³ volume, 2.5 mm depth), an injection reservoir (35.6 mm³ volume, 1.5 mm depth), a substrate reservoir (35.6 mm³ volume, 1.5 mm depth), a reaction reservoir (32.0 mm³ volume, 1.0 mm depth), and a waste fluid reservoir (556.9 mm³ volume, 2.5 mm depth), all of which were interconnected by miniature flow channels. The flow channels also functioned as valves, and the disc-chip has two different types, labeled A and B. A polystyrene pad integrated into the disc-chip was sealed with a transparent upper sealing layer (P96T01S, polyethylene terephthalate, Stem Co., Japan). The pad with cortisol-3-BSA was placed in the reaction reservoir. The upper layer contained an inlet for the buffer as well as an inlet for the sample and conjugate. Additionally, there was an inlet for the substrate and an air hole.

Fig. 2A describes the mode of operation for the centrifugal fluid valves which control the flow of the biofluid. Fig. 2B shows the principles of the immunoreaction underlying the molecular recognition of cortisol. The automated analytical process is accomplished through the following steps:

- i.** 10 μL of whole saliva sample and 10 μL of conjugate solution, including the ALP-labeled antibody conjugate, are dropped simultaneously into the injection reservoir through the inlet in the upper layer and allowed to react for 1 min to initiate the immunoreaction.
- ii.** Immediately afterwards, the disc-chip rotates at 800 rpm for 8 s to blend the solution and propel it through valve A (0.6 mm width, 0.8 mm depth, and 3 mm length). This step ends with the mixed sample transferring from the injection reservoir to the reaction reservoir.
- iii.** Once in the reaction reservoir, a competitive reaction takes place between the cortisol in the saliva sample and the cortisol-3-BSA on the pad for the duration of 1 min.
- iv.** Subsequently, the disc-chip rotates at 4000 rpm for 15 s, transferring the sample from the reaction reservoir through valve B (0.1 mm width, 0.03 mm depth, and 4 mm length) into the waste fluid reservoir.
- v.** Next, a washing buffer of 30 μL PBS is introduced into the buffer reservoir through the corresponding inlet. The disc-chip rotates again at 800 rpm for 2 s to force the washing buffer through valve A. Next, the disc-chip is rotated again at a higher 4000 rpm for 15 s to force the washing buffer through valve B. Consequently, any unreacted materials are removed from the reaction reservoir.
- vi.** Next, 30 μL of the chemiluminescent substrate is dropped into the substrate reservoir through the corresponding inlet, and the disc-chip is rotated once more at 800 rpm for 5 s. The substrate is hydrolyzed by the ALP immobilized on the pad and the resultant intensity is measured afterwards using an optical reader.

The salivary cortisol immunosensor system comprises of the disposable disc-chip with pad, a portable optical reader equipped with an amplifier (H8258, wavelength: 185-680 nm, Hamamatsu Photonics K.K., Japan), a stepping motor with a control unit (PK525HPMA, 0.36° step angle, Oriental Motor Co., Ltd., Japan), and a laptop computer (FMVLCE70B, Fujitsu Ltd., Japan, Fig. 3A and B) that controls the component processes. The assembled unit is cube-shaped with an edge length of 190 mm. The disposable disc-chips are easily exchanged by removing a simple fixing screw.

Fig. 3C summarizes the procedure for using the salivary cortisol immunosensor. Sampling kits consisting of a polypropylene cup ($14 \times 17 \times 40.3 \text{ mm}^3$) and a collection swab (sterilized dental cotton, 8 mm diameter \times 12.5 mm length) are used to collect the saliva samples. Saliva is allowed to collect on the floor of the mouth and the collection swab is placed under the tongue and allowed to saturate for 1 min. A 10 μL of the collected saliva sample is then transferred with a pipette into the injection reservoir along with 10 μL of conjugate. The analytical process is initiated by touching the start button on the data

acquisition program on the laptop. Once the automated sample processing and analytic steps are completed, the intensity of the substrate is measured by the optical reader and the salivary cortisol level automatically estimated from the resultant intensity using a calibration curve input into the laptop memory. Finally, the quantified salivary cortisol level is indicated on the laptop display.

2.3. Pre-treatment of disk-chip for the immunosensor

Optimization of the analytical platform was carried out by experimentally investigating the effects of various surface pre-treatment methods. First, the disc-chips were washed to remove the releasing agent used in injection molding of the discs. Next, a water repellent treatment agent (FS-1060TH-0.5, Fluorotechnology, Japan) was applied to the reservoirs and the flow channels (Fig. 4). Then, the effects of three different blocking agents, BSA-PBS-T (B), milk protein (M), and IgG polymer (I), were analyzed. Each was applied to both the pad and the disc-chip. The concentrations of the blocking agents applied to the disc-chip were 20 mg/mL, 4 mg/mL and 40 μ g/mL for B, M and I, respectively. The concentrations applied to the pads were 2.5 times those applied to the disc-chips.

The contact angles of the three blocking agents on the plate were measured using μ L of distilled water on an acrylic resin made from the same material as the disc-chips. A microscope (VH-E500, Keyence Co., Japan) and image-analysis software (Image J, Open source) were used to measure the contact angles. At the same time, the intensities of the optical reader were measured for each pre-treatment condition using standard cortisol solutions with concentrations of 1 and 3 ng/mL.

2.4. Calibration curve

The calibration curves for the salivary cortisol immunosensor were established using cortisol standards as well as native human saliva. The set of cortisol standards ranged from 1 to 10 ng/mL. The whole saliva samples were obtained from 10 consenting, healthy male subjects (mean \pm standard deviation (SD): 22.6 \pm 1.3 yr) using collection procedures approved by the Institutional Review Board. The salivary cortisol levels were measured using cortisol ELISA kits and a plate reader (ARVO MX; Perkin Elmer Life Science, Boston, MA) and set of human saliva samples between 0.4 and 11.3 ng/mL was used to establish calibration curves for the salivary cortisol immunosensor.

2.5. ROC analysis of salivary cortisol immunosensor

To evaluate the analytical performance of the salivary cortisol immunosensor, saliva samples were collected in the morning and the afternoon from 10 male subjects and the samples were divided into two groups based on psychometric assessment of psychological stress (high stress and low stress). Analysis of each group of samples was repeated three times. In order to verify the immunosensor's capability to potentially screen for traumatic stress, the preliminary threshold level of cortisol can be set to 2 ng/mL (2 ng/mL = 5.52 nmol/l, [3,19,21,26]). ROC curves were generated to verify the discriminatory power of the salivary cortisol level. The areas under these curves (AUC) were calculated to provide an overall summary of the diagnostic accuracy of the salivary cortisol levels with the diagnostic

capability classified into three levels; poor when $0.50 < AUC < 0.69$, good when $0.70 < AUC < 0.89$, and excellent when $0.90 < AUC < 1$.

2.6. Statistical analysis

All the analyses were performed with the Statistical Package for the Social Sciences (SPSS) version 20.0 (SPSS Inc, Chicago, IL). Unless otherwise stated, all data are expressed as the mean \pm SD.

3. Results

3.1. Pre-treatment of disc-chip for the immunosensor

The contact angles of the three blocking agents I, M, and B were 67.7° , 55.3° , and 26.0° , respectively (Table 1). The change in contact angle of the blocking agents, I, M, and B, from untreated surfaces were $+1.9^\circ$, -10.5° , and -39.8° , respectively. The water-repellency of the blocking agents increased incrementally from IgG polymer, milk protein, and BSA.

Fig. 5 shows the measured intensity results using the standard cortisol solutions. The symbols show a combination of blocking agents for the pad and the disc-chip including the reservoirs and the flow channels (Type pad-disc). The intensities of Type B-B (the pad was blocked with BSA and the disc-chip was blocked with BSA) at concentrations of 1 and 3 ng/mL were $94,732 \pm 6,738$ and $51,902 \pm 3,901$ respectively and the absolute difference, I , was 42,830. The intensities of Type I-B at concentrations of 1 and 3 ng/mL were $135,293 \pm 26,864$ and $84,146 \pm 10,601$, respectively and the absolute difference was 51,147. The intensities of Type I-M concentrations of 1 and 3 ng/mL were $124,179 \pm 18,579$ and $69,091 \pm 6,846$, respectively and the absolute difference was 55,089. The difference between the intensities for Type I-M is 1.3 times larger than that for Type B-B.

3.2. Calibration curve

Calibration curves for the salivary cortisol immunosensor were established using a set of cortisol standards ranging between 1 and 10 ng/mL. The intensity saturated 300 s after the chemiluminescent substrate was moved to the reaction reservoir, then the measurement time of the intensity was set at 300 s. This saturated value was set as the measured intensity. The difference in intensity between 1 and 10 ng/mL for Type I-M was larger than that of Types B-B and I-B. The absolute values of the detected intensities of Type I-M were $303,426 \pm 35,996$, $181,668 \pm 22,275$, and $86,157 \pm 9,847$ counts/gate when the concentrations of the standard cortisol solution were 1, 3, and 10 ng/mL, respectively (Fig. 6A).

The results of a linear regression analysis for Type I-M showed the R^2 value was 0.93; the relationship between the relative intensity, I , and the cortisol concentration, $Cort$, is given by $I = 3.09 \times 10^5 e^{-0.131Cort}$ (count/gate), and the CV is 12.3%. Thus, the detected intensity is inversely proportional to the cortisol concentration in the sample.

Repeated with the human saliva samples, the calibration curves for the salivary cortisol immunosensor showed a similar pattern (Fig. 6B). The difference in intensity between 0.4 and 11.3 ng/mL reflected that found with the cortisol standards, with Type I-M also larger than those of Types B-B and I-B. The results of a linear regression analysis for Type I-M

showed the R^2 value was 0.92; the relationship between the intensity, I , and the cortisol concentration, $Cort$, is given by $I = 3.99 \times 10^5 e^{-0.280Cort}$ (count/gate), and the CV is 38.7% over the range 0.4–11.3 ng/mL.

3.3. ROC analysis of salivary cortisol immunosensor

Fig. 7 shows the ROC curve for the salivary cortisol immunosensor when the saliva samples from the two groups of subjects. For a cortisol threshold level of 2 ng/mL, the AUC was 0.89, which manifests a good power for discriminating between subjects with and without traumatic stress symptoms.

4. Discussion

The technical improvements to the salivary cortisol immunosensor platform and the incorporation of centrifugal fluid valves eliminate many of the sample preprocessing steps associated with a previous version of our salivary cortisol immunosensor [27]. The performance of the disc-chip is optimized by choosing the appropriate blocking agents. Our evaluation of the effects of different surface pre-treatments reveal that IgG polymer for the pad and the milk protein for the reservoirs (Type I-M) and the flow channels was the most suitable combination of blocking agents to prevent the non-specific adsorption of proteins (Table 1 and Fig. 5).

The performance characteristics of the salivary cortisol immunosensor were evaluated using cortisol standard solution measured by the salivary cortisol ELISA. Comparison of the calibration curves of the salivary cortisol immunosensor with different combinations of the blocking agents, showed that the results obtained with Type I-M agent had a high correlation with those obtained by the commercial ELISA assay ($R^2 = 0.93$) and had a low CV = 12.3% for the range of cortisol standards used (1–10 ng/mL, Fig. 6A). Additionally, the dynamic range of the cortisol immunosensor (1–10 ng/mL) was broad enough to cover the range of salivary cortisol concentrations (1–8 ng/mL) reported by Aardal and Holm [1] in healthy adults (1 ng/mL = 0.1 μ g/dL = 2.76 nmol/L). Thus, the flow can be controlled just by changing the speed and number of rotations to determine which centrifugal fluid valve will open. Using a set of centrifugal fluid valves, valves A and B, enables the setting of any number of washing times to remove impurities. This mechanism allows for automated-analyses which makes possible to shorten the sampling-reporting cycle less than 15 min.

Analyzed by means of ROC curves, the salivary cortisol was shown to have good discriminating power (0.88) in discriminating of psychological stress (Fig. 7). Thus, our early testing of the salivary cortisol immunosensor using ROC curve analysis of human saliva samples indicates potential utility for near-real time assessment of stress reactions based on salivary cortisol levels.

5. Conclusions

The analytical performance of our salivary cortisol immunosensor, incorporating centrifugal fluid valves and a disposable disc-chip, allows for automated-analyses of human salivary cortisol levels within a shortened timespan (<15 min) compatible with “point-of-care”

applications. The performance characteristics of the salivary cortisol immunosensor are optimized through select blocking agents to prevent the non-specific adsorption of proteins; IgG polymer for the pad and milk protein for the reservoirs and the flow channels. Incorporated centrifugal fluid valves allow multiple washings to remove impurities. The optical reader and laptop computer automate the immunoassay processes and provide easily accessible digital readouts of salivary cortisol measurements. Our early ROC curve analysis of human saliva samples indicate good utility for discriminating stress disorders and underscore potential application for point-of-care measurement of cortisol

Acknowledgments

This research was supported in part by Grants from the 'Ministry of Education, Culture, Sports, Science, and Technology – Japan', Research Project of Recovery Supporting Technology from Disaster Stress Based on Psychosomatic Functional Evidence (P.I.-M. Yamaguchi), Japan, and Grant No. 25350517 from the 'Japan Society for the Promotion of Science – Japan', Proposal for Fluid control mechanism Based on Wettability and Establishment of Quantitative and Automated-biosensor (P.I.-M. Yamaguchi), Japan.

References

1. Aardal E, Holm AC. *Eur J Clin Chem Clin Biochem.* 1995; 33:927–932. [PubMed: 8845424]
2. Alderling M, De La Torre B, Forsell Y, Lundberg I, Sondergaard HP, Theorell T. *Psychother Psychosom.* 2008; 77:129–131. [PubMed: 18230948]
3. Anisman H, Griffiths J, Matheson K, Ravindran AV, Merali Z. *Am J Psychiatry.* 2001; 158:1509–1511. [PubMed: 11532740]
4. Arya SK, Chornokur G, Venugopal M, Bhansali S. *Analyst.* 2010; 135:1941–1946. [PubMed: 20589269]
5. Attili BS, Suleiman AA. *Anal Lett.* 1995; 28:2149–2159. [PubMed: 11541301]
6. Braak B, Klooker TK, Wouters MM, Welting O, van der Loos CM, Stanisor OL, van Diest S, van den Wijngaard RM, Boeckxstaens GE. *Am J Gastroenterol.* 2012; 107:715–726. [PubMed: 22488080]
7. Charney DS. *Am J Psychiatry.* 2004; 161:195–216. [PubMed: 14754765]
8. Cook CJ. *Nat Biotechnol.* 1997; 15:467–471. [PubMed: 9131628]
9. Cook CJ. *Physiol Behav.* 2002; 75:169–181. [PubMed: 11890965]
10. Goyal RN, Chatterjee S, Rana AR. *Talanta.* 2010; 83:149–155. [PubMed: 21035656]
11. Gozansky WS, Lynn JS, Laudenslager ML, Kohrt WM. *Clin Endocrinol.* 2005; 63:336–341.
12. Hellhammer DH, Wüst S, Kudielka BM. *Psychoneuroendocrinology.* 2009; 34:163–171. [PubMed: 19095358]
13. Kaushik A, Vasudev A, Arya SK, Pasha SK, Bhansali S. *Biosens Bioelectron.* 2014; 53:499–512. [PubMed: 24212052]
14. Kumar A, Aravamudhan S, Gordic M, Bhansali S, Mohapatra SS. *Biosens Bioelectron.* 2007; 22:2138–2144. [PubMed: 17097283]
15. Leung W, Chan P, Bosgoed F, Lehmann K, Renneberg I, Lehmann M, Renneberg R. *J Immunol Methods.* 2003; 281:109–118. [PubMed: 14580885]
16. Mirasoli M, Deo SK, Lewis JC, Roda A, Daunert S. *Anal Biochem.* 2002; 306:204–211. [PubMed: 12123657]
17. Nagai H, Narita Y, Ohtaki M, Saito K, Wakida S. *Anal Sci.* 2007; 23:975–979. [PubMed: 17690431]
18. Nashida N, Satoh W, Fukuda J, Suzuki H. *Biosens Bioelectron.* 2007; 22:3167–3173. [PubMed: 17383171]
19. Pervanidou P, Kolaitis G, Charitaki S, Lazaropoulou C, Papassotiriou I, Hindmarsh P, Bakoula C, Tsiantis J, Chrousos GP. *Biol Psychiatry.* 2007; 62:1095–1102. [PubMed: 17624319]
20. Pires NM, Dong T. *Biomed Mater Eng.* 2014; 24:15–20. [PubMed: 24211877]

21. Rohleder N, Joksimovic L, Wolf JM, Kirschbaum C. *Biol Psychiatry*. 2004; 55:745–751. [PubMed: 15039004]
22. Thornton LM, Andersen BL. *Cellscience*. 2006; 2:66–91. [PubMed: 18633462]
23. Tlili C, Myung NV, Shetty V, Mulchandani A. *Biosens Bioelectron*. 2011; 26:4382–4386. [PubMed: 21621995]
24. Venugopal M, Arya SK, Chornokur G, Bhansali S. *Sens Actuators, A*. 2011; 172:154–160.
25. Vining RF, McGinley RA, Maksvytis JJ, Ho KY. *Ann Clin Biochem*. 1983; 20:329–335. [PubMed: 6316831]
26. Wessa M, Rohleder N, Kirschbaum C, Flor H. *Psychoneuroendocrinology*. 2005; 31:209–215. [PubMed: 16154709]
27. Yamaguchi M, Matsuda Y, Sasaki S, Sasaki M, Kadoma Y, Imai Y, Niwa D, Shetty V. *Biosens Bioelectron*. 2013; 41:186–191. [PubMed: 22939507]
28. Yamaguchi M, Yoshikawa S, Tahara Y, Niwa D, Imai Y, Shetty V. Point-of-use measurement of salivary cortisol levels. *Sensors, IEEE*. 2009:343–346.

A Disc-chip

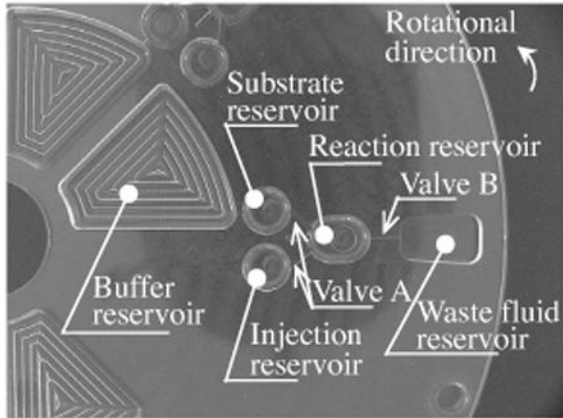

B Upper sealing

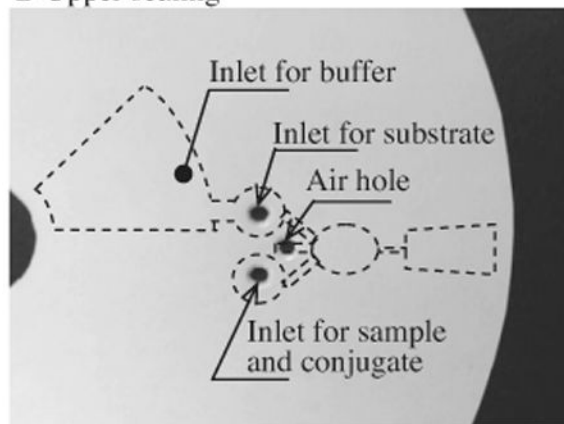

Fig. 1. External view of disc-chip incorporating centrifugal fluid valves for a salivary cortisol immunosensor.

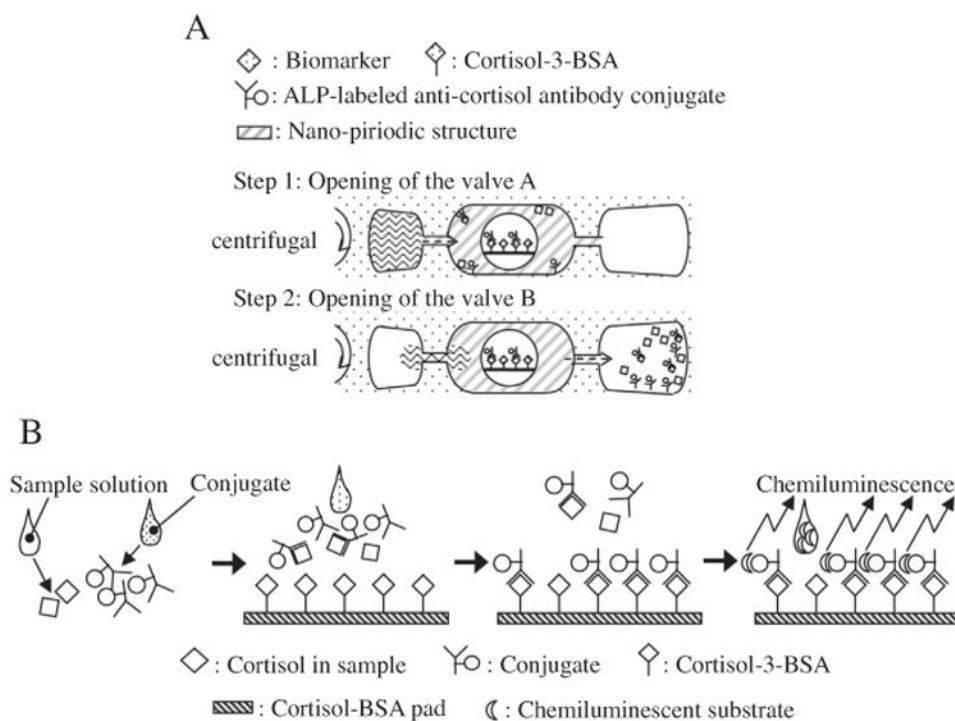

Fig. 2. (A) Set of the centrifugal fluid valves and the chemical reaction of the salivary cortisol immunosensor. (B) Immunoreaction principles underlying the molecular recognition of cortisol.

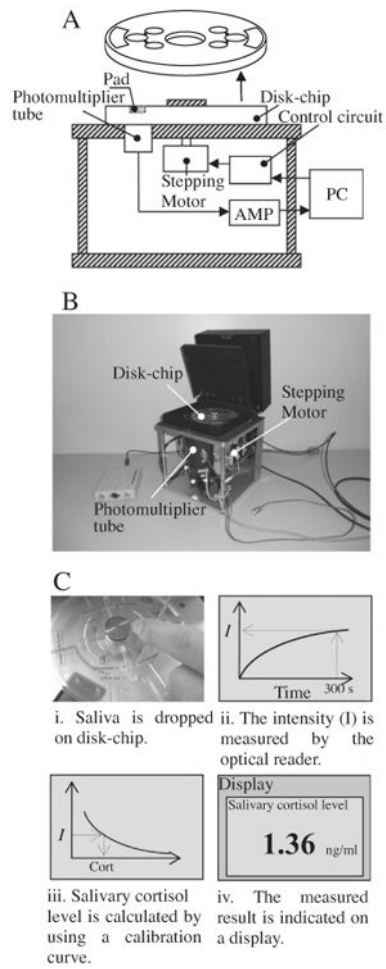

Fig. 3. (A) Block diagram of the salivary cortisol immunosensor, (B) External view of the immunosensor, and (C) Use steps for the immunosensor.

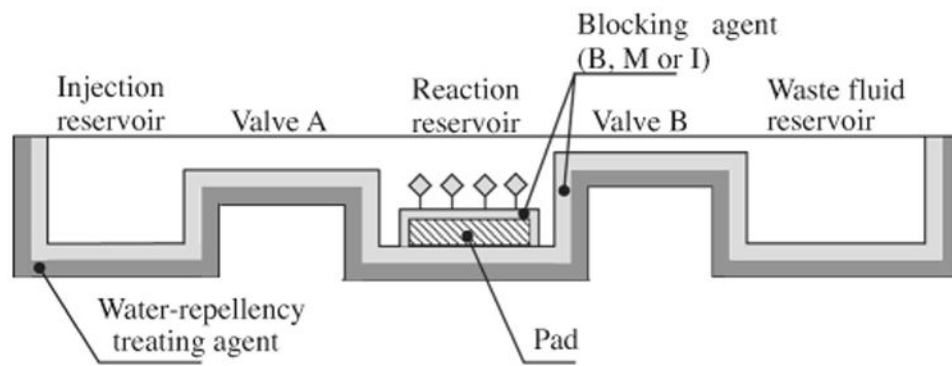

Fig. 4. Cross sectional view of the pretreated method applied to both the disc-chip and the pad (B: BSA-PBS-T, M: milk protein, I: IgG polymer).

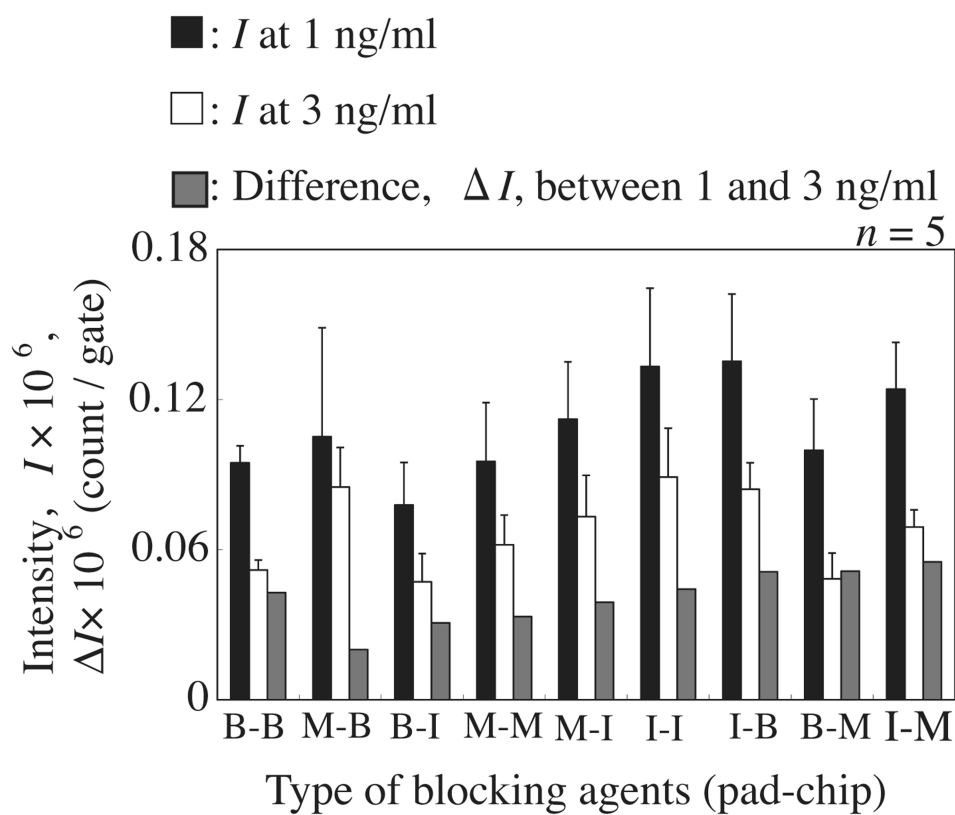

Fig. 5. Comparison of the intensities between the nine combinations of blocking agents (B: BSA-PBS-T, M: milk protein, I: IgG polymer).

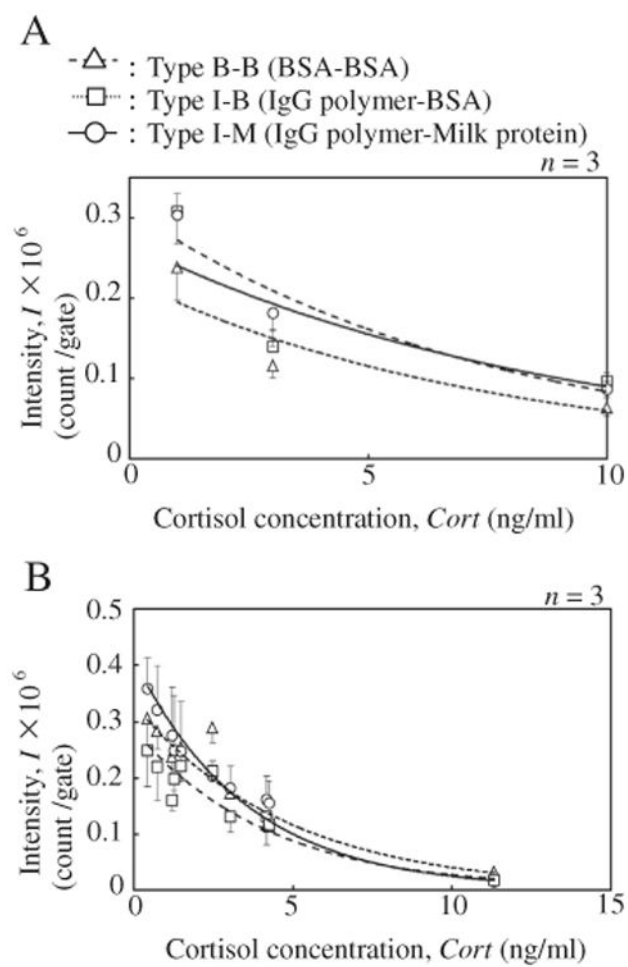

Fig. 6.
(A) Calibration curve of standard cortisol samples and (B) human saliva samples.

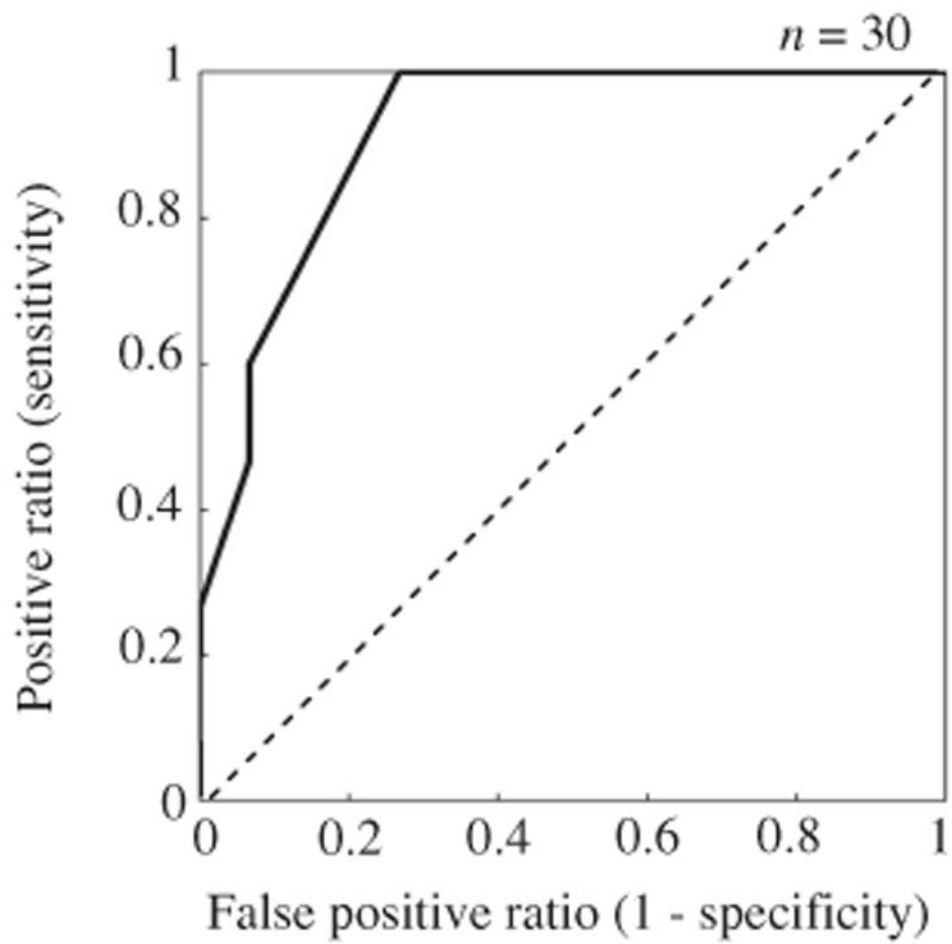
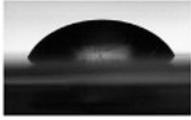

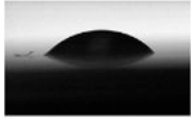
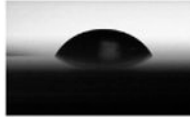

Fig. 7. ROC curve analysis using human saliva (threshold level: 2 ng/mL).

Table 1

Water-repellency of the three kinds of blocking agent.

Untreated	Blocking agent B (BSA-PBS-T)	Blocking agent M (Milk protein)	Blocking agent I (IgG polymer)
65.8°	26.0°	55.3°	67.7°
			

Author Manuscript

Author Manuscript

Author Manuscript

Author Manuscript