

# Polymerase and Exonuclease Activities in Herpes Simplex Virus Type 1 DNA Polymerase Are Not Highly Coordinated

Ashwani Kumar Vashishtha and Robert D. Kuchta\*

Department of Chemistry and Biochemistry, University of Colorado, Boulder, Colorado 80309-0215, United States

**ABSTRACT:** The herpes polymerase–processivity factor complex consists of the catalytic UL30 subunit containing both polymerase and proofreading exonuclease activities and the UL42 subunit that acts as a processivity factor. Curiously, the highly active exonuclease has minimal impact on the accumulation of mismatches generated by the polymerase activity. We utilized a series of oligonucleotides of defined sequence to define the interactions between the polymerase and exonuclease active sites. Exonuclease activity requires unwinding of two nucleotides of the duplex primer–template. Surprisingly, even though the exonuclease rate is much higher than the rate of DNA dissociation, the exonuclease degrades both single- and double-stranded DNA in a nonprocessive manner. Efficient proofreading of incorrect nucleotides incorporated by the polymerase would seem to require efficient translocation of DNA between the exonuclease and polymerase active sites. However, we found that translocation of DNA from the exonuclease to polymerase active site is remarkably inefficient. Consistent with inefficient translocation, the DNA binding sites for the exonuclease and polymerase active sites appear to be largely independent, such that the two activities appear noncoordinated. Finally, the presence or absence of UL42 did not impact the coordination of the polymerase and exonuclease activities. In addition to providing fundamental insights into how the polymerase and exonuclease function together, these activities provide a rationale for understanding why the exonuclease minimally impacts accumulation of mismatches by the purified polymerase and raise the question of how these two activities function together in vivo.

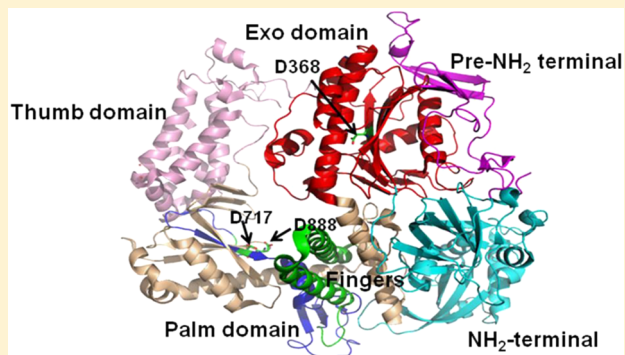

between a highly active exonuclease and minimal impact on fidelity is unclear.

Herpes viruses comprise a large family of complex DNA viruses, eight of which can infect humans.<sup>2</sup> Although generally benign, they can cause a variety of diseases including oral lesions (HSV1), genital lesions (HSV2), chicken pox and shingles (*Varicella zoster*), etc.<sup>2</sup> HSV encodes seven proteins essential for DNA replication: the heterotrimeric helicase–primase (UL5–UL8–UL52), the heterodimeric DNA polymerase–processivity factor complex (UL30–UL42), single-stranded DNA binding protein (UL29/ICP8), and an origin binding protein (UL9).<sup>3–5</sup> Although these proteins can perform the minimal set of functions needed for replication, it seems likely that other herpes and cellular proteins are involved during in vivo replication.

UL30 replicates the HSV1 DNA and contains both polymerase and 3′–5′ proofreading exonuclease activities.<sup>6</sup> Evolutionarily, the enzyme belongs to the B-family of polymerases. The polymerase activity exhibits moderate fidelity and high processivity even in the absence of its processivity factor, UL42, largely due to a very slow rate of DNA dissociation (0.07 s<sup>-1</sup>).<sup>7</sup> The exonuclease rapidly hydrolyzes double-stranded DNA ( $k_{\text{cat}} = 6 \text{ s}^{-1}$ ) although the exonuclease does not appear to greatly enhance the fidelity of DNA replication.<sup>6,7</sup> Song et al. observed similar rates of incorrect dNTP polymerization using polymerases that either contained or lacked exonuclease activity.<sup>6</sup> The cause of this disconnect

The UL42 subunit binds to and increases the processivity of UL30. Unlike processivity factors from other organisms that encircle the DNA via formation of dimers or trimers but do not directly bind the DNA,<sup>8–16</sup> UL42 directly binds the DNA and appears to function as a monomer.<sup>17</sup> UL42 also binds to DNA with high affinities for both double-stranded (2 nM) and single-stranded DNA (10 nM).<sup>18,19</sup> The relatively high affinity of UL42 for DNA and its intrinsic DNA binding activity are crucial for HSV replication, as mutations in UL42 that either increase or decrease the affinity of UL42 for DNA compromise the fidelity of herpes replication in cells.<sup>20,21</sup> However, Parris and co-workers found that UL42 affects neither the frequency with which UL30 polymerizes incorrect dNTPs nor the efficiency with which UL30's exonuclease excises nucleotides from DNA.<sup>7</sup>

Structural studies of UL30 showed that it forms the typical hand-shaped structure of a DNA polymerase with the catalytically important residues for dNTP polymerization in the palm domain.<sup>22</sup> The exonuclease resides ca. 45 Å from the polymerase active site with a small apparent hole between the

Received: July 8, 2014

Revised: November 25, 2014

Published: December 17, 2014

Table 1. DNA Substrates Used<sup>a</sup>

DNA <sub>15ss</sub>	5′-GCTCTGTTCCGGTTT
DNA <sub>15C</sub>	5′-GCTCTGTTCCGGTTT 3′-CGAGACAAGGCCAA <u>A</u> CACAAAGTAGATTAGTAC
DNA <sub>15TG</sub>	5′-GCTCTGTTCCGGTTT 3′-CGAGACAAGGCCAA <u>G</u> CACAAAGTAGATTAGTAC
DNA <sub>15GG</sub>	5′-GCTCTGTTCCGGTTG 3′-CGAGACAAGGCCAA <u>G</u> CACAAAGTAGATTAGTAC
DNA <sub>2MM</sub>	5′-GCTCTGTTCCGGTTT 3′-CGAGACAAGGCCA <u>GG</u> CACAAAGTAGATTAGTAC
DNA <sub>3MM</sub>	5′-GCTCTGTTCCGGTTT 3′-CGAGACAAGGCC <u>GGG</u> CACAAAGTAGATTAGTAC
DNA <sub>4MM</sub>	5′-GCTCTGTTCCGGTTT 3′-CGAGACAAGGCCA <u>GGG</u> CACAAAGTAGATTAGTAC
DNA <sub>35ss</sub>	5′-ATGTAATCGTATGTTTTATTTGCTCTGTTCCGGTTT
DNA <sub>53ss</sub>	5′-CATGATTAGATGAAATACAAACCGGAACAGAGCAAATAAACATACGATTACAT
DNA <sub>35C</sub>	5′-ATGTAATCGTATGTTTTATTTGCTCTGTTCCGGTTT 3′-TACATTAGCATACAAATAAACGAGACAAGGCCAA <u>A</u> CATAAAGTAGATTAGTAC
DNA <sub>35G</sub>	5′-ATGTAATCGTATGTTTTATTTGCTCTGTTCCGGTTT 3′-TACATTAGCATACAAATAAACGAGACAAGGCCAA <u>A</u> GATAAAGTAGATTAGTAC
DNA <sub>35TG</sub>	5′-ATGTAATCGTATGTTTTATTTGCTCTGTTCCGGTTT 3′-TACATTAGCATACAAATAAACGAGACAAGGCCAA <u>G</u> CATAAAGTAGATTAGTAC
DNA <sub>14G</sub>	5′-GCTCTGTTCCGGTT 3′-CGAGACAAGGCCA <u>A</u> GCACAAAGTAGATTAGTAC
DNA <sub>14A</sub>	5′-GCTCTGTTCCGGTT 3′-CGAGACAAGGCCAA <u>A</u> CACAAAGTAGATTAGTAC
DNA <sub>14C</sub>	5′-GCTCTGTTCCGGTT 3′-CGAGACAAGGCCA <u>A</u> CCACAAAGTAGATTAGTAC

<sup>a</sup>Templating bases are underlined and positions of mismatched bases are indicated in bold.

two. Although the catalytic centers of each activity are independent, no data exist with respect to DNA movement between the two sites and the coordination of the two activities.

To better understand how UL30 replicates DNA with high fidelity, we examined the interaction of the polymerase and exonuclease activities. Surprisingly, even though both activities reside on the same protein, there was remarkably little coordination between the two activities. Furthermore, several data indicate that the two activities have largely independent DNA binding domains.

## MATERIALS AND METHODS

**Chemicals.** All chemicals were of the highest grade available and were used as purchased. dNTPs were from Invitrogen, T4 polynucleotide kinase was from New England Biolabs, and [ $\gamma$ -<sup>32</sup>P]ATP was from Perkin–Elmer. T4 DNA polymerase and Klenow Fragment were obtained from New England Biolabs. Aphidicolin was from Sigma and DMSO was obtained from Fisher Scientific.

**Enzymes.** His-tagged UL30, UL30–UL42, and UL30–UL42 (exo–) were purified from SF9 insect cells infected with recombinant baculoviruses that harbor the genes encoding these proteins as described previously.<sup>23</sup> Baculovirus harboring the His-tagged UL30 gene was generously provided by Don Coen from Harvard University and amplified at the Protein Production, Monoclonal Antibody, Tissue Culture Shared

Resource at the University of Colorado–Denver Medical School.

**Oligonucleotides.** All oligonucleotides were purchased from Integrated DNA Technologies (Coralville, IA). The sequences of all primers and templates used in this study are depicted in Table 1. All primers were gel purified using 20% denaturing polyacrylamide gel electrophoresis and radiolabeled by standard procedures at the 5′-end using [ $\gamma$ -<sup>32</sup>P]ATP and T4 polynucleotide kinase.<sup>24</sup> Annealing was done by heating the primer–templates in a molar ratio of 1:1.4 to 95 °C and then slowly cooling to room temperature.

**Polymerization Assays.** All experiments were performed under conditions of excess substrate at 37 °C. Assays typically contained 1  $\mu$ M 5′-[<sup>32</sup>P] primer/template, varying concentrations of dNTPs, 50 mM Hepes (pH 7.6), 5% glycerol, 0.1 mg/mL BSA, 1 mM DTT, and 10 mM MgCl<sub>2</sub> (final concentrations). They were initiated by the addition of enzyme (typically 20 nM) and quenched at various times by adding 5 volumes of 90% formamide, 10 mM EDTA, 1× Tris–Borate–EDTA buffer, and 0.1% bromophenol blue. Samples were heated for 2 min at 90 °C and the products separated by denaturing gel electrophoresis (20% acrylamide and 8 M urea) and analyzed by phosphorimager (Molecular Dynamics). Steady-state kinetic parameters  $V_{\max}$  and  $K_m$  were obtained by plotting the rates as a function of dNTP concentration for

correct and incorrect incoming nucleotides and fitting the data to the Michaelis–Menten equation using Origin software.

**Exonuclease Assays.** All exonuclease assays were performed under steady-state conditions as described above except that dNTPs were omitted from the assays. Typically, assays contained  $1 \mu\text{M}$   $5'$ - $^{32}\text{P}$ -primer–template in the buffer described above. Reactions were initiated by adding enzyme and terminated at designated time intervals as described above. Products were separated by denaturing gel electrophoresis and analyzed as above. In a separate set of experiments, the concentration of duplex DNA ( $\text{DNA}_{15\text{C}}$ ) was varied from 400 to 2500 nM and reactions were terminated at designated time intervals as described above. Similarly, the experiment was repeated with  $\text{DNA}_{15\text{TG}}$ ,  $\text{DNA}_{2\text{MM}}$ ,  $\text{DNA}_{3\text{MM}}$ , and  $\text{DNA}_{4\text{MM}}$ . Steady-state kinetic parameters  $V_{\text{max}}$  and  $K_{\text{m}}$  were obtained by plotting the exonuclease rates as a function of DNA concentration and fitting the data to the Michaelis–Menten equation using Origin software.

**DNA Partitioning Assays between the Exonuclease and Polymerase Active Sites.** Assays contained  $1 \mu\text{M}$  DNA ( $\text{DNA}_n$ ) with a T/G or a G/G mismatch at the primer 3'-terminus in reaction buffer containing the correct dNTP needed for elongation of  $\text{DNA}_n$  into  $\text{DNA}_{n+1}$  and the correct dNTP needed for elongation of  $\text{DNA}_{n-1}$  (i.e., the DNA generated when the exonuclease removes the incorrect nucleotide at the primer 3'-terminus) into  $\text{DNA}_n$ . A set of parallel reactions contained  $\text{DNA}_{14\text{G}}$ , varying concentrations of dCTP, and fixed concentrations of dGTP with the correct nucleotides for elongating this DNA by two nucleotides. Reactions were initiated by the addition of 20 nM enzyme and quenched after a designated time as described above. Upon formation of the E– $\text{DNA}_n$  complex, the next correct nucleotide can potentially be added directly onto the mismatch. The rate of dNTP polymerization directly onto the mismatch was measured in independent control reactions and all data were corrected for this relatively slow process. The exonuclease can remove the mismatch to generate  $\text{DNA}_{n-1}$ , which can suffer one of three fates: removal of additional nucleotides via the exonuclease, dissociation from the enzyme, or direct translocation to the polymerase active site to allow polymerization of two correct dNTPs to generate  $\text{DNA}_{n+1}$ . The fraction of DNA that was moved directly from the exonuclease site to the polymerase site was obtained by dividing  $\text{DNA}_{n+1}$  by the sum of  $\text{DNA}_{n+1}$  and all exonuclease products ( $\text{DNA}_{n-1}$ ,  $\text{DNA}_{n-2}$ , etc.). The amount of  $\text{DNA}_{n+1}$  was corrected for the direct addition of the next correct dNTP onto the mismatch.

## RESULTS

To better understand the relationship between the polymerase and exonuclease activities of UL30 ( $\pm$ UL42), we examined coordinated exonuclease and polymerase activity using a series of oligonucleotides of defined sequence (Table 1). Work by Gottlieb et al. showed that UL30 alone interacts with ca. 14 nucleotides of double-stranded DNA, while the UL30–UL42 complex interacts with 28 nucleotides of double-stranded DNA.<sup>25</sup> On the basis of these data, we designed DNA substrates whose length would allow them to interact either with only UL30 or with both the UL30 and UL42 subunits of the UL30–UL42 complex to differentially probe the importance of interactions with just UL30 or UL30 plus UL42.

**Polymerization of Correct Versus Incorrect dNTPs by UL30 and UL30–UL42.** Previous work showed that the presence of UL42 did not affect the rate of misincorporation by

UL30 that lacked exonuclease activity (UL30 (exo–)).<sup>7</sup> Indeed, we likewise observed that UL42 did not affect misincorporation by UL30 (exo–) using DNAs whose length should only permit contact with UL30 as well as those long enough to contact both subunits of the UL30–UL42 complex ( $\text{DNA}_{15\text{C}}$  and  $\text{DNA}_{35\text{C}}$ ; data not shown). As reported by Parris and co-workers with other DNAs,<sup>6</sup> the presence of exonuclease activity decreased mismatch accumulation with  $\text{DNA}_{15\text{C}}$  and  $\text{DNA}_{35\text{C}}$  only 4- to 16-fold in our findings.

To better understand the relatively small effect of the exonuclease activity on accumulation of mismatches, we initially determined the optimal substrate for the exonuclease. Work with other polymerase-associated exonucleases has shown that they unwind one or more base pairs of the correctly base-paired duplex DNA prior to hydrolyzing the 3'-terminal phosphodiester bond.<sup>26</sup> As the denaturing of a correct base pair is energetically unfavorable, this predicts that a substrate that avoids this energetically unfavorable process by having unwound base pairs at the 3' end of the primer–template duplex will be a better substrate than one with all correct base pairs. Using a series of DNAs containing increasing numbers of mismatches at the 3'-terminus (Table 1), we measured the efficiency with which the exonuclease removes the 3'-terminal nucleotide. Figure 1 shows that the highest efficiency ( $k_{\text{cat}}/$

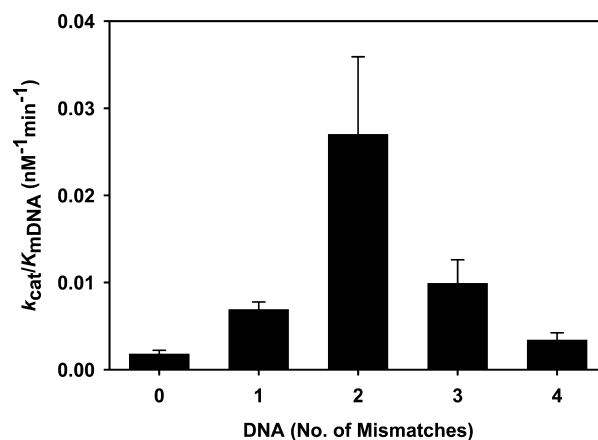

**Figure 1.** Exonuclease assays using 15/33 mer duplex DNA containing 0–4 mismatches at the primer terminus ( $\text{DNA}_{15\text{C}}$ ,  $\text{DNA}_{15\text{TG}}$ ,  $\text{DNA}_{2\text{MM}}$ ,  $\text{DNA}_{3\text{MM}}$ , and  $\text{DNA}_{4\text{MM}}$ ). Plot of  $k_{\text{cat}}/K_{\text{mDNA}}$  as a function of the number of mismatches present at the primer terminus.

$K_{\text{mDNA}}$ ) for the exonuclease occurred on the substrate containing two mismatches. Similar data were obtained for the UL30–UL42 complex, indicating that the enzyme unwinds two nucleotides for optimal exonuclease activity. As the efficiency of the exonuclease activity may depend on the sequence of the oligonucleotide substrate, the precise  $k_{\text{cat}}/K_{\text{mDNA}}$  may vary with different sequences.

Herpes polymerase is a highly processive enzyme due to a high rate of dNTP polymerization ( $k_{\text{pol}} = 157 \text{ s}^{-1}$ ) in conjunction with a slow rate of DNA dissociation ( $k_{\text{off}} = 0.07 \text{ s}^{-1}$ ) after incorporation of a dNTP.<sup>7</sup> This is true even in the absence of its processivity factor UL42. Furthermore, pre-steady-state studies by Parris and co-workers showed that the 3'–5' exonuclease rapidly cleaves a correctly base-paired nucleotide with a rate constant of  $6 \text{ s}^{-1}$  and an incorrectly base-paired nucleotide with a rate constant of  $17 \text{ s}^{-1}$ .<sup>7</sup> Although the high exonuclease rate and slow DNA dissociation rate would seem to predict that the exonuclease will processively

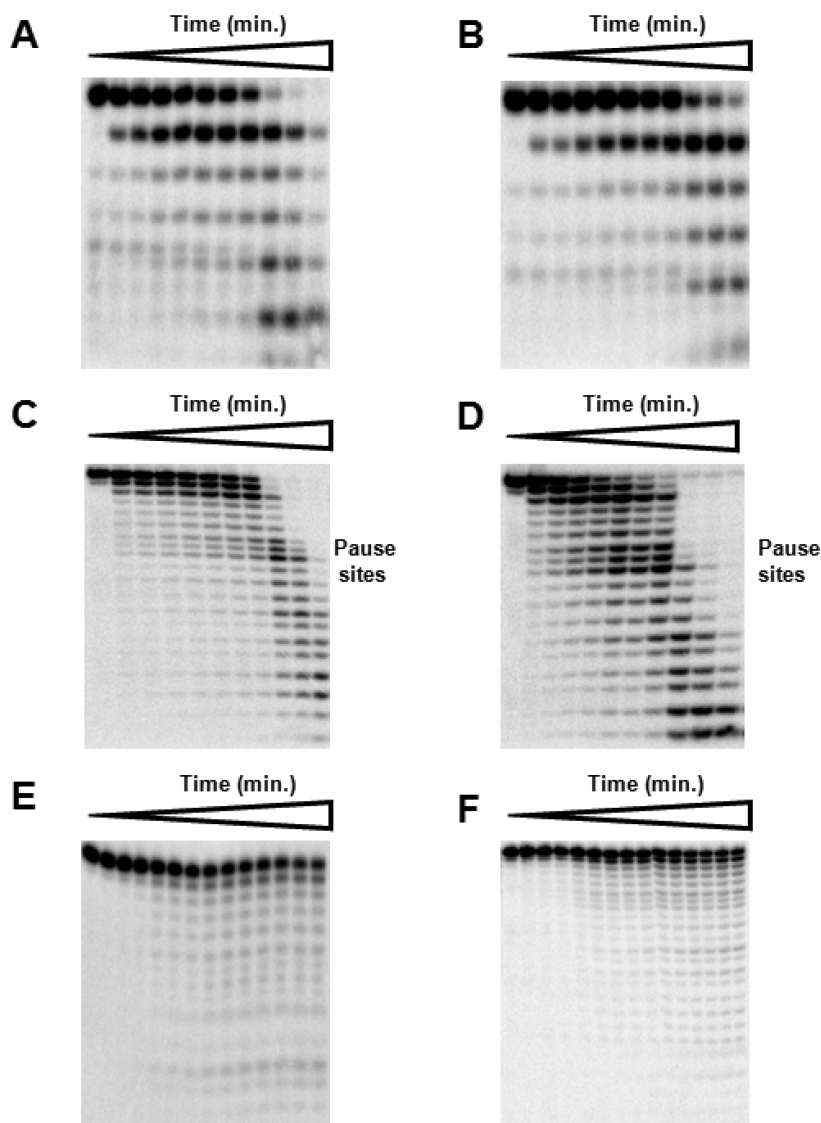

**Figure 2.** Distributive removal of UL30 exonuclease by nucleotides. UL30 or UL30–UL42 was incubated with DNA ( $1\ \mu\text{M}$ ) and aliquots were taken out at various times. (A) Phosphorimages of the products of DNA<sub>15SS</sub> degradation using UL30–UL42. (B) Phosphorimages of the products of DNA<sub>15SS</sub> degradation using UL30. (C) Phosphorimages of the products of DNA<sub>35SS</sub> degradation using UL30–UL42. (D) Phosphorimages of the products of DNA<sub>35SS</sub> degradation using UL30. The time points for legends (A)–(D) were 0, 0.25, 0.5, 0.75, 1, 1.25, 1.5, 2, 5, 7, and 10 min. (E) Phosphorimages of the products of DNA<sub>35C</sub> degradation using UL30–UL42 at time intervals 0, 0.5, 1, 2, 5, 7, 10, 15, 20, 25, 30, 40, 50, and 60 min. (F) Phosphorimages of the products of DNA<sub>35C</sub> degradation using UL30 at time intervals 0, 0.25, 0.5, 1, 2, 5, 7, 10, 15, 20, 25, 30, 40, 50, and 60 min. Note: The gels shown are representative of experiments that were performed multiple times.

remove dNMPs, we instead found that the exonuclease was completely distributive (Figure 2). Under conditions of excess DNA over enzyme, after dissociating from a product DNA the enzyme will rebind to another molecule of the starting substrate DNA. Hence, whereas a processive exonuclease will remove several nucleotides before dissociating such that the products from the rapid removal of several nucleotides will appear before loss of the entire starting DNA (DNA<sub>*n*</sub>), a nonprocessive exonuclease will generate products in a sequential manner: first, products due to loss of one nucleotide (DNA<sub>*n*-1</sub>), then those due to loss of two nucleotides (DNA<sub>*n*-2</sub>), etc. Figure 2 shows that the UL30 exonuclease generated sequentially shorter products and indicates that the exonuclease acts in a distributive manner with both single- and double-stranded DNA. This occurred with single-stranded DNA using either UL30–UL42 or UL30 (Figure 2A–D), double-stranded DNA long enough to interact with both UL30 and UL42 (35 nucleotides long,

Figure 2E and F), or only long enough to interact with UL30 (15 nucleotides long, data not shown). These data also show that UL42 does not impact the nonprocessive nature of the exonuclease (compare Figure 2A–F). While degrading DNA, the exonuclease activity clearly paused at different sites in the DNA. The cause of these pauses is unclear. Thus, even though the enzyme contains a very rapid exonuclease and DNA dissociates slowly after dNTP polymerization, UL30 nonprocessively removes nucleotides from DNA.

**DNA's Inefficient Translocation between the Exonuclease and Polymerase Active Sites.** One mechanism that can potentially account for the relatively small effect of the exonuclease on accumulation of products containing incorrect nucleotides is the inefficient transfer of DNA between the polymerase and exonuclease active sites. To test this hypothesis, we measured the efficiency of DNA translocation from the exonuclease active site to the polymerase active site as

shown in Scheme 1. Assays contained a large excess of DNA containing a single mismatch at the primer 3'-terminus (DNA<sub>n</sub>) along with the dNTPs that can form a correct base pair with template positions *n* (which in the starting DNA is a mismatch) and *n* + 1 (i.e., the nucleotide needed for elongation of DNA<sub>n</sub>). The DNA<sub>n</sub> awaits three potential fates upon binding to UL30 (or UL30–UL42): it can simply dissociate from the enzyme, forming no product and freeing the enzyme to bind another DNA<sub>n</sub>; the polymerase can add the next correct dNTP onto the mismatch, thereby generating DNA<sub>n+1</sub>; or the exonuclease can hydrolyze the mismatch, thereby generating DNA<sub>n-1</sub>. Control experiments showed that in the presence of excess DNA<sub>n</sub> where the base pair at the primer 3'-terminus is a mismatch and only the next correct dNTP for addition onto DNA<sub>n</sub> (dGTP), UL30 generated large amounts of shortened DNA (DNA<sub>n-1</sub>, DNA<sub>n-2</sub>, etc.) products and only small amounts of DNA<sub>n+1</sub>. Thus, the rate of addition of dGTP onto a mismatch was indeed slow and the exonuclease could efficiently remove the mismatch (Figure 3C).

**Scheme 1. Kinetic Scheme Depicting the DNA Switching Between Polymerase and Exonuclease Sites**

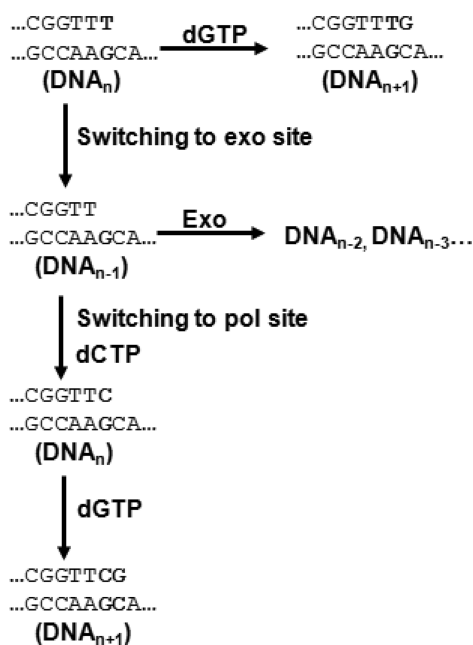

Upon removal of the mismatch via exonuclease activity and generation of DNA<sub>n-1</sub>, the DNA<sub>n-1</sub> can potentially dissociate from the enzyme, leading to the accumulation of DNA<sub>n-1</sub> (in this case the large excess of DNA<sub>n</sub> minimizes the possibility that DNA<sub>n-1</sub> will rebind the enzyme), remain in the exonuclease active site and undergo another round of nucleotide excision (leading to DNA<sub>n-2</sub>), or move intramolecularly to the polymerase active site at which point the highly processive polymerase can incorporate two nucleotides and generate DNA<sub>n+1</sub>. Thus, an efficient intramolecular transfer of DNA from the exonuclease to polymerase active sites will result in large amounts of DNA<sub>n+1</sub> relative to exonuclease products and an inefficient transfer will give the converse result.

Surprisingly, UL30 did not efficiently translocate DNA between the exonuclease and polymerase active sites (Figure 3 and Table 2). Even with saturating levels of dNTPs (2000 μM dCTP and 100 μM dGTP<sup>a</sup>), the fraction of DNA<sub>n-1</sub> extended

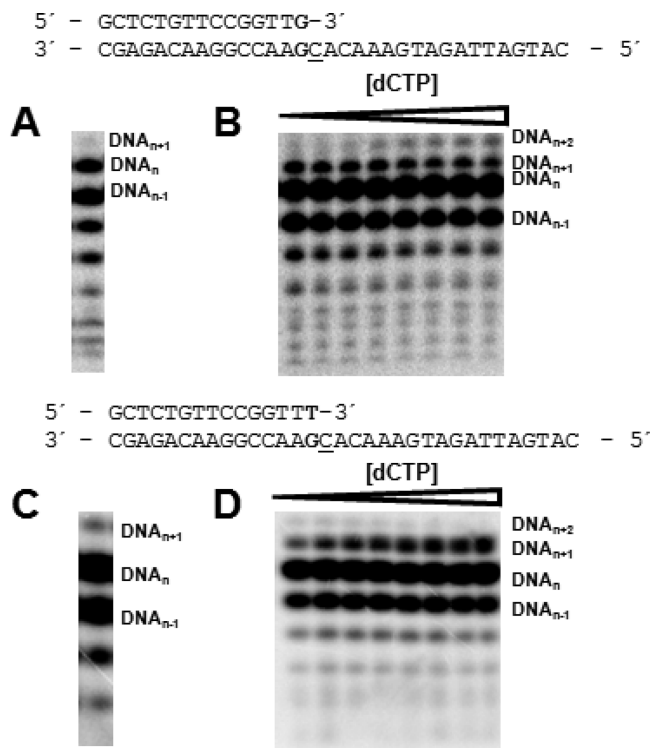

**Figure 3. Translocation of DNA<sub>15GG</sub> and DNA<sub>15TG</sub> between polymerase and exonuclease sites.** UL30 was incubated with primer–template (1 μM) in the presence of either 100 μM dGTP or 100 μM dGTP and varying concentrations of dCTP, the next correct incoming nucleotide. Reactions were quenched after 5 min and reaction products were separated by denaturing gel electrophoresis. The sequences of DNAs containing G/G and T/G mismatches are shown. (A) Phosphorimage of the products of DNA extension and degradation using 100 μM dGTP and DNA containing a G/G mismatch (DNA<sub>15GG</sub>). (B) Phosphorimages of the products of DNA<sub>15GG</sub> extension and degradation using varying dCTP concentrations (5, 10, 50, 100, 200, 400, 800, and 2000 μM) and dGTP at 100 μM. (C) Phosphorimage of the products of DNA extension and degradation with UL30 using 100 μM dGTP and DNA containing a T/G mismatch (DNA<sub>15TG</sub>). (D) Phosphorimages of the products of DNA<sub>15TG</sub> extension and degradation using varying dCTP concentrations (5, 10, 50, 100, 200, 400, 800, and 2000 μM) and dGTP at 100 μM.

**Table 2. Fraction of DNA Extended by UL30 Using DNA<sub>15TG</sub>, DNA<sub>15GG</sub>, and DNA<sub>35TG</sub>**

P/T (mer)	DNA mismatch	incoming dNTP	[P/(P+E)] <sub>max</sub>
15/33	T/G	dCTP (vary)	0.30 <sup>a</sup>
		dGTP (fixed)	
15/33	G/G	dCTP (vary)	0.23 <sup>a</sup>
		dGTP (fixed)	
35/33	T/G	dCTP (vary)	0.30 <sup>a</sup>
		dGTP (fixed)	

<sup>a</sup>[P/(P+E)] is the fraction of DNA that moved directly from the exonuclease to the polymerase site without dissociating from the enzyme and then extended via dNTP polymerization. The fraction of DNA transferred from exonuclease to the polymerase site was corrected for the amount of product formed by the direct addition of dGTP (100 μM) onto the mismatch terminus.

using DNA<sub>15TG</sub> as the substrate DNA was only around 30%. Increasing the length of the DNA (DNA<sub>35TG</sub>) did not significantly affect the efficiency of translocation as measured

under conditions of saturating dCTP and dGTP. We considered the possibility that this low efficiency of translocation followed by dNTP polymerization was a consequence of the mismatch. However, replacing the G–T mismatch with a G–G mismatch did not significantly alter the efficiency of translocation. We also excluded the possibility that the inefficient transfer was an artifact due to inefficient elongation of the exonuclease product, the correctly base-paired DNA<sub>*n*-1</sub>. In control experiments we incubated UL30 with DNA<sub>*n*-1</sub>, 5 μM dCTP, and 100 μM dGTP. Of the elongated DNA<sub>*n*-1</sub>, 90% was converted to DNA<sub>*n*+1</sub> (or longer) and only 10% to DNA<sub>*n*</sub>. Thus, UL30 efficiently polymerizes two nucleotides onto the correctly base-paired DNA<sub>*n*-1</sub>.

We also tested if UL42 could increase the efficiency with which DNA translocates from the exonuclease to the polymerase active site. Tables 2 and 3 show that both UL30

**Table 3. Fraction of DNA Extended by UL30–UL42 Using DNA<sub>15TG</sub> and DNA<sub>35TG</sub>**

P/T (mer)	DNA mismatch	incoming dNTP	[P/(P+E)] <sub>max</sub>
15/33	T/G	dCTP	0.32 <sup>a</sup>
		dGTP	
35/33	T/G	dCTP	0.35 <sup>a</sup>
		dGTP	

<sup>a</sup>The fraction of DNA transferred from exonuclease to the polymerase site was corrected for the amount of product formed by the direct addition of dGTP onto the mismatch (100 μM).

and the UL30–UL42 complex translocate DNA equally inefficiently from the exonuclease to the polymerase active site. This was true for DNA that was too short to interact with both UL30 and UL42 (DNA<sub>15TG</sub>) and that which was long enough to interact with both proteins (DNA<sub>35TG</sub>).

We also measured the efficiency of DNA translocation by two other polymerases that contain both polymerase and exonuclease activities, Klenow Fragment and T4 DNA polymerase, to rule out the possibility that these results reflected the experimental protocol or DNA sequences. Under conditions of saturating dCTP and dGTP concentrations, Klenow Fragment and T4 DNA polymerases transferred 91% and 83% of the DNA, respectively, from the exonuclease active site to the polymerase active site via direct intramolecular transfer. Furthermore, in the case of T4 translocation was measured in the absence of the T4 DNA polymerase processivity factor gp45. As gp45 greatly decreases the rate at which T4 polymerase dissociates from DNA, this transfer is likely much less efficient than what would normally occur in vivo when gp45 is present. Thus, the inefficient translocation of DNA between polymerase and exonuclease active sites appears to be a UL30 ± UL42-specific phenomenon.

**Independent DNA Binding of UL30 Polymerase and Exonuclease Sites.** The inefficient translocation between the exonuclease and polymerase active sites in conjunction with the nonprocessive nature of the exonuclease raised the possibility that UL30 might contain at least partially independent DNA binding domains for the polymerase and exonuclease active sites. To test this hypothesis, we determined how a tightly bound primer–template in the polymerase active site affects exonuclease activity. We accomplished this by using aphidicolin to generate a UL30–DNA–aphidicolin ternary complex and measuring the effect on exonuclease activity.

Previous studies showed that aphidicolin inhibits B-family DNA polymerases by forming an enzyme–DNA–aphidicolin ternary complex in the polymerase active site.<sup>27–29</sup> Even though aphidicolin bears no obvious resemblance to a nucleoside triphosphate, it binds competitively with respect to the dNTP and forms an E–DNA–aphidicolin ternary complex.<sup>27,28</sup> Consistent with previous work using long, homopolymeric primer–templates to measure polymerase activity of herpes polymerase as well as studies on other B-family polymerases,<sup>1,28</sup> we found that aphidicolin potentially inhibits elongation of short, synthetic primer–templates of defined sequence. Aphidicolin inhibition of dNTP polymerization when the next templating nucleotide was dG, dA, or dC (DNA<sub>14G</sub>, DNA<sub>14A</sub>, or DNA<sub>14C</sub>) gave IC<sub>50</sub> values of 1.2 ± 0.1, 3.0 ± 0.4, and 2.5 ± 0.3 μM, respectively, in assays containing 5 μM dNTP.

We likewise measured the effect of aphidicolin on exonuclease activity using both single- and double-stranded DNAs as substrate. Figure 4 shows that even high

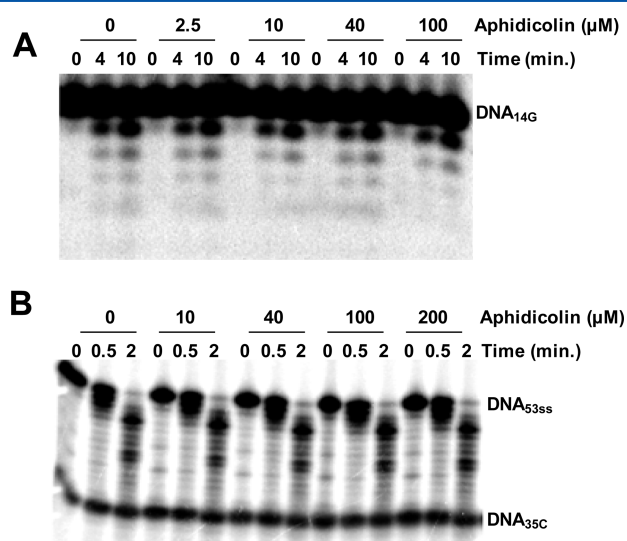

**Figure 4.** Effects of aphidicolin on exonuclease activity. DNA<sub>14G</sub> or DNA<sub>35C</sub> (1 μM) was incubated with reaction buffer containing varying concentrations of aphidicolin. Reactions were initiated by adding UL30 or UL30–UL42 and quenched at various time intervals. Reaction products were separated using 20% polyacrylamide denaturing gel electrophoresis and imaged using a phosphorimager. (A) Phosphorimages of the products of exonucleolytic cleavage of 14/33 mer duplex DNA (DNA<sub>14G</sub>) at 0, 4, and 10 min with UL30–UL42 as a function of increasing aphidicolin concentration from 0 to 100 μM. (B) Phosphorimages of the products of exonucleolytic cleavage of DNA<sub>53ss</sub> at 0, 0.5, and 2 min with UL30 as a function of increasing aphidicolin concentration from 0 to 200 μM. Note that the assay contained both DNA<sub>35C</sub> and DNA<sub>53ss</sub>.

concentrations of aphidicolin did not affect exonuclease activity of either UL30 or UL30–UL42 when the effect was measured on either a primer–template or single-stranded DNA. Especially striking is the lack of inhibition of exonuclease activity on a primer–template as, in the presence of aphidicolin, a primer–template will be tightly bound to the polymerase active site.<sup>b</sup>

The observation that aphidicolin does not inhibit exonuclease activity on a primer–template even though the primer–template will be more tightly bound in the polymerase active site strongly suggested that the polymerase and exonuclease

active sites have independent DNA binding domains. To provide further evidence for this conclusion, we measured exonuclease activity on a single-stranded DNA in assays containing increasing concentrations of aphidicolin as well as a primer–template. Under these conditions, adding aphidicolin will result in the primer–template tightly binding in the polymerase active site. As shown in Figure 4B, increasing the binding of the primer–template to the polymerase active site by adding aphidicolin did not affect exonuclease activity on the single-stranded DNA. The inability of a primer–template that is bound to the polymerase active site to inhibit exonuclease activity indicates that the two activities have independent binding domains.

## DISCUSSION

We examined the coordination between the polymerase and exonuclease activities of UL30 and the potential roles of UL42. Surprisingly, there is very little coordination between the two activities and they likely have independent DNA binding domains. In support of this idea, the intramolecular translocation of DNA from the exonuclease to the polymerase active site was relatively inefficient and the presence of a DNA in the polymerase active site did not inhibit exonuclease activity. Interestingly, UL42 did not enhance the coordination of the polymerase and exonuclease activities even though UL42 helps tether the polymerase to DNA.

Two distinct data support the surprising conclusion that DNA does not efficiently translocate between the polymerase and exonuclease sites on UL30. (1) In assays containing a large excess of DNA, UL30 (exo+) and UL30 (exo−) accumulate mismatch products at similar rates.<sup>6</sup> If the product resulting from incorporation of a wrong dNTP had efficiently translocated to the exonuclease active site, the highly active exonuclease should have significantly decreased the accumulation of the mismatched product. In contrast, the exonuclease activity associated with other DNA polymerases including T4, T7, *E. coli* DNA pol II, and *E. coli* DNA pol III decreases the accumulation of mismatched products by ~100-fold.<sup>30–32</sup> (2) Assays that directly measured translocation of DNA from the exonuclease to the polymerase active site followed by dNTP incorporation site showed that even under conditions of saturating dNTPs to maximize elongation of the DNA upon translocation into the polymerase active site, UL30 did not efficiently transfer the DNA. With the different DNAs examined, only around 30% of the DNA moved directly from the exonuclease active site to the polymerase active site without dissociating from the enzyme. Furthermore, the biologically relevant efficiency involves two translocation events: polymerase to exonuclease followed by exonuclease to polymerase. Thus, the measured values represent a maximal efficiency with which the DNA could transit the biochemically relevant polymerase to the exonuclease to polymerase pathway. Although we cannot measure the efficiency of transfer from the polymerase to the exonuclease active site, the minimal impact of the exonuclease on the accumulation of mismatches suggests that this translocation event is likewise inefficient. Two other polymerases, Klenow Fragment and T4 polymerase, translocated DNA between these sites much more efficiently than UL30 (91% and 83% intramolecular translocation, respectively). This occurred even though Klenow Fragment and T4 polymerase have much lower processivity than UL30 due to the inherent biological properties of *E. coli* DNA polymerase I and the absence of the T4 polymerase processivity

factor gp45, respectively. Our results with T4 DNA polymerase are also in excellent agreement with those obtained by Reddy et al. when they observed 85% switching efficiency for T4 polymerase in the absence of gp45.<sup>33</sup> The mechanism of DNA transfer between the exonuclease and polymerase sites has been studied for a number of other polymerases including T7, human mitochondrial DNA polymerase, and  $\Phi$ 29 DNA polymerase.<sup>33–37</sup> In each of these polymerases DNA translocates between the two sites mainly through intramolecular transfer, in contrast to UL30 that exhibits very inefficient intramolecular transfer.

The inefficient translocation of the DNA raises the question of how the two activities function together in vivo and suggests several scenarios. (1) The active sites do not function in a coordinated manner in vivo. Herpes forms a distinct replication compartment within the nucleus of the infected cell.<sup>38</sup> The compartment contains large amounts of replication enzymes and the time lag generated by frequent dissociation/reassociation of polymerases at the replication fork might be short enough to not impede replication significantly. (2) Other proteins not present in this simplified system modulate the translocation of DNA between the two active sites. These could include, for example, the herpes-encoded single-stranded DNA binding protein UL29, the herpes helicase–primase, or a cellular protein that herpes polymerase recruits to the replication fork. One protein that does *not* enhance this translocation is UL42, as evidenced by the low efficiency of translocation for both UL30 and UL30–UL42. (3) Herpes polymerase might employ a “proofreading in trans” strategy. For example, the herpes replisome presumably contains at least two polymerases (A and B) to account for leading and lagging strand replication. If both polymerase molecules formed a dimer under these conditions, the exonuclease active site of A could proofread for the polymerase active site of B and vice versa. This approach would be analogous to the trans arrangement of the active sites for generation of the aminoacyl adenylate and the transfer of the activated aminoacyl group to the acceptor tRNA in some dimeric tRNA synthetases.<sup>39</sup> Experiments to test these ideas are in progress.

The low efficiency of translocation between the polymerase and exonuclease active sites may also reflect the large distance between the two sites. Structural studies of UL30 showed that the polymerase and exonuclease sites are 45–60 Å apart.<sup>22</sup> Figure 5 shows the overall structure of UL30 in which the D368 residue of the exonuclease active site and the D717 and D888 residues of the palm domain are highlighted. This large distance between the two sites might potentially reduce the efficiency of intramolecular transfer of DNA. Structural studies of other polymerases including Klenow Fragment, T4, T7, and RB69 DNA polymerase have revealed that the distance between the polymerase and exonuclease sites is around 20–30 Å,<sup>40–44</sup> significantly closer than in UL30.

In contrast to the high processivity of the polymerase activity, the exonuclease degrades both single-stranded and double-stranded DNA in a distributive manner. A priori, one would expect the exonuclease to have degraded DNA processively as the rate of nucleotide hydrolysis ( $6 \text{ s}^{-1}$  on a correctly base-paired primer–template and  $17 \text{ s}^{-1}$  on a primer–template containing a mismatch at the 3′-terminus) is much faster than the rate of DNA dissociation ( $0.07 \text{ s}^{-1}$  for a correctly base-paired primer–template), and processivity reflects a competition between dissociation and hydrolysis.<sup>7</sup> One potential solution to this apparent dichotomy would be if DNA

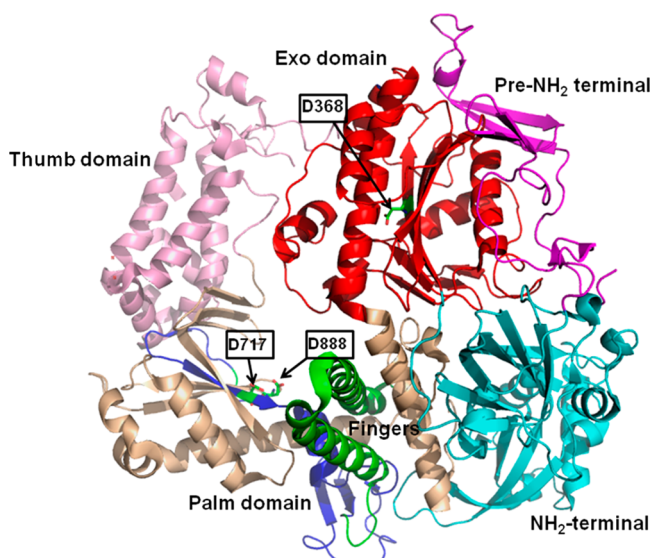

**Figure 5.** Structure of HSV DNA polymerase. The pre-NH<sub>2</sub>-terminal, NH<sub>2</sub>-terminal, fingers, palm, thumb, and exonuclease domains are colored magenta, cyan, green, blue, pink, and red, respectively. The position of D368 residue in the exonuclease active site and the D717 and D888 residues in the polymerase active site are marked with arrows. The distance between the carboxylate oxygens of D368 and the carboxylate oxygens of D717 is 37 Å, and the distance between the carboxylate oxygens of D368 and the carboxylate oxygens of D888 is 56 Å.

dissociates from the exonuclease active site much more rapidly than from the polymerase active site. The aforementioned DNA dissociation rate reflects how fast DNA dissociates immediately after dNTP polymerization when the DNA was necessarily in the polymerase active site. If the DNA binding domains are relatively independent, as suggested by the fact that forming an E–DNA–aphidicolin ternary complex in the polymerase active site did not affect exonuclease activity, this would provide a rationale for very different dissociation rates. Alternatively, after completing one catalytic cycle the exonuclease might require that the just-processed DNA dissociate from this active site before initiating the next catalytic cycle.

Cowart et al. reported that the exonuclease sites of T4, T7, and Klenow Fragment require 2, 3, and 4 base pairs, respectively, of the primer strand to melt out for the exonucleolytic removal of nucleotides from the primer terminus.<sup>26</sup> We observed that both UL30 and UL30–UL42 enzymes require the substrate to have two unwound nucleotides for optimal activity. The requirement of two unwound base pairs is similar to that of the T4 DNA polymerase, another B-family polymerase, and slightly shorter than the two A-family enzymes.

The independence of the DNA binding domains for the exonuclease and polymerase active sites varies significantly among DNA polymerases. Just as with UL30, Klenow Fragment, an A-family enzyme, has independent DNA binding domains for its polymerase and 3′-5′ exonuclease functions.<sup>45</sup> DNA polymerase  $\epsilon$ , a B-family enzyme, has partially independent binding domains. Forming a pol  $\epsilon$ –DNA–aphidicolin complex in the polymerase active site gives partial inhibition of exonuclease activity.<sup>27</sup> In contrast, the B-family polymerase from RB69 appears to have completely overlapping DNA binding domains.<sup>46</sup> Structural studies of DNA bound to

the polymerase or exonuclease active sites of RB69 polymerase show that the duplex portion of each DNA lies in the same channel. A short strand of single-stranded DNA (three nucleotides) then extends from near the polymerase active site to the exonuclease site.<sup>46</sup> Thus, although the catalytic cores for exonuclease and dNTP polymerizing activity appear completely distinct in all polymerases, the DNA binding domains may or may not overlap.

Together, these studies have shown that the polymerase and exonuclease activities of UL30 are remarkably noncoordinated with respect to each other. This includes apparently independent DNA binding domains and remarkably inefficient transfer between the two active sites. UL42, even though it binds DNA and enhances the processivity of dNTP polymerization, has no detectable impact on these parameters. This noncoordinated behavior of the two activities raises the question of how the two activities function together at the replication fork as well as the possibility that polymerase inhibitors may target herpes DNA synthesis via two mechanisms: direct inhibition of dNTP polymerization and exonuclease-mediated DNA destruction.

## AUTHOR INFORMATION

### Corresponding Author

\* Phone: (303) 492-7027. Fax: (303) 492-5894. E-mail: Kuchta@colorado.edu.

### Funding

This work was supported by NIH grant AI59764 to R.D.K.

### Notes

The authors declare no competing financial interest.

## ABBREVIATIONS

BSA, bovine serum albumin; dNTP, 2′-deoxyribonucleoside 5′-triphosphate; DTT, dithiothreitol; EDTA, ethylenediamine tetraacetic acid; Hepes, 4-(2-hydroxyethyl)-1-piperazine-ethanesulfonic acid; HSV, herpes simplex virus; P/T, primer/template; UL30, HSV1 DNA polymerase catalytic subunit that harbors both polymerase and exonuclease activities; UL30 (exo−), HSV1 DNA polymerase subunit lacking exonuclease activity

## ADDITIONAL NOTES

<sup>a</sup>Once the mismatched DNA is transferred to the exonuclease site and the incorrect nucleotide is removed, dCTP and dGTP are the correct dNTPs for addition of the next two nucleotides. Control experiments involving varying the concentrations of these two dNTPs showed that these concentrations give maximal intramolecular translocation of the DNA from the exonuclease to polymerase active sites (data not shown).

<sup>b</sup>Frank et al. reported that high concentrations of aphidicolin inhibit the exonuclease activity of HSV pol in contrast to our results.<sup>1</sup> We suspect that this discrepancy resulted from the different DNAs used. In contrast to the relatively short oligonucleotides of defined sequence we used, they employed long repeating polymers such as poly(dG) and poly(dC–dG). Apart from using different sequences, the utilized phosphonoformic acid resistant HSV strains might also account for the discrepancy.

## REFERENCES

- (1) Frank, K. B., Derse, D. D., Bastow, K. F., and Cheng, Y. C. (1984) Novel interaction of aphidicolin with herpes simplex virus DNA



polymerase and polymerase-associated exonuclease. *J. Biol. Chem.* 259, 13282–13286.

(2) Severson, J. L., and Tyring, S. K. (1999) Viral disease update. *Curr. Probl. Dermatol.* 11, 43–70.

(3) Boehmer, P. E., and Lehman, I. R. (1997) Herpes simplex virus DNA replication. *Annu. Rev. Biochem.* 66, 347–384.

(4) Chattopadhyay, S., Chen, Y., and Weller, S. K. (2006) The two helicases of herpes simplex virus type 1 (HSV-1). *Front. Biosci., Landmark Ed.* 11, 2213–2223.

(5) Lehman, I. R., and Boehmer, P. E. (1999) Replication of herpes simplex virus DNA. *J. Biol. Chem.* 274, 28059–28062.

(6) Song, L., Chaudhuri, M., Knopf, C. W., and Parris, D. S. (2004) Contribution of the 3′- to 5′-exonuclease activity of herpes simplex virus type 1 DNA polymerase to the fidelity of DNA synthesis. *J. Biol. Chem.* 279, 18535–18543.

(7) Chaudhuri, M., Song, L., and Parris, D. S. (2003) The herpes simplex virus type 1 DNA polymerase processivity factor increases fidelity without altering pre-steady-state rate constants for polymerization or excision. *J. Biol. Chem.* 278, 8996–9004.

(8) Bravo, R., Frank, R., Blundell, P. A., and Macdonald-Bravo, H. (1987) Cyclin/PCNA is the auxiliary protein of DNA polymerase-delta. *Nature* 326, 515–517.

(9) Stukenberg, P. T., Studwell-Vaughan, P. S., and O'Donnell, M. (1991) Mechanism of the sliding beta-clamp of DNA polymerase III holoenzyme. *J. Biol. Chem.* 266, 11328–11334.

(10) Huber, H. E., Tabor, S., and Richardson, C. C. (1987) Escherichia coli thioredoxin stabilizes complexes of bacteriophage T7 DNA polymerase and primed templates. *J. Biol. Chem.* 262, 16224–16232.

(11) Tabor, S., Huber, H. E., and Richardson, C. C. (1987) Escherichia coli thioredoxin confers processivity on the DNA polymerase activity of the gene 5 protein of bacteriophage T7. *J. Biol. Chem.* 262, 16212–16223.

(12) Gottlieb, J., Marcy, A. I., Coen, D. M., and Challberg, M. D. (1990) The herpes simplex virus type 1 UL42 gene product: a subunit of DNA polymerase that functions to increase processivity. *J. Virol.* 64, 5976–5987.

(13) Tinker, R. L., Kassavetis, G. A., and Geiduschek, E. P. (1994) Detecting the ability of viral, bacterial and eukaryotic replication proteins to track along DNA. *EMBO J.* 13, 5330–5337.

(14) Kong, X. P., Onrust, R., O'Donnell, M., and Kuriyan, J. (1992) Three-dimensional structure of the beta subunit of E. coli DNA polymerase III holoenzyme: a sliding DNA clamp. *Cell* 69, 425–437.

(15) Krishna, T. S., Kong, X. P., Gary, S., Burgers, P. M., and Kuriyan, J. (1994) Crystal structure of the eukaryotic DNA polymerase processivity factor PCNA. *Cell* 79, 1233–1243.

(16) Shamoo, Y., and Steitz, T. A. (1999) Building a replisome from interacting pieces: sliding clamp complexed to a peptide from DNA polymerase and a polymerase editing complex. *Cell* 99, 155–166.

(17) Randell, J. C., and Coen, D. M. (2004) The herpes simplex virus processivity factor, UL42, binds DNA as a monomer. *J. Mol. Biol.* 335, 409–413.

(18) Parris, D. S., Cross, A., Haarr, L., Orr, A., Frame, M. C., Murphy, M., McGeoch, D. J., and Marsden, H. S. (1988) Identification of the gene encoding the 65-kilodalton DNA-binding protein of herpes simplex virus type 1. *J. Virol.* 62, 818–825.

(19) Weissbart, K., Chow, C. S., and Coen, D. M. (1999) Herpes simplex virus processivity factor UL42 imparts increased DNA-binding specificity to the viral DNA polymerase and decreased dissociation from primer-template without reducing the elongation rate. *J. Virol.* 73, 55–66.

(20) Chow, C. S., and Coen, D. M. (1995) Mutations that specifically impair the DNA binding activity of the herpes simplex virus protein UL42. *J. Virol.* 69, 6965–6971.

(21) Jiang, C., Komazin-Meredith, G., Tian, W., Coen, D. M., and Hwang, C. B. (2009) Mutations that increase DNA binding by the processivity factor of herpes simplex virus affect virus production and DNA replication fidelity. *J. Virol.* 83, 7573–7580.

(22) Liu, S., Knafels, J. D., Chang, J. S., Waszak, G. A., Baldwin, E. T., Deibel, M. R., Jr., Thomsen, D. R., Homa, F. L., Wells, P. A., Tory, M. C., Poorman, R. A., Gao, H., Qiu, X., and Seddon, A. P. (2006) Crystal structure of the herpes simplex virus 1 DNA polymerase. *J. Biol. Chem.* 281, 18193–18200.

(23) Ramirez-Aguilar, K. A., Low-Nam, N. A., and Kuchta, R. D. (2002) Key role of template sequence for primer synthesis by the herpes simplex virus 1 helicase-primase. *Biochemistry* 41, 14569–14579.

(24) Kuchta, R. D., Mizrahi, V., Benkovic, P. A., Johnson, K. A., and Benkovic, S. J. (1987) Kinetic mechanism of DNA polymerase I (Klenow). *Biochemistry* 26, 8410–8417.

(25) Gottlieb, J., and Challberg, M. D. (1994) Interaction of herpes simplex virus type 1 DNA polymerase and the UL42 accessory protein with a model primer template. *J. Virol.* 68, 4937–4945.

(26) Cowart, M., Gibson, K. J., Allen, D. J., and Benkovic, S. J. (1989) DNA substrate structural requirements for the exonuclease and polymerase activities of procaryotic and phage DNA polymerases. *Biochemistry* 28, 1975–1983.

(27) Cheng, C. H., and Kuchta, R. D. (1993) DNA polymerase epsilon: aphidicolin inhibition and the relationship between polymerase and exonuclease activity. *Biochemistry* 32, 8568–8574.

(28) Sheaff, R., Ilesley, D., and Kuchta, R. (1991) Mechanism of DNA polymerase alpha inhibition by aphidicolin. *Biochemistry* 30, 8590–8597.

(29) Pedrali-Noy, G., Spadari, S., Miller-Faures, A., Miller, A. O., Kruppa, J., and Koch, G. (1980) Synchronization of HeLa cell cultures by inhibition of DNA polymerase alpha with aphidicolin. *Nucleic Acids Res.* 8, 377–387.

(30) Kroutil, L. C., Register, K., Bebenek, K., and Kunkel, T. A. (1996) Exonucleolytic proofreading during replication of repetitive DNA. *Biochemistry* 35, 1046–1053.

(31) Cai, H., Yu, H., McEntee, K., Kunkel, T. A., and Goodman, M. F. (1995) Purification and properties of wild-type and exonuclease-deficient DNA polymerase II from Escherichia coli. *J. Biol. Chem.* 270, 15327–15335.

(32) Schaaper, R. M. (1993) Base selection, proofreading, and mismatch repair during DNA replication in Escherichia coli. *J. Biol. Chem.* 268, 23762–23765.

(33) Reddy, M. K., Weitzel, S. E., and von Hippel, P. H. (1992) Processive proofreading is intrinsic to T4 DNA polymerase. *J. Biol. Chem.* 267, 14157–14166.

(34) Donlin, M. J., Patel, S. S., and Johnson, K. A. (1991) Kinetic partitioning between the exonuclease and polymerase sites in DNA error correction. *Biochemistry* 30, 538–546.

(35) Lamichhane, R., Berezina, S. Y., Gill, J. P., Van der Schans, E., and Millar, D. P. (2013) Dynamics of site switching in DNA polymerase. *J. Am. Chem. Soc.* 135, 4735–4742.

(36) Johnson, A. A., and Johnson, K. A. (2001) Exonuclease proofreading by human mitochondrial DNA polymerase. *J. Biol. Chem.* 276, 38097–38107.

(37) Ibarra, B., Chemla, Y. R., Plyasunov, S., Smith, S. B., Lazaro, J. M., Salas, M., and Bustamante, C. (2009) Proofreading dynamics of a processive DNA polymerase. *EMBO J.* 28, 2794–2802.

(38) Uprichard, S. L., and Knipe, D. M. (1997) Assembly of herpes simplex virus replication proteins at two distinct intranuclear sites. *Virology* 229, 113–125.

(39) Ward, W. H., and Fersht, A. R. (1988) Tyrosyl-tRNA synthetase acts as an asymmetric dimer in charging tRNA. A rationale for half-of-the-sites activity. *Biochemistry* 27, 5525–5530.

(40) Beese, L. S., and Steitz, T. A. (1991) Structural basis for the 3′-5′ exonuclease activity of Escherichia coli DNA polymerase I: a two metal ion mechanism. *EMBO J.* 10, 25–33.

(41) Wang, J., Yu, P., Lin, T. C., Konigsberg, W. H., and Steitz, T. A. (1996) Crystal structures of an NH<sub>2</sub>-terminal fragment of T4 DNA polymerase and its complexes with single-stranded DNA and with divalent metal ions. *Biochemistry* 35, 8110–8119.

(42) Doublet, S., Tabor, S., Long, A. M., Richardson, C. C., and Ellenberger, T. (1998) Crystal structure of a bacteriophage T7 DNA replication complex at 2.2 Å resolution. *Nature* 391, 251–258.

(43) Franklin, M. C., Wang, J., and Steitz, T. A. (2001) Structure of the replicating complex of a pol alpha family DNA polymerase. *Cell* 105, 657–667.

(44) Xia, S., Vashishtha, A., Bulkley, D., Eom, S. H., Wang, J., and Konigsberg, W. H. (2012) Contribution of partial charge interactions and base stacking to the efficiency of primer extension at and beyond abasic sites in DNA. *Biochemistry* 51, 4922–4931.

(45) Catalano, C. E., and Benkovic, S. J. (1989) Inactivation of DNA polymerase I (Klenow fragment) by adenosine 2',3'-epoxide 5'-triphosphate: evidence for the formation of a tight-binding inhibitor. *Biochemistry* 28, 4374–4382.

(46) Aller, P., Duclos, S., Wallace, S. S., and Doublet, S. (2011) A crystallographic study of the role of sequence context in thymine glycol bypass by a replicative DNA polymerase serendipitously sheds light on the exonuclease complex. *J. Mol. Biol.* 412, 22–34.