

Testing for Depéret’s Rule (Body Size Increase) in Mammals using Combined Extinct and Extant Data

FOLMER BOKMA^{1,*}, MARC GODINOT², OLIVIER MARIDET³, SANDRINE LADEVÈZE⁴, LOÏC COSTEUR⁵, FLORÉAL SOLÉ⁶,
EMMANUEL GHEERBRANT⁴, STÉPHANE PEIGNÉ⁴, FLORIAN JACQUES⁴, AND MICHEL LAURIN⁴

¹Department of Ecology and Environmental Science, Umeå University, SE-901 87 Umeå, Sweden; ²UMR 7207, CNRS/MNHN/IUPMC, Ecole Pratique des Hautes Etudes, Paris, France; ³Jurassica Museum, route de Fontenais 21, 2900 Porrentruy, Switzerland; ⁴UMR 7207, CNRS/MNHN/IUPMC, Centre de Recherche sur la Paléodiversité et les Paléoenvironnements (CR2P), Muséum national d’Histoire naturelle, Département Histoire de la Terre, 57 rue Cuvier, F-75231 Paris Cedex 05, France; ⁵Naturhistorisches Museum Basel, Augustinergasse 2, 4001 Basel, Switzerland; and ⁶Department of Palaeontology, Royal Belgian Institute of Natural Sciences, 29, rue Vautier, 1000 Brussels, Belgium

*Correspondence to be sent to: Department of Ecology and Environmental Science, Umeå University, SE - 901 87 Umeå, Sweden;
E-mail: folmer.bokma@emg.umu.se

Received 7 October 2014; reviews returned 9 December 2014; accepted 23 September 2015

Associate Editor: Norm MacLeod

Abstract.—Whether or not evolutionary lineages in general show a tendency to increase in body size has often been discussed. This tendency has been dubbed “Cope’s rule” but because Cope never hypothesized it, we suggest renaming it after Depéret, who formulated it clearly in 1907. Depéret’s rule has traditionally been studied using fossil data, but more recently a number of studies have used present-day species. While several paleontological studies of Cenozoic placental mammals have found support for increasing body size, most studies of extant placentals have failed to detect such a trend. Here, we present a method to combine information from present-day species with fossil data in a Bayesian phylogenetic framework. We apply the method to body mass estimates of a large number of extant and extinct mammal species, and find strong support for Depéret’s rule. The tendency for size increase appears to be driven not by evolution toward larger size in established species, but by processes related to the emergence of new species. Our analysis shows that complementary data from extant and extinct species can greatly improve inference of macroevolutionary processes. [Body size; Cope’s rule; macroevolution; paleontology; phylogenetics.]

Body size is a key ecological trait, and it is relatively easy to measure in present day as well as fossil organisms. Hence, a substantial literature exists on the ecology and evolution of body size in a wide variety of taxa. A long-standing question regarding body size is whether there exists an evolutionary tendency for body size increase, either passive (*sensu* [McShea 1994, 2000](#); see also [Stanley 1973](#)), or active, driven by possible ecological advantages associated with large body size.

The (perceived or real) evolutionary tendency for body size increase is often referred to as “Cope’s rule” or the “Cope rule”, attributing the idea to Edward Drinker Cope, and especially his 1886 book “The Origin of the Fittest”. However, Polly (in Polly and [Alroy 1998](#)) convincingly showed that Cope did not propose this rule—neither in “The Origin of the Fittest” nor in his other writings; this expression was mistakenly introduced into the English literature by [Rensch \(1948\)](#), who was quickly copied by others, such as [Newell \(1949\)](#). However, other authors did propose such a rule early on, most notably Charles [Depéret \(1907\)](#) in his book “Les transformations du monde animal”, later translated into English ([Depéret 1909](#)) under the title “The transformations of the animal world”, in which an entire chapter (pp. 193–205), entitled “the law of increase in size in phyletic branches”, deals with this topic. In this chapter, Depéret stated (pp. 199–200) that this law was “one of the most curious and, from its generality, most important, which has been brought to light by the researches of modern paleontologists” ([Depéret 1909](#), p. 193). Later on in the chapter (pp. 204–205), he raises the question of possible cases of reduction

in body size, as in the so-called “dwarf elephants” of various Mediterranean islands or in the hippopotamus from Madagascar, before concluding that they instead represent the last survivors of lineages that had retained a small body size throughout their evolutionary history. (Incidentally, more recent research has upheld the conclusion that these do represent cases of miniaturization; see [Poulakakis et al. 2006](#); [Orlando et al. 2007](#)). Thus, Depéret believed that body size increase was prevalent, to the point that he doubted that we had demonstrated any cases of gradual body size reduction in any lineage (p. 204). We therefore suggest from now on to refer to an evolutionary tendency for body size increase not as Cope’s rule, but as Depéret’s rule.

Most studies investigating Depéret’s rule have been based on fossil remains (e.g., [Gingerich 1974](#); [Jablonski 1997](#); [Alroy 1998](#); [Laurin 2004](#); [Heim et al. 2015](#)). While evolution is sometimes best described as a random walk (e.g., [Jablonski 1997](#)), some taxa appear to show a tendency for size increase, such as Mesozoic dinosaurs ([Hone et al. 2005](#); [Benson et al. 2014](#)), and planktonic foraminifera, at least between biological crises ([Arnold et al. 1995](#)). In particular in the case of placental mammals (or subclades thereof), paleontologists have long claimed that body size generally increased through the Cenozoic ([Depéret 1907](#); [MacFadden 1986](#); [Alroy 1998](#); [Smith et al. 2010](#); [Raia et al. 2012](#); [Slater et al. 2012](#); [Slater 2013](#); [Saarinen et al. 2014](#)), although exact patterns of body size vary with taxa and periods (e.g., [MacFadden 1986](#); [Alberdi et al. 1995](#); [Finarelli and Flynn 2006](#)), and this complexity in body size evolution patterns is of course not restricted to mammals (e.g., [Laurin 2004](#); [Hone](#)

et al. 2005). Research about the possible explanations of these evolutionary patterns is still in its infancy, but recent progress has been made (e.g., Smith et al. 2010; Lovegrove and Mowoe 2013).

A smaller number of studies used present-day species to test for Depéret's rule. Pianka (1995) studied body sizes of present-day varanid squamates on a phylogeny and found no evidence for a general increase in size. Knouft and Page (2003) similarly analyzed nine present-day families of freshwater actinopterygians, and because large-bodied species tended to represent basal lineages, inferred that if any trend existed, it was toward small rather than large body size. Moen (2006) analyzed body sizes of present-day cryptodiran turtles on a phylogeny, and found no evidence for general size increase. Even in mammals, where paleontological studies concluded that Depéret's rule applies (Alroy 1998; Smith et al. 2010; Raia et al. 2012), Monroe and Bokma (2010) found no evidence for it from extant species. However, by assuming that rates of body size evolution differ between species, Baker et al. (2015) did find evidence for Depéret's rule from extant mammals.

Evidently, the most fruitful approach to investigate evolutionary trends in body size is to combine information on body masses available from present-day species with fossil information about the body masses of their ancient relatives (Finarelli and Flynn 2006; Slater et al. 2012; Finarelli and Goswami 2013). Integration of fossil and present-day data has been hampered by lack of appropriate methods (but see Slater et al. 2012). Here, we present a Bayesian approach to test for a directional trend in the evolution of a metric trait (body mass), using fossil and present-day data on a phylogeny. We apply our approach to a partly resolved phylogeny of mammals (Bininda-Emonds et al. 2007) and body mass data for 3253 present-day (Smith et al. 2003) and 553 extinct species to test for Depéret's rule, and to investigate the importance of using fossil data in this type of analysis.

METHODS

To evaluate evidence for Depéret's rule, we analyze body masses of extant and extinct species of mammals on a phylogeny, modeling evolution as a Brownian motion process along the branches of the phylogeny. The Bayesian algorithm we used (Bokma 2008a) and its modification to test for Depéret's rule (Monroe and Bokma 2010) have been presented before. Therefore, we describe here only its general features, and focus on modifications, especially the incorporation of fossil information. The primary variables of our model are (i) the phylogeny, (ii) the body masses of all the lineages in the phylogenetic tree at the present (i.e., extant species) and at each divergence (internal node) in the reconstructed phylogeny, and (iii) the rates of body mass evolution, including a possible tendency for size increase or decrease.

Because the algorithm is Bayesian, initial values of these variables are sampled from their prior

distributions (that will be described below). Subsequently, these values are iteratively updated using Metropolis or Metropolis–Hastings sampling (Metropolis et al. 1953) so as to construct a Monte Carlo Markov chain (MCMC) that describes their posterior distribution. The structure of the algorithm is as follows:

1. Assign initial values to all variables.
2. Update the topology of polytomies.
3. Update branch lengths of branches that were part of polytomies.
4. Update the rate of evolution s^2 .
5. Update the tendency for size increase or decrease d .
6. Update the body masses at all nodes of the phylogeny.
7. Repeat steps 1–5 many times.

We determined that MCMC chains converged by visually inspecting MCMC chains from repeated analyses with different initial values. About 10,000 iterations after a burn-in of 1000 were sufficient to estimate posterior distributions. We retained every 10th iteration of the chains, that is $10,000/10 = 1000$ samples. Below we describe the priors and likelihood functions used to update the values of the variables.

Priors on Body Mass

Even though extant species can be directly observed and their body masses measured, we are not certain about their average body masses due to sampling effects. We obtained body masses from the compilation by Smith et al. (2003). This compilation provides estimates of species' average body masses, but not of the uncertainty around these estimates. Many studies have shown that body masses of individuals in a population or species of mammals very generally follow a normal distribution. The coefficient of variation of individual body masses around the population mean is very approximately 15% (e.g., McKellar and Hendry 2009). If we take a random sample of n individuals to estimate the mean, then the error variance of that estimate will be $(15\%)^2/n$. Evidently, the error is smaller for larger n . Therefore, we assumed that the averages reported by Smith et al. (2003) are based on only one individual, which yields a variance around the averages of $0.15^2/1 = 0.0225$. This is also the variance around the mean body mass on a logarithmic scale (i.e., because if $x \propto N(1, v)$ then if $v \ll 1$, to a good approximation $\ln x \propto N(0, v)$). The majority of averages reported by Smith et al. (2003) was probably based on more than one individual, so this yields relatively wide priors on the body masses of observed extant species.

For extinct species, we inferred body mass using previously established inference models taken from the literature and from skeletal measurements of fossil material. In several cases, inferences were taken directly from the literature. The body mass was thus inferred or compiled for 553 extinct mammal species ranging in geological age from the Late Jurassic (Oxfordian) to the Pleistocene, but most paleontological data date from the Cenozoic. The compilation also includes the geological age (online Supplementary Data File S1, available on Dryad at <http://dx.doi.org/10.5061/dryad.4nd2j>), determined as accurately as possible. Typically, this is at a lower level than epoch, and using the land mammal ages. The compilation also includes the phylogenetic position (online Supplementary Data File S2, available on Dryad at <http://dx.doi.org/10.5061/dryad.4nd2j>), for which we tried to select the most consensual interpretation from the recent literature, although this exercise is necessarily a bit subjective. When the phylogeny is not consensual or poorly resolved, we inserted polytomies to reflect this uncertainty. The tips of the branches were adjusted to reflect the geological age of the fossils of each taxon. The length of the branches subtending the extinct taxa is unknown because the age of the last common ancestor of various extinct or extinct and extant taxa is unknown. However, given the richness of the mammalian fossil record, it is reasonable to assume that most branches were fairly short (except when other fossils imply long ghost lineages). Thus, we adjusted the terminal branches subtending extinct species to occupy at least 1 myr and the internal branches to occupy at least 0.5 myr, while ensuring that the resulting nodal ages were compatible with all previously established molecular ages and with the fossil record. We did not try to spread evenly the length of branches between nodes subtending extinct and extant taxa (those for which one daughter branch leads to an extinct taxon, and the other, to an extant one) between successive nodes for which molecular dates were available, because in many cases this would have resulted in long branches lacking direct paleontological evidence. Instead, we set branch lengths so that the implied divergence dates between extinct taxa appear plausible from a paleontological point of view. Thus, for instance, the plesiadapiforms that we included into our study date from the Danian (*Purgatorius unio*, at 64 Ma) to the Ypresian (*Microsypops annectens*, at 47 Ma), but given the number of sampled species (29) and these branch length settings, this implied that their last common ancestor lived in the Campanian (about 73 Ma), which will probably appear old enough to most paleontologists. This procedure is admittedly a fairly arbitrary, imprecise exercise, but we know of no other simple solution that could be implemented with reasonable effort on such a large data set. Less arbitrary methods exist (e.g., Bapst 2013), but they would be time-consuming to implement and would presumably have a negligible impact on our results because fossils are pruned at a fairly early stage of the analysis (see below). For each taxon or set of taxa, the data (body mass, geological age, and phylogenetic

position) were compiled by a paleomammalogist, each of which contributed as follows: LC, 91 “condylarth”, perissodactyl, and cetartiodactyl species; OM, 96 glires, lipotyphlan, and chiropteran species; SP, 16 early carnivoran species; EG, 65 Jurassic to Eocene therian species; FS, 70 carnivoran species; SL, 96 marsupial and xenarthran species; and MG, 125 plesiadapiform and primate species. ML centralized the data and built the timetree (with some help from FJ) according to these data, and in consultation with the paleomammalogists. These body mass estimates of extinct species and the phylogenetic tree we used are available at <http://dx.doi.org/10.5061/dryad.4nd2j>.

Even though we have estimates of the body masses of very many extant and extinct species, there remain many clades of which we do not have body mass estimates of extinct species. In addition, the fossils for which we have body size estimates will generally not be the direct ancestors of present-day species. However, we do have prior hypotheses also about the body masses of the unobserved ancestral and present-day species. Typically, we assume that the body mass of an ancestral species very approximately equals the body mass of the present-day species that descended from it. Similarly, we assume that the body mass of an unmeasured extant species very approximately equals the body size of its ancestor, and hence of its extant relatives. Thus, it would not be appropriate to assign missing body masses of lineages a uniform prior $<-\infty, \infty>$. Instead, it seems more appropriate to assign these lineages a normal prior $N(a, v)$. In the following sections we describe how we determined appropriate values for a and v .

Our prior assumption about the body mass of an ancestral species is, as mentioned, roughly equal to the mean body mass of the extant species that descended from it. That, however, is a simplification: our inferences about the ancestor to humans and chimps are also affected by knowledge of the body masses of gorillas and orangutans. Moreover, if estimates of body masses of extinct species are also available, these too affect our prior hypotheses. Thus, it is more appropriate to say that our prior belief of the body mass of a particular species, a , equals the average body mass of all other species (ancestor, descendant, sister, or more distant relative), weighted by their phylogenetic distance to that particular species. Let \mathbf{P} be a square matrix of phylogenetic distances between all species, that is, $1/\exp(b)$ where b is a matrix of summed branch lengths between species pairs. Let \mathbf{M} be a vector of body masses of all species, with zeros for the species that have not been measured, and let \mathbf{A} be a vector of our body mass estimates a . The product $\mathbf{A} = \mathbf{MP}/\Sigma\mathbf{P}$ yields estimates of a for all species, measured as well as not measured (Cheverud et al. 1985) (Σ indicates summation over rows and ensures that \mathbf{A} has the same scale as \mathbf{M}). A similar approach was used by Slater et al. (2012). For the species that were measured, we can plot estimated body size a against measured body size m , which shows that this procedure yields quite accurate predictions ($m_{\text{pred}} = 0.96m_{\text{obs}} + 0.22$,

$r^2 = 0.95$; Supplementary Fig. S1, available on Dryad at <http://dx.doi.org/10.5061/dryad.4nd2j>).

Evidently, the discrepancy between m and a is smaller for species with measured close relatives, and worse for species that appear isolated on the phylogeny. This leads to the question of what is an appropriate variance v for the priors on ancestral body masses. To infer appropriate v for every node in the tree, we made use of the concept of Fisher information: the second derivative of the likelihood function at its maximum. At the maximum of the likelihood function, its first derivatives are of course zero. The second derivatives measure how sharp the peak of the likelihood function is: a sharp peak implies that the function is informative, a broad peak that the function is less informative. Because we will model body size evolution as a Brownian motion process, the likelihood functions will be normal distributions. For the normal distribution, the second partial derivative (partial; about the mean) of the likelihood function is the inverse of the variance. We can use this concept to calculate how much information the body mass of descendant Y provides about that of its ancestor X (or *vice versa*).

Let t_{XY} denote the length of the branch between X and Y, and let s^2 be the rate of body mass evolution (as defined in the section *Priors and Likelihood on Rates of Evolution*). Assuming Brownian motion, the body mass of X is then $m_X \propto N(m_Y, s^2 t_{XY})$ and hence the Fisher information that X provides about Y (or *vice versa*) is $1/(s^2 t_{XY})$. In reality, there will be less information available about X, because m_Y itself is not known without error (Supplementary Fig. S2, available on Dryad at <http://dx.doi.org/10.5061/dryad.4nd2j>). Let v_Y denote the prior variance around m_Y . Then, the information about X provided by Y is: $1/(v_Y + s^2 t_{XY})$. In other words, Y provides more information about X if it is known with little error (small v_Y), if the rate of evolution is low (small s^2), and if the branch between the species is short (small t_{XY}). Fisher information has the attractive property of being additive for independent observations. If X has another descendant Z, then the information about X provided by Z is $1/(v_Z + s^2 t_{XZ})$, and independent of the information provided by Y. Therefore, the Fisher information about X provided by its ancestor W and two descendants Y and Z is $1/(v_W + s^2 t_{WX}) + 1/(v_Y + s^2 t_{XY}) + 1/(v_Z + s^2 t_{XZ})$. Accordingly, the estimate of prior variance v_X around m_X becomes $v_X = \{1/(v_W + s^2 t_{WX}) + 1/(v_Y + s^2 t_{XY}) + 1/(v_Z + s^2 t_{XZ})\}^{-1}$.

The information provided by the body size of species X about that of another species Y is limited because body size evolves with rate s^2 . However, the decay of information over time is determined not only by s^2 , but also by prior uncertainty about the strength d of Déperet's rule. However, we chose a relatively high prior expectation ($0.1 \log_e(g)^2$) of the rate of evolution s^2 , so as to obtain relatively wide priors also on the body masses of species that were not observed. As a consequence, the prior variance of d ($0.0075 [\log_e(g)/\text{myr}]^2$) becomes

negligible, and it suffices to calculate prior expectations using just the prior expectation of s^2 .

The principle of Fisher information introduced above describes how information percolates through the phylogeny, but it does not provide an analytical expression to determine the variance v for any particular unobserved species. To determine v for all nodes in the phylogeny, we started by arbitrarily assigning $v = 1000$ to all nodes for which no measurements were available. Subsequently we updated v for every node X using its descendants (Y and Z, not for present-day species) and ancestor (W, not for the root) using the equation above: $v_X = \{1/(v_W + s^2 t_{WX}) + 1/(v_Y + s^2 t_{XY}) + 1/(v_Z + s^2 t_{XZ})\}^{-1}$. After 1000 updates these variances do not noticeably change any more. (Note that for measured species, v was calculated from the measurements and not updated.)

It should be noted that ancient fossil observations are at much shorter distance from the ancestral nodes in the tree compared with present-day species. Therefore, early species have a far greater effect on the prior distribution of the ancestral body size of the deepest nodes than present-day species have (Ané 2008). The first influence is on the prior means: if fossils tend to have small body sizes, this markedly decreases the prior expectation on the mean body sizes of nearby ancestral nodes (Supplementary Fig. S2, available on Dryad at <http://dx.doi.org/10.5061/dryad.4nd2j>). The second effect is on the variance around the mean, which becomes much smaller for deep nodes, due to shorter branches between these nodes and extinct lineages than between deep nodes and present-day species (Supplementary Fig. S2, available on Dryad at <http://dx.doi.org/10.5061/dryad.4nd2j>). Thus, our approach illustrates how fossil and present-day information can be integrated without assuming that the ancient species represent direct ancestors of present-day species.

Importance of Fossil Data

After using all body mass data to determine a and v (i.e., the body mass prior) for every internal and terminal node in the phylogeny, we pruned the phylogeny of lineages that do not lead to present-day descendants. This is necessary, in our method, to partition evolutionary change into a gradual (i.e., anagenetic) and speciation component (see below), because only for extant taxa can all branches be considered to be known; for extinct taxa, the proportion of known branches is not even known with precision, and may vary between clades and periods. Thus, we performed our analyses on the mammalian phylogeny provided by Bininda-Emonds et al. (2007): the fossil information was used only to obtain informative priors on the body sizes of the internal nodes of this phylogeny. This differs from the more common approach to retain the extinct lineages and fit models directly to the combined data, but makes it straightforward to evaluate

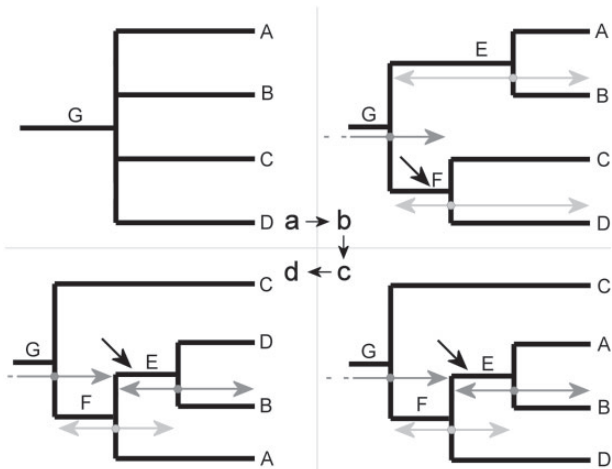

FIGURE 1. Updating of polytomies and branch lengths. Capital A–D are tip species, E, F, and G are internal nodes. Horizontal arrows indicate a node's range of possible branching times. Black arrows indicate the branch around which topology is altered as explained in the main text.

the importance of using fossil information: we repeated our analysis using only the body masses of present-day species.

Prior and Likelihood on Phylogeny

We based our analyses on a phylogeny of present-day mammals (Bininda-Emonds et al. 2007). This phylogeny contains virtually all present-day mammalian species, but also a substantial number of polytomies. We assume a priori that the phylogeny is correct except for the polytomies, and that all possible resolutions of the polytomies are equally likely. We started analyses with randomly resolved polytomies, namely the strictly bifurcating tree provided by Bininda-Emonds et al. (2007). For nodes leading to zero-length branches in the initial tree, our analysis proposes alternative topologies (Fig. 1). Figure 1a shows a polytomy leading to four lineages. This polytomy is first randomly resolved (Fig. 1b). A pair of sister species is randomly selected (in this case E and F). A randomly selected descendant (in this case C) of the lineage that ends earliest (F, indicated with a black arrow) then changes place with the sister lineage that ends latest (E), resulting in Figure 1c. Assuming this proposal is accepted (see next two paragraphs), in the next iteration a pair of sisters is again randomly selected (in this case E and D), and a randomly selected descendant (A) of the one that ends earliest (E, indicated with a black arrow) changes place with the one that ended most recently (D), leading to the tree in Figure 1d. Using this algorithm, all alternative configurations of the species can be reached from the original random resolution of the polytomy.

All alternative topologies are considered *a priori* equally likely, but the body size data may favor some over others. That is in the first place because topological changes affect putative ancestor–descendant pairs, and

hence body size changes. In addition, topological changes make some branches shorter (e.g., branch E from Fig. 1b,c), and other branches longer (e.g., branch C from Fig. 1b,c). This change in branch length also affects the likelihood of the change in body size over the branch. Thus, a proposed topology change affects the likelihood of body size changes over the branches involved, which are used to either accept or reject a proposed topology change using Metropolis sampling. (Note that while a topological change affects the lengths of individual branches, it does not affect branching times of the phylogeny. For example, in Figure 1b, c, and d branching times are identical.)

Not only topology but also branch lengths should be updated to resolve polytomies. Updating of branch lengths is achieved by updating the times of the nodes that in the original tree were the origin and/or end point of zero-length branches. For any such node, we proposed a new time from a uniform distribution between the node from which it originated, and the oldest node that descends from it (if any) (Fig. 1). (Otherwise it would be necessary to also change the times of other nodes.) Whether or not the proposal is accepted depends on two likelihood functions. The first likelihood function stems from the speciation–extinction process that generated the phylogeny. We assume that this process can be modeled as a constant-rates speciation–extinction process (Raup et al. 1973). The likelihood of the branching times of the reconstructed phylogeny (i.e., the phylogeny pruned of extinct species) was derived by Nee et al. (1994) and Stadler (2010) (see also Harvey et al. 1994; Gernhard 2008), but to update individual branching times it is more convenient to use the (equivalent) equations provided by Maddison et al. (2007), because these give the likelihood contribution for each individual branch. (We somewhat arbitrarily assumed that the speciation rate is 0.15 and the extinction rate 0.1 per lineage and per million years, as these values have hardly any effect on the results.) The other likelihood function used in updating branching times is the likelihood of body size changes: updating the time of a node affects the lengths of the branch leading to the node, and the two branches descending from it. Therefore, also the likelihoods of the body size changes over these branches are affected, and these differences in likelihood were also used to accept or reject the proposed change in branch length. In a strictly bifurcating tree the nodes can be divided into two non-overlapping groups (indicated in Fig. 1 by dark and light gray) so that the likelihoods of the proposed new branching times of the members of a group are mutually independent. Dividing the branching times in these two groups, combined with the use of Maddison et al. (2007)'s likelihood, allows for efficient “block updating” of unknown branching times.

Priors and Likelihood on Rates of Evolution

Body size evolution on the phylogeny is modeled as a Brownian motion process with intrinsic rate s^2

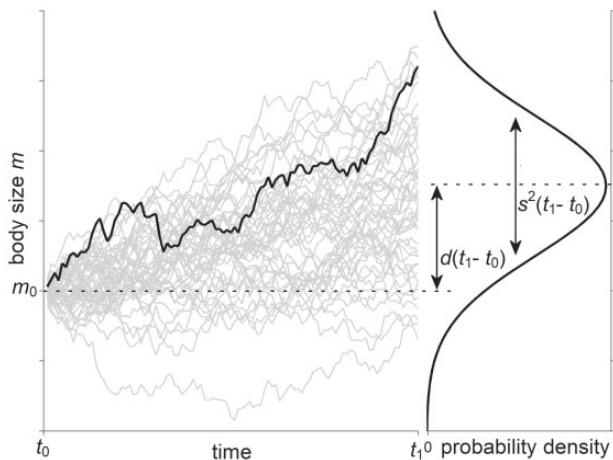

FIGURE 2. Illustration of evolution of body size by directional Brownian motion. Natural logarithmic body size of a species, which is m_0 at time t_0 follows at time t_1 a normal distribution with mean $d(t_1 - t_0)$ and variance $s^2(t_1 - t_0)$. s^2 is the intrinsic rate of Brownian motion, and d is the strength of Depéret's rule. One trajectory of body size change is shown in bold, and 100 equally probable alternative trajectories in gray.

and drift d (Fig. 2): Consider a species with average natural logarithmic body mass $m_0=0$ at time t_0 . After unit time, the body mass of this same species can be considered a random variate drawn from a normal distribution with mean d and variance s^2 . In other words, the likelihood that the species has size m_1 at time t_1 equals the probability density at $m_1 - m_0$ of the normal distribution with mean $d(t_1 - t_0)$ and variance $s^2(t_1 - t_0)$. If s^2 is large, body mass evolves quickly, and if s^2 is small it evolves slowly. In the absence of an overall tendency for size increase (or decrease), $d=0$. Depéret's rule implies that $d > 0$, whereas $d < 0$ would indicate a tendency for body size to decrease. The objective of this study is to distinguish whether $d > 0$, that is, whether there is evidence for Depéret's rule.

Because the rate of body size evolution s^2 is strictly a variance (Fig. 2), we assigned it an exponential distribution as prior, reflecting that s^2 cannot be negative. Based on previous studies that estimated s^2 in mammals (Mattila and Bokma 2008), we decided that a prior mean of $0.1 (\log_e(g)/\text{myr})^2$ would be appropriate. (This mean implies 10% change in body size per myr, which is higher than estimates in the literature, and therefore yields a relatively broad prior.) We assigned the tendency for body size increase d a normal prior with mean 0. Thus, the prior neither assumes nor excludes Depéret's rule ($d > 0$), and also does not exclude a tendency for decrease ($d < 0$). It is difficult to determine the variance around this mean, because estimates of the strength of Depéret's rule in literature are sparse and highly variable. We decided that a variance of $0.0075 (\log_e(g)/\text{myr})^2$ was appropriate. This is admittedly rather wide, as it does not exclude rates of size increase that appear quite improbable, but a narrower variance would assign relatively low likelihood to, for example, Alroy's (1998) high estimate of d , which

could be deemed inappropriate as it is based on rather extensive data. In any case, the sheer number of species analyzed here should provide so much information about d that choosing a wide prior introduces negligible bias.

Earlier studies of mammalian body size evolution indicated that body size evolves not only gradually over time as assumed above, but also in rapid bursts that appear associated with speciation (Mattila and Bokma 2008), a phenomenon that occurs in many clades and periods, to which Eldredge and Gould (1972) drew attention. Furthermore, Heim et al.'s (2015) analysis of marine animals indicated that Depéret's rule does not stem from evolution toward larger size in established species, but from differential proliferation of lineages. Therefore, we also investigated whether Depéret's rule is manifested in gradual evolution over time in established species, or in rapid evolution in incipient species, or both. For this investigation we complemented the model of Brownian motion over time (above, with parameters d and s^2) with rapid change in incipient species: we assume that when a new species emerges, the difference in $\log_e(\text{body mass})$ with its immediate ancestor $m_{\text{desc}} - m_{\text{anc}}$ is normally distributed with mean d_c and variance s_c^2 . (The subscript c denotes cladogenesis, and we assume that cladogenetic change is effectively instantaneous on a geological time scale so that d_c and s_c^2 are independent of time.) We assigned d_c a normal prior with zero mean and variance 0.1, and s_c^2 an exponential prior with mean 0.1.

In order to accurately estimate changes in body size in incipient species (i.e., d_c and s_c^2), we must estimate how many internal nodes have been pruned of the phylogeny by extinction. Under the assumption that the process that led to the phylogeny can be modeled as a constant-rates speciation–extinction process (Raup et al. 1973), we can estimate the number of pruned speciation events on every branch of the reconstructed tree—that is, the phylogeny of extant species pruned of all extinct lineages (Bokma et al. 2012). To do that, we pruned the phylogeny of extinct lineages, and used the branching times of the phylogeny to estimate the rates of speciation and extinction (Bokma 2008b). These rates were then used to estimate numbers of pruned speciation events. Estimation of the rates of speciation and extinction and numbers of hidden speciation events is achieved by inserting these estimation steps into the MCMC framework outlined above (Bokma 2008a; Mattila and Bokma 2008; Monroe and Bokma 2010). When rates of speciation and extinction and numbers of hidden speciation events are estimated, longer MCMC chains are needed to sample the posterior: after a burn-in of 50,000 we sampled every 500th of 500,000 samples.

Note that modifying the method to directly accommodate extinct species (from the fossil record) would require obtaining a random sample of the known extinct species (which we currently do not have, as the taxonomic sample reflects the field of expertise of the paleomammalogists who participated in the

compilation). It would also require making additional hypotheses, such as postulating a fairly homogeneous fossilization potential of lineages through time and between clades, and assuming that we have accurate divergence times between extant and even extinct taxa (Stadler 2010; Didier et al. 2012), which may not be realistic.

Model Comparison

In order to test for Depéret's rule, we want to compare the support of the data for a model with Depéret's rule ($d > 0$) to the support for a model without trend ($d = 0$). Because the estimation of d and the other unknown parameters is Bayesian, it is most straightforward to test for Depéret's rule using Bayes factor, K :

$$K = \frac{p(y|M_0)}{p(y|M_1)} = \frac{\int p(\vartheta_0|M_0)p(y|\vartheta_0,M_0)d\vartheta_0}{\int p(\vartheta_1|M_1)p(y|\vartheta_1,M_1)d\vartheta_1},$$

where y is data, and θ are the parameters of model M . Bayesian analyses often approximate the posterior distributions of θ using a Markov Chain, and in the field of phylogenetics this is virtually always the case. These studies also often approximate the marginal likelihoods $p(y|M)$ needed to calculate K as the harmonic mean of the likelihoods of the MCMC chain (e.g. Monroe and Bokma 2010; Slater et al. 2012). However, it is notoriously difficult to calculate K from a Markov chain of samples of θ (Weinberg 2012). Fortunately, however, the model without trend (where $d = 0$) can be regarded as a special case of the more general model allowing for Depéret's rule (where d can take any value, including zero). Therefore, we may write for the model without Depéret's rule $p(y|\vartheta = \vartheta_0, M_1)$. Substituting this into the definition of Bayes factor we obtain:

$$K = \frac{p(y|M_0)}{p(y|M_1)} = \frac{p(y|\vartheta = \vartheta_0, M_1)}{p(y|M_1)} = \frac{p(y|\vartheta = \vartheta_0)}{p(y)}.$$

If we apply Bayes theorem, we can rewrite the numerator in the above equation as:

$$p(y|\vartheta = \vartheta_0) = \frac{p(\vartheta = \vartheta_0|y)p(y)}{p(\vartheta = \vartheta_0)}.$$

Substituting this in the equation for Bayes factor, we finally obtain:

$$K = \frac{p(\vartheta = \vartheta_0|y)}{p(\vartheta = \vartheta_0)}.$$

This illustrates that we can calculate Bayes factor as the ratio of the prior density at $d = 0$ to the posterior density at $d = 0$. This ratio of the prior to the posterior at $\theta = \theta_0$ is known as the Savage–Dickey ratio (Dickey 1971; Morey et al. 2011). Thus, we can measure the evidence in the data for a tendency for body size increase by comparing the prior and posterior densities of $d = 0$. This is conceptually and computationally substantially easier than alternative methods (Weinberg 2012).

RESULTS

When disregarding the paleontological data on body masses, so that only body masses of extant species are analyzed, we estimate that the intensity of Depéret's rule is $d = 0.0014 \log_e(g)/\text{myr}$ (std. = 0.0011; Fig. 3). This would imply that species become on average 0.14% larger during a million years of evolution. A kernel density estimate of the posterior probability density at $d = 0$ is 164.3. We assigned d a normal prior distribution with zero mean and variance $0.0075 [\log_e(g)/\text{myr}]^2$. According to this prior, the density at $d = 0$ is 4.61. As argued above, because the model without Depéret's rule is a special case of the more general model that allows Depéret's rule (namely the case where $d = 0$), we may calculate Bayes factor as the ratio of posterior to prior density at $d = 0$. This yields an estimate of Bayes factor of $K = 164.3/4.61 = 35.7$, which on Jeffery's scale indicates that the data provide very strong evidence against Depéret's rule. This result is similar to that obtained in a previous study (Monroe and Bokma 2010), which used a similar method to analyze largely similar data, but somewhat different priors, and a different method to calculate Bayes factor.

If we take into account the fossil information on body mass, the results are very different. Now we estimate $d = 0.0078 \log_e(g)/\text{myr}$ (std. = 0.0012), which implies that on average a lineage increases 0.78% in body size during a million years. The posterior density at $d = 0$ when fossil information is taken into account becomes 1.62×10^{-51} . This value is much lower than the prior density at $d = 0$, which was 4.61. Consequently, Bayes factor becomes $K = 1.62 \times 10^{-51}/4.61 = 3.52 \times 10^{-52}$. On Jeffery's scale, this implies that the data provide decisive evidence in favor of Depéret's rule.

The posterior density was estimated using kernel density estimation, which may be imprecise in the tails of the distribution, where $d = 0$ is located in this case. However, Figure 3 shows that the posterior distribution of d is a good approximation of a normal distribution. An alternative approach to estimate the posterior density thus is to calculate its mean (0.0078) and standard deviation (0.0012) from the MCMC samples, and to assume its distribution is normal. Doing so yields a posterior density at $d = 0$ of 1.1×10^{-7} , which compared with the prior density of 4.61 yields a Bayes factor of 2.40×10^{-8} , indicating decisive evidence for Depéret's rule. Thus, although the exact value obtained for Bayes factor depends on whether posterior density is estimated using kernel methods or normal approximation, the data evidently decisively favor Depéret's rule over unbiased evolution.

Because the incorporation of fossil data into the analysis has such a profound impact on the results, we also investigated whether the estimate of d depends on how much fossil data is used. We randomly selected 500, 400, 300, 200, 100, 50, 25, and 10 of the fossil body size estimates, and estimated d , twice for each of these sample sizes (Fig. 4). For small samples of fossil body mass estimates, estimates of d tend to zero. The increase

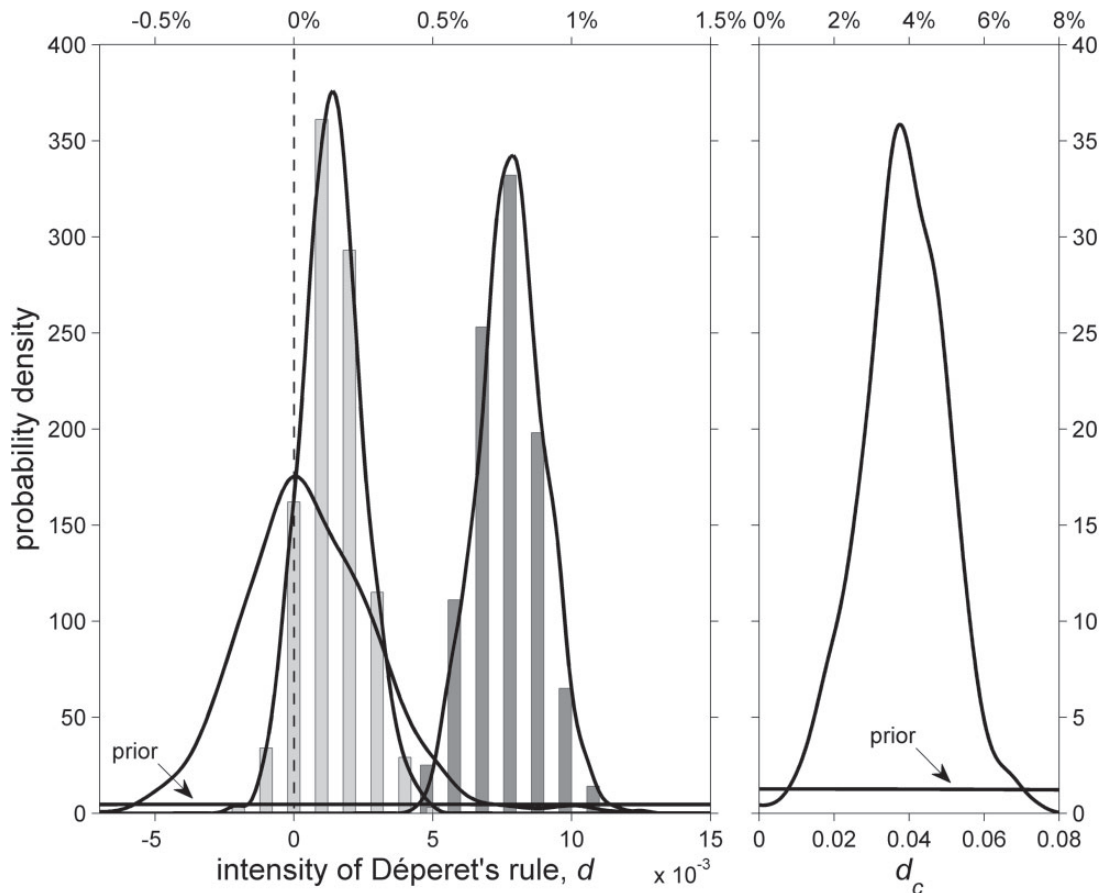

FIGURE 3. Prior and posterior distributions of the tendency for body size increase d . The horizontal axis at the top shows proportional change (% body size increase per myr) on an ordinary scale. Posterior distributions of MCMC samples are expressed as probability density, calculated using kernel density estimation. (Histograms serve as illustration only.) Note that because the prior distribution has much greater variance than the posterior distributions, its probability density is much lower than the peaks of the posterior distributions. Left panel: d estimated without fossil information (light gray bars), with fossil information (dark gray bars), and the gradual component of d (no bars), estimated with fossil information alongside with the cladogenetic component d_c (shown only on the right panel). Right panel: prior and posterior distribution of d_c . Note that Bayes factor is calculated as the ratio of prior to posterior at $d=0$ (vertical dashed line), where the posterior obtained without fossil information (light gray bars) has far higher density than the prior, while the posterior obtained with fossil evidence (dark gray bars) has much lower density than the prior.

of d with sample size suggests that the value of d that would be estimated if all extinct lineages were observed would be very roughly $d = 1\%/myr$.

Anagenetic and Cladogenetic Contributions

So far we assumed that body mass evolution occurs gradually over time along the branches of the phylogeny. However, previous analyses indicated that a large proportion of body size differences between mammalian species are due to rapid changes associated with speciation events (Mattila and Bokma 2008). We therefore complemented our model: incipient species instantaneously differ in $\log_e(\text{body size})$ from their ancestor by an amount that is normally distributed with mean d_c and variance s_c^2 . (The subscript c denotes “cladogenetic.”) To account for speciation events that are pruned from the reconstructed phylogeny by extinction, we also estimated the speciation and extinction rates.

Because the additional parameter d_c accounts for part of the overall tendency for size increase, the estimate of d decreases when it is estimated along with d_c : When we assumed that evolution was purely gradual we estimated $d = 0.0078 \log_e(g)/myr$ (above), but when also d_c is estimated, we obtain $d = 5.98 \times 10^{-4} \log_e(g)/myr$ and $d_c = 0.038 \log_e(g)/\text{speciation event}$. These estimates imply that over a million years of evolution a lineage increases on average 0.06% in body size, and over a single speciation event on average 3.8%. In the reconstructed phylogeny of extant species, the average period of gradual change following a single case of cladogenetic change is λ^{-1} , where λ is the speciation rate. Over this period of time the tendency toward size increase is $d_c + d/\lambda$. Substituting our estimates of $d_c = 0.038$, $d = 5.98 \cdot 10^{-4}$, and $\lambda = 0.20$, we estimate that a descendant becomes on average 4.1% larger than its ancestor in about 5 myr. Alroy (1998) estimated 9% and Baker et al. (2015) 6%. Of this overall tendency toward size increase,

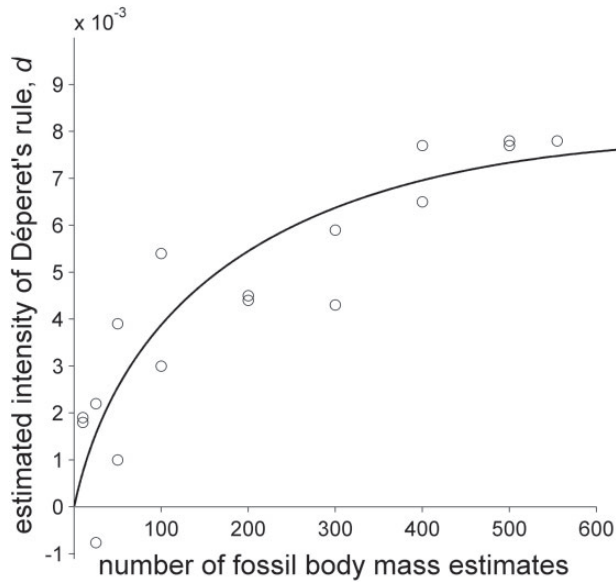

FIGURE 4. Estimates of the strength of Depéret's rule, d , as a function of the number of fossil body mass estimates. We randomly sampled 10, 25, 50, 100, 200, 300, 400, and 500 of the fossil body mass estimates, and estimated d . We did this twice, so for every number of species two estimates of d are shown. The estimate using all 553 fossil estimates is also shown. (Standard deviations around these estimates are approximately 0.0011, independent of the number of fossil species sampled, and therefore not shown.) Trendline by eyeballing.

the fraction f_d that is due to cladogenetic change is $f_d = d_c / (d_c + d / \lambda)$. Again substituting our estimates of d_c , d , and λ we obtain $f_d = 93\%$, suggesting that Depéret's rule is almost exclusively due to cladogenesis.

DISCUSSION

Our analysis provides evidence of Depéret's rule in mammalian body size evolution. In addition, it indicates that the tendency for body size increase is not due to gradual increase over time in established species, but associated with cladogenesis. In our model cladogenetic size change, that is, the logarithmic size difference between an incipient species and its immediate ancestor is normally distributed with mean d_c . Our finding that $d_c = 0.038 \log_e(g)/\text{myr}$ could therefore indicate that novel species tend to be larger than their ancestor soon after they originate. Alternatively, it may indicate that among descendant lineages, larger-bodied species are more likely to proliferate, as has been suggested for marine animals (Heim et al. 2015). Baker et al. (2015) assumed that rates of evolution differ between species, but did not model cladogenetic change. It is possible that species appear to evolve at different rates because phylogenetic branches differ stochastically in the number of speciation events pruned by extinction (Bokma et al. 2012), and hence in the number of instances of cladogenetic evolution.

Our study confirms the pivotal role of fossil data to test for long-term evolutionary trends (Finarelli and Flynn 2006; Slater et al. 2012; Finarelli and Goswami 2013): we estimated no tendency for body size increase using data

from 3253 extant mammalian species, but when we added 553 fossil lineages (or even a subsample of just 100) we found decisive evidence for Depéret's rule. The great value of fossil data is intuitive: consider a stochastically increasing line, and two points along this line. The further these points are apart, the more informative their position will be about the slope of the line. In the limit, if the two points coincide they provide no information about the slope. Consequently, not all fossil observations are equally informative about directional evolution. Therefore, specimens should not be randomly selected for analysis: if selection is necessary it should maximize the number of independent, accurately inferred long-term ancestor–descendant differences. This will often mean preferential inclusion of fossil specimens whose phylogenetic position is close to the base of crown clades with a sufficient number of measured present-day species.

If body size evolution is modeled as Brownian motion as is the case here, then the covariance between extant species is expected to be proportional to their shared evolutionary history (Cavalli-Sforza and Piazza 1975; Cheverud et al. 1985; Felsenstein 1985; Pagel 1997). Because all present-day species are at the same distance from the root of their phylogeny, a trend toward larger size does not affect the covariance structure, and hence there is no power to detect Depéret's rule from present-day species alone (Pagel 1997; Laurin 2010). To test for directional evolution one must place the present-day species at variable distances from the root. One way to achieve this is to assume that evolution is concentrated in speciation events and that we know about all these events, or at least, a representative sample thereof, because not all present-day species are separated from the root by the same number of speciation events. Knouft and Page (2003) used this approach in their study of freshwater actinopterygians. An alternative approach is to assume that trait evolution is proportional to genetic distance rather than time, because also genetic distance to the root typically varies somewhat across extant species. Moen (2006) used this approach in his study of turtles. However, neither approach yields high statistical power when applied to a limited data set of present-day species only. Yet another approach is to assume that rates of evolution differ between branches of the phylogeny. Baker et al. (2015) made this assumption in their analysis of mammals, and did find evidence of Depéret's rule.

In the light of the evidence in favor of Depéret's rule that we obtained using fossil information, the most surprising result is perhaps the strong evidence against Depéret's rule that we obtained when disregarding fossil information. As explained above, because we assumed evolution by Brownian motion, present-day species alone should provide no information about directional evolution, which implies that the posterior of d should be essentially identical to the prior. This phenomenon has already been observed in other evolutionary issues, such as the estimation of extinction rates from molecular phylogenies (Paradis 2004). This is not what we found: the clear discrepancy between the posterior and the prior

seen in Figure 1 is therefore almost certainly due to the prior distributions on the body sizes at the internal nodes of the phylogeny. Each node was assigned a prior that, although wide, peaks at the value expected in the absence of Depéret's rule. Together, these priors on body mass apparently *induce* a prior on d that is substantially different from the prior that we *assigned* to d . This is a problem that is hard to overcome: any prior assigned to ancestral body sizes would affect the posterior of d . It is important, however, to be aware of these effects.

We calculated Bayes factor as the Savage–Dickey ratio, that is, the ratio of posterior to prior at $d = 0$. The primary reason for this was that estimating marginal likelihoods from MCMC samples of the likelihood, for instance by harmonic mean approximation (Monroe and Bokma 2010; Slater et al. 2012) is notoriously unreliable. The Savage–Dickey ratio also helps to illustrate the crucial role of the prior on d : if much data are analyzed, the posterior is determined almost exclusively by the data, and not by the prior. (Fig. 4 shows that that is the case here.) With the posterior largely fixed by the data, the Savage–Dickey ratio, and hence Bayes factor, effectively depends on the choice of prior. It should be remembered that even though the Savage–Dickey ratio is calculated from the prior and posterior distribution of d , it still is a ratio of marginal likelihoods, as we showed by deriving it from the general expression for Bayes factor. Thus, calculating Bayes factor from marginal likelihoods obtained in some other way will not alter the crucial role of the prior. In the present study, the choice of prior on d was somewhat arbitrary. It is therefore important to point out that any prior on d reasonably wider than the posterior, and also the prior on d that was induced through the priors on ancestral body masses, would have led to the same conclusion: that mammalian body size tended to increase over time.

In summary, our study confirms the pivotal role that fossil data can play for macroevolutionary inferences (Finarelli and Goswami 2013). Slater et al. (2012) demonstrated this using simulations, and also demonstrated that in Bayesian analyses fossil data can be incorporated into informative priors. We introduced a method to obtain informative priors using Fisher information, and showed how Bayes factor is calculated as the Savage–Dickey ratio. Our study further illustrates the usefulness of Bayesian phylogenetic analyses, but it also shows that complex Bayesian analyses are not free of problems: care should be taken in interpreting the results. Still, we find strong evidence for Depéret's rule in mammals, ostensibly driven by cladogenetic processes.

SUPPLEMENTARY MATERIAL

Data available from the Dryad Digital Repository: <http://dx.doi.org/10.5061/dryad.4nd2j>.

FUNDING

This work was supported by the CNRS and the French ministry of research through the recurring grant to the

CR2P, and from the Swedish research council Formas [grant 215-2012-1372 to F.B.].

ACKNOWLEDGMENT

We thank David Polly, Graham Slater, and the editors for their critical and constructive comments.

REFERENCES

- Alberdi M.T., Prado J.L., Ortiz-Jaureguizar E. 1995. Patterns of body size changes in fossil and living Equini (Perissodactyla). *Biol. J. Linn. Soc.* 54:349–370.
- Alroy J. 1998. Cope's rule and the dynamics of body mass evolution in North American fossil mammals. *Science* 280:731–734.
- Ané C. 2008. Analysis of comparative data with hierarchical autocorrelation. *Ann. Appl. Stat.* 2:1078–1102.
- Arnold A.J., Kelly D.C., Parker W.C. 1995. Causality and Cope's rule: Evidence from the planktonic Foraminifera. *J. Paleontol.* 69:203–210.
- Baker J., Meade A., Pagel M., Venditti C. 2015. Adaptive evolution towards larger size in mammals. *Proc. Natl. Acad. Sci. U. S. A.* 112:5093–5098.
- Bapst D.W. 2013. A stochastic rate-calibrated method for time-scaling phylogenies of fossil taxa. *Methods Ecol. Evol.* 4:724–733.
- Benson R.B.J., Frigot R.A., Goswami A., Andres B., Butler R.J. 2014. Competition and constraint drove Cope's rule in the evolution of giant flying reptiles. *Nat. Commun.* 5:3567.
- Bininda-Emonds O.R.P., Cardillo M., Jones K.E., MacPhee R.D.E., Beck R.M.D., Grenyer R., Price S.A., Vos R.A., Gittleman J.L., Purvis A. 2007. The delayed rise of present-day mammals. *Nature* 446:507–512.
- Bokma F. 2008a. Detection of "punctuated equilibrium" by Bayesian estimation of speciation and extinction rates, ancestral character states, and rates of anagenetic and cladogenetic evolution on a molecular phylogeny. *Evolution* 62:2718–2726.
- Bokma F. 2008b. Bayesian estimation of speciation and extinction probabilities from (in)complete phylogenies. *Evolution* 62:2441–2445.
- Bokma F., Van den Brink V., Stadler T. 2012. Unexpectedly many extinct hominins. *Evolution* 66:2969–2974.
- Cavalli-Sforza L., Piazza A. 1975. Analysis of evolution: Evolutionary rates, independence, and treeness. *Theor. Popul. Biol.* 8:127–165.
- Cheverud J.M., Dow M.M., Leutenegger W. 1985. The quantitative assessment of phylogenetic constraints in comparative analyses: Sexual dimorphism in body weight among primates. *Evolution* 39:1335–1351.
- Depéret C. 1907. *Les transformations du monde animal*. Paris: Flammarion.
- Depéret C.J.J. 1909. *The transformations of the animal world*. London: Kegan Paul, Trench, Trübner & Company, Limited 359 p.
- Dickey J.M. 1971. The weighted likelihood ratio, linear hypotheses on normal location parameters. *Ann. Math. Stat.* 42:204–223.
- Didier G., Royer-Carenzi M., Laurin M. 2012. The reconstructed evolutionary process with the fossil record. *J. Theor. Biol.* 315:26–37.
- Eldredge N., Gould S.J. 1972. Punctuated equilibria: An alternative to phyletic gradualism. In: Schopf T.J.M., editor. *Models in paleobiology*. San Francisco: Freeman, Cooper & Company p. 82–115.
- Felsenstein J. 1985. Phylogenies and the comparative method. *Am. Nat.* 125:1–15.
- Finarelli J.A., Goswami A. 2013. Potential pitfalls of reconstructing deep time evolutionary history with only extant data, a case study using the canidae (Mammalia, Carnivora). *Evolution* 67:3678–3685.
- Finarelli J.A., Flynn J.J. 2006. Ancestral state reconstruction of body size in the Caniformia (Carnivora, Mammalia): The effects of incorporating data from the fossil record. *Syst. Biol.* 55:301–313.
- Gernhard T. 2008. The conditioned reconstructed process. *J. Theor. Biol.* 253:769–778.
- Gingerich P. 1974. Stratigraphic record of early Eocene Hypsodus and the geometry of mammalian phylogeny. *Nature* 248:107–109.
- Harvey P.H., May R.M., Nee S. 1994. Phylogenies without fossils. *Evolution* 48:523–529.

- Heim N.A., Knope M.L., Schaal E.K., Wang S.C., Payne J.L. 2015. Cope's rule in the evolution of marine animals. *Science* 347:867–870.
- Hone D.W.E., Keesey T.M., Pisani D., Purvis A. 2005. Macroevolutionary trends in the Dinosauria: Cope's rule. *J. Evol. Biol.* 18:587–595.
- Jablonski D. 1997. Body-size evolution in cretaceous mollusks and the status of Cope's rule. *Nature* 385:250–252.
- Knouft J., Page D. 2003. The evolution of body size in extant groups of North American freshwater fishes: Speciation, size distributions, and Cope's rule. *Am. Nat.* 161:413–421.
- Laurin M. 2004. The evolution of body size, Cope's rule and the origin of amniotes. *Syst. Biol.* 53:594–622.
- Laurin M. 2010. Assessment of the relative merits of a few methods to detect evolutionary trends. *Syst. Biol.* 59:689–704.
- Lovegrove B.G., Mowoe M.O. 2013. The evolution of mammal body sizes: Responses to Cenozoic climate change in North American mammals. *J. Evol. Biol.* 26:1317–1329.
- MacFadden B.J. 1986. Fossil horses from "Eohippus" (*Hyracotherium*) to *Equus*: Scaling, Cope's law, and the evolution of body size. *Paleobiology* 12:355–369.
- Maddison W.P., Midford P.E., Otto S.P. 2007. Estimating a binary character's effect on speciation and extinction. *Syst. Biol.* 56:701–710.
- Mattila T.M., Bokma F. 2008. Extant mammal body masses suggest punctuated equilibrium. *Proc. Roy. Soc. Lond. B* 275:2195–2199.
- McKellar A.E., Hendry A.P. 2009. How humans differ from other animals in their levels of morphological variation. *PLoS One* 4:e6876.
- McShea D.W. 1994. Mechanisms of large-scale evolutionary trends. *Evolution* 48:1747–1763.
- McShea D.W. 2000. Matters of the record. *Paleobiology* 26:330–333.
- Metropolis N., Rosenbluth A.W., Rosenbluth M.N., Teller A.H., Teller E. 1953. Equations of state calculations by fast computing machines. *J. Chem. Phys.* 21:1087–1092.
- Moen D.S. 2006. Cope's rule in cryptodiran turtles: Do the body sizes of extant species reflect a trend of phyletic size increase? *J. Evol. Biol.* 19:1210–1221.
- Monroe M.J., Bokma F. 2010. Little evidence for Cope's rule from Bayesian phylogenetic analysis of extant mammals. *J. Evol. Biol.* 23:2017–2021.
- Morey R.D., Rouder J.N., Pratte M.S., Speckman P.L. 2011. Using MCMC chain outputs to efficiently estimate Bayes factors. *J. Math. Psychol.* 55:368–378.
- Nee S., Holmes E.C., May R.M., Harvey P.H. 1994. Extinction rates can be estimated from molecular phylogenies. *Phil. Trans. R. Soc. Lond. B* 344:77–82.
- Newell N.D. 1949. Phyletic size increase, an important trend illustrated by fossil invertebrates. *Evolution* 3:103–124.
- Orlando L., Pagés M., Calvignac S., Hughes S., Hänni C. 2007. Does the 43 bp sequence from an 800 000 year old Cretan dwarf elephantid really rewrite the textbook on mammoths? *Biol. Lett.* 3: 58–60.
- Pagel M. 1997. Inferring evolutionary processes from phylogenies. *Zool. Scr.* 26:331–348.
- Paradis E. 2004. Can extinction rates be estimated without fossils? *J. Theor. Biol.* 229:19–30.
- Pianka E.R. 1995. Evolution of body size: Varanid lizards as a model system. *Am. Nat.* 146:398–414.
- Polly P.D., Alroy J. 1998. Cope's rule. *Science* 282:50–51.
- Poulakakis N., Parmakelis A., Lymberakis P., Mylonas M., Zouros E., Reese D.S., Glaberman S., Caccone A. 2006. Ancient DNA forces reconsideration of evolutionary history of Mediterranean pygmy elephantids. *Biol. Lett.* 2:451–454.
- Raia P., Carotenuto F., Passaro F., Fulgione D., Fortelius M. 2012. Ecological specialization in fossil mammals explains Cope's rule. *Am. Nat.* 179:328–337.
- Raup D.M., Gould S.J., Schopf T.J.M., Simberloff D.S. 1973. Stochastic models of phylogeny and the evolution of diversity. *J. Geol.* 81: 525–542.
- Rensch B. 1948. Histological changes correlated with evolutionary changes of body size. *Evolution* 2:218–230.
- Saareinen J.J., Boyer A.G., Brown J.H., Costa D.P., Ernest S.M., Evans A.R., Fortelius M., Gittleman J.L., Hamilton M.J., Harding L.E. 2014. Patterns of maximum body size evolution in Cenozoic land mammals: Eco-evolutionary processes and abiotic forcing. *Proc. Roy. Soc. Lond. B* 281:1–10.
- Slater G.J. 2013. Phylogenetic evidence for a shift in the mode of mammalian body size evolution at the Cretaceous–Palaeogene boundary. *Methods Ecol. Evol.* 4:734–744.
- Slater G.J., Harmon L.J., Alfaro M.E. 2012. Integrating fossils with molecular phylogenies improves inference of trait evolution. *Evolution* 66:3931–3944.
- Smith F.A., Boyer A.G., Brown J.H., Costa D.P., Dayan T., Ernest S.K.M., Evans A.R., Fortelius M., Gittleman J.L., Hamilton M.J., Harding L.E., Lintulaakso K., Lyons S.K., McCain C., Okie J.G., Saareinen J.J., Sibly R.M., Stephens P.R., Theodor J., Uhen M.D. 2010. The evolution of maximum body size of terrestrial mammals. *Science* 330: 1216–1219.
- Smith F.A., Lyons S.K., Ernest S.K.M., Jones K.E., Kaufman D.M., Dayan T., Marquet P.A., Brown J.H., Haskell J.P. 2003. Body mass of late Quaternary mammals. *Ecology* 84:3403.
- Stadler T. 2010. Sampling-through-time in birth–death trees. *J. Theor. Biol.* 267:396–404.
- Stanley S. 1973. An explanation for Cope's rule. *Evolution* 27: 1–26.
- Weinberg M.D. 2012. Computing the Bayes factor from a Markov chain Monte Carlo simulation of the posterior distribution. *Bayesian Anal.* 7:737–770.