



# Review in isothermal amplification technology in food microbiological detection

Xiang Li<sup>1,2,3</sup> · Xiaolong Zhang<sup>1</sup> · Xiaoli Shi<sup>1</sup> · Hongfei Shi<sup>1</sup> · Zhouping Wang<sup>2,3</sup> · Chifang Peng<sup>2,3</sup>

Received: 13 April 2022 / Revised: 16 August 2022 / Accepted: 21 August 2022 / Published online: 13 September 2022  
© The Korean Society of Food Science and Technology 2022

## Abstract

Food-borne diseases caused by microbial contamination have always been a matter of great concern to human beings. Hence, the research on these problems has never stopped. With the development of microorganism amplification technology, more and more detection methods have come into our vision. However, traditional detection technologies presents more or less drawbacks, such as complicated operation, low accuracy, low sensitivity, long-time detection, and so on. Therefore, more convenient, accurate, and sensitive measurement for the microorganism are needed. Isothermal amplification technology is one of the alternative approach containing the above mentioned advantages. This work mainly summarizes the principles of loop-mediated isothermal amplification (LAMP) and rolling circle amplification (RCA) which belong to isothermal amplification. Meanwhile, the application of LAMP and RCA in food microorganism detection is introduced.

**Keywords** Food safety · Isothermal amplification · LAMP · RCA · Microorganism · Analytical method

## Introduction

Food is essential to life, and food safety is closely related to every one of us. Billions of people in the world are at risk of unsafe food, and millions become sick while hundreds of

thousands die yearly. Historically, chemical pollutants are one kind of the crucial risk in most food safety incidents. Microbial contamination has become an increasing cause in the twenty-first century (Fung et al., 2018). Accordingly, microbial detection technology is also in continuous development. The traditional detection technology commonly used in the past is morphological detection technology, which is observed through electron microscope and microscope after the culture of microorganisms. The colony of microorganisms is distinguished according to the color, shape and other biochemical indexes of the colony, and the colony number of the plate is calculated with the low cost. On the contrary, the drawbacks of long time, rich experience and skills of experimenter, and inaccuracy of the technology limited its extensive application. Therefore, this traditional method will be gradually eliminated in food detection with the development of society and the application of new detection technology (Swaminathan and Feng, 1994). Nowadays, diverse food microbiological detection methods have been studied not only in pursuit of accurate results but also in order to improve efficiency or reduce the detection limit, such as immunology technology, protein chip technology, biosensor technology, molecular biology detection technology and so on. The immunological detection methods are helpful measurements with high flux and short time, but false-positive results and high requirements for the quality

---

✉ Xiang Li  
lixiang@njucm.edu.cn

Xiaolong Zhang  
1033798152@qq.com

Xiaoli Shi  
2788773536@qq.com

Hongfei Shi  
925056955@qq.com

Zhouping Wang  
wangzp@jiangnan.edu.cn

Chifang Peng  
pcf@jiangnan.edu.cn

<sup>1</sup> Nanjing University of Chinese Medicine, Xianlin Rd 138, Nanjing 210046, Jiangsu, People's Republic of China

<sup>2</sup> School of Food Science & Technology, Jiangnan University, Lihu Rd 1800, Wuxi 214122, Jiangsu, People's Republic of China

<sup>3</sup> State Key Lab of Food Science & Technology, Jiangnan University, Lihu Rd 1800, Wuxi 214122, Jiangsu, People's Republic of China

of antibodies confine their common applications (Wang et al., 2020). Protein chip technology is to use the functional proteins fixed on the carrier to capture the target proteins that can specifically bind to the chips, and then detect them. Despite the advantages of high flux and high sensitivity, the chips need high requirements for antibody and chip production (Cahill, 2001). Biosensors can analyze the species of microorganisms by detecting the spectra of complex samples, but the sensitivity of the biosensors needs to be further developed (Palchetti and Mascini, 2008). Among them, analytical biological detection technology has been widely used in food microbial detection because of its high sensitivity and specificity. Among them, the most important one is polymerase chain reaction (PCR) detection technology, its derivative technology and isothermal amplification technology. The main methods of PCR and its derivation are polymerase chain reaction (PCR), multiplex PCR (mPCR), real-time quantitative PCR (qPCR), reverse transcription PCR (RT-PCR). The main methods of isothermal amplification are loop-mediated isothermal amplification (LAMP) and rolling circle isothermal amplification (RCA), etc. The application of conventional PCR technology in food microbiological detection is generally used to detect a variety of foodborne microorganisms at the same time and to identify the isolated and purified microorganisms. However, although the conventional PCR technology is the most widely used method due to its low-cost, it can only be applied in gene amplification. Subsequent gene analysis needs the help of electrophoresis technology (Hanada, 2020), fluorescence detection technology (Mackay, 2004) or sequencing technology (Shen et al., 2021) to achieve the final detection goal. Based on conventional PCR, qPCR is a method to quantitatively and qualitatively analyze the initial template by adding a fluorescence signal to the reaction system and then using the instrument to monitor the signal. Although the cost of equipment is relatively high, this method present the advantages of high automation, labor-saving, high specificity and accuracy (Singh and Roy-Chowdhuri, 2016; Gadkar and Fillion, 2014; Harshitha and Arunraj, 2021). The application of mPCR technology, mainly by adding a variety of primers to the detection system, can meet the requirements of one-time detection of a variety of pathogens, and has the advantages of rapid and efficient detection. However, the use of mPCR techniques needs to take into account the sensitivity to avoid errors in the test results (Chang et al., 2021; Markoulatos et al., 2002; Settanni and Corsetti, 2007). RT-PCR is often used to detect RNA virus contamination in food, such as novel coronavirus (Thompson et al., 2021). However, the application of this method becomes minority, and it is generally only used in the detection of viruses with RNA as genetic material, and other microbial tests are not applicable to this method (Singh and Roy-Chowdhuri, 2016). Although PCR is still the most widely used technology for nucleic acid

amplification, due to its need for thermal cycle amplification instruments and complex amplification procedures, these shortcomings make the field application of PCR difficult and lead to an increase in the cost of screening. In contrast, isothermal amplification technology shows a wider range of applications for the original biological samples, and the efficiency of clinical diagnosis is better than PCR technology. The isothermal amplification technology exhibited advantages from sample processing to subsequent detection, which only needs to be carried out in a tubule with a small number of samples achieving rapid detection (Chang et al., 2012). Therefore, LAMP has been developed by leaps and bounds in recent years. This paper mainly discusses the general principles of LAMP and RCA technologies, as well as their application and research advance in the detection of food microorganisms by combining them with other technologies.

## LAMP in food microbial detection

### Principle of LAMP

LAMP is a novel isothermal nucleic acid amplification method developed by Japanese scholar Notomi et al. (2000) in 2000. LAMP technique uses two pairs of specially designed primers (Fig. 1) to provide the reaction power by using the chain replacement activity of BstDNA polymerase to amplify the target DNA at a constant temperature. The

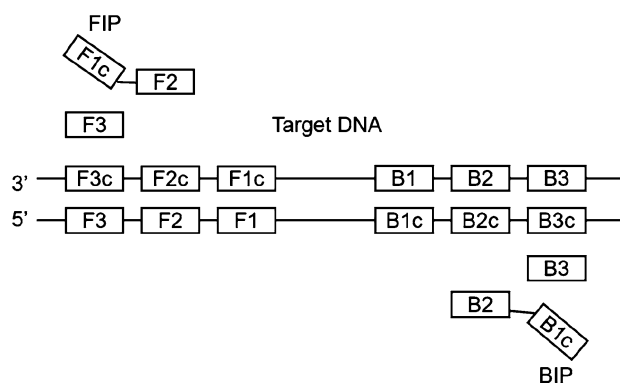

**Fig. 1** The LAMP primer consists of a pair of internal primers (FIP and BIP) and a pair of external primers (F3 and B3), in which FIP is composed of F1c and F2 and BIP is composed of B1c and B2. FIP primer: upstream internal primers, is composed of F2 region, which is complementary to F2c region at the 3' end of the target gene and identical to the F1c region at the 5' end of the target gene. F3 primer: upstream external primer, is composed of F3 region and complementary to F3c region of the target gene. BIP primer: downstream internal primers, is composed of B2 region, which is complementary to the B2c region at the 3' end of the target gene and the same sequence as the B1c region at the 5' end of the target gene. B3 primer: downstream external primers, is composed of B3 region and complementary to the B3c region of the target gene

key to the reaction lies in the formation of the stem-ring structure. The inner primers bind to the complementary sequence of the stem-ring structure and synthesize extension and chain placement under the action of BstDNA polymerase (Fig. 2). Since there is no annealing and renaturation process of conventional PCR, the reaction can be carried out at a constant temperature.

The overall principle of LAMP is more or less the same, but in order to attain the high efficiency, wide scope and so on, future generations have made many improvements on its basis. In the aspect of primer design, Nagamine et al. (2002) creatively designed a pair of ring primers LoopF/LoopB between F1c-F2c/B1c-B2c, which greatly shortened the time of LAMP reaction, and the whole amplification reaction could be completed in 0.5 h. However, the non-specific pairing between ring primers can lead to false-positive results. Zyrina et al. (2007) and others also tried to explain this phenomenon. Nowadays, there have been many primer design software to facilitate manual alignment to

find primers, such as Primer Explorer V4, LAVA, BioSun LAMP and so on. But at the same time, manual analysis, screening and adjustment are still needed to minimize or prevent non-specific amplification. In the detection of amplified products, when the open tube detection methods such as electrophoresis are used, it is easy to make the product aerosol overflow and pollute the experimental environment, resulting in false positives. To solve this problem, Mori et al. (2004) designed a real-time turbidity detection device to close the tube to detect magnesium pyrophosphate precipitation. However, because the instrument is expensive, it is difficult to popularize and use it at the grass-roots level. Later, several groups solved the problem by adding indicators or stains (Tomita et al., 2008; Goto et al., 2009; Tao et al., 2011). In 2008, Njiru et al. (2008) added fluorescent dye SYTO-9 to the LAMP amplification system and realized the real-time monitoring of LAMP amplification by using a real-time fluorescence PCR instrument. The development of real-time fluorescence quantitative LAMP detection will

**Fig. 2** LAMP reaction includes three stages: dumbbell template synthesis stage, cyclic amplification stage and elongation and recycling stage, whose key program is the formation of the stem-ring structure. The inner primers bind to the complementary sequence of the stem-ring structure and synthesize extension and chain placement under the action of BstDNA polymerase

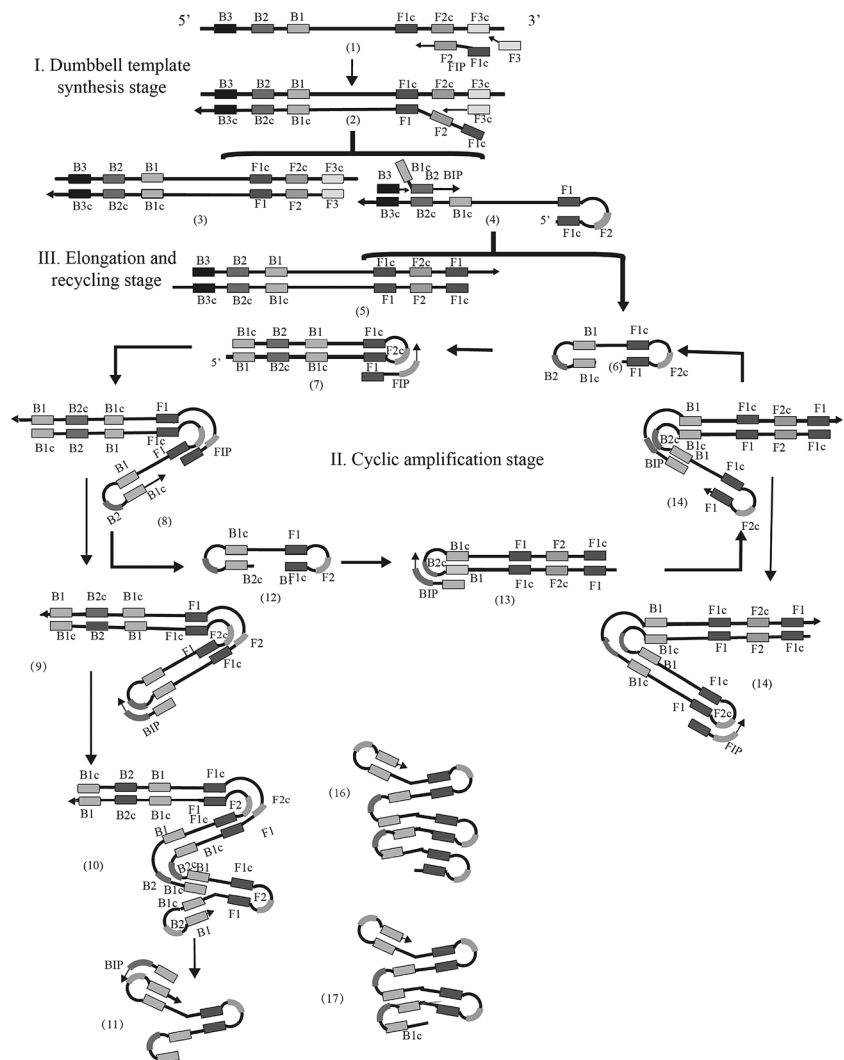

also be described in detail below. Some people complete the closed tube reaction by solid paraffin sealant. Thus it can be seen that the solutions to the relevant principle problems are constantly being improved. Thus it can be seen that the principle is the foundation, but the related optimization still needs the joint efforts of generations of researchers.

### Application of LAMP in food microbial detection

LAMP is widely applied in plant disease detection, animal disease detection, food safety detection and so on (Notomi et al., 2015). LAMP is constantly being optimized and developing in different areas.

In plant disease, it mainly detects fungi, bacteria, viruses and so on. As an example of plant virus's detection, the LAMP has been greatly improved in terms of virus types and detection sensitivity (Panno et al., 2020). The first LAMP detection method for plant virus was established by Fukuta et al. (2004) in 2004, which was used for the detection of tomato spotted wilt virus. At present, LAMP detection techniques have been developed for 20 species of plant quarantine viruses and 1 species of plant quarantine viruses belonging to 12 genera at home and abroad.

In animal disease, it mainly detects viruses, bacteria, parasites and so on. Take virus detection as an example, Pham et al. (2005) applied RT-LAMP technology to the diagnosis of animal diseases for the first time, which is the most commonly used method for virus detection, and established a LAMP method for the detection of Newcastle disease virus, which could be used for the rapid diagnosis of *Newcastle disease virus* infection. The discovery of a new type of OmniAmp DNA polymerase (POL) is an important innovation of RT-PCR, which replaces DNA polymerase (Bst) and reverse transcriptase to realize the single enzyme detection of target RNA, which makes RT-PCR more promising in virus detection (Chander et al., 2014). POL has more advantages than traditional RT-LAMP polymerase and is more suitable for virus diagnosis in a harsh environment, which lays a foundation for the portable development of LAMP.

The application of LAMP technology in the field of food safety detection mainly includes detection of food microorganisms, detection of genetically modified foods, detection of food adulteration, detection of food allergens and so on. Among them, the earliest application of LAMP technology in the field of food analysis is the detection of foodborne pathogens. At the end of the twentieth century, there were a large number of cases of food poisoning caused by foodborne pathogens at home and abroad. Taking enterohemorrhagic *Escherichia coli* (EHEC) as an example, food poisoning caused by this bacteria first broke out in the United States in 1982, and then cases were found all over the world, including China. In 2003, Maruyama et al. (2003) described a new in situ DNA amplification technique for microscopic

detection of bacteria carrying a specific gene. LAMP was used to detect *stxA(2)* in *Escherichia coli* O157:H7 cells. The mild permeabilization conditions and low isothermal temperature used in the in situ LAMP method caused less cell damage than in situ PCR. It allowed the use of fluorescent antibody labeling in the bacterial mixture after the DNA amplification for identification of *Escherichia coli* O157:H7 cells with a *stxA(2)* gene. Higher-contrast images were obtained with this method than with in situ PCR. This is perhaps the earliest application of LAMP technology in the field of food microbiological detection. This study explains why they began to try to apply LAMP technology to the field of food microbiology. There are two main reasons. First, the Notomi team published the research results of LAMP in 2000. Second, the previously widely used situ PCR show some obvious shortcomings. In this report, the LAMP reaction was adapted to reduce background while amplifying a specific gene inside the cell. Fluorescent antibody labeling was also applied to identify specific cells and examine the reliability of in situ LAMP. Simultaneous visualization of a functional gene and surface antigen was carried out by both in situ LAMP and situ PCR for comparison. In addition, this study also discussed the problem of optimizing the permeability conditions of a gene in situ amplification and the result shown that embedding samples in the gel before in situ LAMP enables enumeration of bacterial cells carrying specific genes in a natural environment without diffusing amplified products outside the cell or causing species—selective cell loss and destruction in mixed microbial communities. In addition to *Escherichia coli*, LAMP is also widely used in foodborne pathogens such as *Salmonella*, *Staphylococcus aureus*, *Listeria monocytogenes*, *Vibrio parahaemolyticus* and so on (Srisawat and Panbangred, 2015; Yin et al., 2016; Tang et al., 2011; Lee et al., 2020).

As a result, the application of LAMP in food microbiological detection is more and more abundant, and the update and combination of various technologies are more and more diversified, such as the development of Real-time fluorescent loop-mediated isothermal amplification (RealAmp), Visual LAMP, Immunomagnetic Separation Loop-mediated Isothermal Amplification Technique (IMS-LAMP), Reverse Transcriptional Loop-mediated Isothermal Amplification Technique (RT-LAMP) and Multiplex LAMP Technique, which will be explained next.

### Research process of LAMP in food microbial detection

#### RealAmp in food microbial detection

LAMP technology can achieve real-time fluorescence quantification through the principle that the fluorescence group was added to the reaction system, and the whole process was

monitored in real-time by the accumulation of fluorescence signals and finally, the position template was quantitatively analyzed by the standard curve, so many researchers will develop equipment to achieve the purpose of collecting signals and achieving high throughput.

Compared with real-time PCR method, RealAmp has the improved specificity and sensitivity. Ye et al. (2015) compared RealAmp with the API Listeria and real-time PCR assays to detect *Listeria*. All 58 *L. monocytogenes* strains from different countries were detected by the RealAmp assay, whereas only 57 (98.3%) and 56 (96.6%) strains were identified as *L. monocytogenes* by the API Listeria and PCR assays respectively, thereby demonstrating that it has a higher specificity and sensitivity than conventional identification assays.

In addition to comparing with other technologies, RealAmp itself is also improving. For example, Wang (2016) designed new amplification primers to make the detection limit of real-time fluorescent LAMP for *S. aureus* in food to be 10 fg DNA template/reaction, which is more sensitive than previous studies.

However, there are still some problems to be solved in the technological development of RealAmp. Because there are many substances in the food matrix that affect molecular amplification, such as fat, protein and enzyme in meat, they all inhibit the efficiency of amplification and affect the sensitivity. Therefore, at present, most of the rapid detection techniques need to improve the pre-enrichment protocol, which will reduce the testing time (Opet and Levin, 2013, 2014; Caplan et al., 2013). However, in 2015, Wu et al. (2015) established a new method, which can greatly reduce the detection time while making the RealAmp method have higher detection sensitivity. They do not carry out a pre-enrichment protocol but use closed activated carbon to treat samples, which greatly shortens the detection time, which is of great significance for the rapid and sensitive detection of pathogenic bacteria in food without pre-enrichment protocol.

### Visual LAMP in food microbial detection

Visualization technology is a technology suitable for rapid, on-site and qualitative detection. At present, visual LAMP technology is mainly divided into two kinds: dye indicator and Lateral flow dipstick (LFD). In 2008, Tomita et al. (2008) proposed for the first time: In LAMP, a large amount of DNA is synthesized, yielding a large pyrophosphate ion by-product. Pyrophosphate ion combines with divalent metallic ion to form an insoluble salt. Adding calcein, a fluorescent metal indicator, to the reaction solution allows visualization of substantial alteration of the fluorescence during the one-step amplification reaction, which takes 30–60 min. In 2009, Goto et al. (2009) added

hydroxy naphthol blue (HNB) as an indicator of the LAMP reaction for the first time. Pre-addition of 120  $\mu$ M HNB to the LAMP reaction solution did not inhibit amplification efficiency. A positive reaction is indicated by a color change from violet to sky blue. The technique of detecting trace antigens established by Sano et al. (1992) is the basis of LFD. LAMP-LFD technology combines molecular biology and immunochromatography. After the end of the LAMP reaction, the test strip is directly inserted into the mixed solution of the buffer and the amplification product for 5–10 min. The biotin-labeled LAMP product is hybridized specifically with the probe labeled by fluorescein isothiocyanate (FITC) to form an immune complex, which is diffused by chromatography and colored by combining with the biotin-resistant detection line on the test strip. The unhybridized probe and antibody form a binary complex, continue to spread and combine with the quality control line to develop color (Kaewphinit et al., 2013).

Although visual LAMP can only be used as a qualitative detection method, compared with PCR, it has obvious advantages in the lowest detection limit, detection time, sensitivity, detection rate and so on. Anupama et al. (2020) established a method for rapid visual detection of *Vibrio parahaemolyticus* in seafood by LAMP with HNB. The assay was carried out on 62 seafood samples that included clam and shrimp and compared with the conventional LAMP assay performed with the commonly used HNB, conventional PCR, and RT-PCR. The HNB-LAMP assay was found to be highly sensitive, specific, and superior to conventional PCR ( $P < 0.05$ ). RT-PCR presented higher sensitivity than HNB-LAMP; however, it has the limitation of being cost-intensive and requiring technical expertise to perform. Besides, Mei et al. (2019) established a LAMP-LFD method for rapid detection of *Salmonella* strains in food samples. Compared with PCR and real-time PCR methods, the LAMP-LFD assay has the same specificity and higher sensitivity and required only 40 min (10 min for LFD detection) at 65°C. All 52 strains of *Salmonella* yielded positive results using the LAMP-LFD assay and showed no cross-reaction with 37 tested non-*Salmonella* strains. The detection limit of the LAMP-LFD assay was 13.5 fg/ $\mu$ l (genomic DNA) and 6.7 CFU/ml (cell), which was 1000-fold more sensitive than conventional PCR and 100-fold more sensitive than real-time PCR. Additionally, the LAMP-LFD method could detect *Salmonella* in artificially contaminated food samples when present as low as 144 CFU/ml or CFU/g and without the use of an enrichment step.

Thus it can be seen that visual LAMP not only has the convenience of rapid detection and naked eye observation, but also has certain advantages in sensitivity, lowest detection limit and detection time.

### IMS-LAMP in food microbial detection

The purpose of immunomagnetic separation technology is to enrich and separate the target bacteria. The principle is to make use of the magnetism of magnetic beads and the characteristics of functional groups that can be modified to combine the modified magnetic beads with microorganisms, and the complex will undergo mechanical transfer under the action of a magnetic field, so as to achieve the rapid separation of microorganisms and maintain the activity of microorganisms. IMS-LAMP is to modify specific antibodies on the surface of immunomagnetic beads, concentrate and isolate the target microorganisms in immunomagnetic beads by antigen–antibody reaction, and then detect them by LAMP technology (Escalante-Maldonado et al., 2015).

Qin et al. (2018) established a rapid and specific detection of *Escherichia coli* O157: H7 in ground beef using IMS-LAMP. The LAMP method results analyzed with real-time turbidity measurements showed high specificity and sensitivity, with a positive detection rate of amplification of EHEC O157: H7 DNA diluted to a minimum equivalent concentration of  $1.8 \times 10^1$  CFU/ml, which was 10 times more sensitive than the conventional PCR assay. The IMS followed with LAMP could capture and detect a bacterial concentration as low as  $3 \times 10^1$  CFU/ml from the meat samples, which was close to the sensitivity of LAMP assay with pure culture.

Thus it can be seen that immunomagnetic beads have unique advantages in the separation and detection of microorganisms, such as strong specificity, high sensitivity, short detection time and low toxicity to microorganisms. However, its application is limited because of its different surface-modified antibodies. The disadvantage of immunomagnetic beads is that their sensitivity is affected by antibody titer, and the specificity of magnetic beads depends on the specificity of antibodies, which will affect the detection effect because of the lower activity of antibodies. Because the specific immunomagnetic beads are connected with monoclonal antibodies, and the production cost of monoclonal antibodies is high, the cost of immunomagnetic beads is also very high, which limits its practical application in microbial detection (Romero et al., 2016).

### RT-LAMP in food microbial detection

RT-LAMP was proposed at the same time as LAMP. Notomi et al. (2000) not only proposed LAMP, but also mentioned that when using reverse transcriptase, the amplification reaction is also suitable for RNA. In that study, they mentioned: “This method (reverse transcription-coupled LAMP) easily detected prostate-specific antigen (PSA) mRNA in one PSA-expressing LNCaP cell mixed with 1,000,000 PSA-negative K562 cells”, which present that RT-LAMP has a

high sensitivity for detecting RNA target genes. Therefore, RT-LAMP entered the field of RNA virus detection.

It is not only specific for RNA virus but also has advantages over other RNA virus detection methods in terms of sensitivity or detection time. Fukuda et al. (2008) developed a two-step isothermal amplification assay system combining nucleic acid sequence-based amplification and RT-LAMP, which achieved the detection of norovirus (NoV) *genomes* in oysters with a sensitivity similar to that of reverse transcription-semi-nested PCR. The time taken for the amplification of NoV *genomes* from RNA extracts was shortened to about 3 h. Xie et al. (2012) developed an RT-LAMP for visual detection of avian reovirus. The detection limit of the RT-LAMP assay was 10 fg total RNA, which was 100-fold lower than that of reverse transcriptase-polymerase chain reactions. The specificity of the assay was supported by the lack of cross-reaction with other avian pathogens. Techathuvan and D’ Souza (2012) established an RT-LAMP method for *Salmonella enterica* detection in liquid whole eggs with results obtainable within 24 h, which is significantly faster than traditional cultural assays.

Thus it can be seen that the RT-LAMP detection scheme designed for different RNA viruses can improve the sensitivity or detection time. The specific aspects of improvement still need to be determined by the specific circumstances. But overall advantages have always been needed as the goal of the development of this technology.

### Multiplex LAMP in food microbial detection

Most of the conventional detection methods of LAMP amplification products are based on double-stranded DNA products or their by-products of polymerization, which can only judge whether amplification occurs or not, but it is difficult to identify the target source and specificity of multiple amplification products. In order to realize the highly specific detection of multiple targets, scholars from various countries have developed a series of multiplex LAMP amplification detection techniques through ingenious improvement or coupling with other technologies.

Generally speaking, multiplex LAMP is mainly used in three aspects: to achieve the combined screening of a variety of targets to be tested; to improve the detection rate of pathogens with large sequence variation and many subclasses, and to introduce reference genes to improve the reliability of diagnosis and detection. And food microbiological detection belongs to the first two kinds. For example, Kasahara et al. (2014) established a multiplex LAMP method for the detection of two types of yeasts that can conditionally cause deep mycosis in dairy products, which promotes the quality and safety control of dairy products. Single-ended mycotoxins on wheat can cause harm due to human and animal consumption of contaminated wheat, and there are many species of

*Fusarium oxysporum* producing these toxins. To monitor the contamination of grain and feed, Denschlag et al. (2014) designed two groups of LAMP primers to amplify different genes of two kinds of *Fusarium*, and combined them to achieve the purpose of rapid and sensitive detection of *Fusarium oxysporum*.

### Prospect and possible technical problems of LAMP

As a new type of nucleic acid amplification technology, LAMP plays an important role in more and more fields as its various advantages are gradually known by researchers. Because of its simple operation, high sensitivity, strong specificity and no need for expensive instruments, it is faster and simpler than other amplification methods. The key of LAMP lies in the design of the four specific primers. For different detection objects, the researchers also use different primers screening and different improvements to LAMP technology. Moreover, LAMP easily causes false positive and pollution. Its product development and other aspects need to be more in-depth research. Through further optimizing and improving this technology, LAMP will play a more and more important role in food microbial detection.

### RCA in food microbial detection

#### The principle of RCA

Rolling circle amplification (RCA) is a nucleic acid amplification technique based on the rolling loop replication of DNA molecules of circular DNA in nature (Mok and Mariani, 1987). It is a DNA amplification technique that occurs at constant temperature. In the mid-1990s, Fire and Xu (1995) at the Carnegie Institute in the United States and Liu et al. (1996) at Stanford University described the principle of RCA successively. In the RCA reaction, when there is a circular DNA template and polymerase, through the action of DNA polymerase, the circular DNA is used as the template to replicate, and finally a DNA single strand of repetitive

sequences complementary to the circular DNA template is formed (Fig. 3).

The most basic RCA includes two forms: linear amplification and exponential amplification. Linear RCA refers to the extension of a primer to cyclic DNA under the action of DNA polymerase, resulting in a linear DNA single strand with a large number of repetitive sequences (completely complementary to cyclic DNA). When linear RCA is used for target nucleic acid amplification, it is limited to viruses, plasmids and circular chromosomes with cyclic nucleic acids, and the length of the rings should be less than 200 bp. Because of its single strand amplification property, one end of the amplification product can always be connected to the primer of the solid phase support, which is very suitable for the detection of local specific signal of the solid phase microarray.

The principle of the exponential RCA technique is the same as that of the linear RCA. On the basis of the linear RCA, a primer is added which is completely consistent with the circular DNA sequence. The primer complements and extends with the partial sequence of the first linear RCA product. At the same time, the primers that were hybridized downstream to other copy segments of the amplification product were removed, and then the replaced extension product could be used as the template of the first primer. In this way, the amount of amplification product increased exponentially in a very short time.

#### Application of RCA

RCA technology has a good application in medical diagnosis, basic research, nanomaterials, food safety detection and so on. In the field of medical diagnosis, RCA can be combined with immune chip technology. The detection and diagnosis of some diseases and the screening of drug targets have been partially optimized by immune chip technology, but the detection with high throughput and high sensitivity is beyond the ability of traditional signal amplification detection. Immune chip detection based on RCA technology not

**Fig. 3** In the RCA reaction, when there is a circular DNA template and polymerase, the circular DNA is used as the template to replicate through the action of DNA polymerase, and finally a DNA single strand of repetitive sequences complementary to the circular DNA template is formed

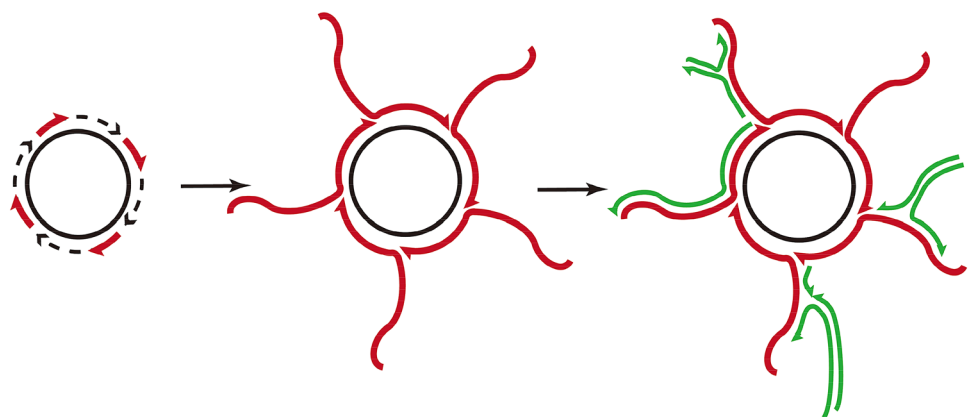

only overcomes this defect, but also ensures the spatial independence of chip targets and the integrity of antigen–antibody binding (Göransson et al., 2012; Bi et al., 2013). In the field of basic research, such as the study of molecular biology, RCA can be well applied to the study of larger annular DNA templates (Bi et al., 2013). In addition, RCA technology has also been extended to pre-genome amplification (Rockett et al., 2015). In the field of nanomaterials, RCA can be used to synthesize specific DNA nanostructures and simulate complex DNA replication in vitro. In the field of food safety detection, RCA is widely used in the detection of food microorganisms, biotoxins, heavy metals, agricultural and veterinary drug residues and so on. In the following content, the specific application of RCA in food microbiological detection will mainly be introduced.

### RCA in food microbial detection

Similar to LAMP, in practical applications, these techniques generally do not appear alone and are usually combined with other technologies. For RCA, it is most often combined with saltatory technology, which is called saltatory rolling circle amplification (SRCA). Under the action of BstDNA polymerase, SRCA technology only needs a pair of primers to amplify the linear template, then "crosses" the gap at the end of the target sequence by adding bases, and replaces the previously synthesized complementary DNA strands to realize the rolling loop circle amplification of linear DNA. When RCA amplifies the linear template, it needs lock probe, ligase and artificial cyclization process, which is complex and time-consuming. By contrast, SRCA technology has the advantages of high amplification efficiency, low economic cost and simple operation.

### SRCA in food microbial detection

Yang et al. (2019) established a SRCA method for the detection of *S. aureus* in milk. The results of the SRCA method can be assessed visually by the presence of white precipitate or by fluorescence measurement. In the detection of pure bacteria, the method by precipitation detected  $7.8 \times 10^1$  fg/ $\mu$ l and the method by fluorescence detected  $7.8 \times 10^0$  fg/ $\mu$ l. In the detection of food sample, the method by precipitation detected  $5.6 \times 10^2$  CFU/ml and the method by fluorescence detected  $5.6 \times 10^1$  CFU/ml. Compared with conventional PCR method, the SRCA assay achieved at least 100-fold

higher sensitivity. Yuan et al. (2020) established a SRCA method for the detection of *Alicyclobacillus acidoterrestris* in apple juice. Similarly, compared with the traditional PCR method, SRCA exhibited at least a 100-fold higher sensitivity and 100-fold lower detection limit. However, the sensitivity of the SRCA method is not necessarily higher than that of the general PCR method. Wang et al. (2018) established a SRCA method for *Shigella* spp. in vegetable salad, whose detection limit was 100-fold lower than that in traditional PCR method. However, the SRCA method has lower economic requirements and is more suitable for use in grass-roots or economically underdeveloped areas. Thus it can be seen that our research on the development of new technology is not limited to higher and stronger, but needs to adapt measures to local conditions and seek more suitable and economical testing methods.

### Prospect and possible technical problems of RCA

As can be seen from the previous article, RCA has rich applications in the field of food microbiological detection. But as a detection technology, it also has some defects. First of all, specificity and sensitivity are always a pair of contradictions perplexing the development of RCA technology. The key to solve this contradiction lies in the efficiency of hybridization and connection between nucleic acid chains. In the study, Banér et al. (2001) found that ligase can also catalyze single-chain link in some cases. Moreover, the connection conditions and efficiency between DNA chains with DNA as template and DNA chains with RNA as template are quite different. At the same time, some studies have discussed the connection efficiency of the lock probe, and there are some solutions. In the aspect of nucleic acid chain hybridization, the hybridization process of DNA and DNA chain and RNA and DNA chain is also different due to the influence of a series of factors such as ion strength, temperature, chain composition and so on. Therefore, the pre-test of condition optimization must be carried out before the experiment to find out the hybridization kinetic curve between different nucleic acid chains, so as to improve the hybridization efficiency as much as possible, so as to further improve the detection sensitivity. In conclusion, with the gradual maturity of RCA technology, the application in food microbial detection will be more mature, as well (Table 1).



**Table 1** The advantages and shortcomings of LAMP and RCA

| Detection methods | Advantages  | Shortcomings   |
|-------------------|---|--|
| <b>LAMP</b>       |   |  |
| RealAmp           | Better specificity and sensitivity  | Pre-enrichment protocol may need more time (but can be solved by using closed activated carbon to treat samples) |
| Visual LAMP       | Convenience of rapid detection and naked eye observation, but also has certain advantages in sensitivity, lowest detection limit and detection time               | A kind of qualitative test, quantitative research cannot be carried out  |
| IMS-LAMP          | Strong specificity, high sensitivity, short detection time and low toxicity to microorganisms   | Their sensitivity is affected by antibody titer  |
| RT-LAMP           | The RT-LAMP detection scheme designed for different RNA viruses can improve the sensitivity or detection time   | Different schemes need to be designed for different RNA viruses  |
| Multiplex LAMP    | Achieve the combined screening of a variety of targets to be tested and improve the detection rate of pathogens with large sequence variation and many subclasses | The detection limit and sensitivity may not be as good as the separate detection method                          |
| <b>RCA</b>        |   |  |
| SRCA              | Lower economic requirements and is more suitable for use in grass-roots or economically underdeveloped areas  | Poorer detection limit, sensitivity or other aspects   |

**Acknowledgements** This work was supported by the department of education of Jiangsu province, China (20KJD310002), CAS “Light of West China” Program (2020XBZG-XBQNXZ-A) and the Innovation Foundation of University in Gansu Province (2021A-123).

## Declarations

**Conflict of interest** The authors declare no conflict of interest.

## References

- Anupama KP, Nayak A, Karunasagar I, Maiti B. Rapid visual detection of *Vibrio parahaemolyticus* in seafood samples by loop-mediated isothermal amplification with hydroxynaphthol blue dye. *World Journal of Microbiology and Biotechnology*. 36(5): 76 (2020)
- Banér J, Nilsson M, Isaksson A, Mendel-Hartvig M, Antson DO, Landegren U. More keys to padlock probes: mechanisms for high-throughput nucleic acid analysis. *Current Opinion in Biotechnology*. 12(1): 11-15 (2001)
- Bi S, Zhao T, Luo B, Zhu JJ. Hybridization chain reaction-based branched rolling circle amplification for chemiluminescence detection of DNA methylation. *Chemical Communications*. 49(61): 6906-6908 (2013)
- Cahill DJ. Protein and antibody arrays and their medical applications. *Journal of Immunological Methods*. 250(1-2): 81-91 (2001)
- Caplan Z, Melilli C, Barbano DM. Gravity separation of fat, somatic cells, and bacteria in raw and pasteurized milks. *Journal of Dairy Science*. 96(4): 2011-2019 (2013)
- Chander Y, Koelbl J, Puckett J, Moser MJ, Klingele AJ, Liles MR, Carrías A, Mead DA, Schoenfeld TW. A novel thermostable polymerase for RNA and DNA loop-mediated isothermal amplification (LAMP). *Frontiers in Microbiology*. 5: 395 (2014)
- Chang CC, Chen CC, Wei SC, Lu HH, Liang YH, Lin CW. Diagnostic devices for isothermal nucleic acid amplification. *Sensors*. 12(6): 8319-8337 (2012)
- Chang LJ, Hsiao CJ, Chen B, Liu T-Y, Ding J, Hsu W-T, Su-Ortiz V, Chen S-T, Su K-Y, Wu H-P, Lee C-C. Accuracy and comparison of two rapid multiplex PCR tests for gastroenteritis pathogens: a systematic review and meta-analysis. *BMJ Open Gastroenterology*. 8(1): e000553 (2021)
- Denschlag C, Rieder J, Vogel RF, Niessen L. Real-time loop-mediated isothermal amplification (LAMP) assay for group specific detection of important trichothecene producing *Fusarium* species in wheat. *International Journal of Food Microbiology*. 177: 117-127 (2014)
- Escalante-Maldonado O, Kayali AY, Yamazaki W, Vuddhakul V, Nakaguchi Y, Nishibuchi M. Improvement of the quantitation method for the tdh (+) *Vibrio parahaemolyticus* in molluscan shellfish based on most-probable-number, immunomagnetic separation, and loop-mediated isothermal amplification. *Frontiers in Microbiology*. 6: 270 (2015)
- Fire A, Xu SQ. Rolling replication of short DNA circles. *Proceedings of the National Academy of Sciences*. 92(10): 4641-4645 (1995)
- Fukuda S, Sasaki Y, Seno M. Rapid and sensitive detection of norovirus genomes in oysters by a two-step isothermal amplification assay system combining nucleic acid sequence-based amplification and reverse transcription-loop-mediated isothermal amplification assays. *Applied and Environmental Microbiology*. 74(12): 3912-3914 (2008)
- Fukuta S, Ohishi K, Yoshida K, Mizukami Y, Ishida A, Kanbe M. Development of immunocapture reverse transcription loop-mediated isothermal amplification for the detection of tomato spotted wilt virus from chrysanthemum. *Journal of Virological Methods*. 121(1): 49-55 (2004)
- Fung F, Wang HS, Menon S. Food safety in the 21st century. *Bio-medical Journal*. 41(2): 88-95 (2018)
- Gadkar Vy, Filion M. New Developments in Quantitative Real-time Polymerase Chain Reaction Technology. *Current Issues in Molecular Biology*. 16:1-6 (2014)
- Göransson J, Ke R, Nong RY, Howell WM, Karman A, Grawé J, Stenberg J, Granberg M, Elgh M, Herthnek D, Wikström P, Jarvius J, Nilsson M. Rapid identification of bio-molecules applied for detection of biosecurity agents using rolling circle amplification. *PLoS One*. 7(2): e31068 (2012)
- Goto M, Honda E, Ogura A, Nomoto A, Hanaki K. Colorimetric detection of loop-mediated isothermal amplification reaction by using hydroxy naphthol blue. *Biotechniques*. 46(3): 167-172 (2009)
- Hanada K. Introduction and Perspectives of DNA Electrophoresis. *Methods in Molecular Biology*. 2119: 1-13 (2020)

- Harshitha R, Arunraj DR. Real-time quantitative PCR: A tool for absolute and relative quantification. *Biochemistry and Molecular Biology Education*. 49(5): 800-812 (2021)
- Kaewphinit T, Arunrut N, Kiatpathomchai W, Santiwatanakul S, Jaratsing P, Chansiri K. Detection of *Mycobacterium tuberculosis* by using loop-mediated isothermal amplification combined with a lateral flow dipstick in clinical samples. *Biomed Research International*. 2013: 926230 (2013)
- Kasahara K, Ishikawa H, Sato S, Shimakawa Y, Watanabe K. Development of multiplex loop-mediated isothermal amplification assays to detect medically important yeasts in dairy products. *FEMS Microbiology Letters*. 357(2): 208-216 (2014)
- Lee JE, Mun H, Kim SR, Kim MG, Chang JY, Shim WB. A colorimetric Loop-mediated isothermal amplification (LAMP) assay based on HRP-mimicking molecular beacon for the rapid detection of *Vibrio parahaemolyticus*. *Biosensors and Bioelectronics*. 151:111968 (2020)
- Liu D, Daubendiek SL, Zillman MA, Ryan K, Kool ET. Rolling Circle DNA Synthesis: Small Circular Oligonucleotides as Efficient Templates for DNA Polymerases. *Journal of the American Chemical Society*. 118(7): 1587-1594 (1996)
- Mackay IM. Real-time PCR in the microbiology laboratory. *Clinical Microbiology & Infection*. 10(3): 190-212 (2004)
- Markoulatos P, Siafakas N, Moncany M. Multiplex polymerase chain reaction: a practical approach. *Journal of Clinical Laboratory Analysis*. 16(1):47-51 (2002)
- Maruyama F, Kenzaka T, Yamaguchi N, Tani K, Nasu M. Detection of bacteria carrying the *stx2* gene by in situ loop-mediated isothermal amplification. *Applied Environmental Microbiology*. 69(8): 5023-5028 (2003)
- Mei X, Zhai X, Lei C, Ye X, Kang Z, Wu X, Xiang R, Wang Y, Wang H. Development and application of a visual loop-mediated isothermal amplification combined with lateral flow dipstick (LAMP-LFD) method for rapid detection of *Salmonella* strains in food samples. *Food Control*. 104: 9-19 (2019)
- Mok M, Marians KJ. Formation of rolling-circle molecules during phi X174 complementary strand DNA replication. *Journal of Biological Chemistry*. 262(5): 2304-2309 (1987)
- Mori Y, Kitao M, Tomita N, Notomi T. Real-time turbidimetry of LAMP reaction for quantifying template DNA. *Journal of Biochemical & Biophysical Methods*. 59(2): 145-157 (2004)
- Nagamine K, Hase T, Notomi T. Accelerated reaction by loop-mediated isothermal amplification using loop primers. *Mol Cell Probes*. 16(3): 223-229 (2002)
- Njiru ZK, Mikosza AS, Armstrong T, Enyaru JC, Ndung'u JM, Thompson AR. Loop-mediated isothermal amplification (LAMP) method for rapid detection of *Trypanosoma brucei* rhodesiense. *Plos Neglected Tropical Diseases*. 2(1): e147 (2008)
- Notomi T, Mori Y, Tomita N, Kanda H. Loop-mediated isothermal amplification (LAMP): principle, features, and future prospects. *Journal of Microbiology*. 53(1): 1-5 (2015)
- Notomi T, Okayama H, Masubuchi H, Yonekawa T, Watanabe K, Amino N, Hase T. Loop-mediated isothermal amplification of DNA. *Nucleic Acids Research*. 28(12): E63 (2000)
- Opet NJ, Levin RE. Efficacy of coating activated carbon with milk proteins to prevent binding of bacterial cells from foods for PCR detection. *Journal of Microbiology Methods*. 94(2): 69-72 (2013)
- Opet NJ, Levin RE. Use of  $\beta$ -cyclodextrin and activated carbon for quantification of *Salmonella enterica* ser. Enteritidis from ground beef by conventional PCR without enrichment. *Food Microbiology*. 38:75-79 (2014)
- Palchetti I, Mascini M. Electroanalytical biosensors and their potential for food pathogen and toxin detection. *Analytical and Bioanalytical Chemistry*. 391(2): 455-471 (2008)
- Panno S, Matić S, Tiberini A, Caruso AG, Bella P, Torta L, Stassi R, Davino S. Loop Mediated Isothermal Amplification: Principles and Applications in Plant Virology. *Plants (Basel)*. 9(4): 461 (2020)
- Pham HM, Nakajima C, Ohashi K, Onuma M. Loop-mediated isothermal amplification for rapid detection of Newcastle disease virus. *Journal of Clinical Microbiology*. 43(4): 1646-1650 (2005)
- Rockett R, Barraclough KA, Isbel NM, Dudley KJ, Nissen MD, Sloots TP, Bialasiewicz S. Specific rolling circle amplification of low-copy human polyomaviruses BKV, HPyV6, HPyV7, TSPyV, and STLPyV. *Journal of Virological Methods*. 215-216: 17-21 (2015)
- Romero MR, D'Agostino M, Arias AP, Robles S, Casado CF, Iturbe LO, Lerma OG, Andreou M, Cook N. An immunomagnetic separation/loop-mediated isothermal amplification method for rapid direct detection of thermotolerant *Campylobacter* spp. during poultry production. *Journal of Applied Microbiology*. 120(2): 469-77 (2016)
- Sano T, Smith CL, Cantor CR. Immuno-PCR: very sensitive antigen detection by means of specific antibody-DNA conjugates. *Science*. 258(5079): 120-122 (1992)
- Settanni L, Corsetti A. The use of multiplex PCR to detect and differentiate food- and beverage-associated microorganisms: a review. *Journal of Microbiological Methods*. 69(1): 1-22 (2007)
- Shen Y, Nie J, Kuang L, Zhang J, Li H. DNA sequencing, genomes and genetic markers of microbes on fruits and vegetables. *Microbial Biotechnology*. 14(2): 323-362 (2021)
- Singh C, Roy-Chowdhuri S. Quantitative Real-Time PCR: Recent Advances. *Methods in Molecular Biology*. 1392: 161-176 (2016)
- Srisawat M, Panbangred W. Efficient and Specific Detection of *Salmonella* in Food Samples Using a stn-Based Loop-Mediated Isothermal Amplification Method. *Biomed Research International*. 2015: 356401 (2015)
- Swaminathan B, Feng P. Rapid detection of food-borne pathogenic bacteria. *Annual Review of Microbiology*. 48: 401-426 (1994)
- Tang MJ, Zhou S, Zhang XY, Pu J-H, Ge Q-L, Tang X-J, Gao Y-S. Rapid and sensitive detection of *Listeria monocytogenes* by loop-mediated isothermal amplification. *Current Microbiology*. 63(6): 511-516 (2011)
- Tao ZY, Zhou HY, Xia H, Xu S, Zhu H-W, Culleton RL, Han E-T, Lu F, Fang Q, Gu Y-P, Liu Y-B, Zhu G-D, Wang W-M, Li J-L, Cao J, Gao Q. Adaptation of a visualized loop-mediated isothermal amplification technique for field detection of *Plasmodium vivax* infection. *Parasites & Vectors*. 4:115 (2011)
- Techathuvanan C, D'Souza DH. Reverse-transcriptase loop-mediated isothermal amplification as a rapid screening/monitoring tool for *Salmonella enterica* detection in liquid whole eggs. *Journal of Food Science*. 77(4): M200-M205 (2012)
- Thompson MG, Burgess JL, Naleway AL, Tyner HL, Yoon SK, Meece J, Olsho LEW, Caban-Martinez AJ, Fowlkes A, Lutrick K, Kuntz JL, Dunnigan K, Odean MJ, Hegmann KT, Stefanski E, Edwards LJ, Schaefer-Solle N, Grant L, Ellingson K, Groom HC, Zunie T, Thiese MS, Ivacic L, Wesley MG, Lamberte JM, Sun X, Smith ME, Phillips AL, Groover KD, Yoo YM, Gerald J, Brown RT, Herring MK, Joseph G, Beitel S, Morrill TC, Mak J, Rivers P, Harris KM, Hunt DR, Arvay ML, Kutty P, Fry AM, Gaglani M. Interim Estimates of Vaccine Effectiveness of BNT162b2 and mRNA-1273 COVID-19 Vaccines in Preventing SARS-CoV-2 Infection Among Health Care Personnel, First Responders, and Other Essential and Frontline Workers - Eight U.S. Locations, December 2020-March 2021. *MMWR-Morbidity and Mortality Weekly Report*. 70(13): 495-500 (2021)
- Tomita N, Mori Y, Kanda H, Notomi T. Loop-mediated isothermal amplification (LAMP) of gene sequences and simple visual detection of products. *Nature Protocols*. 3(5): 877-882 (2008)
- Wang Z, Cai R, Gao Z, Yuan Y, Yue T. Immunomagnetic separation: An effective pretreatment technology for isolation and enrichment

- in food microorganisms detection. *Comprehensive Reviews in Food Science and Food*. 19(6): 3802-3824 (2020)
- Wang ZY, Yang Q, Zhang YZ, Meng Z, Ma X, Zhang W. Saltatory Rolling Circle Amplification (SRCA): a Novel Nucleic Acid Isothermal Amplification Technique Applied for Rapid Detection of *Shigella Spp.* in Vegetable Salad. *Food Analytical Methods*. 11(2): 504-513 (2018)
- Wang, D. Novel primers for increased specificity and sensitivity for the detection of *Staphylococcus aureus* by real-time LAMP. *CyTA - Journal of Food*. 14(1): 88-91 (2016)
- Wu GP, Chen SH, Levin RE. Rapid real-time loop-mediated isothermal amplification combined with coated activated carbon for detection of low numbers of *Salmonella enterica* from lettuce without enrichment. *Food Control*. 56(Complete): 47-52 (2015)
- Xie Z, Peng Y, Luo S, Wang Y, Liu J, Pang Y, Deng X, Xie Z, Xie L, Fan Q, Teng L, Wang X. Development of a reverse transcription loop-mediated isothermal amplification assay for visual detection of avian reovirus. *Avian Pathology*. 41(3): 311-316 (2012)
- Yang Q, Zhang Y, Li S, Lu X, Yuan Y, Zhang W. Saltatory rolling circle amplification for sensitive visual detection of *Staphylococcus aureus* in milk. *Journal of Dairy Science*. 102(11): 9702-9710 (2019)
- Ye L, Li Y, Zhao J, Zhang Z, Meng H, Yan H, Miyoshi S, Shi L. Development of a real-time loop-mediated isothermal amplification assay for the sensitive and rapid detection of *Listeria monocytogenes*. *Letters in Applied Microbiology*. 61(1): 85-90 (2015)
- Yin HY, Fang TJ, Wen HW. Combined multiplex loop-mediated isothermal amplification with lateral flow assay to detect sea and seb genes of enterotoxigenic *Staphylococcus aureus*. *Letters in Applied Microbiology*. 63(1): 16-24 (2016)
- Yu Q, Puthiyakunnon S, Zhang Y, Wu X, Boddu S, Luo B, Fan H. Rapid and Specific Detection of *Escherichia coli* O157:H7 in Ground Beef Using Immunomagnetic Separation Combined with Loop-Mediated Isothermal Amplification. *Polish Journal of Food and Nutrition Sciences*. 68(2): 115-123 (2018)
- Yuan N, Zhang Y, Xu H, Zhou Z, Lu X, Chen T, Yang Q, Tan J, Zhang W. Development of the Saltatory Rolling Circle Amplification Assay for Rapid and Visual Detection of *Alicyclobacillus acidoterrestris* in Apple Juice. *Journal of Agricultural and Food Chemistry*. 68(15): 4538-4545 (2020)
- Zyrina NV, Zheleznyaya LA, Dvoretzky EV, Vasiliev VD, Chernov A, Matvienko NI. N.BspD6I DNA nickase strongly stimulates template-independent synthesis of non-palindromic repetitive DNA by Bst DNA polymerase. *Biological Chemistry*. 388(4): 367-372 (2007)

**Publisher's Note** Springer Nature remains neutral with regard to jurisdictional claims in published maps and institutional affiliations.

Springer Nature or its licensor holds exclusive rights to this article under a publishing agreement with the author(s) or other rightsholder(s); author self-archiving of the accepted manuscript version of this article is solely governed by the terms of such publishing agreement and applicable law.