



Research article

Exergetic sustainability and economic analysis of hybrid solar-biomass dryer integrated with copper tubing as heat exchanger

M.C. Ndukwu^{a,*}, M. Simo-Tagne^b, F.I. Abam^c, O.S. Onwuka^c, S. Prince^a, L. Bennamoun^d^a Department of Agricultural and Bioresources Engineering, Michael Okpara University of Agriculture, Umudike, Nigeria^b LERMaB, ENSTIB, 27 rue Philippe Séguin, PO Box 1041, F-88051 Epinal, France^c Energy, Exergy and Environment Research Group (EERG), Mechanical Engineering Department, Michael Okpara University of Agriculture, Umudike, Nigeria^d Department of Mechanical Engineering, University of New Brunswick, 15 Dineen Drive, E3B 5A3 Fredericton, New Brunswick, Canada

ARTICLE INFO

Keywords:

Energy
 Agricultural engineering
 Environmental analysis
 Environmental assessment
 Environmental engineering
 Environmental impact assessment
 Exergy
 Energy
 Biomass
 Plantain
 Drying
 Hybrid solar dryer

ABSTRACT

The aim of this study is to present a new hybrid solar-biomass dryer and carry out thermal analysis based on energy and exergo-sustainability analysis considering all the available exergy stream of solar radiation, air stream through the collector, and exergy of the moisture in the product. The research also presented the environmental impact and economic analysis of using the dryer. Performance evaluations show that at collector efficiency of 20.81%–21.89 %, the developed solar dryers can save between 10 – 21hrs of drying time in drying 5 mm thick plantain slices to 15 % moisture content from initial moisture content of 66 % w.b when compared to drying under the open sun. The improvement potential ranged from 0.036 to 20.6W while the waste exergy ratios and sustainability index ranged from 0.38 - 0.55 and 2.3–6.11 respectively. Application of the solar dryers can save between 44 -3074 of CO₂ entering the atmosphere per year while 2.94 to 205.43\$ could also be saved at 10–100% rate of usage when compared to diesel fired dryer. The total energy consumption for drying ranges between 5.52 and 35.47 MJ, while the specific energy consumption ranged from 4.3 to 26.2 kWh/kg. The exergy efficiency ranges from 5.6 – 95.13 % during the sunshine hours.

1. Introduction

Most of the African countries are endowed with high solar insolation for most part of the year. Consequently, sun drying became the predominant method of drying of agricultural products. However, in crop processing preservation of organoleptic characteristics, nutritional quality and maintenance of high hygienic level for the dried crop are very important (Ndukwu et al., 2010, 2012). The direct exposure of product to sunlight during sun drying plays a role in the deterioration of the nutritional composition and functional properties of the crops (Madhlopa and Ngwalo, 2007). Additionally, sun drying is highly dependent on the weather conditions and in some cases dried products may contain additional impurities from animal and environmental sources (Boughali et al., 2009; Sharma et al., 2009). Moreover, from the point of view of cost and energy consumption, some studies identified solar drying, as the cheapest among all the other conventional drying methods (Ramde and Forson, 2007; Anyanwu et al., 2012; Simo-Tagne et al., 2019). It provides clean and environmentally friendly energy with flexible design approach based on the need and available resources (Ndukwu et al., 2018; Goud et al.,

2019). However, solar energy when deployed as the only source of heat for drying purpose is not continuously available (Pirasteh et al., 2014; Simo-Tagne and Bennamoun, 2018; Simo-Tagne et al., 2018). Therefore, dried crops can have the problem of rewetting of dried product during the off – sunshine period. Consequently, supplementing solar drying with thermal storage material or an auxiliary heater (hybrid dryers) is proposed as a solution (Pirasteh et al., 2014). However, adding an electrical heater as proposed by Boughali et al. (2009) and Lamrani et al. (2019) may not be a good option for Africa due to very low electricity penetration density. Accordingly, one of the cheapest alternative sources of heat in Africa is the use of biomass waste from farms, agro processing operations and agro-industries. Therefore, using biomass back-up heater becomes more practicable, cheaper and affordable as have been demonstrated by some researchers (Bassey et al., 1987; Bena and Fuller, 2002; Prasad and Vijay, 2005).

Consequently, some research has been conducted in solar biomass drying. Madhlopa and Ngwalo (2007) developed an indirect type natural convection solar dryer integrated with thermal storage and biomass-backup heater for drying pineapple. Okoroigwe et al. (2015)

* Corresponding author.

E-mail address: ndukwumcu@mouau.edu.ng (M.C. Ndukwu).

re-designed a solar dryer with frontal pass solar collector integrated with biomass back-up heater by incorporating a back pass solar collector instead of frontal pass solar collector. Barki et al. (2012) presented performance evaluation of an efficient solar dryer with a backup incinerator for grated Cassava under Makurdi humid climate. Amer et al. (2010) evaluated the performances of a hybrid dryer for drying banana slices. Their proposed design was based on using solar reflectors and a water tank as the heat storage. Ren et al. (2018) studied the feasibility of integrating photovoltaic cells and phase change material (PCM) for the improvement of solar drying. The improvement was shown mainly by the increase of the solar thermal contribution from 82% to 100%. Yassen and Al-Kayiem (2016) developed a solar-biomass hybrid dryer enhanced by the Co-GenTechnique. Dhanushkodi et al. (2014) presented the thermal performance of an active solar-biomass dryer for cashew nut drying.

Generally, the analysis of all the above dryers were limited to drying characteristics by means of recording the temperatures, mass difference of the dried material or drying efficiency and evaluating the drying kinetics. Simultaneous energy, exergy and sustainability analysis based on total exergy stream of solar hybrid dryer with biomass back-up heater are very limited in the literature. Again energy consumption is a very important parameter that enters into account for the selection of drying systems. Apart from being environmentally friendly, combining biomass and solar energy provides low energy density which is an advantage for the crop drying process. Therefore energy and exergy efficiency of the drying systems has often been calculated for proper evaluation of performances (Prommas et al., 2010; Ndukwu et al., 2017). Fudholi et al. (2015) presented performances and improvement potential of solar drying system for palm oil fronds based on exergy and energy analysis. The energy and exergy of solar drying of red weeds was also presented by Fudholi et al. (2014). Hatami et al. (2019) also presented the exergy analysis of solar drying based on new dynamic model. Commonly the general definition of exergy stream in most of the above studies is based on the air stream exergy only (Bennamoun, 2012; Akbulut and Durmus, 2010). However this definition is only useful in steady state drying process (Hatami et al., 2019). According to the authors evaporation that occurs during drying process is not a steady state process and the best definition of exergy in the drying process should be independent of the material amount of the product unlike the current definition. According to Hatami et al. (2019) in drying of materials only exergy exchange with the product is very important in determining the exergy efficiency. Therefore in solar drying the exergy exchange that occurs involves exergy of solar radiation, exergy of air stream through the collector, exergy of

the moisture in the product. This shows the old methods of determining the exergy efficiency as presented by several authors above need to be re-considered. Again, Dincer and Rosen (2013) took the concept of exergy further by stating that it could be a platform for determining the environmental sustainability. Environmental sustainability indicates the efficient supply of energy at lower cost with less damage to the environment (Ndukwu et al., 2017). Understanding sustainability will advance ecological information and policy pronouncements (Dincer and Rosen, 2013). Waste exergy emissions have the potential to upstage the thermodynamic equilibrium of the environment by causing a change when they are emitted. In the case of solar system, this may interfere with atmospheric CO₂ leading to re-radiating of solar radiation by the earth (Dincer and Rosen, 2013).

This study focuses on the analysis of exergy and sustainability (using dynamic method), environmental impact and economic analysis of solar-biomass dryer under the coastal climate of West Africa. The major aim is to develop a low-cost sustainable dryer in a highly humid zone applicable during the harvest period characterized with low average solar insolation. Environmental sustainability factors such as waste exergy ratio, sustainability index, and improvement potential was determined for the developed solar dryer. This method although has been adapted for some energy conversion device but it is scarce in solar-biomass drying analysis with application to West African regions.

2. Material and methods

2.1. Description of the hybrid dryer

The schematic view of the designed solar dryer with biomass furnace is shown in Figure 1. Cost and availability of materials used for the local construction was taken into consideration. This is because the targeted end users are poor local Nigerian farmers. The major challenge is reduction of heat loss through the flue gas from the biomass and also the ease of loading the biomass into the furnace. Piping part of the flue gas and heat behind the inner walls of the drying chamber as heat source before exit is considered instead of direct biomass heating to moderate the drying temperature. Detachable chimney and cover are considered for an easy loading into the biomass furnace.

The designed collector with dimension 1 m × 0.5 m × 0.067m has a transparent glass cover (1 m × 0.5 m × 0.004m), 2 mm thick absorber plate made from aluminum sheet and black painted granite rock pebbles which serves as an absorber also and heat storage material. The solar

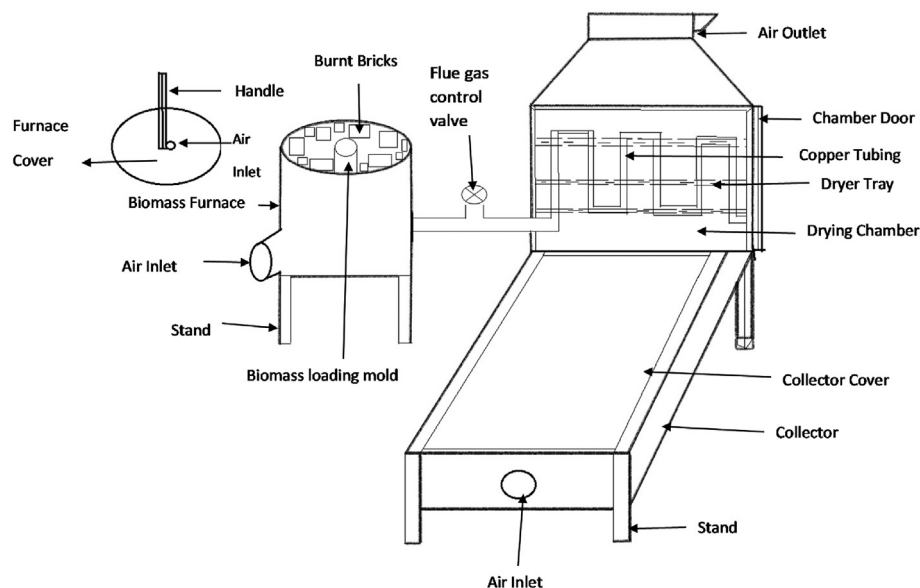

Figure 1. Schematic View of the prototype of the indirect solar dryer with biomass Furnace.

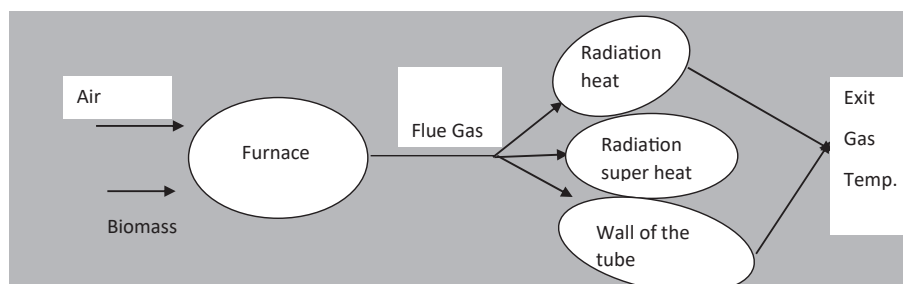

Figure 2. Schematic diagram of furnace heating (adapted from Li et al., 2015).

collector was tilted 15° sloping southwards and perpendicular to the wind direction. The air inlet is at the collector section while the exit is at the drying chamber section. For a solar air heater, Duffie and Beckman (2006) recommended 0.25 m^3 of rock pebbles per m^2 of the collector including void spaces. Accordingly, for the solar collector of 0.5 m^2 presented in this study the volume of granite rock pebbles is 0.125 m^3 . The rock pebbles (123 kg) is laid in a single layer with approximate equivalent diameter of 0.031 m . This gives an average depth of 0.046 m between the glass cover and the rock pebbles. This depth is enough to allow the hot air from the rock pebbles to have enough buoyancy to flow into the drying chamber.

The outer layer of the drying chamber for both dryers is made from plywood while the inner layer is made from the aluminum sheet insulated from the outer layer with latex foam. The drying chambers measure $1 \text{ m} \times 0.5 \text{ m}$. Each dryer contains four trays, with a space of 0.20 m between each tray. The trays are made from wooden frames and wire mesh. For the hybrid solar dryer, the heat and portion of the flue gas from the furnace is piped and coiled behind the inner side walls of the drying chamber with a 10 mm copper tubing before lining the insulator. This enables the heat and the flue gas to flow round the aluminum sheet and exit through an opening. Therefore, heat transfer to the drying chamber from the biomass heater is by conduction through the copper tubing and the inner aluminum wall of the drying chamber. A control valve regulates the heat input from the furnace into the copper tubing. At the back of each dryer, a $1 \text{ m} \times 0.4 \text{ m}$ door is fitted into the drying chamber, for easy loading and unloading of plantain cylinders. The chimney 0.5 m high is an exit channel through which the hot air from the collector escapes to the ambient environment. The chimney is rectangular shaped wooden frame with an opening at one end covered by an overhang to prevent water entering the dryer. The opening is covered with wire mesh to avoid insects entering inside the drying chamber.

The biomass back-up heater is an external heat source. The biomass heater burns wood shaven as the biomass feedstock, for producing supplementary heat energy that can be sent to the drying chamber. The need for a back-up heater is to help reduce drying time and also make drying process continuing during the off-sunshine hours. Clay bricks are carefully lined inside the backup heater furnace, which serves as an insulator. The furnace is constructed with a 3 mm thick double metal sheet. It has a height of 40 cm and diameter of 40 cm . The heat generated from the combustion of the biomass and portion of the flue gas is channeled behind the inner aluminum wall of the drying chamber via a 20 mm diameter steel and 15 mm diameter copper pipe assembly. The aluminum pipe is bent downwards to allow the flow of flue gas into it. Exit temperature of flue gas from the furnace is determined equal to 121°C . A valve is used to regulate the hot air passing through the copper pipe to the drying chamber wall. The biomass heater is used mostly during the night time once the temperature of the drying chamber drops. At that period, it is assumed that the rock pebbles had released all its sensitive stored heat. A total of 2 kg of wood shaven is assumed for the two days drying period with 1 kg for each daily cycle. The wood shaven is densely filled up to 29

cm height and the furnace is intermittently recharged with wood shaven as it burns. This leaves a gap of 11 cm between the cover and the biomass to create space for flue gas buoyancy into the chimney located on the cover. In loading the wood shaven into the combustion chamber, a 6 cm diameter cylindrical duct is carefully created with a pipe where the air-inlet duct into combustion chamber opens. This allows an easy combustion of the biomass and flow of the flue gas.

2.2. Experimental procedure

The experimental analysis was conducted in Umudike, South Eastern Nigeria with geographical location of 5.53°N , 7.49°E during the period of 31^{st} August – 3^{rd} September. This period is characterized with high humidity and low solar radiation intensity most time of the day due to frequent rainfall. Two dryers of the same capacity were assembled with one equipped with biomass furnace (SD_1) while the other was not equipped with biomass furnace (SD_2). Due to the utilization of locally available materials, the cost of assembling the two dryers was estimated at less than $\$200$, though this can vary based on capacity of the dryer. Both dryers were simultaneously operated to ensure the application of the same operating conditions. Solar dryer with biomass furnace operated with biomass back-up heater during off-sunshine hours while solar dryer without biomass heater which serves as the control operated without supplementary heater throughout the drying period. An open sun drying (OSD) experiment was also set up to monitor the effect of the ambient condition. For SD_1 , the hot flue gas was passed through the copper tubing imbedded into the walls of the drying chamber to heat up the drying chamber only. A control valves is used to regulate flue gas passage into the copper tubing. Air temperatures inside the collector and drying chamber are measured with the thermocouple connected to a data logger (HH1147; Omega, Stanford, USA) and a MEXTECH Multi-thermometer. A temperature and humidity clock (DTH-82; TLX, Guangdong China) was used to measure the humidity of the drying chamber and collector at three points in each chamber with the average values used for data analysis. Measurement of wind speed was made with vane anemometer (AM-4826; Landesk, Guangzhou, China), solar radiation intensities was measured with pyranometer (Apogee MP-200, serial 1250, USA). Unripe plantain slices (246 mm in diameter each) weighing 200 g and 0.05 cm thick each is placed on the trays and dried with the solar dryers. The mass of the plantain slices was recorded hourly until it dries to 15% moisture content. The moisture contents of the plantain slices were determined from the weight loss according to Ndukwu et al. (2017). Microsoft excel 2013 software was used for data analysis and plotting of the curves.

2.3. Energy analysis of the hybrid solar dryer

The total energy utilized during the drying period is the total radiation energy received during the sunshine period and the thermal energy

produced by the rock pebbles and biomass during the off-sunshinehours, and this is given by the following equation:

$$T_E = E_R + E_b + E_p \tag{1}$$

E_R is given by Duffie and Beckman (2006) as follows:

$$E_R = A_s F_R [I\tau - U(T_{sc} - T_{ex})] \tag{2}$$

U is given by Ndukwu et al. (2017) as follows:

$$U = U_t + U_b + U_e + U_r \tag{3}$$

$$E_{xa} = \dot{m}_a \left\{ C_{p,a} \left(T - T_0 - T_0 \ln \frac{T}{T_0} \right) + R_a T_0 \times \left[\left(1 + \frac{M_a}{M_v} H \right) \ln \frac{1 + \frac{M_a}{M_v} H_0}{1 + \frac{M_a}{M_v} H} + 1 + \frac{M_a}{M_v} H \ln \frac{H}{H_0} \right] \right\} \tag{11}$$

$$X_w = m_w \left[(h_f(T) - h_f(T_0)) + v_f (P - P_g(T)) - T_0 (S_f(T) - S_g(T_0)) + T_0 R_w \ln \left(\frac{P_g(T_0)}{P_0 X_v^0} \right) \right] \tag{12}$$

The overall heat removal factor, F_R is given by Ndukwu et al. (2017).

$$F_R = \frac{GC_{p,a}}{A_s U_o} \left\{ 1 - e^{-\frac{A_s U_o F_R I}{GC_{p,a}}} \right\} \tag{4}$$

E_p was given by Tiwari (2002) and Madhlopa and Ngwalo (2007) as follows:

$$E_p = m_p c_p (T_p - T_a) \tag{5}$$

The specific heat capacity of the rock pebbles was given as 0.88 kJ/kg.K (Kamble et al., 2013). Additionally assuming all the stream enter and exits the combustion chamber at reference temperature (Costa et al., 2019) the energy consumed by the biomass heater is also given by:

$$E_b = m_b HHV \tag{6}$$

Therefore, the specific energy consumption (kWh/kg) and the specific moisture extraction rate (kg/kWh) are given by Eqs. (7) and (8) respectively (Fudholi et al., 2015):

$$S_{Ec} = \frac{T_E}{w} \tag{7}$$

$$S_M = \frac{W}{T_z} \tag{8}$$

The drying efficiency of the drying process is calculated as follows

$$d_{ef} = \frac{WL}{T_E} \tag{9}$$

2.4. Analysis of the total exergy stream

As stated earlier in the introduction, the general definition of exergy stream in dryer has always been based on the air stream exergy only which is only useful in steady state drying process (Hatami et al., 2019). This is because the evaporation that occurs during drying process is not a steady state process and the definition of exergy in the drying process should be independent of the material amount of the product. Therefore

according to Hatami et al. (2019) in drying of materials exergy exchange with the product is very important in determining the exergy efficiency. Therefore in solar drying the exergy exchange that occurs involves exergy of solar radiation (E_{xR}), exergy of air stream (E_{xa}) through the collector, exergy of the moisture (X_w) in the product given in Eqs. (10), (11), and (12) (Sami et al., 2011; Hatami et al., 2019)

$$E_{xR} = I\tau\alpha_p A_s \left(1 - \frac{T_a}{T_s} \right) \tag{10}$$

T_s is the temperature of the sun given as 4350 K (Bejan et al., 1981; Hatami et al., 2019), M_a is the molecular mass of the air given as 29 g/mol and M_v is the the molecular mass of the vapour given as 18.153 g/mol, P is given as the internal moisture pressure of the product determined as the product of the water activity of the dried material and saturated pressure. letters v, f, 0, g and a, are subscripts indicating the thermodynamic states, R is the universal gas constant given as 0.446 kJ kg⁻¹ K⁻¹ for vapour and 0.278 kJ kg⁻¹ K⁻¹ for air, X_v^0 is the molar ratio of water vapour in the air taken as 0.004.

The biomass heater was added to continue the drying process during off sunshine period. The major limitation of the system is the maximization of the heat transfer within the system. Therefore the exergy input of the heater will depend on the available energy within the system. Therefore In the analysis of the exergy contribution of the biomass heater to the drying system, the exergy exchange that occurs is the exergy of burning the biomass (E_{xb}) which produces the flue gas and increase the gas hot stream that passes through the copper pipes to heat up the walls of the drying chamber as shown in Figure 2 (Li et al., 2015).

Assuming that (1) air flowing in to be at ambient condition (2) the furnace operates at steady state condition (3) the air carrying the flue gas and the flue gas is in ideal state (4) potential and kinetic exergy is ignored (Li et al., 2015), (5) the biomass is completely dried so that evolution of moisture is ignored. Therefore Eq. (17) was applied to the control volume for exergy balance of the biomass in the combustion chamber (Li et al., 2015; Costa et al., 2019)

$$T_0 \dot{S}_{gen} = \sum \left(1 - \frac{T_0}{T} \right) \dot{Q}_{cv} - \dot{W}_{cv} + \sum \dot{m}_i (e_{si} e_{chi}) - \sum \dot{m}_o (e_{so} e_{cho}) \tag{13}$$

The exergy stream for the biomass is given as follows (Li et al., 2015; Costa et al., 2019)

$$\dot{E}_{xb} = \dot{m}(e_s e_{ch}) \tag{14}$$

The specific exergy (e_s) is given as follows

$$e_s = (h - h_0) - T_0(S - S_0) = C_p \left[(T - T_0) - T_0 \ln \frac{T}{T_0} \right] \tag{15}$$

Due to the complex nature of determining the specific chemical exergy (e_{ch}) of the biomass fuel, a correlation has been presented based

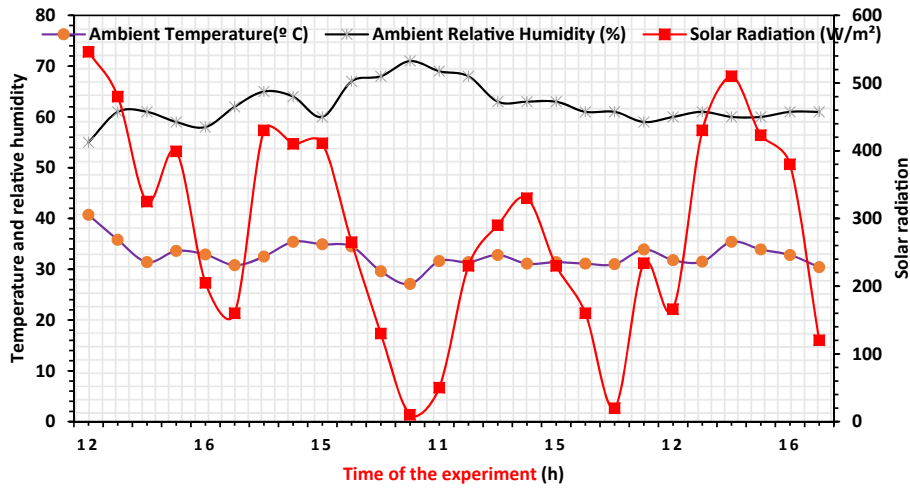

Figure 3. Ambient Temperature, Relative Humidity and Solar Radiation intensity profile.

on the high heating values (HHV) of the biomass (Song et al., 2011; Li et al., 2015) as follows

$$e_{chf} = 1.047 \times HHV \tag{16}$$

The HHV for dried wood shaven is given as 1.76×10^7 J/kg (Madhlopa and Ngwalo, 2007).

For the specific chemical exergy of the flue gas taken as ideal gas is given as (Costa et al., 2019)

$$e_{chg} = RT_0 \frac{y_i}{y_o} \tag{17}$$

Therefore for overall system analysis which includes the biomass heater, the collector, drying chamber and the product for SD₁ but excludes biomass heater only for SD₂ is given in Eqs. (22), (23), and (24). The input exergy (E_{xi}) for SD₁ is given in Eq. (18) while Eq. (19) gives that of the SD₂. The output exergy is given in Eq. (20) for SD₁ and SD₂.

$$E_{xi} = E_{x_{bi}} + E_{x_R} + E_{x_{ai}} + X_{wi} \tag{18}$$

$$E_{xi} = E_{x_R} + E_{x_{ai}} + X_{wi} \tag{19}$$

For output exergy, Eq. (20) gave the output exergy for SD₁ while Eq. (21) gives the output exergy for SD₂

$$E_{xo} = X_{wo} + E_{x_{ao}} + E_{x_{bo}} \tag{20}$$

$$E_{xo} = X_{wo} + E_{x_{ao}} \tag{21}$$

Therefore the exergy efficiency is represented by Eq. (22) as follows

$$E_{x_{ef}} = 1 - \frac{E_{xi} - E_{xo}}{E_{xi}} \tag{22}$$

2.5. Environmental sustainability indicators

Dincer and Rosen (2013) suggested that exergy concept is the best to address the environmental impact mitigation of energy resources utilization to increase energy utilization efficiency. As a result, Dincer (2011) presented some sustainability indicators in his analysis of renewable energy approach for sustainable growth which includes waste exergy ratio (WER) and sustainability index (SI). While, Fudholi et al. (2014) added the improvement potential (IP) in exergy process analysis. These indicators are shown in Eqs. (23), (24), and (25).

$$WER = \frac{E_{xi} - E_{xo}}{E_{xin}} \tag{23}$$

$$SI = \frac{1}{1 - E_{x_{ef}}} \tag{24}$$

The improvement potential (I) of the system is calculated as follows (2014):

$$I = (1 - E_{x_{ef}})(E_{xi} - E_{xo}) \tag{25}$$

2.6. Environmental impact

The energy utilization of the solar dryer is compared with a diesel powered artificial dryer. Ould-Amrouche et al. (2010) presented the energy produced by a diesel generator in kWh as follows

$$D_E = v_f k_f \eta_f \tag{26}$$

If equal amount of diesel is to be burnt to produce the same thermal energy to dry the plantain slice, therefore the volume of diesel burnt can be deduced by combining Eqs. (5) and (30) as follows

$$E_R + E_b + E_p = v_f k_f \eta_f \tag{27}$$

The volume of diesel that will produce equal thermal energy for drying the plantain slice is given by:

$$v_f = \frac{E_R + E_b + E_p}{k_f \eta_f} \tag{28}$$

Ndukwu et al. (2017) gave the amount (kg) of CO₂ produced for a given liter of fuel as follows:

$$m_c = v_f k_d \tag{29}$$

The values of η_f , k_d , and k_f are determined from Ould-Amrouche et al. (2010) as 30%, 2.63 kg/l and 10.08 kWh/l respectively.

Therefore the amount of CO₂ reduced in terms of rate of operation of the solar drying usage is given as Elhage et al. (2018).

$$M_{CO_2 \text{ reduced}} = M_c \cdot P \tag{30}$$

Where P is the percentage of the period, the dryer is operational in a year which ranges between 0.1 to 1.0 Elhage et al. (2018).

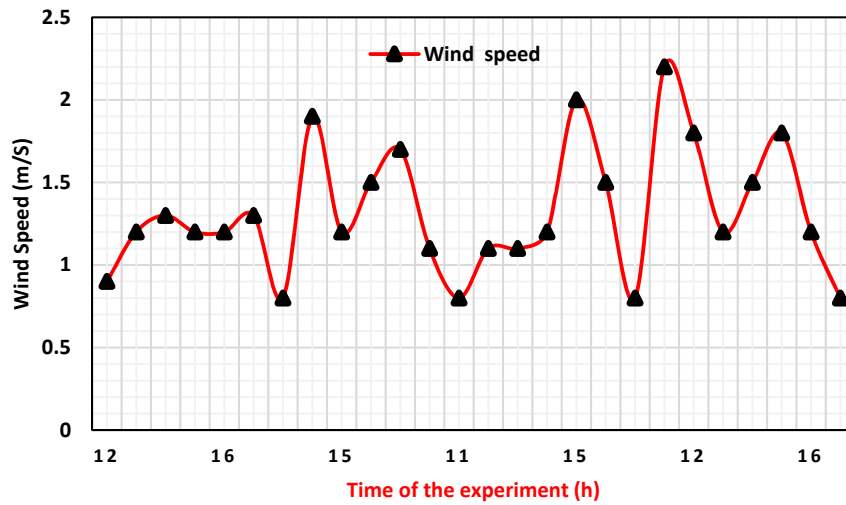

Figure 4. Ambient wind speed profile versus time of the experiment.

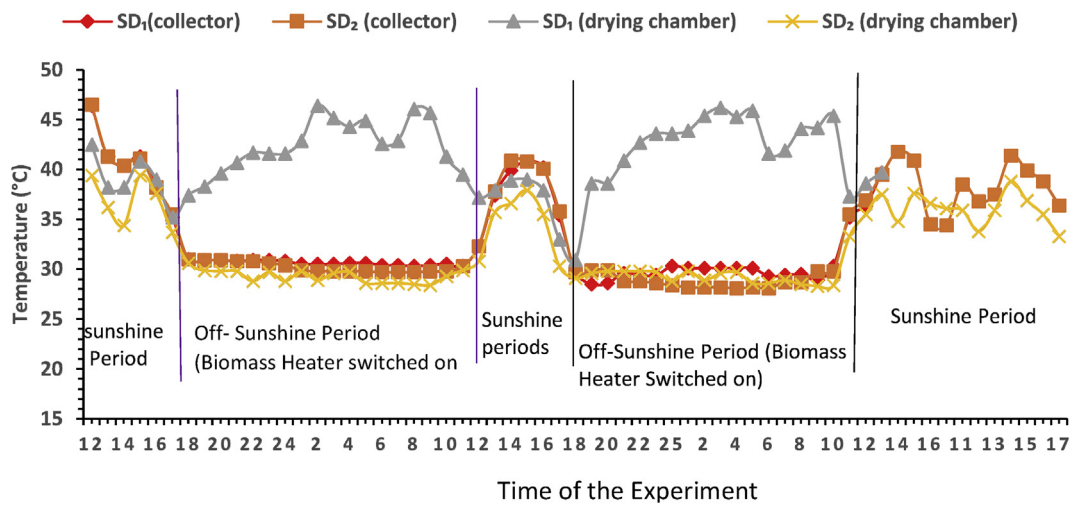

Figure 5. Collector and drying chamber temperature profile versus time of the experiment.

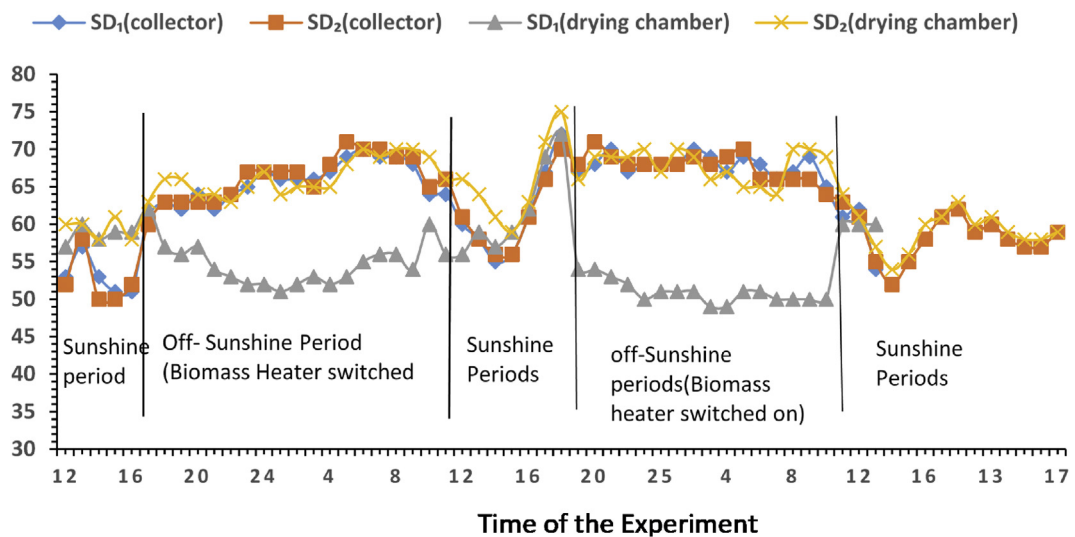

Figure 6. Collector and drying chamber humidity profile versus time of the experiment.

Table 1. Performance parameters for solar dryer and hybrid dryer with biomass heater.

Parameters	Units	SD ₁	SD ₂	OSD
Total Energy gained by collector	MJ	3.321	5.618	-
Total Energy loss by collector	MJ	0.0549	0.0995	-
Total Thermal energy consume by biomass heater	MJ	35.2	-	-
Total useful energy consumed	MJ	38.47	5.519	-
Collector efficiency	%	21.89	20.81	-
Total Mass of water removed	kg	0.4076	0.36772	0.351
Drying efficiency		8.4	14.64	
Specific energy consumption	kWh/kg	26.2	4.29	-
Specific moisture extraction rate	kg/kWh		0.233324	-
Specific heat capacity of the flue gas	kJ/kg.K	0.9948	-	-
Average overall humidity of collector (night and day)	%	69.06	67.08	-
Average overall exit humidity of drying chamber (night and day)	%	55.3	64.44	-
Total sunshine hours	hr	15	26	34
Average wind speed	m/s	1.336	1.336	-
Initial moisture content	(%wb)	50.75	50.75	50.75
Final moisture content	(%wb)	15	15	17.1
Initial mass	kg	0.8	0.8	0.8
Final mass	kg	0.392	0.394	0.408
Average solar radiation	W/m ²	289.4	282.5	285.6

2.7. Economic analysis of the solar dryers

The energy utilized by solar dryers can be determined as a product of power consumed and total time taken for drying purpose (Elhage et al., 2018) as follows

$$Q_c = p.t \tag{31}$$

Where p is the power utilized and t is the total drying time for each day given by Elhage et al. (2018) as follows.

$$t = \frac{M}{C} T \tag{32}$$

Assuming 20 days of operational period per month (Elhage et al., 2018) and 12 months per year, the total energy consumed per year will be given as

$$Q_{year} = Q_c.op.12 \tag{33}$$

Where op is the number of operational period (day) per month. Therefore the total amount of money that could be saved per year is calculated as

$$N_{yr} = p_u.Q_{year}.P_E \tag{34}$$

P_E is the price of one kWh of energy in Nigeria given as 0.08\$ (Global electricity price, 2018) and p_u is the percentage usage given as 0.1 to 1 (Elhage et al., 2018).

3. Results and discussion

3.1. Solar dryer performances

The location of the evaluation of the solar dryer is Lat.05°29', Long.07°33', Alt.122m and the period is characterized with high humidity and low solar insolation most of the time as shown in Figure 3, which shows that the maximum radiation reached is around 550 W/m² Figure 3 shows also that the ambient temperature changed between 30 to 40 °C and a humidity from 55 to 70%. Solar drying starts on the appearance of clear sky for SD₂ and SD₁ and stops at the end of the sunshine period. However, SD₁ continues drying till biomass heater fuel burns off. Before the appearance of clear sky, the received radiation is used to warm-up the solar collector as the temperature difference is not enough to cause any weight loss on the plantain slice. This observation is

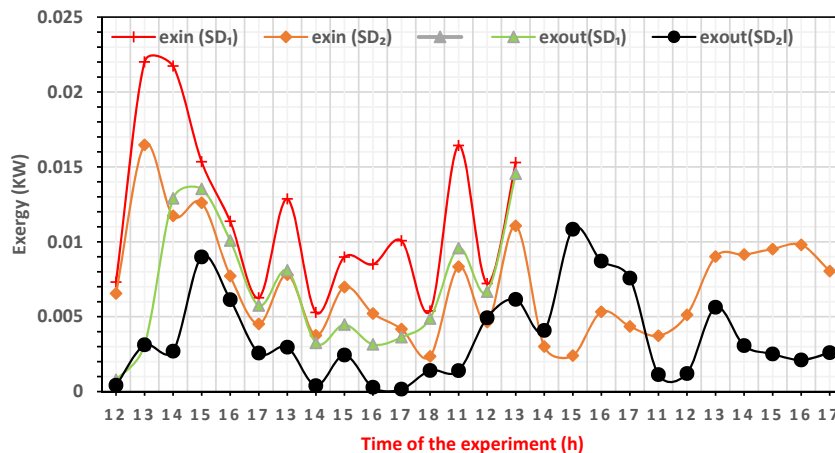

Figure 7. Variations in inlet (exin) and outlet (exout) exergy of the solar dryers versus time of the experiment.

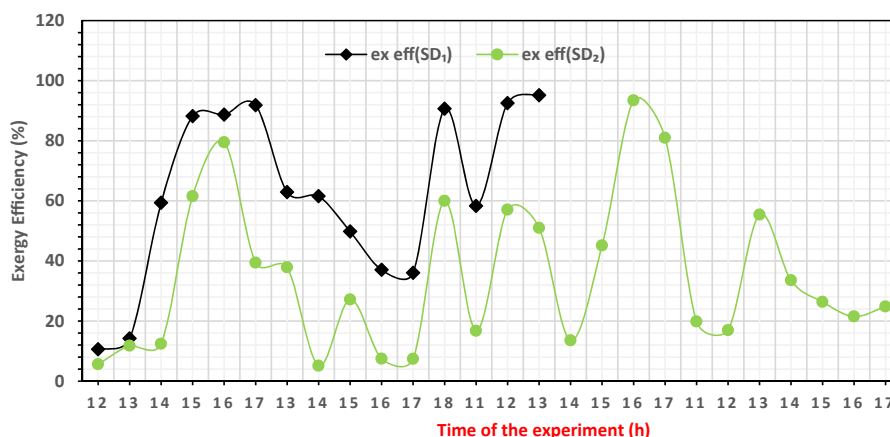

Figure 8. Changes in the exergy efficiency of the solar dryers versus time of the experiment.

in agreement with the study presented by Bennamoun and Belhamri (2003) and Ndukwu et al. (2018). They found in their study that radiation received between 5am and 8 am is used to warm-up the collector and during this lap of time the decrease of the moisture content is very low. The variation of the ambient air speed during the sunshine hours is shown in Figure 4 and ranged between 0.8 and 2 m/s. It is noticed that increased ambient air speed decreases the collector temperature and by extension the drying time. This remark is also in agreement with the results presented by Bennamoun and Belhamri (2006), where they found that increasing the air velocity entering the solar collector causes a decrease in its exit temperature. Moreover, Figure 4 shows that the shape of the exit collector temperature is similar to the solar radiation. Consequently, the collector temperature increases with the solar radiation increase and decreases with the solar radiation decrease. However, Bennamoun and Belhamri (2006), found that there is a reaction time for the solar collector. Accordingly, the highest temperature reached at the collector is reached of about one hour after the highest solar radiation. This reaction time or inertia increases with the total surface of the solar collector. This reaction time is not observed in this study and this is probably due to the small surface used in our study. As expected, the solar insolation and temperature of the solar collector increases towards the noon while the humidity decreases as shown in Figures 3, 5, and 6. The exit temperature and humidity of the drying chamber follows also the

same variation of the solar radiation and the air ambient conditions. These results validate the strong effect of solar radiation during the drying in sunshine hours. However, Figures 5 and 6 show that the changes between the inlet and exit temperature and humidity continue at night for SD₁ due to support from the biomass heater. This drove the drying process at night for SD₁ and shortens the drying time as shown in the Figures. The biomass heater is used mostly in the night time from about 6-7 p.m. local time. During this period, it is assumed that the rock pebbles have released all its sensible heat stored as indicated by the continuous collector temperature drop and solar insolation approaching zero. During the sunshine period, the solar insolation, ambient temperature and humidity peaks at 546 W/m², 40.7 °C and 71% respectively while the lowest value are 10W/m², 27.1 °C and 55%. This indicates the daily solar radiation intensity is relatively low in this region and the importance of adding a supplementary source of heating. Maximum temperature difference of 13.7 °C is obtained for the collector and the ambient despite the low radiation. However, it is noteworthy that the collector temperature for SD₁ is marginally higher than that of SD₂ during the night time and shows no condensation in the morning unlike SD₂ in the first day. The entrance to the solar collector is blocked in the evening from the second day to prevent rewetting in SD₂. Generally, the exit temperature of the SD₁ is higher than the collector temperature in the night and peaks at 46.1 °C with a maximum difference of 15.7 °C with

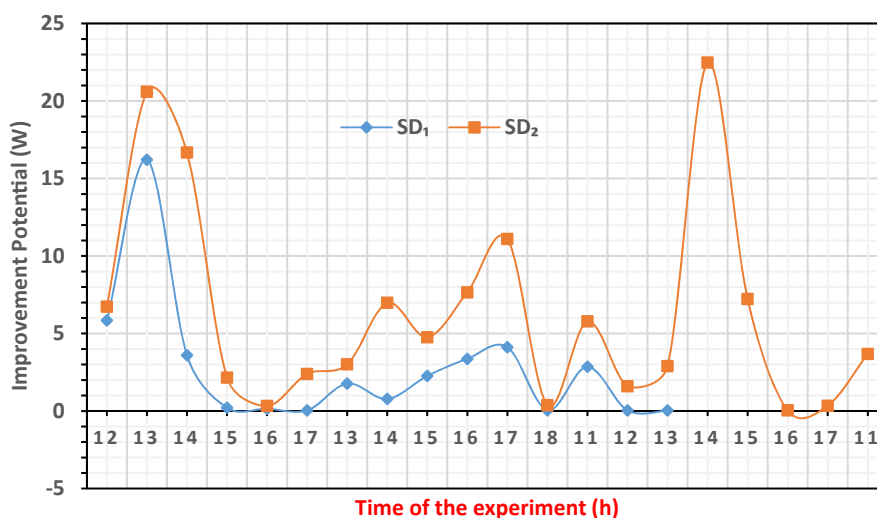

Figure 9. Variation of the improvement potential for the two treatments with time of the experiment.

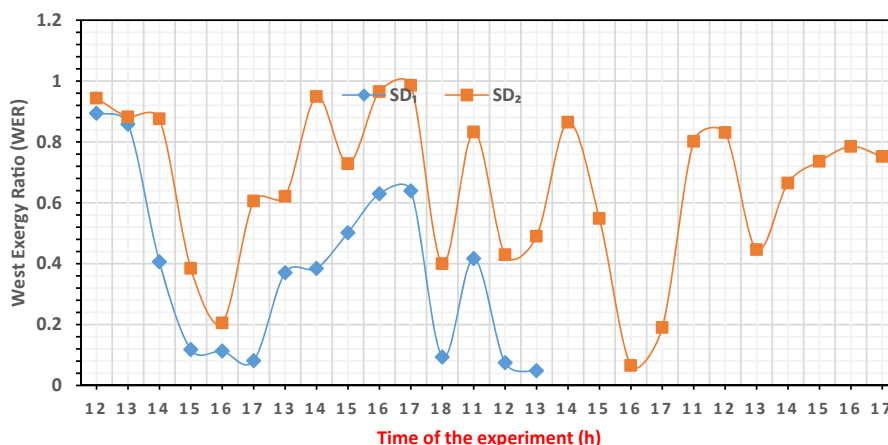

Figure 10. Waste exergy ratio profile with time of the experiment.

the ambient temperature. In other to maintain uniformity of drying, the trays are intermittently switched as suggested by some researchers (Bennamoun and Li, 2018; Stiling et al., 2012). Table 1 shows the summary of the observations and average values of the experimental results of the two systems and open sun drying. The average collector efficiency is about 22 and 21% for SD₁ and SD₂ while the drying efficiency were 8.4 and 14.64 % respectively. This value is within the range reported by Fudholi et al. (2014). The evolution of temperature using the biomass heater helped to maintain a lower average exit humidity of 55.3 % in the drying chamber SD₁ compared to 64.4 % for SD₂ as shown in Table 1.

3.2. Energy utilization

Table 1 also shows the total energy consumption for SD₁ and SD₂. The solar biomass dryer uses about 38.4MJ of thermal energy to reduce the moisture content of the sliced plantain from 50.75 % to 15% w.b in 2 days while SD₂ utilized 5.52MJ of thermal energy to perform the same task in 4 days. However, the specific moisture extraction rate is 0.038 kg/kWh for SD₁ and 0.233 kg/kWh for SD₂ while the specific energy consumption which is a measure of the effectiveness of energy utilization is calculated as 26.2 kWh/kg and 4.4 kWh/kg for SD₁ and SD₂ respectively. Theoretically based on energy utilization SD₂ looks more effective but

when other cost implication in terms of length of drying is considered SD₁ might be more effective.

3.3. Exergy performance of the solar dryers

The variation of the exergy stream at different time of the day for the two dryers is shown in Figure 7. Exergy presents a tool for rationally comparing processes and systems (Dincer and Rosen, 2013). It is useful in ascertaining the causes, locations, and scales of process and system inefficiencies. Exergy analysis recognizes the degradability of energy quality to a state of uselessness although energy can neither created nor destroyed as stated by first law of thermodynamics (Dincer and Rosen, 2013). Exergy is the minimum work needed by the system combination of the control mass and the ambient in bringing the control mass to the final state from the dead state. The results show that exergy of the solar dryers is strongly affected by the weather variations with a maximum inlet value of 0.022kW for SD₁ and 0.024 kW for SD₂ while the maximum exit values were 0.0145 kW and 0.0108 kW for SD₁ and SD₂ respectively. The exergy loss which is a true loss of potential is used in the calculation of the exergy efficiency shown in Figure 8. The exergy efficiency ranges from 10.6 – 95.13 % for SD₁ and 5.6–93 % for SD₂. The system with highest losses presents lowest efficiency and provides a clue where effort

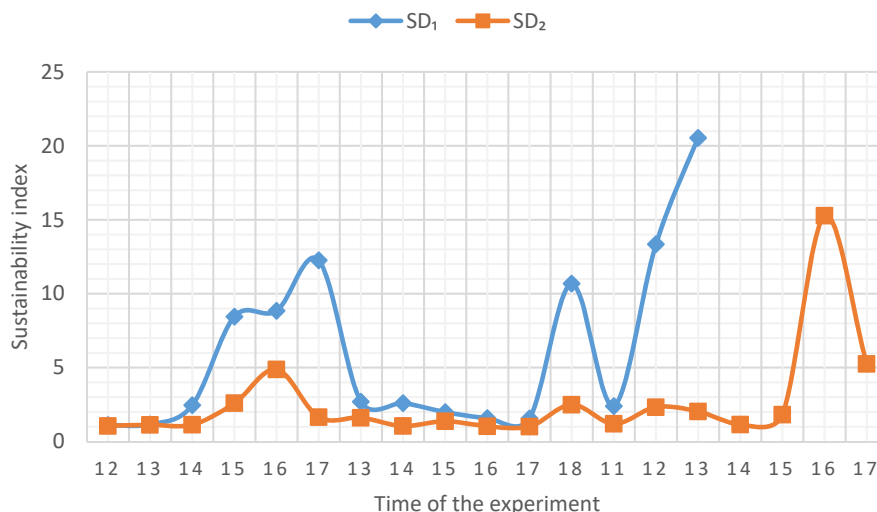

Figure 11. Sustainability index versus Time of the experiment.

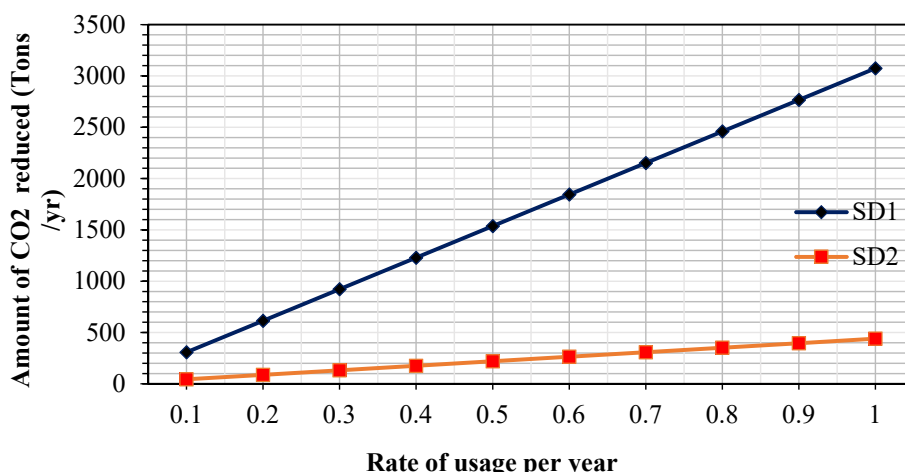

Figure 12. Possible amount of CO₂ to be mitigated per year from entering the atmosphere using the solar.

should be focused for improvement. This shows that SD₁ requires more attention especially in harnessing the energy generated by the biomass heater. It is noted that minimizing exergy losses increases the energy efficiency of a process. Therefore, an exergetic improvement potential on a rate base is introduced in exergy analysis. For the sunshine hours the improvement potential, shown in Figure 9, ranges from 0.036–16.2 W for SD₁ and 0.04–20.6 W for SD₂.

3.4. Sustainability indices

Exergy analysis covers the interdisciplinary triangle of energy, environment and sustainability. The extent of exergy loss to the environment has sustainability implications. It can lengthen or lower the live of available resources, thereby affecting how material, labour and devices are utilized (Dincer and Rosen, 2013). Increased air temperature in solar collector and lower vapour pressure and humidity creates the moisture gradient that transports the moisture from the crops into the environment during drying (Ndukwu et al., 2017). Exergy loss to the environment during drying occurs through the moisture expulsion process. Waste exergy ratio expresses the magnitude of this loss in terms of input exergy as shown in Figure 10 for sunshine periods. It

ranges from 0.05 – 0.89 with average value of 0.38 for SD₁ and 0.07–0.94 with average value of 0.55 for SD₂ while it is determined as 0.96 for the biomass heater. The sustainability index which is a measure of the components producing the exergy versus time of the experiment is shown in Figure 11. The average values are between 6.11 and 2.3 for SD₁ and SD₂ respectively while it is 1.05 for the biomass heater.

3.5. Environmental impact

Global warming refers to increase in normal temperature of the earth as a result of increased greenhouse gases emissions that traps the heat radiated from the earth surface, raising its temperature. The major advantage of solar dryers is the potential of limiting the emission of greenhouse gases like carbon dioxide. A comparison is made in terms of relying on saved fuel from diesel fired generator that would have been used to produce equivalent energy consumed by the dryers. Based on the rate of usage ranging from 10–100 % usage, the amount of CO₂ reduced from entering the atmosphere is shown in Figure 12. This study shows that it increased from 307.4 to 3074 tons of CO₂ for SD₁ and 44–440 tons of for SD₂ respectively.

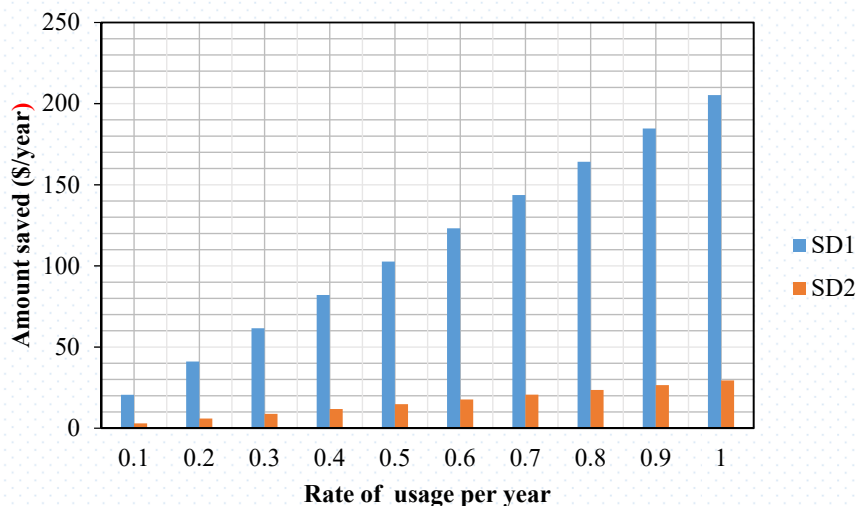

Figure 13. Possible amount of money saved per year in using solar dryer.

3.6. Economic and money saving potentials of solar dryers

To analyze the amount of money that can be saved in solar drying of crops using the solar dryers, the rate of operation was grade from 10 to 100 % of operation (Elhage et al., 2018). This is because in Nigeria for example, the average sunshine hours vary from 3.5 in the south to 9 h towards the north. Therefore the percentage of usage will also vary due to number of hours of sunshine available per day. Figure 13 shows that the amount of money saved increased from 20.5- 205.17\$/year for SD₁ while it increased from 2.94 – 29.443/year for SD₂. In a region that lives below an income of 1\$ per day, this is a lot of money and when the environmental aspect is incorporated it will make a huge difference on the life of the farmers.

4. Conclusion

The following conclusion can be drawn from this research. In a coastal environment of West Africa characterized by high humidity and low sunshine hours, the utilized solar dryers can save between 10 – 21hrs of drying time in drying 5 mm thick plantain slices to 15 % moisture content from initial moisture content of 66 % w.b when compared to drying under the open sun. There was almost no difference in the average collector temperatures of SD₁ and SD₂ leading to a collector (thermal) efficiency of about 21.89 % for SD₁ and 20.81% for SD₂. The total energy consumption for drying ranges from 5.52 – 35.47 MJ, while the specific energy consumption is 26.2 and 4.3 kWh/kg for SD₁ and SD₂ respectively. The exergy of the solar dryers is strongly affected by the weather variations with a peak inlet value of 0.022kW for SD₁ and 0.024 kW for SD₂ while the peak exit values are 0.0145 kW and 0.0108 kW for SD₁ and SD₂ respectively during the sunshine hours of drying. The exergy efficiency ranges from 10.6 – 95.13 % for SD₁ and 5.6–93 % for SD₂ during the sunshine hours; however the overall exergy efficiency of the biomass heater is <5 % which reduces the overall efficiency of SD₁ to <3.1 %. This shows that SD₁ requires more attention especially in harnessing the energy generated by the biomass heater. The improvement potential ranges from 0.036 –16.2 W for SD₁ and 0.04–20.6 W for SD₂ while the waste exergy ratio exists from 0.05 – 0.89 with average value of 0.38 for SD₁ and 0.07–0.94 with average value of 0.55 for SD₂ while it is determined as 0.96 for the biomass heater. The sustainability index values exist at 6.11 and 2.3 for SD₁ and SD₂ respectively while it is 1.05 for the biomass heater. Application of the solar dryers can save between 44 –3074 of CO₂ entering the atmosphere per year while 2.94 to 205.43\$ could also be saved at 10–100% rate of usage.

Declarations

Author contribution statement

M.C. Ndukwu: Conceived and designed the experiments; Performed the experiments; Analyzed and interpreted the data; Wrote the paper.

M. Simo-Tagne, F.I. Abam, O.S. Onwuka & L. Bennamoun: Analyzed and interpreted the data; Wrote the paper.

S. Prince: Performed the experiments.

Funding statement

This research did not receive any specific grant from funding agencies in the public, commercial, or not-for-profit sectors.

Competing interest statement

The authors declare no conflict of interest.

Additional information

No additional information is available for this paper.

References

- Akbulut, A., Durmus, A., 2010. Energy and exergy analyses of thin layer drying of mulberry in a forced solar dryer. *Energy* 35, 1754–1763.
- Amer, B.M.A., Hossain, M.A., Gottschalk, K., 2010. Design and performance evaluation of a new hybrid solar dryer for banana. *Energy Convers. Manag.* 51, 813–820.
- Anyanwu, C.N., Oparaku, O.U., Onyegegbu, S.O., Egwuatu, U., Edem, N.I., Egbuka, K., Nwosu, P.N., Sharma, V.K., 2012. Experimental investigation of a photovoltaic-powered solar Cassava dryer. *Dry. Technol.* 30, 398–403.
- Barki, E., Ibrahim, J.S., Eloka-Eboka, A.C., 2012. Performance evaluation of an efficient solar dryer with a backup incinerator for grated Cassava under Makurdi humid climate. *Int. J. Environ. Bioenergy* 1, 131–139.
- Bassey, M.W., Whitfield, M.J., Korama, E.Y., 1987. Problems and solutions for natural convection solar crop drying. In: Bassey, M.W., Schmidt, O.G. (Eds.), *Solar Crop Drying in Africa. Proceedings of Food Drying Workshop, Dakar, IDRC, Ottawa, Canada.*
- Bejan, A., Kearney, D., Kreith, F., 1981. Second Law Analysis and Synthesis of Solar Collector Systems. *ASME Trans. J. Solar Energy Eng.* 103, 23–28.
- Bena, B., Fuller, R.J., 2002. Natural convection solar dryer with biomass backup heater. *Sol. Energy* 72, 75–83.
- Bennamoun, L., Belhamri, A., 2003. Design and simulation of a solar dryer for agriculture products. *J. Food Eng.* 59, 259–266.
- Bennamoun, L., Belhamri, A., 2006. Numerical simulation of drying under variable external conditions: application to solar drying of seedless grapes. *J. Food Eng.* 76, 179–187.
- Bennamoun, L., 2012. An overview on application of exergy and energy for determination of solar drying efficiency. *Int. J. Energy Eng.* 2, 184–194.
- Bennamoun, L., Li, J., 2018. Drying process of food: fundamental aspects and mathematical modeling. In: Grumezescu, A.M., Holban, A.M. (Eds.), *Natural and Artificial Flavoring Agents and Dyes*, 7. Handbook of Food Engineering, pp. 29–82.
- Boughali, S., Benmoussa, H., Bouchekima, B., Mennouche, D., Bouguettaia, H., Bechki, D., 2009. Crop drying by indirect active hybrid solar – electrical dryer in the eastern Algerian Septentrional Sahara. *Sol. Energy* 83, 2223–2232.
- Costa, V.A.F., Tarelho, L.A.C., Sobrinho, A., 2019. Mass, energy and exergy analysis of a biomass boiler: a Portuguese representative case of the pulp and paper industry. *Appl. Therm. Eng.*
- Dincer, I., 2011. Exergy as a potential tool for sustainable drying systems. *Sustain. Cities Soc.* 1, 91–96.
- Dincer, I., Rosen, M.A., 2013. *Exergy Energy, Environment and Sustainable Development.* Elsevier Ltd. The Boulevard, Langford Lane, Kidlington, Oxford OX5 1GB, UK.
- Dhanushkodi, S., Wilson, V.H., Sudhakar, K., 2014. Thermal performance evaluation of indirect forced cabinet solar dryer for cashew drying. *Am.-Eurasian J. Agric. Environ. Sci.* 14, 1248–1254.
- Duffie, J.A., Beckman, W.A., 2006. *Solar Engineering of Thermal Process.* Wiley, New York.
- Elhage, H., Herez, A., Ramadan, M., Bazzi, H., Khaled, M., 2018. An investigation on solar drying: a review with economic and environmental assessment. *Energy.*
- Fudholi, A., Sopian, K., Othman, M.Y., Ruslan, M.H., 2014. Energy and exergy analyses of solar drying system for red seaweed. *Energy Build.* 68, 121–129.
- Fudholi, A., Sopian, K., Alghoul, M.A., Hafidz, M., Yusof Othman, R.M., 2015. Performances and improvement potential of solar drying system for palm oil fronds. *Renew. Energy* 78, 561–565.
- Global electricity price, 2018. [Globalpetrolprices.com. Egypt Electricity prices. http://www.globalpetrolprices.com/Egypt/Electricity_prices/](http://www.globalpetrolprices.com/Egypt/Electricity_prices/). Downloaded 16th March 2019.
- Goud, M., Vardhan Reddy, M.V., Chandramohan, V.P., Suresh, S., 2019. A novel indirect solar dryer with inlet fans powered by solar PV panels: drying kinetics of Capsicum Annum and *Abelmoschus esculentus* with dryer performance. *Sol. Energy* 194, 871–885.
- Hatami, S., Payehaneh, G., Mehrpanahi, A., 2019. Energy and exergy analysis of an indirect solar dryer based on a dynamic model. *J. Clean. Prod.*
- Kamble, A.K., Pardeshi, I.L., Singh, P.L., Ade, G.S., 2013. Drying of chilli using solar cabinet dryer coupled with gravel bed heat storage system. *J. Food Res. Technol.* 1, 87–94.
- Lamrani, B., Khouya, A., Draoui, A., 2019. Energy and environmental analysis of an indirect hybrid solar dryer of wood using TRNSYS software. *Sol. Energy* 183, 132–145.
- Li, C., Gillum, C., Toupin, K., Donaldson, B., 2015. Biomass boiler energy conversion system analysis with the aid of exergy-based methods. *Energy Convers. Manag.* 103, 665–673.
- Madhlopa, A., Ngwalo, G., 2007. Solar dryer with thermal storage and biomass-backup heater. *Sol. Energy* 81, 449–462.
- Ndukwu, M.C., Ogunlowo, A.S., Olukunle, O.J., 2010. Cocoa Bean (*Theobroma cacao* L.) drying kinetics. *Chil. J. Appl. Agri.* 70, 633–639.
- Ndukwu, M.C., Simonyan, K.J., Ndirika, V.I.O., 2012. Investigation of the structural changes of cocoa bean (with and without seed coat) during convective drying. *Int. J. Agric. Biol. Eng.* 5 (3), 75–82.
- Ndukwu, M.C., Abam, F.I., Manuwa, S.I., Briggs, T.A., 2017a. Exergetic performance indicators of a direct evaporative cooling system with different evaporative-cooling pads. *Int. J. Ambient Energy* 38, 701–709.
- Ndukwu, M.C., Bennamoun, L., Abam, F.I., Eke, A.B., Ukoha, D., 2017b. Energy and exergy analysis of a solar dryer integrated with sodium sulfate decahydrate and sodium chloride as thermal storage medium. *Renew. Energy* 113, 1182–1192.
- Ndukwu, M.C., Bennamoun, L., Abam, F.I., 2018. Experience of solar drying in Africa: presentation of designs, operations and models. *Food Eng. Rev.* 10, 211–244.

- Okoroigwe, E.C., Ndu, E.C., Okoroigwe, F.C., 2015. Comparative evaluation of the performance of an improved solar-biomass hybrid dryer. *J. Energy South Afr.* 26, 38–50.
- Ould-Amrouche, O., Rekioua, D., Hamidat, A., 2010. Modelling photovoltaic water pumping systems and evaluation of their CO₂ emissions mitigation potential. *Appl. Energy* 87, 3451–3459.
- Pirasteh, G., Saidur, R., Rahman, S.M.A., Rahim, N.A., 2014. A review on development of solar drying applications. *Renew. Sustain. Energy Rev.* 31, 133–148.
- Prasad, J., Vijay, V.K., 2005. Experimental studies on drying of *Zingiber officinale*, *Curcuma l.* and *Tinospora cordifolia* in solar-biomass hybrid drier. *Renew. Energy* 30, 2097–2109.
- Prommas, R., Rattanadecho, P., Cholaseuk, D., 2010. Energy and exergy analyses in drying process of porous media using hot air. *Int. Commun. Heat Mass Tran.* 37, 372–378.
- Ramde, E.W., Forson, F.K., 2007. Computer aided-sizing of direct mode natural convection solar crop dryers. *J. Eng. Technol.* 1, 1–9.
- Ren, H., Ma, Z., Lin, W., Fan, W., Li, W., 2018. Integrating photovoltaic thermal collectors and thermal energy storage systems using phase change materials with rotary desiccant cooling systems. *Sustain. Cities Soc.* 36, 131–143.
- Sami, S., Etesami, N., Rahimi, A., 2011. Energy and exergy analysis of an indirect solar cabinet dryer based on mathematical modeling results. *Energy* 36, 2847–2855.
- Sharma, A., Chen, C.R., Vu Lan, N., 2009. Solar-energy drying systems: a review. *Renew. Sustain. Energy Rev.* 13, 1185–1210.
- Simo-Tagne, M., Bennamoun, L., 2018. Numerical study of timber solar drying with application to different geographical and climatic conditions in Central Africa. *Sol. Energy* 170, 454–469.
- Simo-Tagne, M., Zoulalian, A., Rémond, R., Rogaume, Y., 2018. Mathematical modelling and numerical simulation of a simple solar dryer for tropical wood using a collector. *Appl. Therm. Eng.* 131, 356–369.
- Simo-Tagne, M., Ndukwu, M.C., Zoulalian, A., Bennamoun, L., Kifani-Sahban, F., Rogaume, Y., 2019. Numerical analysis and validation of a natural convection mix-mode solar dryer for drying red chilli under variable conditions. *Renew. Energy*.
- Song, G., Shen, L., Xiao, J., 2011. Estimating specific chemical exergy of biomass from basic analysis data. *Ind. Eng. Chem. Res.* 50, 9758–9766.
- Stiling, J., Li, S., Stroeve, P., Thompson, J., Mjawa, B., Kornbluth, K., Barrett, D.M., 2012. Performance evaluation of an enhanced fruit solar dryer using concentrating panels. *Energy Sustain. Develop.* 16, 224–230.
- Tiwari, G.N., 2002. *Solar Energy Fundamentals, Design, Modeling and Applications*. Narosa Publishing House.
- Yassen, T.A., Al-Kayiem, H.H., 2016. Solar-biomass hybrid dryer enhanced by the Co-gen technique. *Dry. Technol.* 34, 287–295.