

Review Article

Decompensation of β -Cells in Diabetes: When Pancreatic β -Cells Are on ICER(R)

Roberto Salvi¹ and Amar Abderrahmani^{1,2}

¹ European Genomic Institute for Diabetes (EGID), Lille 2 University, UMR 8199, 3508 Lille, France

² Faculty of Medicine West, 1 Place de Verdun, 59045 Lille, France

Correspondence should be addressed to Amar Abderrahmani; amar.abderrahmani@univ-lille2.fr

Received 24 October 2013; Accepted 3 January 2014; Published 10 February 2014

Academic Editor: Stephane Dalle

Copyright © 2014 R. Salvi and A. Abderrahmani. This is an open access article distributed under the Creative Commons Attribution License, which permits unrestricted use, distribution, and reproduction in any medium, provided the original work is properly cited.

Insulin production and secretion are temporally regulated. Keeping insulin secretion at rest after a rise of glucose prevents exhaustion and ultimately failure of β -cells. Among the mechanisms that reduce β -cell activity is the inducible cAMP early repressor (ICER). ICER is an immediate early gene, which is rapidly induced by the cyclic AMP (cAMP) signaling cascade. The seminal function of ICER is to negatively regulate the production and secretion of insulin by repressing the genes expression. This is part of adaptive response required for proper β -cells function in response to environmental factors. Inappropriate induction of ICER accounts for pancreatic β -cells dysfunction and ultimately death elicited by chronic hyperglycemia, fatty acids, and oxidized LDL. This review underlines the importance of balancing the negative regulation achieved by ICER for preserving β -cell function and survival in diabetes.

1. Introduction

The exposure of population to overfeeding and sedentary lifestyles has increased dramatically during the last decades worldwide. This has been accompanied by a rise in the incidence of obesity and therefore the associated morbidity and mortality. These complications are related to comorbid conditions including diabetes. Insulin resistance is the most common metabolic alteration related to obesity and is considered to be a critical link between adiposity and the risk for developing diabetes. However, in most of cases, obesity does not lead to diabetes. This situation is thought to result from the capacity of β -cells to compensate for insulin resistance by releasing appropriate amount of insulin in blood probably by an increased β -cells function and mass. When the cells decompensate and thereby fail to secrete adequate insulin in the face of increased hormone demand, then there, overt diabetes comes. In this respect, identification of leading mechanisms that account for β -cells compensation and decompensation would permit to pave the way for innovative therapeutic strategies of diabetes. The present review unveils a role for the cAMP pathway target inducible cAMP early

repressor (ICER) as a central player for β -cells adaptation, which is impinged in β -cells under diabetes environmental stressors.

2. Portrait of ICER

ICER has been discovered as an inducible cAMP responsive element modulator (CREM) protein in neuroendocrine cells cultured with cAMP raising agents [1]. ICER is a small protein (<20 KDa), which contains one of the two CREM DNA-binding domains (DBDs) but without the activator and regulatory regions of the gene (Figure 1). CREM DBD I and DBD II are composed of a basic Leucine Zipper structure and have a strong homology with each other and with the unique DBD which is present on the CREB protein (Figure 1). Due to the presence of these two DBDs and to differential splicing, four ICER protein isoforms are possible. ICER I and ICER II isoforms contain, respectively, the DBD I and DBD II (Figure 1). These isoforms contain also the small exon γ of CREM gene, which instead can be missing in the two remaining isoforms: ICER I γ and ICER II γ . All four isoforms appear to be, in

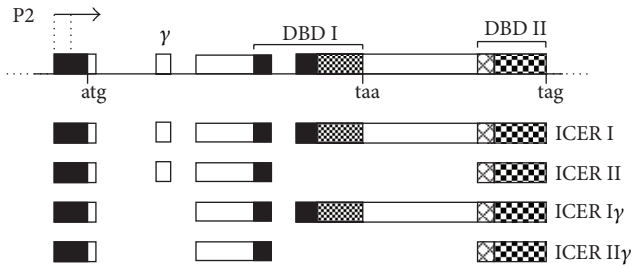

FIGURE 1: Expression of the ICER isoforms. ICER results from the P2 alternative promoter within the CREM gene. The ICER I and II isoforms are the results of alternative splicing. ICER I γ and II γ have the γ exon. DBD: DNA binding domains.

principle, functionally equivalent since they harbor one DBD. ICER binds cAMP response element (CRE) as homodimers and/or heterodimers with any member of the cAMP response element (CRE) binding protein/CRE modulator/activating factor 1 (CREB/CREM/ATF1) gene family [2–4]. Being composed of mainly the DBD, ICER can neither activate nor actively repress genes expression. However, when the expression level is high enough, it rather plays as a passive repressor by competing CREB/CREM/ATF1 transcriptional activators for binding to CRE (Figure 2). In mammalian cells there are thousands genes containing functional CRE [5, 6]. This implies that ICER is pivotal for regulation of genes expression in response to cAMP pathway.

ICER arises from the transcription of the *CREM* gene, directed via the P2 alternative internal intronic promoter [1]. The promoter contains a cluster of four CRE sites. Of note, ICER itself binds these sites and thereby represses its own promoter activity, in a negative feedback autoregulatory loop [7]. The kinetic of ICER induction is that of an immediate early gene, with transcript level peaking few hours after induction and thereafter rapidly declining. ICER is present in a wide array of different tissues such as nervous system, pituitary and pineal glands, thyroid, testis, liver, adipose tissue, pancreas, smooth muscles, skeletal muscle, cardiac muscle, bone, and cells of the immune system [8–17]. In the nervous system, especially in brain structures where a constitutive inhibition of cAMP-sensitive transcription seems to be necessary to maintain proper function, elevated basal level of ICER is required [18]. Notably, in the pineal gland, ICER is expressed in a circadian fashion, with high levels peaking during the subjective night followed by undetectable level in the subjective daylight [19]. This pattern of expression in the pineal gland is important for the transcriptional control of the rhythmic expression of arylalkylamine N-acetyltransferase, the rate-limiting enzyme controlling melatonin synthesis [20].

3. ICER as a “Brake” for Permitting Insulin Production and Secretion Return to Basal State

Insulin production, secretory function, and the rate of β -cells survival as well are regulated by the cAMP pathway. This is

exemplified by the incretin Glucagon like peptide 1 (GLP-1), which triggers a rise of cAMP and the subsequent activation of CREB [21]. As mentioned above, thousands of genes can be regulated by CREB and ICER (some relevant targets for β -cells are presented on Figure 3). One of the direct targets of CREB is the neurogenic differentiation 1 transcription factor (NeuroD), which regulates the insulin expression and the sulfonylurea receptor 1 [22]. Among the other direct targets genes there are insulin itself and components of the exocytosis apparatus such as Rab3A and Rab27A, which are members of the Rab family, and two of their effectors, slp4 and Noc2 [23, 24]. The four genes contain a functional CRE able to bind ICER [25]. Overexpression of ICER in β -cells reduces the expression of the four secretory genes. These results have led to speculate that ICER is part of adaptive mechanism allowing the expression of the components of the secretory machinery to meet the insulin production [26]. After stimulation, insulin secretion returns to basal level. Induction of ICER could be a major mechanism permitting β -cells to reduce the secretory activity, while insulin expression is diminished. This β -cells activity is required to replenish insulin within ready releasable granules for the next meal or stimulatory conditions. Connexin 36 (Cx36) is a transmembrane protein that forms gap junctions for β -cells communication [27–31]. Cx36 function is required for the control of glucose-induced insulin secretion [31]. The gene coding for Cx36 contains a CRE and is negatively regulated by ICER [31], indicating that the control in the Cx36 level by ICER participates to the dynamic regulation of glucose-induced insulin secretion. Besides of regulating β -cell function, ICER could be instrumental for controlling β -cells survivals and death. In fact, β -cells overexpression of ICER in mice impinges β -cells mass by slowing proliferation [32]. Consequently, insulin secretion is collapsed and mice have developed diabetes. Direct decrease of Cyclin A expression by ICER accounts for decline in β -cells number in transgenic mice [33]. Insulin receptor substrate 2 (IRS-2) is required for β -cells proliferation and survival. IRS-2 is a target of CREB/ICER. Expression of a CREB dominant negative in β -cells provokes diminution of IRS-2 and activation AKT signaling, thus causing β -cell dysfunction and loss of β -cell mass [34]. The mitogen activated protein kinase (MAPK) 8 interacting protein 1 (*MAPK8IP1*) gene encodes islet brain 1 (IB1) also termed as JNK interacting protein 1, a protein that tethers kinases of the JNK pathway. The IB1 function is to preserve β -cells survival, insulin expression, and secretion in response to proapoptotic stimuli by regulating the c-jun N terminal kinases (JNK) pathway [16, 35]. *MAPK8IP1* contains within its proximal regulatory region several CRE. However, only one is capable to interact with CREB and to be negatively regulated by ICER [36]. Regulation of IB1 through this sequence is crucial for the protective effect of the GLP-1 mimetic exendin-4 [37]. The protective effect of IB1 is thought to involve JNK3 activation (Figure 3).

Pancreatic β -cells express the molecular clock proteins controlling circadian rhythm of insulin secretion and impairment of some member of the clock genes such as circadian locomotor output cycles kaput (CLOCK) and brain and muscle ARNT-like 1 (BMAL1), leading to hypoinsulinemia and

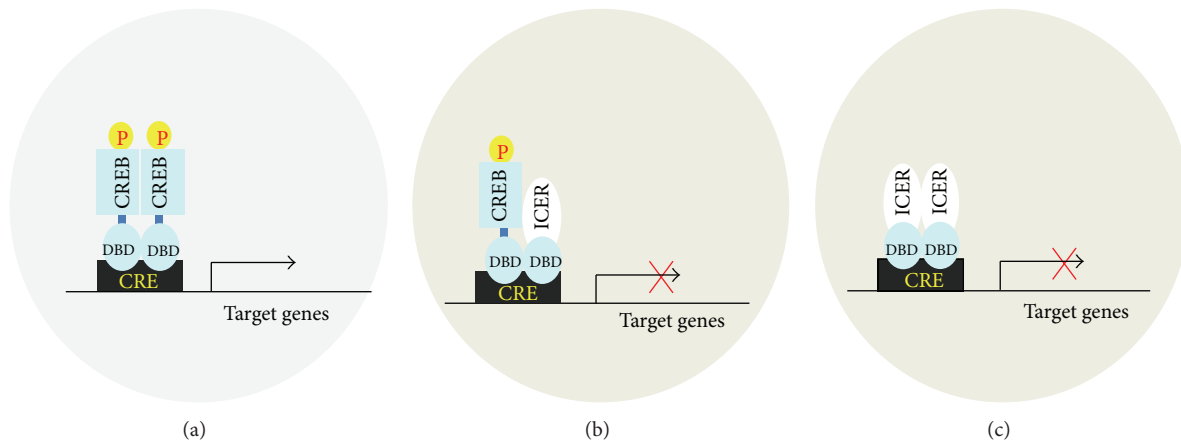

FIGURE 2: Schematic model for function of the passive repressor ICER. (a) Binding of CREB to CRE occurs when CREB is phosphorylated and the level of ICER is low. CREB can either homodimerize or form heterodimers with other activators, thereby activating gene expression. ICER competes with CREB for binding to CRE when it reaches a certain level. In this case, ICER can either (b) heterodimerize with CREB or (c) homodimerize.

diabetes [38–41]. CLOCK and BMAL1 work through interwoven positive and negative feedback loops [42]. The two proteins form heterodimers that activate transcription of the genes coding for Period (PER) and Cryptochrome (CRY). PER/CRY heterodimers form the negative limb, which in turn inhibits the activity of CLOCK/BMAL1, thereby generating circadian rhythms of transcription/translation. At the heart of the system is the ability of CLOCK/BMAL1 heterodimers to recognize and bind the E-Box elements which are present on the promoters of both *Per* and *Cry* genes. In addition to the E-Box, *Per1* and *Per2* genes contain functional CRE elements [39, 40]. Regulation of these genes by CREB is important for the fine tuning and modulation of clock genes in response to changing environmental cues. For instance, CREB-mediated upregulation of the *Per1* gene in the suprachiasmatic nucleus neurons is required for the photic resetting that takes place during the dark-light circadian transitions [43, 44]. Moreover, CREB plays another important role in the modulation of the molecular clocks in peripheral organs, especially in the liver where it is implicated in the control of gluconeogenesis [45, 46]. Interestingly, recent data show that ICER regulates the *Per1* gene in hepatic and adrenal gland clocks [47] and such regulation could account for circadian melatonin production in the pineal gland [19]. In view of these findings, it is possible that such a mechanism could take place in β -cells but this remains to be addressed.

4. Deregulation of ICER in Response to Environmental Stressors Associated with Diabetes

Typically, ICER activity results from a rise of its expression. Repression of target genes ensues when the expression of ICER reaches appropriate amount for competing CREB, CREM, and eventually ATF for binding to CRE (Figure 2). Such regulation could represent an adaptive mechanism for cells to return to their basal state after stimulation. In this

respect, it is predictable that deregulation in the levels of ICER could strikingly perturb β -cells function and thereby glucose homeostasis. Several lines of evidence seem to argue in favor of such hypothesis. The first clue comes from a study carried out on Goto-Kakizaki (GK) rats, a well-characterized model of genetic nonobese type 2 diabetes in which β -cells function is impaired [48]. Isolated islets from these rats display high levels of CREM repressor including ICER I, indicating that the increase of ICER could contribute to β -cell dysfunction. Insulin secretion usually increases as the consequence of insulin resistance. However, glucose sensitivity of β -cells can fail to overcome insulin demand overtime. In this case overt diabetes appears. In islets of obese mice fed with a HFD, increase in the ICER level has been monitored [49]. Obesity is characterized by chronic elevation of nonesterified free fatty acids (NEFAs) including the saturated NEFA palmitate [50]. Chronic hyperglycemia resulting both from insulin resistance and glycemic excursion from the meal can also appear in obesity. There are clues that palmitate and chronic hyperglycemia may account for the increase of ICER in defective β -cells in obese animals. Prolonged elevation of palmitate and glucose, individually, hampers insulin secretion in human individuals and exerts harmful effects in β -cells. *In vitro* experiments have unveiled that increase in ICER is partly responsible of the adverse effects elicited by both diabetogenic factors.

Modification in the lipoproteins level is observed in obese individuals and is hallmark of metabolic syndrome. Increased levels of oxidized LDL-cholesterol particles together with a decrease in plasma concentration of HDL particles are seen at present as additional potential diabetogenic stressors, while they increase the risks of patients for developing cardiovascular diseases. Low plasma level of HDL and specific antibodies against oxidized LDL are found in patients with T2D. Perturbations in the two lipoproteins are further already observed in metabolic syndrome and they are worse throughout the duration of diabetes. Infusion of recombinant HDL in patients with T2D reduces glycemia by an increase in insulin secretion

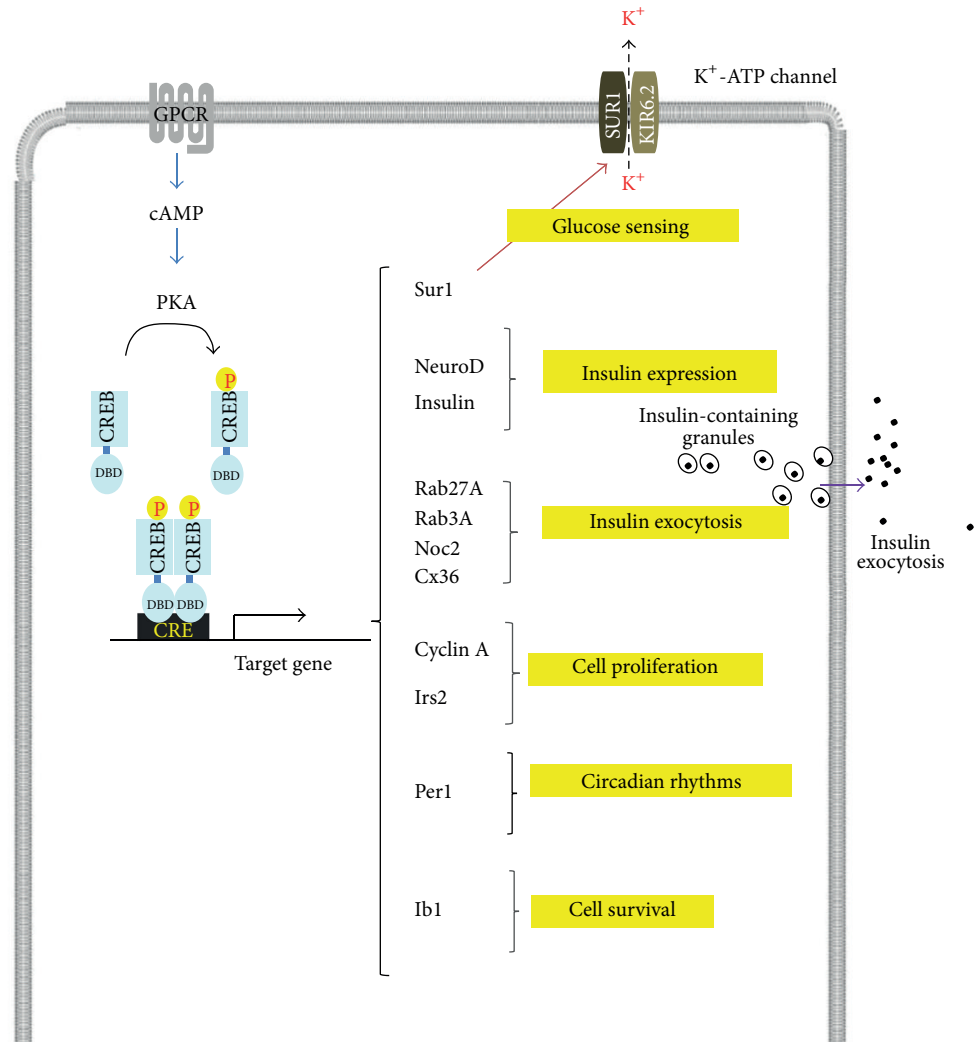

FIGURE 3: Target genes regulated by CREB and ICER in pancreatic β -cells. Typically phosphorylation of CREB results from the protein kinase A (PKA) activity. PKA activity is stimulated by the G protein coupled receptor-induced increase of cAMP. Some genes regulated by CREB and consequently ICER are listed in the schema. Sur1: sulfonylurea receptor 1; neurogenic differentiation 1: NeuroD; Irs2: insulin receptor 2; Per1: Period 1; Ib1: islet brain 1; Noc2: no C2 domain protein, Cx36: Connexin 36.

and glucose uptake in muscles. Improvement in insulin secretion results from cytoprotective properties of HDL by at least tackling the effects of oxidized LDL. The human modified LDL augments the expression of ICER via oxidative stress [51]. Consequently, elevation of ICER elicited by oxidized LDL cholesterol hampers insulin production and glucose-induced secretion by affecting Rab3A, Rab27A, Slp4, and Noc2. Finally cells cultured with the human oxidized LDL undergo apoptosis because of reduced expression of IB1 and JNK activity.

Transgenic mice that specifically overexpress ICER in β -cells exhibit high blood glucose levels throughout their lifespan and mice died from severe diabetes because of a reduced functional β -cell mass [32]. Chronic hyperglucagonemia usually parallels defective insulin secretion in diabetes. Glucagon acts through stimulation of the cAMP/PKA pathway, resulting in activation of CREB. As the consequence of CREB

activity, the expression of ICER is induced, resulting in repression of the insulin gene transcription [52]. Induction of ICER by hyperglucagonemia may represent an additional mechanism contributing to deregulated insulin gene expression and β -cells failure in diabetes.

5. Concluding Remarks and Perspectives

While ICER represses target genes, it inhibits its own promoter as well. This negative feedback loop permits genes expression and ICER as well, returning to basal state. Elevation of ICER observed in islets β -cells exposed to diabetes environmental conditions raises the idea that destruction of ICER is a key for counteracting β -cell failure. This hypothesis is not possible if a systemic approach for silencing ICER in the body is employed. Decline of ICER is detrimental, at least for adipose function and systemic insulin sensitivity. Drastic

reduction in the adipose ICER content, as observed in both obese human and mice, impairs insulin-induced glucose uptake and production of the insulin sensitizer adiponectin [16, 51]. Drop of adiponectin, if protracted in the long term, has adverse effects for systemic insulin sensitivity [53]. A careful examination in the mechanism leading to uncontrolled expression of ICER in β -cells needs therefore to be considered. With this regard, the rise of ICER may result either from increased activators activity or defect of the negative autoregulation. The P2 promoter activity is under the control of CREB. In β -cells exposed to chronic hyperglycemia the CREB level is reduced via proteasomal degradation [54]. A role for CREB in the increased production of ICER seems therefore unlikely. Future studies will be to investigate whether negative regulators are missing or rather some activators are stimulated in diabetes condition to promote sustained expression of ICER. Identification of these mechanisms would pave the way for identification of innovative therapeutic counteracting β -cells dysfunction and death in diabetes.

Conflict of Interests

The authors of this paper have no conflict of interests.

Acknowledgments

This work was supported by the Chair of Excellence from the French National Agency for Research no. ANR-10-CEXC-005-01, the Regional Council Nord Pas de Calais, and the European Regional Development Fund.

References

- [1] C. A. Molina, N. S. Foulkes, E. Lalli, and P. Sassone-Corsi, "Inducibility and negative autoregulation of CREM: an alternative promoter directs the expression of ICER, an early response repressor," *Cell*, vol. 75, no. 5, pp. 875–886, 1993.
- [2] W. A. Sands and T. M. Palmer, "Regulating gene transcription in response to cyclic AMP elevation," *Cellular Signalling*, vol. 20, no. 3, pp. 460–466, 2008.
- [3] G. M. Fimia, D. de Cesare, and P. Sassone-Corsi, "A family of LIM-only transcriptional coactivators: tissue-specific expression and selective activation of CREB and CREM," *Molecular and Cellular Biology*, vol. 20, no. 22, pp. 8613–8622, 2000.
- [4] T. Hai and M. G. Hartman, "The molecular biology and nomenclature of the activating transcription factor/cAMP responsive element binding family of transcription factors: activating transcription factor proteins and homeostasis," *Gene*, vol. 273, no. 1, pp. 1–11, 2001.
- [5] M. D. Conkright, E. Guzmán, L. Flechner, A. I. Su, J. B. Hogenesch, and M. Montminy, "Genome-wide analysis of CREB target genes reveals a core promoter requirement for cAMP responsiveness," *Molecular Cell*, vol. 11, no. 4, pp. 1101–1108, 2003.
- [6] X. Zhang, D. T. Odom, S.-H. Koo et al., "Genome-wide analysis of cAMP-response element binding protein occupancy, phosphorylation, and target gene activation in human tissues," *Proceedings of the National Academy of Sciences of the United States of America*, vol. 102, no. 12, pp. 4459–4464, 2005.
- [7] D. de Cesare and P. Sassone-Corsi, "Transcriptional regulation by cyclic AMP-responsive factors," *Progress in Nucleic Acid Research and Molecular Biology*, vol. 64, pp. 343–369, 2000.
- [8] E. Lalli and P. Sassone-Corsi, "Thyroid-stimulating hormone (TSH)-directed induction of the CREM gene in the thyroid gland participates in the long-term desensitization of the TSH receptor," *Proceedings of the National Academy of Sciences of the United States of America*, vol. 92, no. 21, pp. 9633–9637, 1995.
- [9] J. Bodor, Z. Fehervari, B. Diamond, and S. Sakaguchi, "ICER/CREM-mediated transcriptional attenuation of IL-2 and its role in suppression by regulatory T cells," *European Journal of Immunology*, vol. 37, no. 4, pp. 884–895, 2007.
- [10] H. Ohtsubo, T. Ichiki, R. Miyazaki et al., "Inducible cAMP early repressor inhibits growth of vascular smooth muscle cell," *Arteriosclerosis, Thrombosis, and Vascular Biology*, vol. 27, no. 7, pp. 1549–1555, 2007.
- [11] J. M. Nervina, S. Tetradis, Y.-F. Huang, D. Harrison, C. Molina, and B. E. Kream, "Expression of inducible cAMP early repressor is coupled to the cAMP-protein kinase A signaling pathway in osteoblasts," *Bone*, vol. 32, no. 5, pp. 483–490, 2003.
- [12] X. Wang and T. J. Murphy, "The inducible cAMP early repressor ICERII γ inhibits CREB and AP-1 transcription but not AT1 receptor gene expression in vascular smooth muscle cells," *Molecular and Cellular Biochemistry*, vol. 212, no. 1-2, pp. 111–119, 2000.
- [13] G. Servillo, M. A. Della Fazio, and P. Sassone-Corsi, "Coupling cAMP signaling to transcription in the liver: pivotal role of CREB and CREM," *Experimental Cell Research*, vol. 275, no. 2, pp. 143–154, 2002.
- [14] J. H. Stehle, C. von Gall, and H.-W. Korf, "Analysis of cell signalling in the rodent pineal gland deciphers regulators of dynamic transcription in neural/endocrine cells," *European Journal of Neuroscience*, vol. 14, no. 1, pp. 1–9, 2001.
- [15] C. Mazzucchelli and P. Sassone-Corsi, "The inducible cyclic adenosine monophosphate early repressor (ICER) in the pituitary intermediate lobe: role in the stress response," *Molecular and Cellular Endocrinology*, vol. 155, no. 1-2, pp. 101–113, 1999.
- [16] S. Brajkovic, R. Marenzoni, D. Favre et al., "Evidence for tuning adipocytes ICER levels for obesity care," *Adipocyte*, vol. 1, no. 3, pp. 157–160, 2012.
- [17] A. Inada, Y. Someya, Y. Yamada et al., "The cyclic AMP response element modulator family regulates the insulin gene transcription by interacting with transcription factor IID," *The Journal of Biological Chemistry*, vol. 274, no. 30, pp. 21095–21103, 1999.
- [18] C. A. Kell, F. Dehghani, H. Wicht, C. A. Molina, H.-W. Korf, and J. H. Stehle, "Distribution of transcription factor inducible cyclic AMP early repressor (ICER) in rodent brain and pituitary," *Journal of Comparative Neurology*, vol. 478, no. 4, pp. 379–394, 2004.
- [19] N. S. Foulkes, J. Borjigin, S. H. Snyder, and P. Sassone-Corsi, "Rhythmic transcription: the molecular basis of circadian melatonin synthesis," *Trends in Neurosciences*, vol. 20, no. 10, pp. 487–492, 1997.
- [20] G. Sarlak, A. Jenwitheesuk, B. Chetsawang, and P. Govitrapong, "Effects of melatonin on nervous system aging: neurogenesis and neurodegeneration," *Journal of Pharmacological Sciences*, vol. 123, pp. 9–24, 2013.
- [21] S. van de Velde, M. F. Hogan, and M. Montminy, "mTOR links incretin signaling to HIF induction in pancreatic beta cells," *Proceedings of the National Academy of Sciences of the United States of America*, vol. 108, no. 41, pp. 16876–16882, 2011.

- [22] I.-S. Cho, M. Jung, K.-S. Kwon et al., "Deregulation of CREB signaling pathway induced by chronic hyperglycemia downregulates NeuroD transcription," *PLoS ONE*, vol. 7, no. 4, Article ID e34860, 2012.
- [23] D. Melloul, S. Marshak, and E. Cerasi, "Regulation of insulin gene transcription," *Diabetologia*, vol. 45, no. 3, pp. 309–326, 2002.
- [24] A. Abderrahmani, V. Plaisance, P. Lovis, and R. Regazzi, "Mechanisms controlling the expression of the components of the exocytotic apparatus under physiological and pathological conditions," *Biochemical Society Transactions*, vol. 34, no. 5, pp. 696–700, 2006.
- [25] A. Abderrahmani, S. Cheviet, M. Ferdaoussi, T. Coppola, G. Waeber, and R. Regazzi, "ICER induced by hyperglycemia represses the expression of genes essential for insulin exocytosis," *The EMBO Journal*, vol. 25, no. 5, pp. 977–986, 2006.
- [26] A. Abderrahmani, "Adaptation of the secretory machinery to pathophysiological conditions," in *Molecular Mechanisms of Exocytosis*, R. Regazzi, Ed., pp. 161–173, Springer, New York, NY, USA, 2007.
- [27] F. Allagnat, F. Alonso, D. Martin, A. Abderrahmani, G. Waeber, and J.-A. Haefliger, "ICER-1 γ overexpression drives palmitate-mediated connexin36 down-regulation in insulin-secreting cells," *The Journal of Biological Chemistry*, vol. 283, no. 9, pp. 5226–5234, 2008.
- [28] J. A. Haefliger, D. Martin, D. Favre et al., "Reduction of connexin36 content by ICER-1 contributes to insulin-secreting cells apoptosis induced by oxidized LDL particles," *PLoS ONE*, vol. 8, no. 1, Article ID e55198, 2013.
- [29] J. A. Haefliger, F. Rohner-Jeanrenaud, D. Caille, A. Charollais, P. Meda, and F. Allagnat, "Hyperglycemia downregulates Connexin36 in pancreatic islets via the upregulation of ICER-1/ICER-1 γ ," *Journal of Molecular Endocrinology*, vol. 51, no. 1, pp. 49–58, 2013.
- [30] F. Allagnat, D. Martin, D. F. Condorelli, G. Waeber, and J.-A. Haefliger, "Glucose represses connexin36 in insulin-secreting cells," *Journal of Cell Science*, vol. 118, no. 22, pp. 5335–5344, 2005.
- [31] V. Cigliola, V. Chellakudam, W. Arabieter, and P. Meda, "Connexins and β -cell functions," *Diabetes Research and Clinical Practice*, vol. 99, no. 3, pp. 250–259, 2013.
- [32] A. Inada, Y. Hamamoto, Y. Tsuura et al., "Overexpression of inducible cyclic AMP early repressor inhibits transactivation of genes and cell proliferation in pancreatic β cells," *Molecular and Cellular Biology*, vol. 24, no. 7, pp. 2831–2841, 2004.
- [33] A. Inada, G. C. Weir, and S. Bonner-Weir, "Induced ICER 1 γ down-regulates cyclin a expression and cell proliferation in insulin-producing β cells," *Biochemical and Biophysical Research Communications*, vol. 329, no. 3, pp. 925–929, 2005.
- [34] U. S. Jhala, G. Canettieri, R. A. Screaton et al., "cAMP promotes pancreatic β -cell survival via CREB-mediated induction of IRS2," *Genes and Development*, vol. 17, no. 13, pp. 1575–1580, 2003.
- [35] D. Favre, G. Niederhauser, D. Fahmi et al., "Role for inducible cAMP early repressor in promoting pancreatic beta cell dysfunction evoked by oxidative stress in human and rat islets," *Diabetologia*, vol. 54, no. 9, pp. 2337–2346, 2011.
- [36] A. Abderrahmani, M. Steinmann, V. Plaisance et al., "The transcriptional repressor REST determines the cell-specific expression of the human MAPK8IP1 gene encoding I β 1 (JIP-1)," *Molecular and Cellular Biology*, vol. 21, no. 21, pp. 7256–7267, 2001.
- [37] M. Ferdaoussi, S. Abdelli, J.-Y. Yang et al., "Exendin-4 protects β -cells from interleukin-1 β -induced apoptosis by interfering with the c-Jun NH2-terminal kinase pathway," *Diabetes*, vol. 57, no. 5, pp. 1205–1215, 2008.
- [38] B. Marcheiva, K. M. Ramsey, E. D. Buhr et al., "Disruption of the clock components CLOCK and BMAL1 leads to hypoinsulinaemia and diabetes," *Nature*, vol. 466, no. 7306, pp. 627–631, 2010.
- [39] L. A. Sadacca, K. A. Lamia, A. S. deLemos, B. Blum, and C. J. Weitz, "An intrinsic circadian clock of the pancreas is required for normal insulin release and glucose homeostasis in mice," *Diabetologia*, vol. 54, no. 1, pp. 120–124, 2011.
- [40] J. Lee, M.-S. Kim, R. Li et al., "Loss of Bmal1 leads to uncoupling and impaired glucose-stimulated insulin secretion in β -cells," *Islets*, vol. 3, no. 6, pp. 381–388, 2011.
- [41] J. Yoshino and S.-I. Imai, "A clock ticks in pancreatic β cells," *Cell Metabolism*, vol. 12, no. 2, pp. 107–108, 2010.
- [42] C. L. Partch, C. B. Green, and J. S. Takahashi, "Molecular architecture of the mammalian circadian clock," *Trends in Cell Biology*, vol. 23, pp. 1–10, 2013.
- [43] Y. Naruse, K. Oh-Hashi, N. Iijima, M. Naruse, H. Yoshioka, and M. Tanaka, "Circadian and light-induced transcription of clock gene Per1 depends on histone acetylation and deacetylation," *Molecular and Cellular Biology*, vol. 24, no. 14, pp. 6278–6287, 2004.
- [44] A. Jagannath, R. Butler, S. I. H. Godinho et al., "The CRTCI-SIK1 pathway regulates entrainment of the circadian clock," *Cell*, vol. 154, no. 5, pp. 1100–1111, 2013.
- [45] C. Vollmers, S. Gill, L. DiTacchio, S. R. Pulivarthy, H. D. Le, and S. Panda, "Time of feeding and the intrinsic circadian clock drive rhythms in hepatic gene expression," *Proceedings of the National Academy of Sciences of the United States of America*, vol. 106, no. 50, pp. 21453–21458, 2009.
- [46] E. E. Zhang, Y. Liu, R. Dentin et al., "Cryptochrome mediates circadian regulation of cAMP signaling and hepatic gluconeogenesis," *Nature Medicine*, vol. 16, no. 10, pp. 1152–1156, 2010.
- [47] U. P. Zmrzljak, A. Korencic, R. Kosir, M. Golicnic, P. Sassone-Corsi, and D. Rozman, "Inducible cAMP early repressor regulates the Period 1 gene of the hepatic and adrenal clocks," *The Journal of Biological Chemistry*, vol. 288, pp. 10318–10327, 2013.
- [48] A. Inada, Y. Yamada, Y. Someya et al., "Transcriptional repressors are increased in pancreatic islets of type 2 diabetic rats," *Biochemical and Biophysical Research Communications*, vol. 253, no. 3, pp. 712–718, 1998.
- [49] D. Favre, E. le Gouill, D. Fahmi et al., "Impaired expression of the inducible cAMP early repressor accounts for sustained adipose CREB activity in obesity," *Diabetes*, vol. 60, no. 12, pp. 3169–3174, 2011.
- [50] G. Boden and G. I. Shulman, "Free fatty acids in obesity and type 2 diabetes: defining their role in the development of insulin resistance and β -cell dysfunction," *European Journal of Clinical Investigation*, vol. 32, supplement 3, pp. 14–23, 2002.
- [51] A. Abderrahmani, G. Niederhauser, D. Favre et al., "Human high-density lipoprotein particles prevent activation of the JNK pathway induced by human oxidised low-density lipoprotein particles in pancreatic beta cells," *Diabetologia*, vol. 50, no. 6, pp. 1304–1314, 2007.
- [52] M. A. Hussain, P. B. Daniel, and J. F. Habener, "Glucagon stimulates expression of the inducible cAMP early repressor and suppresses insulin gene expression in pancreatic β -cells," *Diabetes*, vol. 49, no. 10, pp. 1681–1690, 2000.

- [53] L. Qi, M. Saberi, E. Zmuda et al., "Adipocyte CREB promotes insulin resistance in obesity," *Cell Metabolism*, vol. 9, no. 3, pp. 277–286, 2009.
- [54] S. Costes, B. Vandewalle, C. Turrel-Cuzin et al., "Degradation of cAMP-responsive element-binding protein by the ubiquitin-proteasome pathway contributes to glucotoxicity in β -cells and human pancreatic islets," *Diabetes*, vol. 58, no. 5, pp. 1105–1115, 2009.