

BMJ Open Hypofractionated versus conventional intensity-modulated radiation irradiation (HARVEST-adjuvant): study protocol for a randomised non-inferior multicentre phase III trial

Jinrong Xie ¹, Feifei Xu,¹ Yutian Zhao,² Gang Cai,¹ Xiao Lin,^{3,4} Qiwei Zhu,⁵ Qing Lin,⁶ Yuan Yao,⁷ Cheng Xu,¹ Rong Cai,¹ Shubei Wang,¹ Xiaolu Tang,¹ Chuying Chen,¹ Siyue Zheng,¹ Mei Chen,¹ Min Chen,¹ Xiaofang Qian,¹ Chunhong Shen,¹ Jian Li,⁸ Haoping Xu,¹ Fei Xu,¹ Yimin Han,¹ Min Li,¹ Dan Ou,¹ Kun Wei Shen,⁹ Wei-Xiang Qi,¹ Lu Cao,¹ Xiaobo Huang,^{3,4,10} Jiayi Chen¹

To cite: Xie J, Xu F, Zhao Y, *et al.* Hypofractionated versus conventional intensity-modulated radiation irradiation (HARVEST-adjuvant): study protocol for a randomised non-inferior multicentre phase III trial. *BMJ Open* 2022;**12**:e062034. doi:10.1136/bmjopen-2022-062034

► Prepublication history and additional supplemental material for this paper are available online. To view these files, please visit the journal online (<http://dx.doi.org/10.1136/bmjopen-2022-062034>).

Received 17 February 2022
Accepted 09 August 2022



© Author(s) (or their employer(s)) 2022. Re-use permitted under CC BY-NC. No commercial re-use. See rights and permissions. Published by BMJ.

For numbered affiliations see end of article.

Correspondence to
Professor Jiayi Chen;
cyj11756@rjh.com.cn

ABSTRACT

Introduction Short course regimen has become the major trend in the field of adjuvant radiotherapy for patients with breast cancer. Hypofractionated radiotherapy (HF-RT) regimen of 40–42.5 Gy in 15–16 fractions has been established as a preferred option for whole breast irradiation. However, few evidences of hypofractionated regional nodal irradiation (RNI), especially involving internal mammary nodes (IMNs), could be available during the era of intensity-modulated radiation therapy (IMRT). Against this background, we design this trial to explore the hypothesis that HF-RT regimen involving RNI (including infraclavicular, supraclavicular nodes and IMNs) will be non-inferior to a standard schedule by using IMRT technique.

Methods and analysis This is an open-label randomised, non-inferior, multicentre phase III trial. Patients with breast cancer with an indication for RNI after breast conserving surgery or mastectomy are randomised at a ratio of 1:1 into the following two groups: hypofractionated regimen of 2.67 Gy for 16 fractions or conventional regimen of 2 Gy for 25 fractions. The dose was prescribed to ipsilateral chest wall or whole breast and RNI (including infraclavicular, supraclavicular nodes and IMNs, lower axilla if indicated). The trial plans to enrol a total of 801 patients and all patients will be treated using IMRT technique. The primary endpoint is 5-year locoregional recurrence. The secondary endpoints include 5-year distant metastasis free survival, invasive recurrence-free survival, overall survival, accumulative acute radiation-induced toxicity and accumulative late radiation-induced toxicity, cosmetic outcomes and quality of life.

Ethics and dissemination The study has been approved by the Ethical Committee of Ruijin Hospital affiliated to Shanghai Jiao Tong University School of Medicine (version 2018-95-3) and approvals from ethical committee of each participating centre have also been obtained. Research findings will be submitted for publication in peer-reviewed journals.

Trial registration number NCT03829553.

STRENGTHS AND LIMITATIONS OF THIS STUDY

- ⇒ This is the first trial to explore efficacy and safety of hypofractionated radiotherapy regimen of 40 Gy in 15 fractions in patients treated with regional nodal irradiation (including internal mammary nodes) in China.
- ⇒ The design of the trial as an open-labelled, randomised, non-inferior, multicentre phase III trial will enhance the strength of the trial and reduce bias.
- ⇒ In this trial, all the comprehensive nodal regions are treated with the ipsilateral breast/chest-wall as an integrated planning target with modern intensity-modulated radiation therapy technique to confirm the safety of internal mammary node irradiation.
- ⇒ One of the limitations is that this study does not stratify according to clinicopathological, subtype or gene information.

INTRODUCTION

Globally, breast cancer is the most common cancer (11.6% of the total cases) and fifth leading cause of cancer death (627 000 deaths) in women.¹ Adjuvant regional nodal irradiation (RNI) has been proved to significantly reduce any first recurrence and improve breast cancer-specific survival in high-risk patients with breast cancer.^{2–7} The standard regimen of RNI is 45–50 Gy in 25–28 fractions and with a sequential tumour bed boost of 10–16 Gy in 5–8 fractions in patients treated with breast conserving surgery (BCS). The overall treatment course is up to 5–7 weeks, which brings great inconvenience to patients such that some patients choose mastectomy even if they are indicated to BCS or declined adjuvant radiotherapy (RT) after

BCS. Long course of RT also aggravates the shortage of RT facilities.

The α/β value is a well-established radiobiological parameter to quantify the sensitivity of normal or malignant tissue to fraction size, with lower than 10 Gy indicating higher sensitivity to fraction size. Yarnold *et al*⁸ have demonstrated an α/β value of 3.6 Gy for any change in breast appearance and 3.1 Gy for palpable breast induration after a minimum 5-year follow-up for 1410 patients with invasive breast cancer. Similarly, a meta-analysis of the Standardisation of Breast Radiotherapy (START) pilot trial and the START-A trial provided an adjusted α/β value for local-regional relapse of 3.5 Gy, and α/β estimates for normal tissue endpoints in START-A were around 4 Gy after a 10-year follow-up.⁹ Based on radiobiological theory and results of previous studies, breast cancer should be more sensitive to hypofractionation with more than 2 Gy of fraction size. Until now, the efficacy and safety of hypofractionated (HF) whole breast irradiation (WBI) has been confirmed by a series of studies including randomised controlled trials with long-term follow-up and real-world studies as well.^{9–14} Moderate HF regimen of 40–42.5 Gy in 15–16 fractions has been established as preferred regimen for WBI in international guidelines and clinical practice.^{15–17} Recently, the FAST-FORWARD trial further confirmed that 1-week schedule of 26 Gy in five fractions is non-inferior to standard 3-week regimen of 40 Gy in 15 fractions for 5-year local tumour control and similar in terms of late adverse effects in patients treated with WBI alone.¹⁸

Compared with the maturity of moderate HF in WBI alone, the evidence supporting hypofractionated RNI (HF-RNI) is limited, while its potential benefit attracts increasing concern.^{19–22} The safety and efficacy of hypofractionated radiotherapy (HF-RT) has been preliminarily explored in some previous studies.^{23–26} The only published randomised trial has demonstrated that HF-RNI of 43.5 Gy in 15 fractions was non-inferior to standard regimen of 50 Gy in 25 fractions in terms of locoregional control and acute or late adverse effects after a median follow-up of 58.5 months in patients receiving mastectomy.²⁴ All patients enrolled in the study were treated with single low-energy electron beam, and internal mammary nodes (IMNs) were not included in the field of RNI. Neither patients receiving neo-adjuvant systemic therapy nor those with breast reconstruction were enrolled in the study.

Recent meta-analysis of RNI presented by Early Breast Cancer Trialists' Collaborative Group (EBCTCG) showed that improvement in any recurrence, breast cancer mortality and overall mortality associated with RNI only existed in 'newer trials' which is defined as a better coverage of target volume and lower mean dose of heart (<8 Gy) since 1989 but not in 'older trials'.²⁷ Our previous studies reported the experience of treating chest wall/whole breast and regional nodes as a whole planning treating volume (PTV) using intensity-modulated radiation therapy (IMRT) technique which brought good PTV

coverage with homogeneity and reduce dose of heart and lung.^{28 29}

With aforementioned background, there is a lack of evidence in current guidelines to support HF-RNI using modern radiotherapeutic technique, adapting current therapeutic strategy. Our current study is an open-labelled, randomised, non-inferior, multicentre phase III trial (Hypofractionated irradiation At Regional nodal area for breast cancer vs Existed Standard Treatment, short name as HARVEST). Our hypothesis is that HF-RT regimen of 40 Gy in 15 fractions is at least as safe and as effective as standard regimen of 50 Gy in 25 fractions in patients treated with RNI using IMRT technique.

METHODS

Study Design

The HARVEST trial is an open-label, randomised, non-inferior, multicentre phase III trial in China. The main objective of this trial is to investigate the hypothesis that HF-RT regimen of 40 Gy in 15 fractions involving RNI (including infraclavicular, supraclavicular nodes and IMNs) will be non-inferior to a standard schedule of 50 Gy in 25 fractions by using IMRT technique among breast cancer treated with mastectomy or BCS. Eligible patients will be randomly assigned in a 1:1 ratio to receive either HF-RT or conventional fractionated RT. Irradiation is delivered to ipsilateral chest wall or whole breast with regional lymphatic regions (supra/infraclavicular nodes and IMN in each patient, lower axilla if indicated). Eligible patients will be followed for at least 5 years. The primary endpoint is 5-year locoregional recurrence rate (LRR). The secondary endpoints include 5-year distant metastasis free survival (DMFS), invasive recurrence-free survival (IRFS), overall survival (OS), accumulative acute radiation-induced toxicity and accumulative late radiation-induced toxicity, cosmetic outcomes and quality of life. Study design is shown in figure 1.

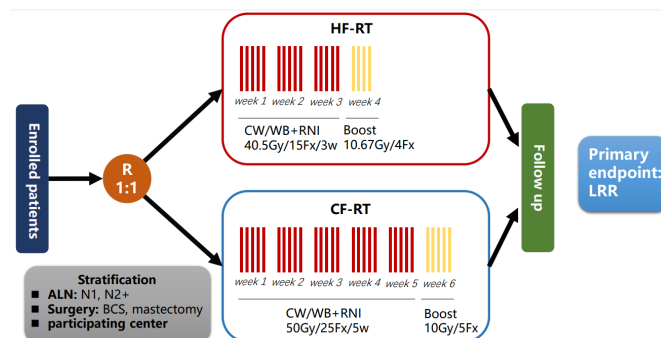

Figure 1 Study design of HARVEST. ALN, axillary lymph nodes; BCS, breast conserving surgery; CF-RT, conventional radiotherapy; CW, chest wall; HF-RT, hypofractionated radiotherapy; LRR, local regional recurrence; R, randomisation; RNI, regional nodes irradiation; w, weeks; WB, whole breast.

Randomisation

Prior to randomisation, the eligibility electronic edition of case report form (eCRF) must be completed and informed consent must be obtained from patients. Randomisation will be generated via a computer-generated random numbers sequence using SPSS software V.21.0 (IBM Corporation, Armonk, New York, USA), stratified by participating centre, type of primary surgery (BCS or mastectomy) and numbers of positive axillary lymph nodes (1–3 or ≥ 4). The specific trained staff in Ruijin Hospital affiliated to Shanghai Jiaotong University School of Medicine is responsible for the randomisation process and provide patient's unique randomisation number (Trial ID) to investigators. Allocation concealment should be ensured, as the service will not release the randomisation group until the patient has been recruited into the trial, which takes place after all baseline measurements have been completed. Given the nature of intervention used in the study, no blinding is planned in this study.

Participants and recruitment

Patients will be recruited by radiation oncologists in each study centre. For each potential participant, the background of this trial will be introduced by the clinicians or research nurses at their first visit.

The specific designed manual of this trial will be given to every enrolled patient before they signed the informed consent. Research nurses are responsible for keeping the enrolled patients informed of their treatment and follow-up schedule so as to improve their compliance to the protocol.

The first patient was enrolled on the 21 February 2019 and accrual is expected to last for 3 years (tentatively till December 2022). As the primary endpoint is a 5-year rate of LRR, the final data of collection for the primary outcome measure is expected to be December 2027.

Inclusion and exclusion criteria for the trial

Patients who meet the following criteria will be enrolled in the trial:

- ▶ Age 18–75 years old.
- ▶ Unilateral histologically confirmed invasive breast carcinoma of pT1–3.
- ▶ Breast conserving surgery or mastectomy.
- ▶ Breast reconstruction is allowed.
- ▶ Histologically confirmed positive axillary lymph nodes (positive sentinel lymph nodes without axillary dissection is allowed).
- ▶ Life expectancy of >5 years.
- ▶ A minimum negative surgical margin width of >2 mm.
- ▶ Karnofsky Performance Status ≥ 80 .
- ▶ Estrogen-receptor, progesterone-receptor, human epidermal growth factor receptor-2 (HER-2) and Ki-67 index can be performed on the primary breast tumour or axillary nodes.
- ▶ Written informed consent.

Patients who meet the following criteria will be excluded from the trial:

- ▶ Supraclavicular lymph nodes, positive ipsilateral internal mammary lymph nodes or residual axillary nodes that may be eligible for a boost dose.
- ▶ Pregnant or lactating.
- ▶ Severe non-neoplastic medical comorbidities.
- ▶ Diagnosis of non-breast malignancy within 5 years preceding enrollment (except for basal cell carcinoma of the skin or carcinoma in situ of the cervix).
- ▶ Simultaneous contralateral breast cancer.
- ▶ Previous RT to thoracic and/or axillary, cervical region.
- ▶ Active collagen vascular disease.
- ▶ Evidence of distant metastatic disease and/or T4 disease.

Notes:

1. Patients with severe non-neoplastic medical comorbidities (eg, severe ischaemic heart disease, severe arrhythmia or severe chronic obstructive pulmonary disease) that would preclude radiation treatment will be excluded.
2. Simultaneous contralateral breast cancer includes histologically confirmed pure ductal carcinoma in situ.

Radiotherapy

General consideration

RT should be started within 12 weeks of the last date of surgery or within 8 weeks of last dose of planned adjuvant chemotherapy. The irradiation fields of RNI include supra/infraclavicular nodes and IMN and axilla if indicated. Planned adjuvant endocrine therapy and anti-HER-2 therapy are allowed to continue during the course of RT.

Patient positioning and immobilisation

Patients are positioned supine with both arms abducted (90° or greater) and elevated by a breast board. CT-based treatment planning with scan thickness of 3–5 mm should start at the level of the cranial base to at least 4 cm below the ipsilateral or contralateral inframammary fold. At simulation, the surgical scar should be routinely wired with radiopaque marker.

Volumes of interest

The clinical target volume (CTV) and organs at risk (OAR) must be contoured on all CT slices when these structures are visible based on Radiation Therapy Oncology Group (RTOG) contouring guidelines.³⁰ In this trial, comprehensive RNI commonly includes supra/infraclavicular nodes and IMNs. Delineation of medial supraclavicular nodes is necessary for all enrolled patients while contouring of lateral supraclavicular nodes is only indicated for patients with the pN2–3 stage. Infraclavicular lymph nodes include axilla level III, rotter's nodes and part of axilla level II without dissection in surgery. For patients with pathological positive sentinel lymph nodes and without subsequent axillary dissection, delineation of axillary levels I and II are indicated when the risk of non-sentinel axillary node involvement is high.

The detailed delineation for CTV and OARs is shown in online supplemental file 1.

The margins between PTV and CTV depend on institutional standards of each study centre with 5 mm in minimum recommended excepted for regional nodes. For planning reasons, the PTV should be cropped 5 mm beneath the skin in case of BCS and 2 mm beneath the skin in case of mastectomy. In case of skin involvement, the ventral border expands to the skin surface.

OARs including ipsilateral and contralateral lung, heart, humeral head and spinal cord were contoured based on RTOG guidelines.

External beam equipment and techniques

The external beam RT are delivered with a linear accelerator with 6 MV of photon in most cases. Integrated multibeam IMRT will be generated and optimised using our predefined protocol for OARs constrains and target coverage.

Dose prescription, fractionation and bolus

Based on an α/β value of 3.5 Gy for breast cancer,⁹ 40 Gy in 15 fractions is applied to a hypofractionation group, which has been validated equivalent efficacy and safety to 50 Gy in 25 and recommended as the preferred regimen for WBI in international guidelines and clinical practice.⁹⁻¹² Thus, for all enrolled patients, the HF prescribed dose to ipsilateral chest wall or whole breast and regional lymph region is 4005 cGy in 15 fractions over 3 weeks. A sequential tumour bed boost is delivered at 1068 cGy in four fractions to patients treated with BCS. In the control group, the prescribed dose is 50 Gy in 25 fractions and sequential tumour bed boost of 10 Gy in five fractions is delivered with BCS.

Skin bolus of 3 mm on the whole chest wall is recommended to use in case of mastectomy and be documented as well as evaluated within the quality assurance-programmer of the study. If bolus is used, the skin dose

must accord with the dose-volume histogram (DVH) constraints of CTV and the volume of CTV should include the bolus.

DVH constraints

DVH constraints predefined for dose specification and dose reporting in PTV and OARs are detailed in tables 1 and 2. The goal of treatment planning is to provide best possible coverage of PTV and at the same time minimise the radiation dose-volume to OARs. The heart was contoured according to heart atlas published by Feng *et al*,³¹ which include the whole heart and major cardiac substructures (right atrium, left atrium, right ventricle, left ventricle, left main coronary artery and left anterior descending artery, left circumflex artery and right coronary artery). The DVH constraints was set for the whole heart, while the DVH data of cardiac substructures were collected for further exploratory analyses.

Treatment verification schedule and quality assurance

Daily patient set-up should be performed using laser alignment to skin markers. Online cone-beam CT verification with action level of correction being 5 mm, which must be taken during the first three treatment session and weekly thereafter. The delineations and the DVH constraints for CTV, PTV and OARs of the first 20 patients will be checked by a senior radiation oncologist in each participated centre. Acceptable deviations have been defined in the protocol and should be recorded.

Criteria for discontinuing interventions

Criteria for discontinuing intervention (exiting the trial) for a given trial participant are contemplated in the informed consent from (at patient's legal representative request). Enrolled patients can withdraw their informed consent and exit the trial at any time. If patients withdraw from the trial before RT, institutional standard fractionated RT will be applied. Adverse events should be

Table 1 DVH constraints for PTV

Structures	Constraints	Hypofractionated regimen	Conventional regimen
PTV of chest wall/breast+RNI	Per protocol	D95% >40 Gy	D95% >50 Gy
	Acceptable variation	D90% >40 Gy	D90% >50 Gy
	Per protocol	V43Gy <5%	V55Gy <5%
	Acceptable variation	V45Gy <5%	V56Gy <5%
	Per protocol	V38Gy >99%	V48Gy >99%
	Acceptable variation	V36Gy >99%	V45Gy >99%
PTV of breast+tumour bed boost+RNI	Per protocol	D95% >50 Gy	D95% >60 Gy
	Acceptable variation	D90% >50 Gy	D90% >60 Gy
	Per protocol	V55Gy <5%	V66Gy <5%
	Acceptable variation	V58Gy <5%	V69Gy <5%
	Per protocol	V48Gy >99%	V57Gy >99%
	Acceptable variation	V45Gy >99%	V54Gy >99%

DVH, dose-volume histogram; PTV, planning target volume; RNI, regional nodal irradiation.

Table 2 DVH constraints for OARs

OARs	Hypofractionated regimen			Conventional regimen		
	Dosimetric parameter	Per protocol	Acceptable variation	Dosimetric parameter	Per protocol	Acceptable variation
Heart for left-sided breast cancer	Mean	<5.5 Gy	<6.5 Gy	Mean	<7 Gy	<8 Gy
	V25Gy	<10%	<15%	V30Gy	<10%	<15%
	V8Gy	<20%	<25%	V10Gy	<20%	<25%
Heart for right-sided breast cancer	Mean	<2 Gy	<3 Gy	Mean	<2 Gy	<3 Gy
	V4Gy	<15%	<20%	V4Gy	<15%	<20%
Ipsilateral lung	Mean	<13 Gy	<14 Gy	Mean	<15 Gy	<16 Gy
	V8Gy	<45%	<55%	V10Gy	<45%	<55%
	V16Gy	<30%	<35%	V20Gy	<30%	<35%
	V25Gy	<23%	<25%	V30Gy	<23%	<25%
Contralateral lung	Mean	<2 Gy	<3 Gy	Mean	<2 Gy	<3 Gy
	V4Gy	<10%	<15%	V4Gy	<10%	<15%
Spinal cord	Max	<40 Gy	N/A	Max	<45 Gy	N/A
Ipsilateral humeral head	Mean	<20 Gy	<25 Gy	Mean	<20 Gy	<25 Gy

DVH, dose-volume histogram; OAR, organs at risk.

recorded in eCRF and reported to principal investigator (PI). Whether RT should be discontinued is at the discretion of individual investigator.

Endpoints

The primary endpoint of the trial is LRR, which is defined as any first recurrence confirmed by histology or cytology in the ipsilateral chest wall or breast or regional nodes areas (including axillary, supraclavicular, infraclavicular lymph nodes or IMNs).

Secondary endpoints are as following:

- ▶ **DMFS:** the time from the date of randomisation to any recurrence of tumour at distant sites or death from any cause.
- ▶ **IRFS:** the time from the date of randomisation to any invasive recurrence of tumour, distant metastases or death from any cause and second invasive primaries, including invasive neoplasms of the breast.
- ▶ **OS:** the time from the date of randomisation to the date of death from any cause or end of the follow-up.
- ▶ **Cosmetic outcomes:** patients receiving BCS are graded according to the BCS-Harvard/National Surgical Adjuvant Breast and Bowel Project /RTOG scoring scale grades: excellent, when compared with the untreated breast, there is a minimal or no difference in the size or shape of the treated breast; good, slight difference in the size or shape of the treated breast; fair, obvious difference in the size or shape of the treated breast; and poor, marked change in the size or shape of the treated breast.
- ▶ **Acute toxicities:** number of participants with \geq Grade 1 acute radiation-induced toxicities within time from beginning of RT to 6 months after completion of

RT assessed according to the Common Terminology Criteria for Adverse Events (CTCAE) V.3.0.

- ▶ **Late toxicities:** number of participants with \geq Grade 1 late radiation-induced toxicities within time from 6 months after completion of RT to 5 years after completion of RT assessed according to the RTOG/European Organization for Research on Treatment of Cancer (EORTC) Late Radiation Morbidity Scoring Schema and CTCAE V.3.0
- ▶ **Reconstruction complications:** number of participants with any reconstruction complications (flap necrosis, capsular contracture, infection, loss of implant/expander or flaps and so on) and the interval between the RT and reconstruction complications will be recorded. Patient reported outcome with reconstruction will be evaluated by Breast-Q questionnaires before RT and 12 months after RT.

Exploratory endpoints of the trial are quality of life using self-administered questionnaire EORTC QLQ-C30 and QLQ-BR23.

Outcome measures and follow-up

Schedule of enrollment, interventions and assessments are shown in [table 3](#). Any tumour recurrence, metastasis, death and radiation-related toxicity should also be recorded in the eCRF at each time of follow-up. Survival events will be assessed by physical examination, serum test, ultrasound of the breast, regional nodes and abdomen every 6 months, breast mammography and chest CT scan annually after completion of RT. Any additional examinations are at the discretion of clinicians. An increase in arm circumference of at least 10% in the lower arm or the upper arm, or both, compared with the contralateral

Table 3 Schedule of enrollment, interventions and assessments

Timepoint	Study period														
	Pre-radiotherapy				Interventions: radiotherapy				Post-radiotherapy						
	0	1w	2w	3w	4w	5w	6w	4w	6m	12m	18m	2y	3y	4y	5y
Enrollment															
Eligibility screening	X														
Informed consent	X														
Randomisation	X														
Interventions															
Hypofractionated regimen		X	X	X	X										
Conventional regimen		X	X	X	X	X	X								
Assessments															
Physical examination	X	X	X	X	X	X	X	X	X	X	X	X	X	X	X
Chest CT scan										X		X	X	X	X
Mammography										X		X	X	X	X
Ultrasound for breast and regional nodes	X								X	X	X	X	X	X	X
ECG	X								X	X	X	X	X	X	X
Echocardiography	X								X	X	X	X	X	X	X
Cosmetic outcomes for BCS	X							X	X	X	X	X	X	X	X
Quality of life	X							X	X	X	X	X	X	X	X
BCS, breast conserving surgery.															

arm at the same timepoint is recorded as clinically significant lymphoedema. Shoulder mobility, skin changes and overall change in breast appearance should be recorded using photos or videos. Quality of life data will be obtained using self-administered questionnaire EORTC QLQ-C30 and QLQ-BR23.

Data collection and management

Data of the trial will be collected and recorded in the eCRF established on the online clinical system build by Shanghai Jiao Tong University School of Medicine affiliated Ruijin Hospital. Participating centres have access to the online clinical system. The following forms have been created in the online system for the data collection: baseline information before randomisation, pretreatment assessment and RT plan details for HF or conventional group, acute toxicities reporting form during RT, follow-up review forms for different timepoints, quality of life questionnaire forms and serious adverse events (SAEs) reporting form. For patients who withdraws from the study, the effective date of notification is defined as the date when their withdrawal is received by the study team and information about these patients will not be collected afterwards.

The PIs, ethical committees, sponsors are allowed to access database for analysing and data monitoring at any time. Participating centres could have access to the data of their own centre. The leading investigators in each centre are responsible for monitoring the quality of data. Once the trial is completed, the data quality and integrity will be checked by specific trained staffs and then closed for analysis.

All data generated in this study will remain confidential. Any public reports of this study will not disclose the personal identity of the patients. The research centre will keep all relevant data of this study for at least 5 years after the completion of study and permission of the ethical committee is need for destruction of data.

Calculation of samples

The sample size is calculated with Power Analysis and Sample Size Software (2017) (NCSS, Kaysville, Utah, USA, www.ncss.com/software/pass) with sample allocation ratio of 1:1 between HF-RT regimen and conventional regimen. The primary objective is to compare the cumulative incidence of patients experiencing an LRR by 5 years between HF-RT and conventional course of RT. Based on the outcomes of patients treated at our institute, the cumulative proportion of the LRR in the control arm is expected to be 8% at 5 years. We accepted a maximum loss of efficacy of 6% points in the HF radiation group (corresponding to an HR of 1.81). This non-inferiority margin was determined through consultation with radiation oncologists. The sample size for the trial, a total of 801 patients, was based on these assumptions and a power of 80% with a one-sided type I error of 2.5%, and the anticipated drop-out rate of 10%. Patients will be

recruited over a period of 3 years and followed up for a further 5 years thereafter.

Statistical analysis

For the primary endpoint, Kaplan-Meier curves of 5-year LRR incidence rates will be reported. Cumulative incidence of LRR will also be estimated using the competing risk model, with death as a competing event, and compared by Gray's test. The HR and the 95% CIs for LRR will be computed using the Cox proportional hazards regression. Primary assessment of non-inferiority is based on whether the upper limit of the two-sided 95% CI (corresponding to one-sided 97.5% CI) for the absolute difference in 5-year LRR was less than 6%. Non-inferiority of HF versus conventional group will also be tested using the a priori critical HR of 1.81 ($\ln 0.86 / \ln 0.92$, from protocol-specified incidence) with estimated accrual of 3years. Cumulative proportions of time to survival endpoints like DMFS, IRFS, OS will be computed using Kaplan-Meier method, and compared between groups by the log-rank test. Acute and late toxicities were summarised as frequency and severity on the basis of their association with protocol treatment. Categorical variables including acute or late toxicities and cosmetic outcomes for BCS will be compared using χ^2 test or Wilcoxon test while multivariate logistic regression will be performed to explore influencing factors. Severe radiation-related toxicity events will be listed one by one. The t-test was used for comparison of the continuous variables. Subgroup analysis for LRR according to number of positive lymph nodes and type of breast surgery will be also computed. Last observation carried forward will be performed for missing data. All tests will be two-sided with a significance level of 0.05 except the primary endpoint. All efficacy and safety analyses are based on the intention-to-treat principle, and per-protocol analysis will be performed for the primary endpoint. Statistical analysis will be performed with SPSS software V.21.0 (IBM Corporation, Armonk, New York, USA).

Monitoring

All leading investigators of the participating centres are members of the trial steering committee (TSC). Study coordination, monitoring, data acquisition, management and statistical analysis will be performed by the statisticians in Ruijin Hospital affiliated to Shanghai Jiao Tong University School of Medicine. An independent data safety and monitoring committee is constituted for monitoring the trial progress, safety data, data quality and making recommendations to the TSC about the continuation of the trial based on the available data provided by investigators.

The adverse event is defined as any untoward medical occur to the patient during the trial, which do not necessarily have a causal relationship with RT. All SAEs should be reported to the ethical committee within 24 hours after being received by the PI. Once a patient has an SAE, all anti-tumour treatments should be stopped immediately.

All adverse events should be followed until resolution or until the event is considered stable, including adverse events that induce patient's withdrawal from the study. The time, severity, expectedness, duration, measures taken and outcome of SAEs should be recorded in the eCRF. General adverse events are required to be reported to the ethical committee and the PI regularly, once every 6–12 months.

Ethics and dissemination

The study has been approved by the Ethical Committee of Ruijin Hospital affiliated to Shanghai Jiao Tong University School of Medicine (version 2018-95-3) and approvals from ethical committee of each participating centre have also been obtained. Any modifications to the protocol will be documented in the protocol amendments, which should be approved by the ethical committee prior to implementation. This study is conducted in accordance with the Declaration of Helsinki and good clinical practice. Written informed consent is obtained from all participants before enrollment.

Research findings will be submitted for publication in peer-reviewed journals. Authors will be individuals who have made key contributions to study design and conduct. The clinical study reports and summary thereof will be provided to the local ethical committee of the institutes and sponsors participating in the protocol.

Patient and public involvement

Patients or members of the public were not involved in the design, or conduct, or reporting, or dissemination plans of our research.

DISCUSSION

This is an open-label, randomised, non-inferior, multi-centre phase III trial. Our primary objective is to investigate whether the efficacy and safety of 3-week HF-RT regimen is non-inferior to 5-week conventional regimen in patients receiving comprehensive RNI not limited to supra/infraclavicular nodes and IMNs, but also axillary nodes when indicated such as patients receiving sentinel lymph nodes biopsy (SLNB) with positive pathological nodes without undergoing subsequent axillary dissection while the risk of non-sentinel axillary nodes involvement is high. In this trial, all the comprehensive nodal regions are treated with the ipsilateral breast/chest-wall as an integrated planning target with inverse planning IMRT. These are two key features in the design of this trial compared with other ongoing and published trials of HF-RNI.

The role of IMN irradiation has been well established in clinical randomised trials and series of meta-analyses published by EBCTCG.^{2–4} In MA20 trial, RNI was found to significantly increase the rate of disease-free survival (DFS) from 77% to 82% (HR, 0.76; 95% CI, 0.61 to 0.94; *p* value=0.01) at 10 years follow-up in BCS patients with node-positive or high-risk node-negative breast cancer.³

EORTC 22922/10925 trial also reported that RNI was associated with significant improvements in DFS (72.1% vs 69.1%; HR, 0.89; 95% CI, 0.80 to 1.00; *p*=0.04) and DMFS (78.0% vs 75.0%; HR, 0.86; 95% CI, 0.76 to 0.98; *p*=0.02) and reduction in breast-cancer mortality (12.5% vs 14.4%; HR, 0.82; 95% CI, 0.70 to 0.97; *p*=0.02) with a median follow-up of 10.9 years in patients with positive axillary nodes or a centrally or medially located primary tumour.² Both of these two trials included the IMN in the fields of RNI. Danish breast cancer cooperation group IMN study demonstrated that addition of IMN irradiation to RNI significantly improved OS and breast cancer-specific survival in node positive patients after a median follow-up of 8.9 years.⁴ In the EBCTCG meta-analysis, post mastectomy RT (PMRT) was found to significantly reduce LRR, any recurrence and breast cancer mortality. In 20 out of 22 trials enrolled in this meta-analysis, RT was given to the IMN.⁵ Based on these evidences, the latest version of NCCN Guidelines (V.3.2020) recommends delivery of IMN irradiation in patients with ≥ 4 positive axillary lymph nodes (ALNs) (category 1) and in those with 1–3 positive ALNs (category 2A).³²

Nevertheless, the inclusion of RNI does increase the complexity of treatment planning, potentially increase the risk of dose-volume to the heart and lung.³³ Thus, IMN was not mandatory in irradiation fields of RNI in the published randomised trial and in majority of ongoing trials of HF-RNI (shown in table 4). With the maturity of IMRT and increasing awareness of OAR sparing in RNI, it is now possible to minimise the increase of normal tissue irradiated volume associated with IMN irradiation. In the recent EBCTCG meta-analysis of RNI, 12 out of 14 enrolled trials had IMN irradiation.²⁷ The results showed that RNI in 'newer trials' since 1989 significantly reduced breast cancer mortality (risk ratio=0.82, *p* value=0.00006) and had no significant impact on non-breast cancer mortality (risk ratio=0.96, *p* value=0.66), while non-breast cancer mortality was significantly increased in 'older trials'. These data prove that the therapeutic benefit of comprehensive nodal irradiation in high-risk patients is significantly displayed when OAR dose-volume is well controlled.

Another characteristic of this trial is that it enrolls patients undergoing SLNB with positive pathological nodes without subsequent axillary dissection, and the RNI field is allowed to include the axilla as long as the treatment planning meets the target and OAR DVH constraints. In Z0011 trial, SLNB had been proved as safe as axillary lymph node dissection (ALND) for patients with 1 to 2 SLNs.³⁴ The EORTC 10981/22023 trial demonstrated that axillary RT and ALND after a positive sentinel node provide excellent and comparable axillary control for patients with T1–2 primary breast cancer,³⁵ while axillary RT was associated with significantly less lymphoedema events during the long-term follow-up.^{35 36} In a recent prospective screening trial, 1815 patients were enrolled to explore the impact of axillary surgery type and regional lymph node radiation on lymphoedema.³⁷ The

Table 4 The ongoing trials on HF-RNI in breast cancer

NCT number	Country	Start year	Randomised	Enrolled patients	Reconstruction	IMN	Study group	Control group	No	Endpoint	Status
NCT03319069	Egypt	2017	Yes	T3–4 or ≥N2	No	No	43.5Gy/15Fx/3w	50Gy/25Fx/3w	60	Locoregional control	Unknown
NCT02958774	America	2017	No	Stage II–III with N+ or T3N0	Not mentioned	Not mentioned	40.05Gy/15Fx/3w	N/A	389	Lymphoedema rates	Recruiting
NCT03127995	France	Not yet	Yes	pT1–3N0–3M0	Not mentioned	Not mentioned	40Gy/15Fx/5w	50Gy/25Fx/5w	1265	Arm lymphoedema	Not yet recruiting
NCT03856372	China	2018	Yes	T1–2N1 with high risk factor* or T3–4, or N2–3	Yes	Not mentioned	42.56Gy/16Fx/3w	50Gy/25Fx/5w	1494	Locoregional control	Recruiting
NCT02690636	Egypt	2016	Yes	pT1–3, N1–2	Not mentioned	Not mentioned	42.56Gy/16Fx/3w	50Gy/25Fx/5w	500	Locoregional control	Recruiting
NCT02912312†	America	2017	Yes	T0–T3, N0–N2a or N3a	Not mentioned	Not mentioned	15Fx in 3w	25Fx in 5w	290	Lymphoedema rates	Recruiting
NCT02700386	America	Not yet	No	Stage IB–IIIB	Yes	Not mentioned	40.05Gy/15Fx/3w	N/A	112	Treatment-related adverse events	Not yet recruiting
NCT02515110	America	2015	No	T1–3, N1–2a	Yes	Not mentioned	42.56Gy/16Fx/3w	N/A	137	Lymphoedema rates	Recruiting
NCT04228991	Canada	2021	Yes	T1–3, N1–2	No	Yes	26Gy/5Fx/1w	40Gy/15Fx/3w	588	Lymphoedema rates	Recruiting
NCT03414970	America	2018	Yes	Stage Ila–IIla	Yes	Yes	15Fx in 3w	25Fx in 5w	880	Reconstruction complication rate	Recruiting
NCT04472845	India	2020	Yes	pT3–4pN2–3 M0	No	Partly‡	26Gy/5Fx/1w	40Gy/15Fx/3w	1018	Locoregional control	Not yet recruiting
NCT04509648	China	2021	No	pT1–3N1–3	Yes	Yes	26Gy/5Fx/1w	N/A	197	Acute radiation-induced toxicity	Recruiting

*At least one of the following risk factors: <40 years, Grade 3, lymphovascular invasion positive, ER/PR negative or HER-2 overexpression.

†The trial included preoperative radiation therapy.

‡In T3–4 central and inner quadrant lesions and patients with N2 disease. ER, estrogen receptor; Fx, fractions; HER-2, human epidermal growth factor receptor-2; HF-RNI, hypofractionated regional nodal irradiation; N/A, not applicable; PR, progesterone receptor; w, weeks.



results showed that ALND-alone group had a significantly higher lymphoedema risk compared with the axillary RT following SLNB (HR=2.66, $p=0.02$). These prospective trials have provided evidences that omitting the ALND for patients with limited positive sentinel lymph nodes is safe and will result in less lymphoedema. There is lack of literature to support the use of axillary RT with HF. Therefore, our trial enrolls patients undergoing SLNB with positive pathological nodes without subsequent axillary dissection.

The negative influence of PMRT on cosmetic outcome in patients receiving immediate breast reconstruction (IBR), especially implant-based IBR has been widely reported.^{38–41} Efforts including more sophisticated delineation of CTV based on different T stage, implant-pectoris muscle special relationship and improved dose homogeneity are being made to ameliorate the detrimental effect of ionising irradiation to cosmesis.^{42–45} Some retrospective studies and subgroup analysis of a prospective phase II study have indicated that the feasibility of adjuvant HF among breast cancer treated with IBR.^{26 46 47} Thus, patients with breast cancer receiving IBR would be enrolled in the present study.

In our previous study, treating chest wall/whole breast and at-risk nodal volume including IMN as a whole PTV using IMRT technique has been proved to achieve good PTV coverage, satisfactory dose coverage and homogeneity of PTV and irradiation dose of OARs.^{48 49} Based on the strict DVH constraints and maturation of IMRT technique, we include the IMN in the fields of RNI by using IMRT technique in this trial, in order to investigate the efficacy toxicity of HF-RNI.

We hope that our trial could provide high-level evidence to support 3-week regimen of RNI as standard option in patients with breast cancer with an indication for RNI following BCS or mastectomy. And we also aim to clearly define the safety of IMN irradiation using modern IMRT technique.

Author affiliations

¹Department of Radiation Oncology, Shanghai Jiao Tong University Medical School Affiliated Ruijin Hospital, Shanghai, Shanghai, China

²Department of Radiation Oncology, Affiliated Hospital of Jiangnan University, Wuxi, Jiangsu, China

³Yat-Sen Breast Tumor Hospital, Sun Yat-Sen Memorial Hospital, Sun Yat-Sen University, Guangzhou, Guangdong, China

⁴Guangdong Provincial Key Laboratory of Malignant Tumor Epigenetics and Gene Regulation, Medical Research Centre, Sun Yat-Sen Memorial Hospital, Sun Yat-Sen University, Guangzhou, Guangdong, China

⁵Department of Radiation Oncology, Affiliated Tumor Hospital of Nantong University, Nantong, Jiangsu, China

⁶Department of Radiation Oncology, Shanghai Tenth People's Hospital, Shanghai, Shanghai, China

⁷Department of Radiation Oncology, Shanghai Jiao Tong University School of Medicine Affiliated Ninth People's Hospital, Shanghai, Shanghai, China

⁸Clinical Research Centre, Ruijin Hospital, Shanghai Jiaotong University School of Medicine, Shanghai, Shanghai, China

⁹Department of General Surgery, Comprehensive Breast Health Centre, Ruijin Hospital, Shanghai Jiao Tong University School of Medicine, Shanghai, Shanghai, China

¹⁰Department of Radiation Oncology, Sun Yat-Sen Memorial Hospital, Sun Yat-Sen University, Guangzhou, Guangdong, China

Acknowledgements We thank all the patients who participated in this study, and the oncologists, nurses, medical physicists, RT technicians and data managers at the participating centers.

Contributors W-XQ, LC and JC designed the original protocol for the study. FX contributed to study management. JX, FX, W-XQ, LC and XT drafted the manuscript. JX submitted the study. W-XQ and JL performed the sample size calculation and data analysis. JX, FX, YZ, GC, XL, QZ, QL, YY, CX, RC, SW, XT, CC, SZ, MeC, MiC, XQ, CS, JL, HX, FX, YH, ML, DO, KWS, W-XQ, LC, XH, JC participated in enrollment, treatment and follow-up of patients.

Funding This study was supported in part by the Clinical Research Plan of SHDC (grant numbers SHDC2020CR2052B), National Key Research and Development Program of China (grant numbers 2016YFC0105409), Scientific and Technological Innovation Action Plan of Shanghai Science and Technology Committee (grant numbers 19411950900, 19411950901).

Competing interests None declared.

Patient and public involvement Patients and/or the public were not involved in the design, or conduct, or reporting, or dissemination plans of this research.

Patient consent for publication Consent obtained directly from patient(s)

Provenance and peer review Not commissioned; externally peer reviewed.

Supplemental material This content has been supplied by the author(s). It has not been vetted by BMJ Publishing Group Limited (BMJ) and may not have been peer-reviewed. Any opinions or recommendations discussed are solely those of the author(s) and are not endorsed by BMJ. BMJ disclaims all liability and responsibility arising from any reliance placed on the content. Where the content includes any translated material, BMJ does not warrant the accuracy and reliability of the translations (including but not limited to local regulations, clinical guidelines, terminology, drug names and drug dosages), and is not responsible for any error and/or omissions arising from translation and adaptation or otherwise.

Open access This is an open access article distributed in accordance with the Creative Commons Attribution Non Commercial (CC BY-NC 4.0) license, which permits others to distribute, remix, adapt, build upon this work non-commercially, and license their derivative works on different terms, provided the original work is properly cited, appropriate credit is given, any changes made indicated, and the use is non-commercial. See: <http://creativecommons.org/licenses/by-nc/4.0/>.

ORCID iD

Jinrong Xie <http://orcid.org/0000-0002-4025-7367>

REFERENCES

- 1 Bray F, Ferlay J, Soerjomataram I, *et al*. Global cancer statistics 2018: GLOBOCAN estimates of incidence and mortality worldwide for 36 cancers in 185 countries. *CA Cancer J Clin* 2018;68:394–424.
- 2 Poortmans PM, Collette S, Kirkove C, *et al*. Internal mammary and medial supraclavicular irradiation in breast cancer. *N Engl J Med* 2015;373:317–27.
- 3 Whelan TJ, Olivetto IA, Parulekar WR, *et al*. Regional nodal irradiation in early-stage breast cancer. *N Engl J Med* 2015;373:307–16.
- 4 Thorsen LBJ, Offersen BV, Danø H, *et al*. DBCG-IMN: a population-based cohort study on the effect of internal mammary node irradiation in early node-positive breast cancer. *J Clin Oncol* 2016;34:314–20.
- 5 McGale P, Taylor C, EBCTCG (Early Breast Cancer Trialists' Collaborative Group). Effect of radiotherapy after mastectomy and axillary surgery on 10-year recurrence and 20-year breast cancer mortality: meta-analysis of individual patient data for 8135 women in 22 randomised trials 2014;383:2127–35.
- 6 Darby S, McGale P, Early Breast Cancer Trialists' Collaborative Group (EBCTCG). Effect of radiotherapy after breast-conserving surgery on 10-year recurrence and 15-year breast cancer death: meta-analysis of individual patient data for 10,801 women in 17 randomised trials 2011;378:22019144–16.
- 7 Early Breast Cancer Trialists' Collaborative Group (EBCTCG). Effects of chemotherapy and hormonal therapy for early breast cancer on recurrence and 15-year survival: an overview of the randomised trials. *Lancet* 2005;365:1687–717.
- 8 Yarnold J, Ashton A, Bliss J, *et al*. Fractionation sensitivity and dose response of late adverse effects in the breast after radiotherapy

- for early breast cancer: long-term results of a randomised trial. *Radiother Oncol* 2005;75:9–17.
- 9 Haviland JS, Owen JR, Dewar JA, *et al*. The UK standardisation of breast radiotherapy (start) trials of radiotherapy hypofractionation for treatment of early breast cancer: 10-year follow-up results of two randomised controlled trials. *Lancet Oncol* 2013;14:1086–94.
 - 10 , Bentzen SM, Agrawal RK, group TFT, *et al*, START Trialists' Group. The UK standardisation of breast radiotherapy (start) trial of radiotherapy hypofractionation for treatment of early breast cancer: a randomised trial. *Lancet Oncol* 2008;9:331–41.
 - 11 group TFT. The UK standardisation of breast radiotherapy (start) trial B of radiotherapy hypofractionation for treatment of early breast cancer: a randomised trial. *The Lancet* 2008;371:1098–107.
 - 12 Whelan TJ, Pignol J-P, Levine MN, *et al*. Long-Term results of hypofractionated radiation therapy for breast cancer. *N Engl J Med* 2010;362:513–20.
 - 13 Wang S-L, Fang H, Hu C, *et al*. Hypofractionated versus conventional fractionated radiotherapy after breast-conserving surgery in the modern treatment era: a multicenter, randomized controlled trial from China. *J Clin Oncol* 2020;38:3604–14.
 - 14 Valle LF, Agarwal S, Bickel KE, *et al*. Hypofractionated whole breast radiotherapy in breast conservation for early-stage breast cancer: a systematic review and meta-analysis of randomized trials. *Breast Cancer Res Treat* 2017;162:409–17.
 - 15 Gradishar WJ, Anderson BO, Balassanian R, *et al*. Breast cancer version 2.2015. *J Natl Compr Canc Netw* 2015;13:448–75.
 - 16 Smith BD, Bellon JR, Blitzblau R, *et al*. Radiation therapy for the whole breast: Executive summary of an American Society for radiation oncology (ASTRO) evidence-based guideline. *Pract Radiat Oncol* 2018;8:145–52.
 - 17 Cardoso F, Kyriakides S, Ohno S, *et al*. Early breast cancer: ESMO clinical practice guidelines for diagnosis, treatment and follow-up. *Ann Oncol* 2019;30:1194–220.
 - 18 Murray Brunt A, Haviland JS, Wheatley DA, *et al*. Hypofractionated breast radiotherapy for 1 week versus 3 weeks (FAST-Forward): 5-year efficacy and late normal tissue effects results from a multicentre, non-inferiority, randomised, phase 3 trial. *Lancet* 2020;395:1613–26.
 - 19 Batumalai V, Delaney GP, Descallar J, *et al*. Variation in the use of radiotherapy fractionation for breast cancer: survival outcome and cost implications. *Radiother Oncol* 2020;152:70–7.
 - 20 Bekelman JE, Sylwestrzak G, Barron J, *et al*. Uptake and costs of hypofractionated vs conventional whole breast irradiation after breast conserving surgery in the United States, 2008–2013. *JAMA* 2014;312:2542–50.
 - 21 Khan AJ, Rafique R, Zafar W, *et al*. Nation-Scale adoption of shorter breast radiation therapy schedules can increase survival in resource constrained economies: results from a Markov chain analysis. *Int J Radiat Oncol Biol Phys* 2017;97:287–95.
 - 22 Deshmukh AA, Shirvani SM, Lal L, *et al*. Cost-Effectiveness analysis comparing conventional, Hypofractionated, and intraoperative radiotherapy for early-stage breast cancer. *J Natl Cancer Inst* 2017;109. doi:10.1093/jnci/djx068. [Epub ahead of print: 01 11 2017].
 - 23 Yadav BS, Sharma SC. A Phase 2 Study of 2 Weeks of Adjuvant Whole Breast/Chest Wall and/or Regional Nodal Radiation Therapy for Patients With Breast Cancer. *Int J Radiat Oncol Biol Phys* 2018;100:874–81.
 - 24 Wang S-L, Fang H, Song Y-W. Hypofractionated versus conventional fractionated postmastectomy radiotherapy for patients with high-risk breast cancer: a randomised, non-inferiority, open-label, phase 3 trial. *Lancet Oncol* 2019;20:352–60.
 - 25 Poppe MM, Yehia ZA, Baker C, *et al*. 5-Year update of a Multi-Institution, prospective phase 2 Hypofractionated postmastectomy radiation therapy trial. *Int J Radiat Oncol Biol Phys* 2020;107:694–700.
 - 26 Khan AJ, Poppe MM, Goyal S, *et al*. Hypofractionated postmastectomy radiation therapy is safe and effective: first results from a prospective phase II trial. *J Clin Oncol* 2017;35:2037–43.
 - 27 Dodwell CT D, McGale P, Coles C. Regional lymph node irradiation in early stage breast cancer: an EBCTCG meta-analysis of 13,000 women in 14 trials. In: *San Antonio Breast Cancer Symposium ; December 4-8, 2018*. San Antonio, Texas: American Association for Cancer Research, 2020: GS4–02.
 - 28 Ma J, Li J, Xie J, *et al*. Post mastectomy linac IMRT irradiation of chest wall and regional nodes: dosimetry data and acute toxicities. *Radiat Oncol* 2013;8:81.
 - 29 Cao L, Cai G, Chang C, *et al*. Diastolic dysfunction occurs early in HER2-positive breast cancer patients treated concurrently with radiation therapy and trastuzumab. *Oncologist* 2015;20:605–14.
 - 30 Group. RTO. Breast cancer atlas for radiation therapy planning: consensus definitions. 2013.
 - 31 Feng M, Moran JM, Koelling T, *et al*. Development and validation of a heart atlas to study cardiac exposure to radiation following treatment for breast cancer. *Int J Radiat Oncol Biol Phys* 2011;79:10–18.
 - 32 Gradishar WJ, Anderson BO, Abraham J, *et al*. Breast cancer, version 3.2020, NCCN clinical practice guidelines in oncology. *J Natl Compr Canc Netw* 2020;18:452–78.
 - 33 Haffty BG, Whelan T, Poortmans PM. Radiation of the internal mammary nodes: is there a benefit? *JCO* 2016;34:297–9.
 - 34 Giuliano AE *et al*. Axillary dissection vs no axillary dissection in women with invasive breast cancer and sentinel node metastasis. *JAMA* 2011;305:569–75.
 - 35 Donker M, van Tienhoven G, Straver ME, *et al*. Radiotherapy or surgery of the axilla after a positive sentinel node in breast cancer (EORTC 10981-22023 AMAROS): a randomised, multicentre, open-label, phase 3 non-inferiority trial. *Lancet Oncol* 2014;15:1303–10.
 - 36 Rutgers MD EJ, Poncet C, Straver ME, *et al*. Abstract GS4-01: radiotherapy or surgery of the axilla after a positive sentinel node in breast cancer patients: 10 year follow up results of the EORTC AMAROS trial (EORTC 10981/22023). *San Antonio Breast Cancer Symposium; December 6; San Antonio, TX 2018*.
 - 37 Naoum GE, Roberts S, Brunelle CL, *et al*. Quantifying the impact of axillary surgery and nodal irradiation on breast Cancer-Related lymphedema and local tumor control: long-term results from a prospective screening trial. *Journal of Clinical Oncology* 2020;38:3430–8.
 - 38 AY H, ZI H, Mehrara BJ, *et al*. Radiotherapy in the setting of breast reconstruction: types, techniques, and timing. *The Lancet Oncology* 2017;18:e742–53.
 - 39 Whitfield GA, Horan G, Irwin MS, *et al*. Incidence of severe capsular contracture following implant-based immediate breast reconstruction with or without postoperative chest wall radiotherapy using 40 gray in 15 fractions. *Radiotherapy and Oncology* 2009;90:141–7.
 - 40 Headon H, Kasem A, Mokbel K. Capsular contracture after breast augmentation: an update for clinical practice. *Arch Plast Surg* 2015;42:532–43.
 - 41 Magill LJ, Robertson FP, Jell G, *et al*. Determining the outcomes of post-mastectomy radiation therapy delivered to the definitive implant in patients undergoing one- and two-stage implant-based breast reconstruction: A systematic review and meta-analysis. *Journal of Plastic, Reconstructive & Aesthetic Surgery* 2017;70:1329–35.
 - 42 Leonardi MC, Spoto R, Miglietta E, *et al*. HALFMOON tomotherapy (helical altered fractionation for iMplant partial omission): iMplant-sparing post-mastectomy radiotherapy reshaping the clinical target volume in the reconstructed breast. *J Cancer Res Clin Oncol* 2019;145:1887–96.
 - 43 Nissen HD, Yates ES, Andersen K, *et al*. PO-0918: consensus on target volume delineation and treatment planning strategy for the DBCG RT RECON trial. *Radiotherapy and Oncology* 2018;127:S492–4.
 - 44 Kaidar-Person O, Vrou Offersen B, Hol S, *et al*. ESTRO ACROP consensus guideline for target volume delineation in the setting of postmastectomy radiation therapy after implant-based immediate reconstruction for early stage breast cancer. *Radiotherapy and Oncology* 2019;137:159–66.
 - 45 Kaidar-Person O, Nissen HD, Yates ES, *et al*. Postmastectomy radiation therapy planning after immediate implant-based reconstruction using the European Society for radiotherapy and Oncology-Advisory Committee in radiation oncology practice consensus guidelines for target volume delineation. *Clin Oncol* 2021;33:20–9.
 - 46 Kim D-Y, Park E, Heo CY, *et al*. Hypofractionated versus conventional fractionated radiotherapy for breast cancer in patients with reconstructed breast: toxicity analysis. *The Breast* 2021;55:37–44.
 - 47 Song SY, Chang JS, Fan KL, *et al*. Hypofractionated radiotherapy with volumetric modulated Arc therapy decreases postoperative complications in prosthetic breast reconstructions: a clinicopathologic study. *Front Oncol* 2020;10:577136.
 - 48 Ma J, Li J, Xie J, *et al*. Post mastectomy linac IMRT irradiation of chest wall and regional nodes: dosimetry data and acute toxicities. *Radiation Oncology* 2013;8:81.
 - 49 Wu H, Cao L, Cai G, *et al*. Dosimetric study of cardioumonary volume dose of internal mammary node irradiation under inverse-planned intensity-modulated radiation therapy. *Chin J Radial Oncol* 2020;29:1048–53.