



Research article

Improved accuracy in IoT-Based water quality monitoring for aquaculture tanks using low-cost sensors: Asian seabass fish farming

Nurshahida Azreen Mohd Jais^{a,*}, Ahmad Fikri Abdullah^{a,b},
Muhamad Saufi Mohd Kassim^b, Murni Marlina Abd Karim^a, Abdulsalam M^a,
Nur 'Atirah Muhadi^b

^a International Institute of Aquaculture and Aquatic Sciences (I-AQUAS), Universiti Putra Malaysia, Lot 960 Jln Kemang 6, 71050, Port Dickson, Negeri Sembilan, Malaysia

^b Department of Biological and Agricultural Engineering, Faculty of Engineering, Universiti Putra Malaysia, 43400, UPM Serdang, Selangor, Malaysia

ARTICLE INFO

Keywords:

IoT
Water quality monitoring
Low-cost sensor
Aquaculture tank
Simple linear regression
Self-designed casing sensor

ABSTRACT

Traditional approaches to monitoring water quality in aquaculture tanks present numerous limitations, including the inability to provide real-time data, which can lead to improper feeding practices, reduced productivity, and potential environmental risks. To address these challenges, this study aimed to create an accurate water quality monitoring system for Asian seabass fish farming in aquaculture tanks. This was achieved by enhancing the accuracy of low-cost sensors using simple linear regression and validating the IoT system data with YSI Professional Pro. The system's development and validation were conducted over three months, employing professional devices for accuracy assessment. The accuracy of low-cost sensors was significantly improved through simple linear regression. The results demonstrated impressive accuracy levels ranging from 76% to 97%. The relative error values which range from 0.27% to 4% demonstrate a smaller range compared to the values obtained from the YSI probe during the validation process, signifying the enhanced accuracy and reliability of the IoT sensor by using simple linear regression. The system's enhanced accuracy facilitates convenient and reliable real-time water quality monitoring for aquafarmers. Real-time data visualization was achieved through a microcontroller, Thingspeak, Virtuino application, and ESP 8266 Wi-Fi module, providing comprehensive insights into water quality conditions. Overall, this adaptable tool holds promise for accurate water quality management in diverse aquatic farming practices, ultimately leading to improved yields and sustainability.

1. Introduction

Asian sea bass, also known as the barramundi or giant perch, is a popular food fish in many countries in Southeast Asia, including Malaysia [1]. It is a species of perciform fish that is native to the rivers and estuaries of Southeast Asia, but it is also farmed in many

* Corresponding author.

E-mail addresses: gs64042@student.upm.edu.my (N.A. Mohd Jais), ahmadfikri@upm.edu.my (A.F. Abdullah), saufi@upm.edu.my (M.S. Mohd Kassim), murnimarlina@upm.edu.my (M.M. Abd Karim), abdulsalam@upm.edu.my (A. M), nuratirah@upm.edu.my (N.' Muhadi).

<https://doi.org/10.1016/j.heliyon.2024.e29022>

Received 6 August 2023; Received in revised form 3 March 2024; Accepted 28 March 2024

Available online 3 April 2024

2405-8440/© 2024 Universiti Putra Malaysia. Published by Elsevier Ltd. This is an open access article under the CC BY-NC-ND license (<http://creativecommons.org/licenses/by-nc-nd/4.0/>).

parts of the world for its flavorful white flesh [2]. Furthermore, they are rapid growth, and capable of adapting to the environment easily either in the tank or in the cage culture. Despite these desirable qualities, a dramatic decline in the production of this species started in 2019. A report has shown that an over 50% reduction in the total annual was noticed in Malaysia in 2019 [3]. It was affirmed that the inconsistency in the water quality and the unrefined traditional management technique in aquaculture tanks is the main cause of the significant decline in the yield. The continued accumulation of the remnants of contaminants after every treatment using the traditional method exposes the fish to diseases, stunted growth, as well a high mortality rate.

The conventional method for monitoring water quality in aquaculture tanks is labor-intensive and costly. It involves farmers manually collecting water samples from tanks twice a day, which are then tested in laboratories using methods such as test kits to measure parameters like ammonia and pH levels. Unfortunately, this approach does not offer real-time data for aquaculture farming [4]. Recently, technology such as the Internet of Things (IoT) has been a timely and interactive way to solve these problems and ensures an increase higher productivity. This technology consistently monitors water quality parameters with an advanced communication module, thus reducing losses, mitigating disease outbreaks, and preventing the risk of eutrophication.

Several studies have used low-cost sensors for IoT-based water quality monitoring systems (WQMS) in aquaculture tanks. Palconit et al. [5] developed a fish tank monitoring system by using the Internet of Things (IoT) based on five crucial parameters sensors, Arduino uno as a controller board, and an affordable communication module such as ESP 8266. The evaluation of this system has included a few analyses for data collection such as the calibration of sensors and comparing two data transmissions for IoT modules. Chen et al. [6] used the Lora network to transmit temperature, pH, dissolved oxygen, water level, and life expectancy of the sensor in four fish ponds to the cloud. This system incorporates robotic arms equipped with programmable logic controllers for automated pH measurements. This is crucial as the pH sensor cannot remain submerged in the liquid for extended periods. Furthermore, the system includes an assessment of data transmission capabilities utilizing various LPWAN. While the previous studies mentioned employed low-cost sensors for their IoT-WQMS in aquaculture tanks and included system evaluation, they lacked a significant emphasis on the evaluation of the sensors themselves, especially in comparison with other reliable references or professional devices [7]. Additionally, most of these studies conducted testing for relatively short durations, typically measuring parameters continuously every second within a single day [7].

A variety types of commercial low-cost sensors have been used in the IoT-based WQMS aquaculture tank such as DFRobot, Atlas Scientific, and Vernier. Each of these brands has its own calibration procedure to improve the reliability of low-cost sensors. Some IoT-WQMS have proposed the calibration for their low-cost sensors in the system. Borquez Lopez et al. [8] developed an IoT-based WQMS for measuring temperature, pH, and dissolved oxygen in fish tanks by using wireless Zigbee. Three crucial parameters in this system were calibrated before testing the sensor data such as pH using three points buffer (4.0, 7.0, and 10.0) and DO using a reference solution using 0 mg/L to ensure the precise measurements. Another IoT-based WQMS in an aquaculture tank using low-cost sensors was presented by Parra et al. [9]. They employed various sensors for monitoring water quality parameters, fish feeding behavior, and tank condition with complete three nodes using Access Point (AP) to transmit data to the server. Moreover, calibration for sensors was applied in this system as recommended by the manufacturer to ensure its suitability. Fu et al. [10] proposed an intelligent fish tank system that employed a Wi-Fi communication module to measure multiple parameters and sensors were calibrated to ensure the accuracy of data results. While calibration is a crucial step, it may not be sufficient to guarantee the system's accuracy. To enhance precision in data results, it is imperative to incorporate algorithms into the system. These algorithms can play a crucial role in improving the accuracy of the collected data [11].

Furthermore, it is essential to consider that distinct sensors come with specific conditions. For example, certain probes or sensors are tailored for use exclusively in either seawater or freshwater, and some sensors may require limited immersion to maintain their accuracy and durability [6]. Nonetheless, many of these studies do not adequately address the crucial issues related to the longevity and accuracy in management of low-cost sensors. Therefore, the implementation of a robust IoT-based water quality monitoring system (WQMS) in real-time using the appropriate sensors with the improvement of sensor's accuracy is needed for optimizing productivity and effective management in Asian Seabass fish farming in tanks.

Based on findings from the review of literature [8–11], this study addresses gaps in existing water quality monitoring systems by developing an improved accuracy in IoT-based Water Quality Monitoring System (WQMS) for Asian seabass fish farming. The system utilizes affordable sensors, validated with professional devices over three months. It aims to enhance sensor accuracy through the integration of simple linear regression in the IoT coding system and maintain the sensor lifespan for improved real-time monitoring. The proposed system contains three main parts which are the IoT-based WQMS architecture, improvement of sensor accuracy, and development of casing sensors for aquaculture tanks. The IoT-based WQMS architecture involves the development of a monitoring system using low-cost sensors and an ESP 8266 communication module. This section covers monitoring, time management, communication, IoT platforms, system implementation, and validation with professional devices. The section on improving the accuracy of low-cost sensors provides detailed information on the integration of a simple linear regression algorithm. This enhancement allows for precise adjustments to sensor readings, ensuring reliable and accurate monitoring of water quality parameters. Lastly, the casing sensor development section outlines the design of the casing compartment and its role in effectively managing low-cost sensors during system operation. By ensuring proper protection and maintenance of the sensors, this system offers long-term and sustainable monitoring capabilities.

2. Methodology

2.1. Study area

The study was conducted on the Asian Sea Bass tank which is located at the Fish Hatchery A in International of Aquaculture and Aquatic Sciences (I-AQUAS), Universiti Putra Malaysia, Port Dickson, Malaysia (2° 27' 56.232" N; 101° 50' 58.128" E). The hatchery is situated near Port Dickson Beach, obtaining water directly from the sea for its fish tanks. Port Dickson is well-known for its coastal tourism in Peninsular Malaysia. The hatchery was selected for cultivating Asian seabass in 10-ton fish tanks, which require daily monitoring due to ongoing fish diseases. Therefore, regular monitoring of the seawater in these tanks is crucial to prevent any potential diseases from harming the fish.

2.2. IoT-based WQMS architecture

The architecture of IoT-based water quality monitoring in Asian Seabass fish tanks is introduced in this section as shown in Fig. 1. This study consists of five major parts including monitoring module, time, communication, IoT platform, system implementation, and system validation.

2.2.1. Monitoring module

To develop the water quality monitoring IoT-based, the selection of sensors and controller were required based on the criteria of Asian Seabass cultivation with the appropriate cost. Low-cost equipment for IoT systems was preferred in this study. The key parameters considered include the temperature, pH, ammonia, dissolved oxygen (DO), and electrical conductivity (EC) sensor, which was selected based on their compatibility with a common controller and crucial parameters for Asian seabass. As the name implies, the pH sensor determines the real-time acidity-alkalinity; the DO sensor measures the dissolved oxygen in water, the temperature sensor waterproof detects the water temperature, the ammonia gas sensor measures the ammonia concentration in water based on the evaporation method while the EC sensor detects the salinity level in real-time. The details of those parameters' sensors are described as follows.

- i. **Microcontroller:** The controller is a function for storing and retrieving sensor data in numerical value [12]. The Arduino Uno R3 is most widely used in the development of the WQMS aquaculture sector and is preferred as it commonly interface with different kind of sensor especially from the DFRobot brand. Arduino Uno is more affordable and ability to monitor the sensor reading with easier command language [13]. The Arduino Uno controller is shown in Fig. 2.
- ii. **Temperature sensor:** The water temperature sensor preferred in this study is the DS18B20 Temperature sensor due to it can precisely measure submerged in water with a simple 1-wire interface and is waterproof sealed with stainless steel. The low-cost sensor is applicable for the Arduino controller and a has range between $-55\text{ }^{\circ}\text{C}$ to $\pm 125\text{ }^{\circ}\text{C}$. This sensor is used to monitor the temperature in a fish tank with the precision of 0.1 steps which is more accurate than a mercury thermistor [12]. The temperature sensor is shown in Fig. 3.

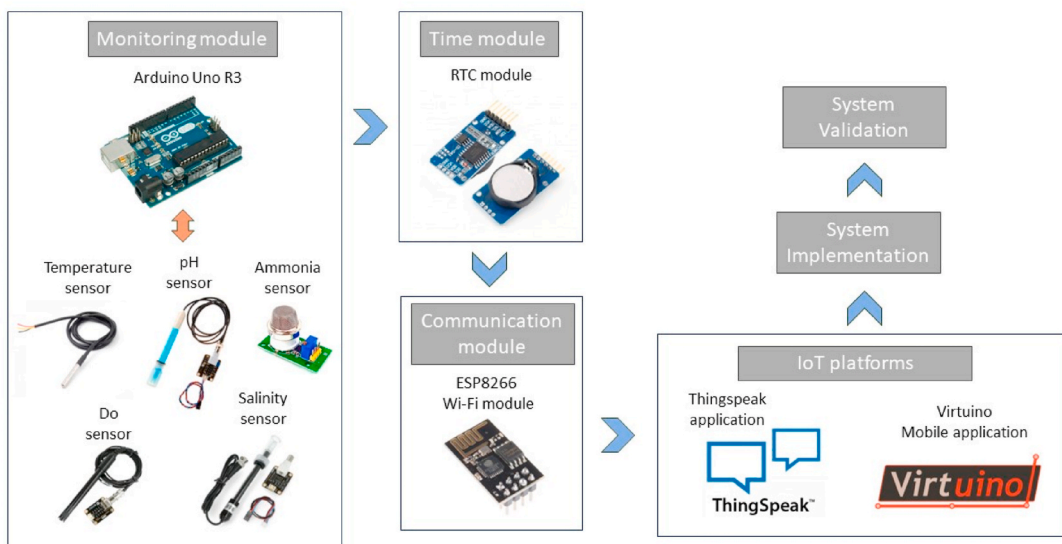

Fig. 1. Overview of water quality monitoring system using IoT based with low-cost sensors.

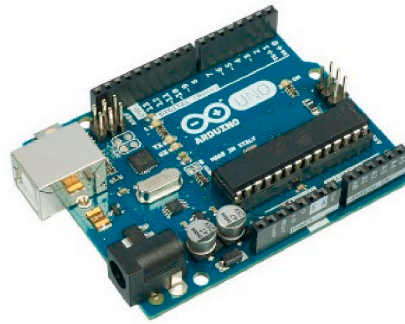

Fig. 2. Arduino uno R3



Fig. 3. DS18B20 Temperature sensor.

- iii *pH sensor*: The DFRobot Analog pH sensor (SKU SEN0161) is chosen to measure the acidity or alkalinity in the fish tank and this sensor has a range between 0 and 14. Easier to integrate with Arduino Uno and is mostly used as a low-cost sensor in WQMS for detecting the pH of the water [7]. The sensor is shown in Fig. 4.
- iv. *DO sensor*: The DFRobot Dissolved oxygen sensor is the sensor interfaced with the Arduino uno R3 microcontroller for measuring the dissolved oxygen in the water. It has a detection range between 0 and 20 mg/L. The cost-effective sensor is a galvanic probe which is an electrochemical sensor type and has a faster response time compared to the optical DO sensor probe [14]. The DO sensor used is shown in Fig. 5.
- v. *Ammonia sensor*: Ammonia is formed in the fish tank due to the breakdown of protein from fish feeds and excreted through fish gills [15]. Ammonia gas sensor MQ137 was used in this study to detect ammonia present in the water by using the vaporizing method in real time. This sensor can interface with Arduino Uno, a semiconductor type, and has a detection range between 5 and 500 mg/L. The ammonia gas sensor is shown in Fig. 6.
- vi. *Salinity sensor*: As conductivity and salinity are related, DFRobot Electrical Conductivity (DFR0300) was used to measure salinity value in fish tanks. The electrical conductivity (EC) in the water sample is influenced by the concentration and composition of dissolved salts. Furthermore, salts increase the ability of a solution to conduct an electrical current, so higher electrical conductivity indicates a high salinity level [16]. Therefore, the EC sensor DFRobot used in this study is shown in Fig. 7.



Fig. 4. DFRobot Analog pH sensor.



Fig. 5. DFRobot Dissolved oxygen sensor.



Fig. 6. Ammonia gas sensor MQ137.

Calibration of the sensor was done after the selection of sensors and controller for WQMS of Asian seabass farming. Calibrating sensors was to ensure the sensors working properly and gave an accurate reading when implemented for monitoring water quality. The calibration of sensors in this project was mostly based on the guidelines provided by their manufacturer. The sensors that needed to be calibrated were the pH sensor, dissolved oxygen sensor, ammonia gas sensor, and electrical conductivity sensor (salinity). In contrast, the temperature sensor was able to be used directly without any calibration. pH sensor was calibrated based on different kinds of buffer solution which are buffer solution of 7 (neutral) and buffer solution of 4 (acid), dissolved oxygen was calibrated by using single point calibration, and lastly, the electrical conductivity sensor (salinity) was done by calibrating using two-point calibration. Next, the threshold range limit for Asian Seabass farming was created and determined based on previous studies.

After done with the calibration, the threshold range for monitoring Asian Seabass cultivation was set in each parameter. Asian sea bass fish are warm water species that prefer temperatures ranging from 18 °C to 29 °C [17]. The suitable water temperature for Asian seabass farming in seawater is around 26 °C–32 °C. This shows that the surrounding temperature can significantly influence the internal body temperature, thus the temperature is an important key parameter that needs to be monitored [18]. Besides, pH is a crucial parameter that is needed within a certain range. This is because the epileptic variation in pH can inhibit their growth or even expose the fish to disease. A recommended desirable range of pH level for Asian sea bass is around 7.0 to 8.5 [19]. Furthermore, the recommended DO level for Asian seabass ranges from 4 to 8 mg/L [20]. A concentration of less than 3 mg/L can induce stress in fish and gradually lead to mortality. According to Ref. [21], for optimal growth and healthy thriving of Asian Seabass, the ammonia level should not exceed 0.05 ppm. In addition, a study has recommended that salinity concentration be maintained between 28 and 32 g/L for optimal daily growth [20]. Thus, the threshold limit for each parameter for this study is presented in Table 1.



Fig. 7. DFRobot Electrical conductivity sensor.

2.2.2. Time module

To keep the timing right on track, the RTC module was implemented in the system. Due to the long-term data collection interval of every 6 h, relying solely on the delay function in Arduino coding is insufficient for real-time data collection from five sensors. This can introduce potential bugs and disrupt the timing accuracy of the Arduino system. To address this issue, an RTC (Real-Time Clock) module that provides timing and date information is integrated with Arduino Uno as a special timer. It helps the sensors transfer data from the microcontroller to the IoT platform accurately and on time. The RTC module is shown in Fig. 8.

2.2.3. Communication module

To facilitate real-time monitoring of the IoT system through mobile and website applications, a data communication method was developed utilizing a Wi-Fi internet connection. An internet connection is established to enable communication using the Hypertext Transfer Protocol (HTTP), which is widely used for data transfer in IoT systems. HTTP is preferred due to its ability to maintain continuous and reliable connections for data transmission. It also supports transfer encoding, allowing efficient transfer of data between devices [22]. Hatchery A (study area), situated near a forest, faces challenges in accessing line communication due to geographical conditions. To overcome this problem, a Wi-Fi connection method is employed as a solution to retrieve and receive data in an online format. Wi-Fi provides a wireless means of data transfer, enabling seamless communication despite the limitations posed by the forested environment. To enable Wi-Fi access in the Arduino controller, a Wi-Fi module was incorporated into the system. The ESP8266 ESP 01 module was chosen as the most commonly used, cost-effective compared to other options, and can be easily integrated with Arduino Uno. Fig. 9 shows the ESP8266 Wi-Fi modules used in this system.

2.2.4. IoT platform

The IoT platform database is used to visualize the parameter data with an interactive dashboard. This platform was created to minimize labor work and easier for users to analyze the data from sensors. In this study, Thingspeak and Virtuino applications were used as common databases when using the Arduino Uno as a controller. Thingspeak application was preferred due to the ability to analyze live data and the easier of sending data collection in online storage by using REST API. Additionally, Thingspeak provides the option to incorporate plugins, which allow users to display gauges, create custom visualizations, and utilize controls in private views. Data analysis and visualization can be performed using MATLAB analytics within the Thingspeak platform [23]. Virtuino application was used for visualization in mobile applications due to the Thingspeak application at that time was still unavailable for phones. The Virtuino application is a dashboard with a graphical user interface (GUI) for managing and viewing data from physical objects and sensors [24]. This application will be used as an alarm to trigger the user if the parameter is out of range. Virtuino application linked with the Thingspeak channel to get the data online in this study.

2.2.5. System implementation

The implementation of the system is composed of two parts which are hardware and software.

IoT hardware:

First of all, the hardware components were set by connecting all the sensors to the Arduino board with the RTC module and ESP8266 Wi-Fi module in one circuit breadboard as shown in Fig. 10 by using the fritzing application. Sensors that use 5V as power sources are pH, ammonia, dissolved oxygen, and salinity sensors while the sensors that use 3.3V as power sources are temperature sensor, Wi-Fi module, and RTC module. In addition, the 4.7 k Ω resistor is added between the digital pin of the temperature sensor and 47k Ω for the ammonia sensor with its power source. The measurement of the water temperature was also utilized to automatically correct the pH, DO, and EC electrodes' output variation. The software's integrated automatic temperature adjustment (ATC) feature efficiently speeds up the accuracy of pH, DO, and EC measurements as well as salinity estimates for in-situ use [25]. Furthermore, in this section, the Nomenclature of pin configuration is also presented in Table 2.

IoT software:

For the software part, all the coding programs of sensors and other hardware instruments such as ESP 8266 and RTC module were written using an embedded C++ language and then imported into the Arduino microcontroller via the IDE. The selection of an IoT platform needs a lot of consideration, such as the ability to acquire data in real-time and the capabilities IoT platform to receive multiple data [25]. Therefore, the platforms used in this project were Thingspeak and Virtuino applications while the Wi-Fi module helps in transmitting the data, i.e., the estimated WQP in real-time. Also, data visualization and storage through the IoT platform of the Thingspeak channel were created on the websites and added all the required widgets as depicted in Fig. 11. The Thingspeak server was connected with the code by writing the write API key to the channel into the Arduino microcontroller. A Virtual dashboard was also created as shown in Fig. 12. The sensors measure the WQP following the coding and predetermined threshold limits (Table 1) as it gets

Table 1
The threshold range for the considered water quality parameters.

Parameters	Threshold range	Units	References
Temperature	26–32	Celsius	[17]
pH	7.0–8.5	pH	[19]
Dissolved Oxygen	4.0–8.0	mg/L	[20]
Ammonia	<0.02	ppm	[21]
Salinity	28–32	ppt	[20]



Fig. 8. RTC module.

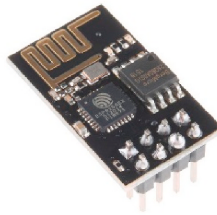

Fig. 9. ESP8266 Wi-Fi module.

powered. Then, the determined WQP values were uploaded to the Thingspeak cloud via internet connectivity. The data visualization is carried out using MATLAB programming in Thingspeak and also the Virtuino application where the results are displayed graphically and numerically.

Fig. 13 presents the procedure employed to install the IoT water quality parameter monitoring system. The sensor casing is been attached outside of the fish tank. At a certain time interval which was controlled using the RTC module, the water sample got pumped from the tank into the compartment for the measurements of the parameters in real-time. This operation loops every interval of 6 h, this implies that water quality parameters are monitored 4 times daily.

In the sensor node, these sensors are connected to an Arduino Uno R3 board. The core controller accessed the sensor values and processed them to transfer data with the help of the ESP 8266 Wi-Fi Module and update in time by using the RTC module to the IoT platform (Thingspeak and Virtuino application). The data results were recorded, stored, and displayed on both the Thingspeak server and Virtuino phone dashboard which is easier for the aqua farmer to monitor daily. The operation flowchart of the proposed system is shown in Fig. 14. If the range of each parameter is out of the limit, the alarm will be triggered in the Virtuino application based on the threshold limit in Table 1.

2.2.6. System validation

Calibrating low-cost sensors with standard solutions is an essential step to enhance their reliability; however, this method is not sufficient to ensure their accuracy. To establish the validity of these sensors, a comparison of their results with reference devices such as multiparameter probes is essential [7]. Several studies have used YSI EXO as references when assessing water quality parameters such as Kinar and Brinkman [26], Mendez-Barroso et al. [27], and Borquez Lopez et al. [8]. In this study, the water quality parameter reading obtained using YSI Professional Plus (Pro Plus) was employed to validate and ascertain the accuracy of the IoT system's results. Although there are only a few studies that have employed YSI Professional Plus for validating water quality parameters, it is noteworthy that probes from the same brand, such as YSI Exo share similar sensor measurement and operating principles with the YSI Professional Plus [28].

The YSI probe was calibrated first in the laboratory of hatchery I-AQUAS UPM using a standard solution before measuring the water quality parameter data for validation. The temperature YSI probe was verified by using a traceable thermometer. Calibrating the dissolved oxygen of the YSI probe used the percent dissolved oxygen ("DO%") method by placing the probe in air saturated with water in the calibration cup while for pH probe were calibrated with three buffer solution (pH 7, pH 4, and pH 10). Regarding the salinity probe, calibration was deemed unnecessary since it concurrently calibrates the conductivity [29]. Freshwater calibration was achieved using a 1.0 mS/cm standard, while for saltwater, a 50 mS/cm standard was employed. As for the ammonia measurement, it was not calibrated within this probe, as it is solely utilized in freshwater applications. Instead, the ammonia readings were validated using an API test kit. The measurement dataset for 3 months was used for the validation. The evaluation time was taken 2 times daily at 9:00 a. m. and 3:00 p.m. after fish feeding directly from the fish tank where the corresponding IoT reading at the same instantaneous time was taken. The obtained data set was subjected to statistical analysis and determined the level of deviations and accuracy such as the coefficient of determination (R^2), accuracy percentage, mean, minimum, and maximum value.

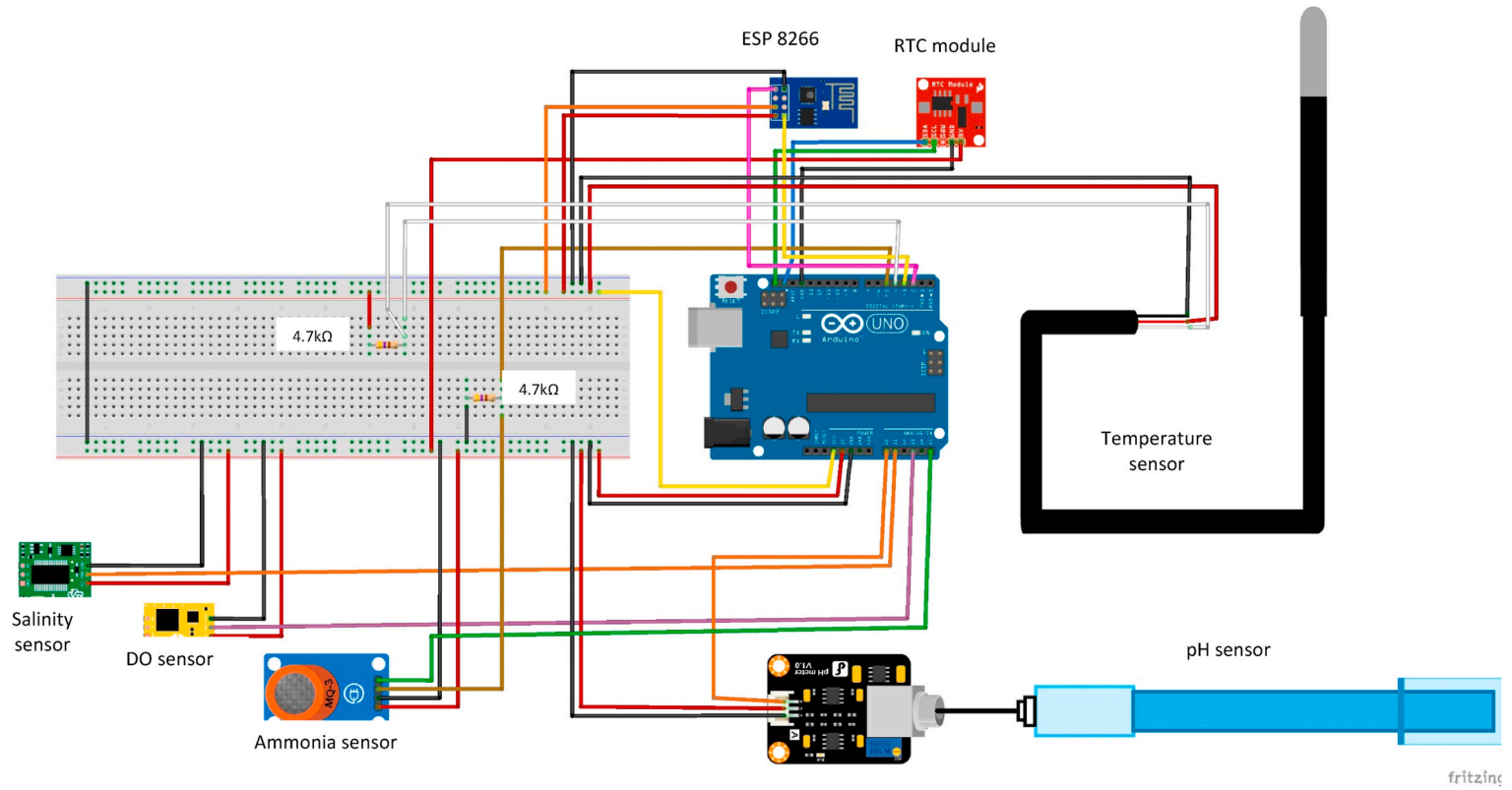

Fig. 10. Circuit diagram of the hardware system.

Table 2
Nomenclature of pin configuration.

Pin Configuration in Wi-Fi module	Connection
VCC	Power supply for the module (3.3V)
Rx	The receiver pin connects to D0 pin of Arduino Uno
Tx	The transmitter pin connects to D1 pin of Arduino Uno
RST	Reset pin connects to 3.3V
GND	Common ground
Pin Configuration in the RTC module	
SCL	SCL pin connects to SCL pin of Arduino Uno
SDA	SDA pin connects to SDA pin of Arduino Uno
VCC	Power supply to RTC module
GND	Common ground
Pin Configuration in Temperature sensor	
VCC	Power supply to sensor
DAT	The digital signal output connects to D4 of Arduino Uno
GND	Common ground
Pin Configuration in pH sensor	
+5V	Power supply for pH sensor
-	Common ground
A	Analog signal output connects to A0 pin of Arduino Uno
Pin Configuration in Ammonia sensor	
VCC	Power supply to sensor
GND	Common ground
DOUT	The digital signal output connects to D5 of Arduino Uno
AOUT	Analog signal output connects to A5 pin of Arduino Uno
Pin Configuration in DO sensor	
+5V	Power supply to sensor
-	Common ground
A	Analog signal output connects to A3 pin of Arduino Uno
Pin Configuration in Salinity sensor	
+5V	Power supply to sensor
-	Common ground
A	Analog signal output connects to A2 pin of Arduino Uno

2.3. Improvement of sensor accuracy

Linear regression analysis is often used to establish the link between two or more variables. The dependent variable (response) in a regression model is combined with additional factors that are expected to provide information regarding the behavior of the response-independent variable [30]. In this study, the proposed technique is based on applying Simple linear regression on sensors of IoT-WQMS to improve the sensors system accuracy.

In a basic linear regression model, there's a single independent variable, denoted as X_i for subjects $i = 1, \dots, n$ as shown in Equation (1). This variable exhibits a linear connection with the dependent variable Y_i , and this relationship is expressed by the following formula involving regression parameters:

$$Y_i = aX_i + b + e_i \tag{1}$$

The least-squares method is a widely applied technique for determining the parameters (like intercept and slope) that define the best-fitting line for a given set of data. This line helps predict the value of Y based on X. The objective is to find the right combination of parameters that minimizes the total of the squared differences between predicted and actual Y values based on the following linear regression based on Equation (2):

$$Y = aX + b \tag{2}$$

In this equation, X represents the independent variable, b stands for the intercept, and a represents the slope [34–36]. The value of the slope, denoted as 'a', is computed using Equation (3)

$$a = -b\bar{X} + \bar{Y} \tag{3}$$

while the intercept is calculated according to Equation (4)

$$b = \frac{\sum_{i=1}^n (X_i - \bar{X})(Y_i - \bar{Y})}{\sum_{i=1}^n (X_i - \bar{X})^2} \tag{4}$$

ThingSpeak™ Channels - Apps - Devices - Support - Commercial Use How to Buy RJ

Water Quality Monitoring System (IAQUAS)

Channel ID: 1649792
 Author: mwa0000024521661
 Access: Public

Water quality monitoring system for Seabass Fish (Siakap) in I-Aquas
 water quality, ph, temperature, ammonia, do, salinity, seabass

Private View Public View **Channel Settings** Sharing API Keys Data Import / Export

Channel Settings

Percentage complete 70%

Channel ID 1649792

Name Water Quality Monitoring System (IAQUAS)

Description Water quality monitoring system for Seabass Fish (Siakap) in I-Aquas

Field 1	Temperature	<input checked="" type="checkbox"/>
Field 2	pH	<input checked="" type="checkbox"/>
Field 3	Ammonia	<input checked="" type="checkbox"/>
Field 4	DO	<input checked="" type="checkbox"/>
Field 5	Salinity	<input checked="" type="checkbox"/>

Help

Channels store all the data that a ThingSpeak application collects. Each channel includes eight fields that can hold any type of data, plus three fields for location data and one for status data. Once you collect data in a channel, you can use ThingSpeak apps to analyze and visualize it.

Channel Settings

- Percentage complete:** Calculated based on data entered into the various fields of a channel. Enter the name, description, location, URL, video, and tags to complete your channel.
- Channel Name:** Enter a unique name for the ThingSpeak channel.
- Description:** Enter a description of the ThingSpeak channel.
- Field:** Check the box to enable the field, and enter a field name. Each ThingSpeak channel can have up to 8 fields.
- Metadata:** Enter information about channel data, including JSON, XML, or CSV data.
- Tags:** Enter keywords that identify the channel. Separate tags with commas.
- Link to External Site:** If you have a website that contains information about your ThingSpeak channel, specify the URL.
- Show Channel Location:**

Fig. 11. Setting channel in Thingspeak website.



Fig. 12. Dashboard display in the Virtuino application.

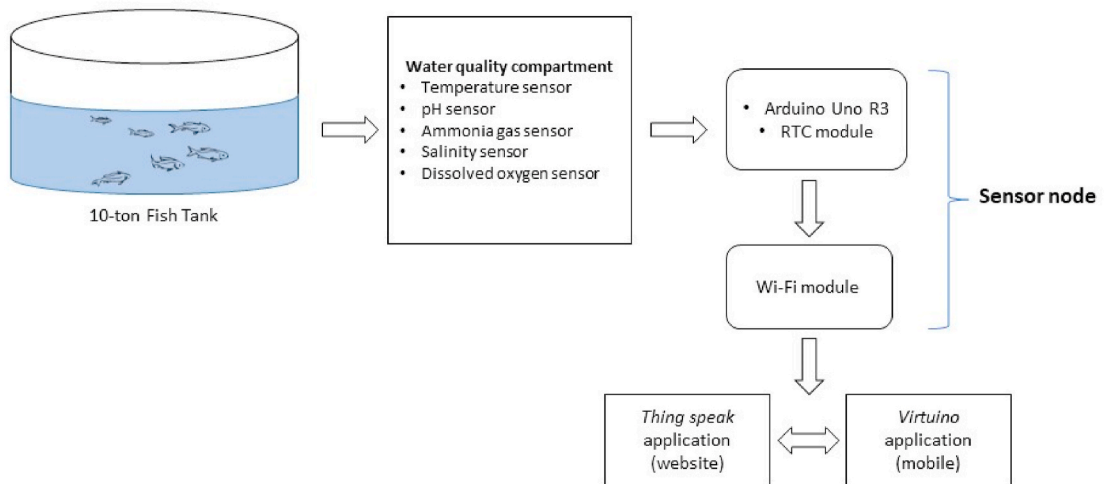

Fig. 13. The flowchart of the implemented IoT water quality parameter monitoring system.

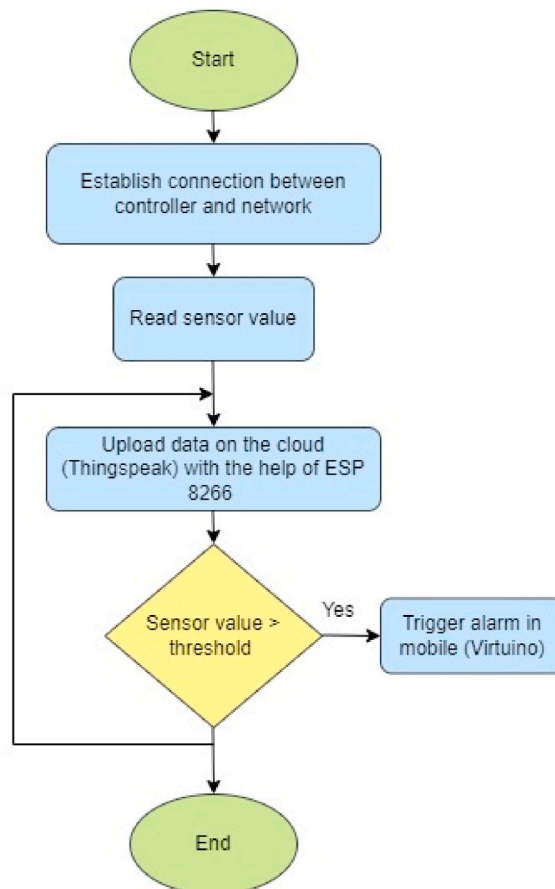

Fig. 14. Flowchart of overall system.

The mathematical shows the simple linear regression calculated based on theoretical which has the same equation with the statistical analysis of the graph in Microsoft Excel using trendline under linear Equation (2) is displayed as stated in the Microsoft Excel chart. Equation (2) will be used to integrate into the IoT coding system to automatically correct the data which had collected from the sensor system. This integration will lead to an automatic enhancement in accuracy as soon as the data is collected. The simple linear

regression equation for accuracy improvement is derived from the statistical analysis that validated the IoT-collected data against the YSI Professional Pro data over three months.

2.4. Development of casing sensor for IoT-WQMS in aquaculture tank

The sensor casing was designed to extend the lifespan of the sensors and facilitate their optimal utilization, leading to improved accuracy in sensor readings. The main reason for creating this compartment is because pH and EC sensors cannot be placed in liquid for a long time to measure, it is labor-intensive and time-consuming to take the probe testing on each tank in a fixed time. The self-designed casing sensor was developed to protect the pH probe submerged for a long period as shown in Fig. 15 by using AutoCAD 3D. The construction of the sensor casing for water quality monitoring involved careful consideration of essential elements such as probe size, ease of cleaning inside the compartment, the material used, and simplified installation alongside the controller. These features were thoughtfully incorporated to ensure an ideal casing design for accurate measurements, especially when using sensors that cannot be immersed for extended periods. The dimension of the casing sensor was recommended in a rectangle shape as it is easier to install the sensors neatly in the casing and interactive to display for user monitoring. Once the water in the casing sensor, where all the sensors are submerged, reaches a specific level, the pump will be deactivated. This will result in a gradual discharge of water at a reduced flow rate, potentially extending the duration of data collection by the sensors, as shown in Fig. 16.

3. Result and DISCUSSION

3.1. IoT-based WQMS implementation

3.1.1. Calibration of sensors

Calibrating the sensors is a crucial step in enhancing their performance and sensitivity. After assembling the circuit of the IoT system and conducting thorough testing, the calibration process was carried out for each sensor. The pH sensor was calibrated using standard buffer solutions, namely pH 7 and pH 4. The Analog pH sensor demonstrated an accuracy of ± 0.05 pH for both buffer solutions. For the Analog DO sensor, calibration was performed using the MW600 Standard Portable Dissolved Oxygen meter, resulting in an accuracy of ± 0.36 mg/L. The Analog Electrical conductivity sensor underwent calibration with a refractometer to correlate the EC value with the salinity value, yielding an accuracy of ± 0.29 ppt, and lastly, the ammonia gas sensor was calibrated with an ammonia test kit, achieving an accuracy of around ± 1.13 ppm. The calibration process ensures that the sensors provide precise and reliable measurements, making them well-suited for accurate water quality monitoring in the IoT system. All the parameter calibration procedures were meticulously conducted within the controlled environment of the Hatchery A (I-AQUAS) laboratory. Once the calibration process was completed, the sensors were then subjected to validation using the high-accuracy YSI Professional Plus. In

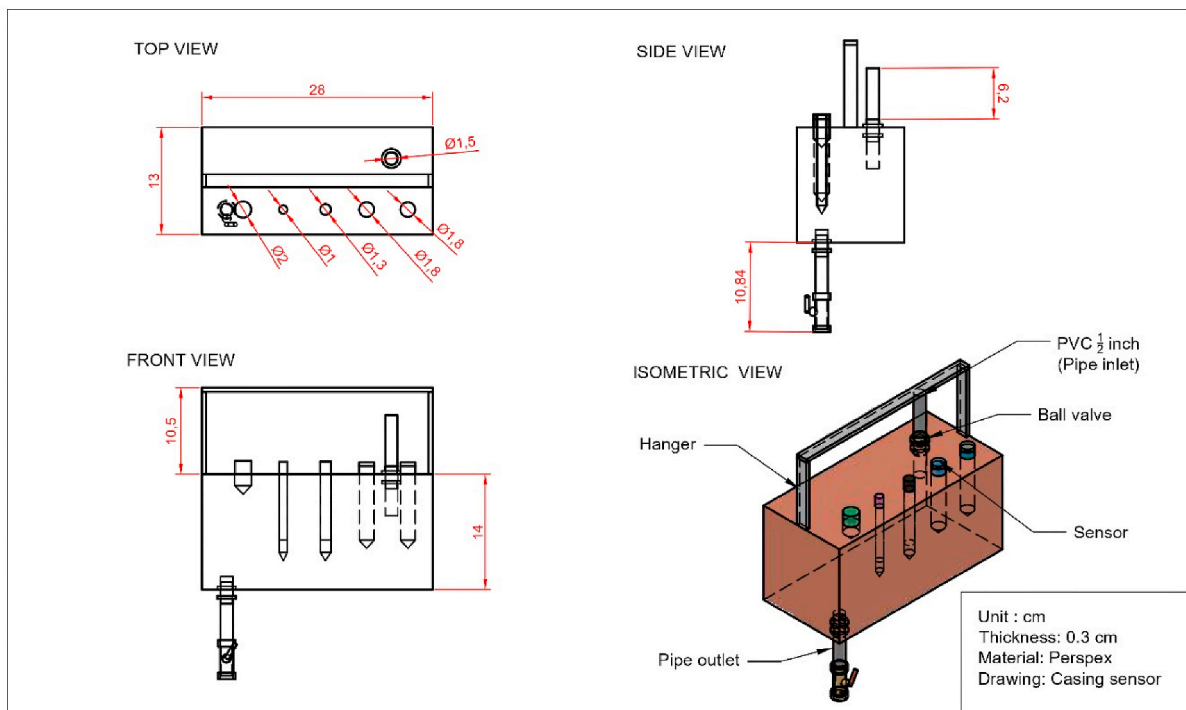

Fig. 15. Sketch of casing sensor using AutoCAD 3D.

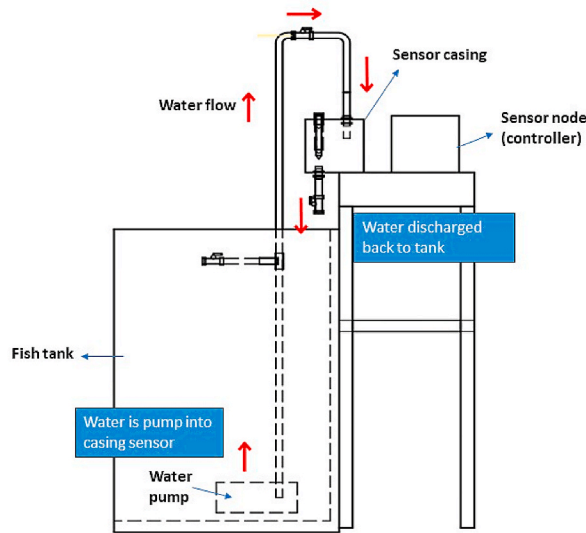

Fig. 16. Casing sensor used in IoT-based WQMS aquaculture tank.

summary, the thorough calibration process followed by validation with the YSI Professional Plus guarantees the precision and dependability of the sensors, making them well-suited for accurate water quality monitoring in various aquatic farming applications.

3.1.2. IoT hardware

The water quality monitoring system by using low-cost sensors and IoT technology was successfully installed at the fish tank as shown in Fig. 17. Sensors were able to detect the parameter value data such as water temperature, pH, dissolved oxygen, salinity, and ammonia in the fish tank, and then the value obtained was processed by the core controller (Arduino Uno R3). The power source for the microcontroller by using the power adapter direct current plug was able to power up the Arduino Uno every day without having the overload current. The Real-Time Clock (RTC) module effectively maintained accurate time tracking, allowing for precise data logging. Furthermore, the collected data was seamlessly transmitted to IoT platforms through the integration of the ESP8266 Wi-Fi module.

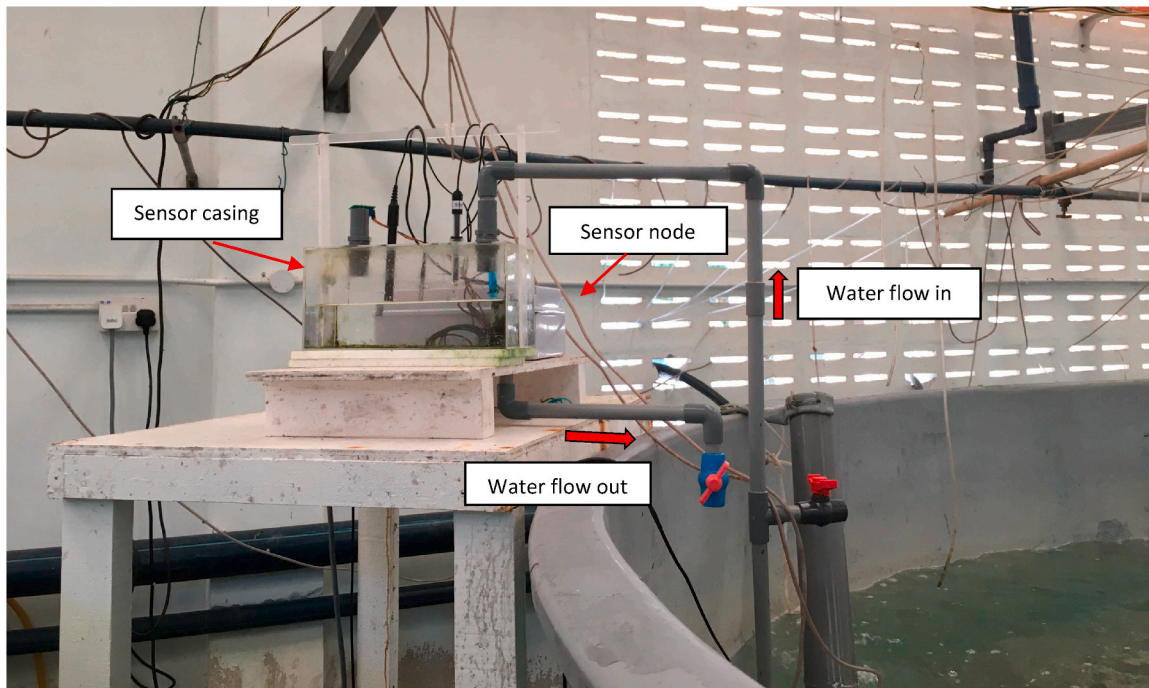

Fig. 17. The completed installment of IoT-WQMS with self-designed casing sensor in Asian Seabass fish tank.

Once a stable and appropriate connection was established, the IoT system autonomously facilitated the transfer of data to the Thingspeak and Virtuino applications.

The project utilizes a 9V 1A direct current (DC) plug power adapter. This choice was made for its compatibility and effectiveness in powering the Arduino microcontroller over extended periods. The Arduino Uno is recommended to be powered within the 9V–12V range. To guarantee the stability and uninterrupted performance of the Arduino board and all active IoT system components (as listed in Table 3), a power adapter with a minimum current rating of 250 mA was chosen. This calculation was based on the total current consumption of all components, ensuring the robust operation of the Arduino board.

The results demonstrate that the selected power supply enabled the Arduino controller to operate the system flawlessly for a continuous three-month duration. Throughout this period, no issues of overheating or inadequate power supply were encountered. The consistent data uploads to the designated website validate the reliable and sustained operation of the IoT system. The choice of an appropriate power supply has played a crucial role in ensuring the system's efficiency and effectiveness in carrying out its intended functions.

Data transmission in this project relied on serial communication between the Arduino board and the ESP8266 Wi-Fi modules, with the ESP8266 Wi-Fi module providing direct access to the microcontroller. The location site chosen for this project possessed a robust Wi-Fi range, making the Wi-Fi module an optimal choice for transmitting water quality data from in-situ measurements to IoT platforms. The ESP8266 Wi-Fi module was selected due to its favorable attributes, including high speed, enhanced processing power, and cost-effectiveness. These qualities render it highly reliable for remote water quality monitoring applications. The module's capability to transmit data over Wi-Fi allows for efficient and seamless integration into the IoT system, ensuring that the measured water quality parameters are promptly and accurately delivered to the designated platforms. By leveraging the ESP8266 Wi-Fi module's features, this project successfully achieved remote monitoring of water quality, providing real-time data updates for informed decision-making and enhanced environmental management in the hatchery setting.

3.1.3. IoT software

In the software results, the collected sensor data were successfully displayed on both the website and mobile application of the Thingspeak server, enabling convenient data analysis and monitoring, as illustrated in Fig. 18. Additionally, the Virtuino application provided an interactive dashboard that allowed users to easily monitor water quality parameters, as depicted in Fig. 19 throughout 3 months. The gathered data from the Thingspeak website could be exported and opened in Excel format, facilitating further analysis and processing for research or decision-making purposes. Despite the successful transfer of all data to the IoT platform, occasional delays in data display were observed in the Thingspeak and Virtuino applications. This delay could be attributed to temporary disruptions in the Wi-Fi connection in the study area, possibly occurring during maintenance activities in the hatchery. As a result, the monitoring system demonstrated its dependence on the availability and stability of the Internet network. However, despite the occasional delays, the system continued to perform effectively once the Wi-Fi connection was restored. The data was accurately displayed on the dashboard, providing users with real-time insights into water quality parameters. Furthermore, the Virtuino application featured an alarm system that proved highly beneficial. When sensor values fell outside the predefined range, the application promptly alerted the user via an alarm and displayed a corresponding alarm message, as shown in Fig. 20. This alert mechanism enabled users to take immediate action in response to critical variations in water quality, allowing for timely intervention and maintenance measures.

3.1.4. IoT platform (thingspeak application)

As shown in Fig. 21, field 1 in the Thingspeak server is updated with their corresponding values in the temperature unit. The server receives updates every 6 h, and the charting platform depicts temperature variations for 60 days. The three months of data from Excel were exported from the Thingspeak server to analyze the validation results. The water temperature in the Asian seabass tank, as depicted in the displayed chart, falls within the optimal range for Asian seabass cultivation, ranging from 24 °C to 31 °C. These temperature values are considered acceptable for maintaining a suitable environment for the growth of Asian seabass. However, there is a notable drop in water temperature to 20 °C, as recorded in field 1 of the Thingspeak server. This occurred at approximately 4:00 a. m., and it is likely due to the surrounding conditions during the data recording. At the same time, the Virtuino application triggered a message alert due to the low temperature, as indicated in Fig. 20.

Fig. 22 illustrates the data chart in the Thingspeak server, specifically displaying the pH values in the Asian seabass tank. The pH levels in this system are within the optimal range for Asian seabass cultivation, falling between 6.5 and 8.5. This indicates that the pH conditions are suitable for the healthy growth of Asian seabass.

Table 3
List of components with its current consumption of devices in IoT system.

Components	Current consumption (mA)
Dfrobot Analog pH sensor	0.015
Dfrobot Analog DO sensor	0.07
Dfrobot Analog EC sensor	0.025
MQ137 Ammonia Gas sensor	150
DS18B20 Temperature sensor	0.08
RTC module	0.003
ESP8266 Wi-Fi module	12
<i>Total current consumption (mA)</i>	<i>162.193</i>

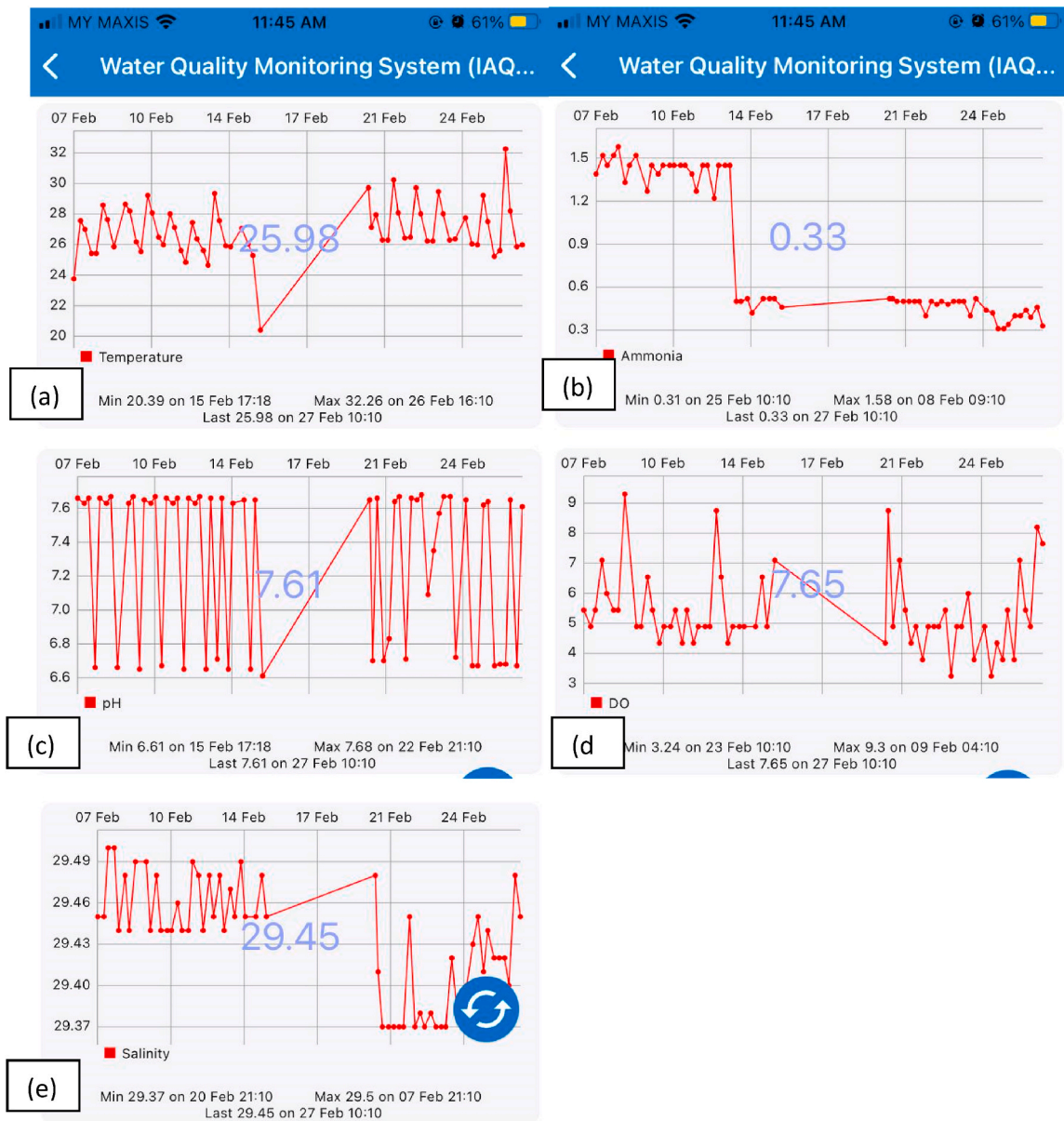

Fig. 18. Data visualization in Thingspeak mobile application where (a) water temperature, (b) ammonia, (c) pH, (d) dissolved oxygen and (e) salinity value in respectively.

Additionally, Fig. 23 shows the line graph representing the ammonia data in the Thingspeak field 3 charts. The ammonia values range between 0 and 2 ppm. On February 4th, there was a spike in ammonia levels, coinciding with a corresponding increase in pH. This can be attributed to the fact that when pH levels rise, ammonium in the water undergoes conversion into toxic ammonia (NH₃), which can lead to fish diseases [31]. The elevated pH level and increased ammonia on February 4th were a result of the maintenance cleaning of the filter, making it difficult for the bacteria to perform nitrification, which is crucial for removing ammonia and nitrate from the fish tank.

Fig. 24 demonstrates the updating of data values for dissolved oxygen (DO) and salinity from the Analog DO sensor and Analog EC sensor, respectively, into the Thingspeak server. The salinity measurement values in parts per thousand (ppt) are recorded in field 5, while the DO values in milligrams per liter (mg/L) are recorded in field 4.

According to the displayed chart, the dissolved oxygen levels in the fish tank range from 3.4 to 9.4 mg/L, with most readings falling within 6–7 mg/L. These values are within the acceptable range for fish survival. However, if the dissolved oxygen value drops below 3 mg/L, the system will issue an alert to the user, prompting them to take further management actions. It's important to monitor the dissolved oxygen levels closely, as insufficient oxygen can lead to adverse effects on the health and well-being of the fish in the tank.

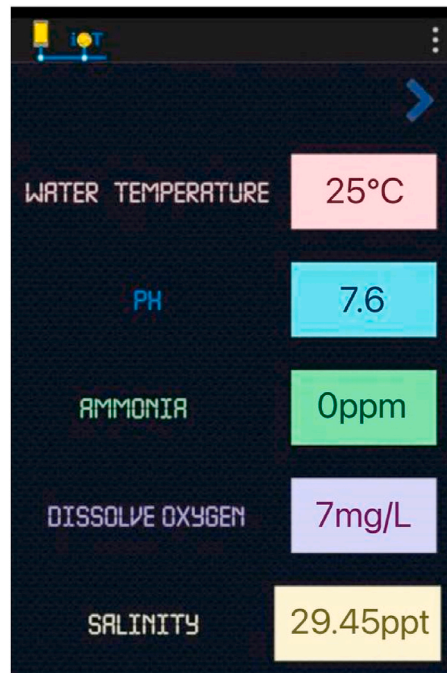

Fig. 19. Dashboard of data visualization in the Virtuino application.

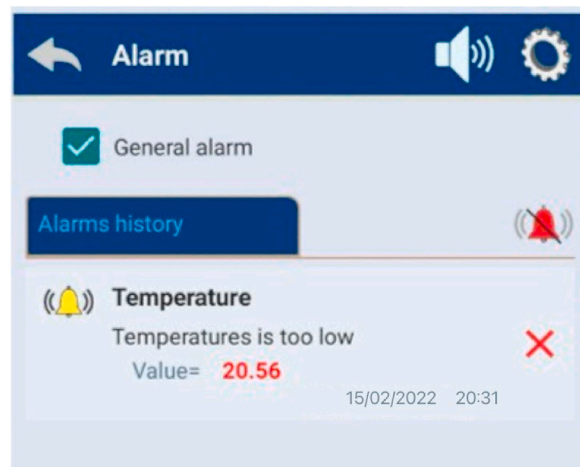

Fig. 20. The message shows a description of the triggered alarm.

Asian Sea bass can adapt to different kinds of environments and types of water either in freshwater, brackish water, or saltwater. However, culture in seawater can reduce the disease of fish [19]. As can be seen in Fig. 25 under field 5 of the presented chart, the salinity variation in the fish tank is in the 28–30 ppt range, which is ideal for cultivating Asian sea bass. The water parameters taken during this project showed good results as all water quality parameters are within the acceptable range for culturing Asian sea bass in the fish tank.

The data collected from the monitoring system showcases positive and reliable results, indicating the effective performance of all sensors and IoT equipment throughout the 3-month validation period. Furthermore, the system's exceptional functionality is evidenced by its continuous operation for an impressive two-year duration in the institute, following its initial validation in February 2022. The system's data, available at the link <https://thingspeak.com/channels/1649792>, has consistently provided valuable insights over this extended period, maintaining accurate and consistent readings. The sustained quality of the sensors is attributed to regular monthly calibration, ensuring their reliability and precision. Given the system's critical nature and the necessity for accurate data, regular calibration is a fundamental practice to uphold the high standard of monitoring required for daily operations.

In conclusion, the successful and continuous operation of the monitoring system, together with its impressive data collection and analysis, underscores its effectiveness and value in providing essential water quality information. The regular calibration and

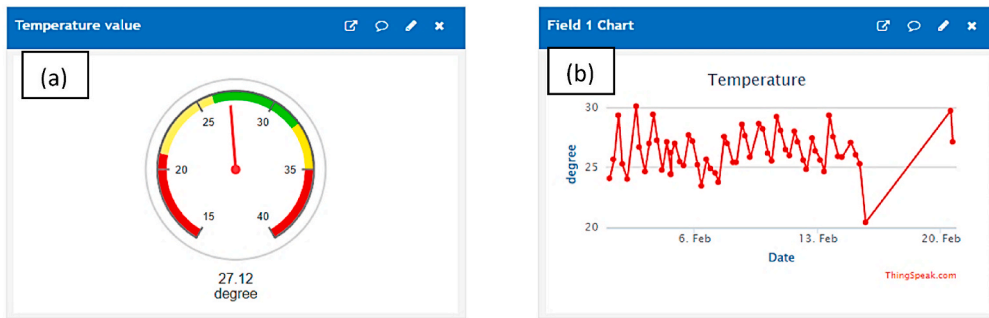

Fig. 21. (a) Temperature value data with (b) chart displayed on Thingspeak website.

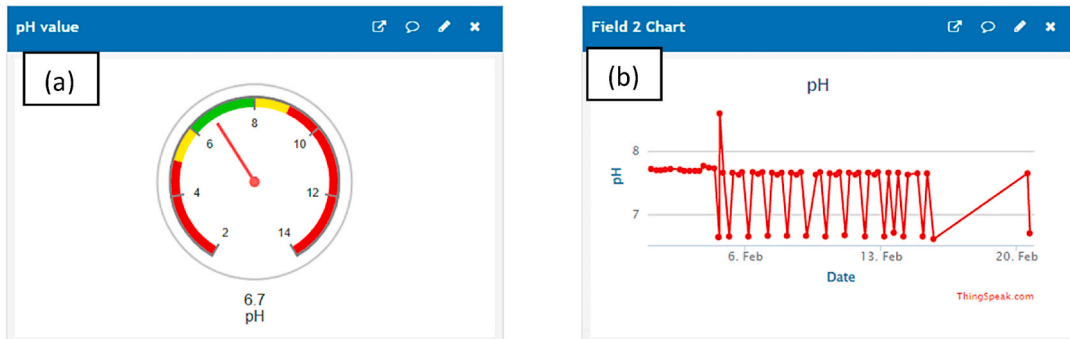

Fig. 22. (a) The pH value data with (b) chart displayed on the Thingspeak website.

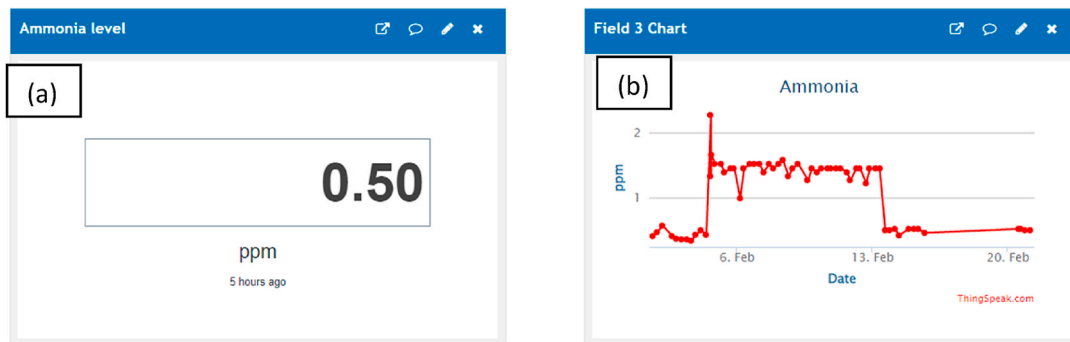

Fig. 23. (a) The ammonia value data with (b) chart displayed on the Thingspeak website.

consistent attention given to the system have contributed to its exceptional performance and reliability over the extended period of operation.

3.2. Result of system validation within 3 months using professional devices

The data collected through the IoT system was validated with the actual direct water quality data using the YSI Professional Plus (Pro Plus) probe. This validation was achieved by conducting simultaneous measurements inside the sensor casing at 6-h intervals for three months. The results of this validation are presented in Fig. 26. The difference values obtained from the validation were found to be reasonably consistent, with certain values showing a correlation coefficient (R^2) of 0.8. This positive correlation indicates a good match between the IoT system's readings and the data obtained from the YSI probe. The correlation coefficient analysis achieved values higher than 0.5, further confirming the reliability and accuracy of the IoT system's measurements. In terms of individual water quality parameters, the pH sensor demonstrated the highest coefficient of determination value (R^2) of 0.8949, resulting in an impressive system accuracy of 98%. The water temperature readings showed an R^2 value of 0.8204, corresponding to a system accuracy of 97%. For ammonia measurement, the coefficient value obtained was 0.8167, with a system accuracy of 80% while the

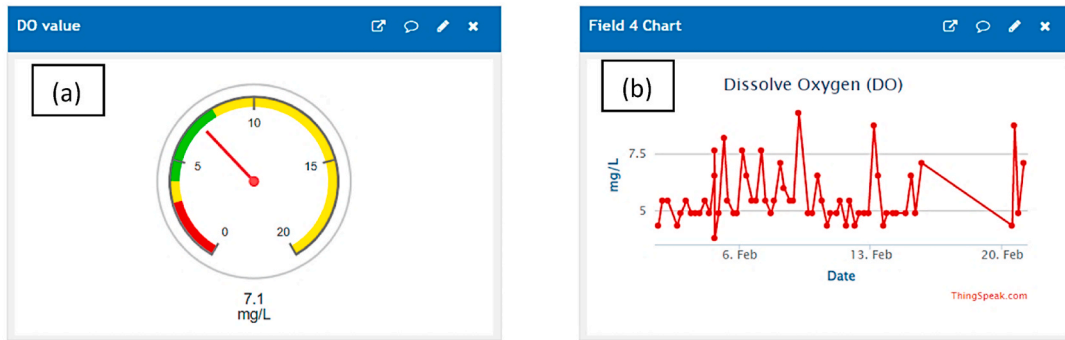

Fig. 24. (a) The DO value data with (b) chart displayed on the Thingspeak website.

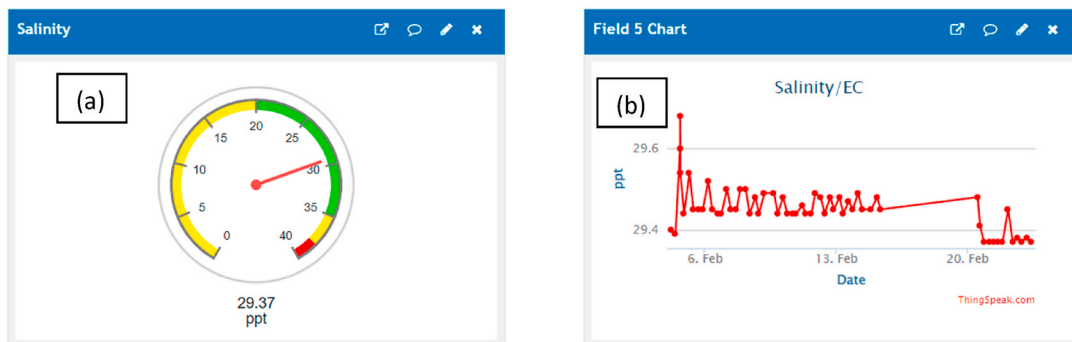

Fig. 25. (a) The salinity value data with (b) chart displayed on the Thingspeak website.

dissolved oxygen (DO) sensor had a lower R^2 value of 0.806, leading to a system accuracy of 76%. Lastly, the salinity value readings achieved a coefficient value of 0.8745, with a system accuracy of 96%. The accuracy analysis for temperature, pH, ammonia, dissolved oxygen, and salinity value data obtained from the IoT system is summarized in Table 4.

Therefore, the validation process demonstrates the reliability and effectiveness of the IoT system in measuring various water quality parameters, with most parameters achieving high accuracy levels. The positive correlation between the IoT system's data and the YSI probe readings reinforces the system's capability for precise and dependable water quality monitoring.

3.3. Results improvement of accuracy sensors

The validation data for water quality parameters already demonstrate favorable results within a good range for regression analysis. However, to further enhance the accuracy of each parameter's value, the IoT coding system can be improved by incorporating simple linear regression equations. As presented in Fig. 26, the IoT platform effectively displays the monitored data, offering real-time information on water quality parameters, including temperature, pH, ammonia, dissolved oxygen, and salinity values. To refine the system's accuracy, additional data was collected over a period of 5 days, yielding promising results that surpassed the range of R^2 values obtained from the validation data. This indicates the potential for improved precision in the measurements. To exploit these findings and enhance accuracy, the regression equations for each water quality parameter were successfully integrated into the Arduino programming, as outlined in Table 5. This equation of simple linear regression was obtained from the validation of IoT-WQMS sensors with a YSI probe. This integration allows the system to employ the regression equations to make more precise adjustments to the sensor readings, consequently improving the accuracy of the reported values. The linear regression equation was integrated in IoT-WQMS programming to improve the accuracy of sensors as shown in Fig. 27.

The system's enhancements have led to a significant improvement in the accuracy of the measured parameters. The temperature accuracy has been successfully maintained at ± 0.10 °C, while the pH, dissolved oxygen, ammonia, and salinity accuracy have been achieved at ± 0.12 pH, ± 0.046 mg/L, ± 0.02 ppm, and ± 0.09 ppt, respectively.

Moreover, the average relative errors for temperature, pH, ammonia, dissolved oxygen, and salinity have been substantially reduced, indicating a higher level of precision. The average relative error values for these parameters are now at 0.27%, 1.56%, 4.8%, 0.57%, and 0.28%, respectively as shown in Table 6. These relative error values demonstrate a smaller range compared to the values obtained from the YSI probe, signifying the enhanced accuracy and reliability of the IoT sensors. Based on these results, it is evident that the application of simple linear regression has yielded statistically significant findings [11].

With enhanced accuracy and precision, the IoT system can now provide more reliable data, ensuring the precise monitoring of

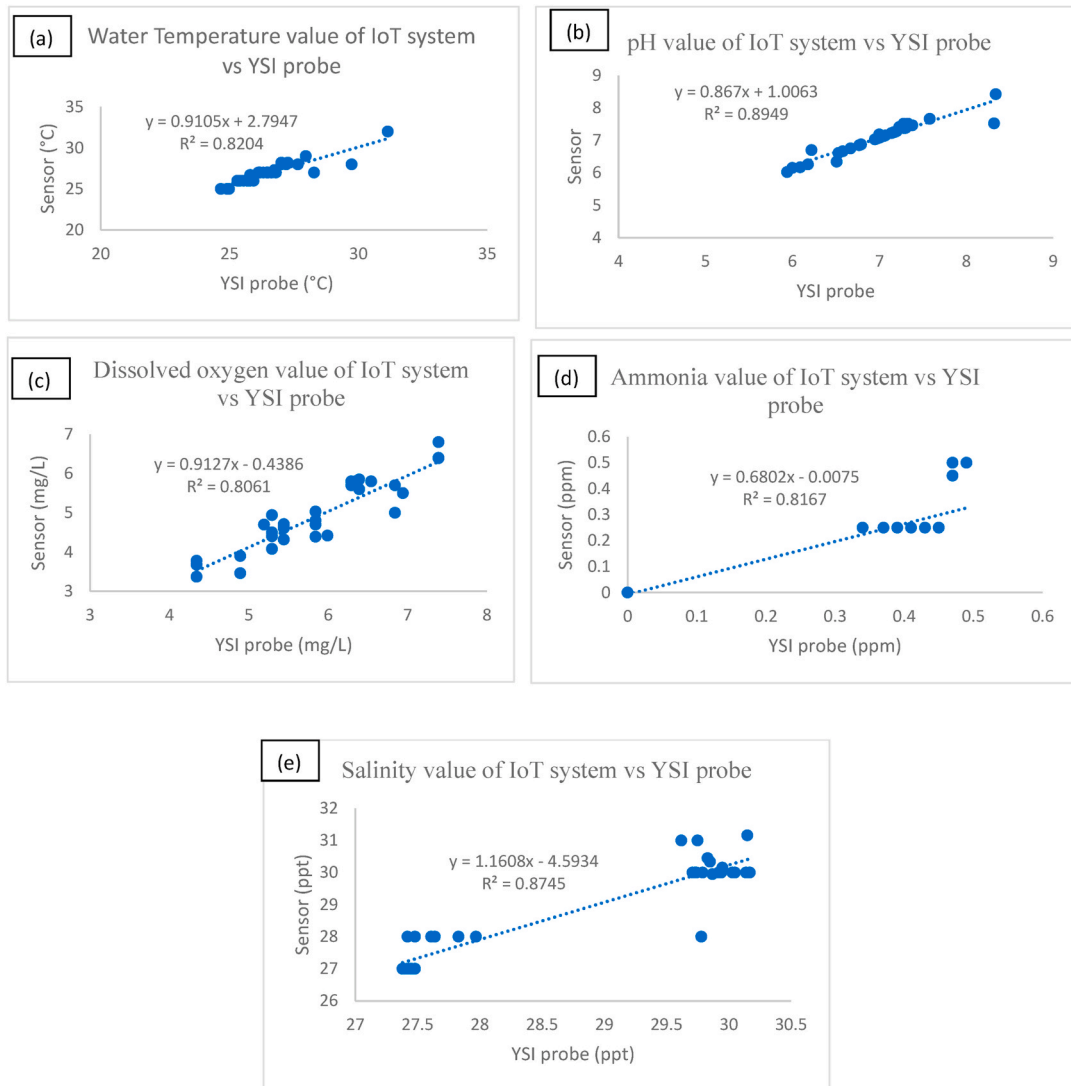

Fig. 26. Linear plot of water quality parameters sensor such as (a) water temperature, (b) pH, (c) dissolved oxygen, (d) ammonia and (e) salinity value validates with YSI probe by using the corresponding R-value.

Table 4

Accuracy analysis of water temperature, pH, ammonia, dissolved oxygen, and salinity value from IoT system measurement.

Parameters	Accuracy Analysis				
	Mean	Min	Max	Accuracy (%)	Coefficient of determination (R2)
Water temperature (°C)	26.48	24.66	31.14	98	0.8203
pH	7	6.50	8.34	97	0.8949
Ammonia (ppm)	0.6	0	2.00	80	0.813
Dissolved oxygen (mg/L)	5.29	4.34	7.39	76	0.8061
Salinity (ppt)	28.73	27.38	30.17	96	0.8745

water quality in fish tanks. This enhancement ensures that the system’s measurements align closely with the standard reference data from the YSI probe, making it a valuable and reliable tool for real-time water quality assessment and environmental management.

3.4. Development of casing sensor

To prolong the lifespan of the sensors, a self-design casing sensors was introduced and successfully developed by using suitable

Table 5
Regression equation for improvising accuracy sensor's value.

Parameters	Regression equation
Water temperature (°C)	$y = 0.9105x + 2.7947$
pH	$y = 0.867x + 1.0063$
Ammonia (ppm)	$y = 0.6782x - 0.006$
Dissolved oxygen (mg/L)	$y = 0.9127x - 0.4386$
Salinity (ppt)	$y = 1.1608x - 4.5934$

```

modiy_after_regression_2$

// ===== Read Ammonia values

float VRL; //Voltage drop across the MQ sensor
float Rs; //Sensor resistance at gas concentration
float ratio; //Define variable for ratio

VRL = analogRead(MQ_sensor)*(5.0/1023.0); //Measure the voltage drop and convert to 0-5V
Rs = ((5.0*RL)/VRL)-RL; //Use formula to get Rs value
ratio = Rs/Ro; // find ratio Rs/Ro

float ppm = pow(10, ((log10(ratio)-s)/m)); //use formula to calculate ppm
double percentage = ppm / 10000; //Convert to percentage
float ammonial = 0.6782*percentage - 0.006;
Serial.print("Ammonia = ");
Serial.print(ammonial);
Serial.print(" ppm");
Serial.print(" / ");
    
```

Fig. 27. The regression equation (red box) integrated into Arduino coding IoT WQMS for improving the sensor accuracy.

Table 6
The comparison between YSI probe values with IoT sensor values after improvising using regression analysis.

Parameters	Day	YSI probe values	IoT sensor values	Relative error %	Pearson coefficient correlation (R ²)
Temperature (°C)	1	27.19	27.34	+0.55	0.9818
	2	27.44	27.50	+0.21	
	3	27.15	27.21	+0.22	
	4	27.44	27.49	+0.18	
	5	26.69	26.75	+0.22	
pH	1	8.1	8.14	+0.49	0.9744
	2	7.74	7.81	+0.90	
	3	7.12	7.46	+4.77	
	4	8.45	8.57	+1.42	
	5	8.53	8.55	+0.23	
Ammonia (ppm)	1	0.5	0.60	+20.0	0.9681
	2	0.25	0.26	+4.00	
	3	0.25	0.23	-8.00	
	4	0.25	0.26	+4.00	
	5	0.5	0.52	+4.00	
Dissolved oxygen (mg/L)	1	5.9	5.67	-3.89	0.9242
	2	6.3	6.53	+3.65	
	3	6.4	6.61	+3.28	
	4	6.3	6.09	-3.33	
	5	7.3	7.53	+3.15	
Salinity (ppt)	1	31.15	31.25	+0.32	0.9839
	2	31.2	31.21	+0.16	
	3	31.58	30.48	-0.32	
	4	31.38	31.58	+0.63	
	5	31.2	31.4	+0.64	

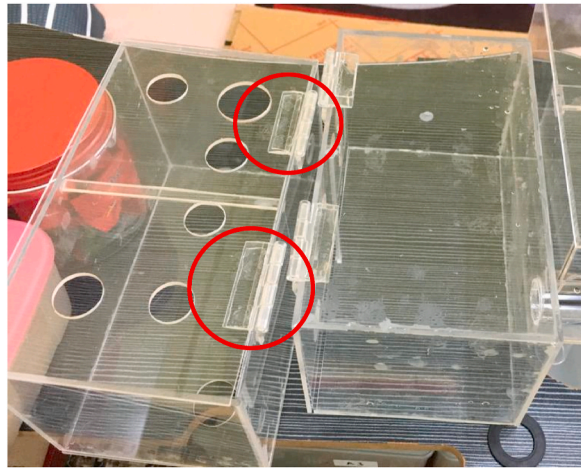

Fig. 28. The acrylic hinge was attached at the casing sensor in the red circle.

materials for monitoring the water quality. A modified desk was the base for the sensor casing and the sensor was able to stabilize its position in a hanging state as shown in Fig. 29. When the pump is turned off, the stability of the sensor inside the casing is necessary to ensure that the sensor does not come into contact with the water as some of the sensors were not recommended to be submerged for long periods. In addition, water flowed smoothly within PVC pipes due to the water pump's reliable power and flexible positioning as shown in Fig. 17.

In addition, further improvements were made to the sensor casing during installation. A Perspex or Acrylic hinge was introduced as shown in Fig. 28 to facilitate easy cleaning of moss and debris that may accumulate over time when the casing is deployed for extended periods. This enhancement ensures that the casing remains in optimal condition and maintains accurate readings throughout its usage. Furthermore, a custom stand was designed to securely position the sensor within the casing as shown in Fig. 29. This stand ensures a precise fit, promoting stable sensor positioning during operation. By hanging the sensor with a purpose-built stand, potential misalignments or disturbances that could affect measurement accuracy are minimized, enhancing the reliability of the water quality monitoring system.

The development of the sensor casing has proven successful, enabling real-time data collection with precise values. Notably, the system's sensors have exhibited exceptional longevity, surpassing the typical service life of sensors, which is approximately one year. The system has remained operational for nearly two years since its validation in February 2022, as evident from the continuous data collection available at the link <https://thingspeak.com/channels/1649792>. This longevity can be attributed to the sensors' intelligent activation, wherein they only read values when the water is pumped, thereby extending their service life. Throughout the operational

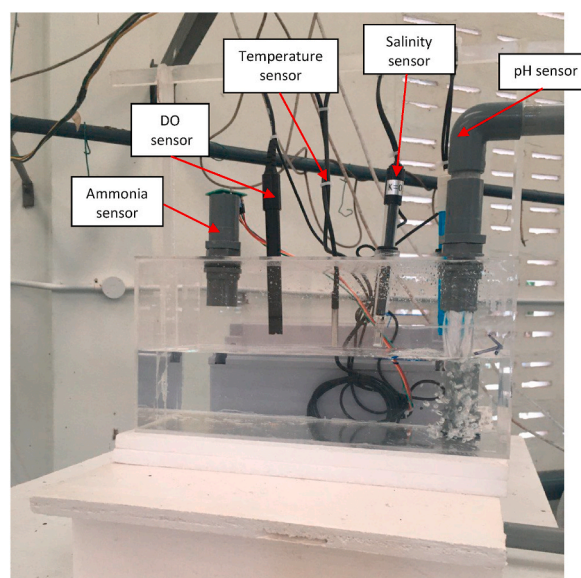

Fig. 29. The sensor casing where all the sensors will be sensed in this compartment.

period, the system has consistently provided impressive and accurate data, showcasing the reliability and quality of the sensors. This is facilitated by the regular monthly calibration, ensuring the sensors' continued accuracy over time. The daily attention required for monitoring attests to the system's critical role in facilitating real-time water quality assessment and management. The development of a casing sensor does make this system affordable which requires only acrylic sheets and glue to combine the acrylic sheets. This compartment is quite cost-effective compared to any system that requires robotics to replace the sensor submerged underwater for data collecting.

4. Conclusion

The robust development of a water quality monitoring system based on IoT for Asian sea bass was successfully developed and evaluated using professional devices within 3 months period. The validation process over a long period thus shows a good result where accuracy ranging from 76% to 97% and evaluation of the sensors itself with professional devices able to confirm the quality assurance of the measurement result in the fish tank. Besides, all the data was able to be recorded and processed by using a microcontroller and provided data visualization in Thingspeak, and the Virtuino application was able to develop and function to get the data analyses successfully with the help of the ESP 8266 Wi-Fi module. Real-time results were displayed through these applications with the assistance of an RTC module, providing comprehensive information on the actual water quality conditions in the monitored area.

The improvement in accuracy was based on data collected over five days, and the findings surpassed expectations, outperforming the validation data with R^2 improved from 0.80 to 0.98. Simple linear regression can improve the accuracy of sensor values from an IoT system. An improved accuracy of sensors in water quality monitoring leads to more precise and reliable data. This enhanced accuracy enables a better assessment of the actual conditions in the aquatic environment. With more reliable data at their disposal, aquaculture farmers and environmental managers can make more informed decisions regarding feeding, water treatment, and other aspects of fish farming. This, in turn, contributes to a more accurate and effective management of water quality in aquaculture tanks. Additionally, accurate data is crucial for early detection of any potential issues or anomalies, allowing for prompt corrective action and ultimately leading to better outcomes in fish health and growth.

The design of sensor casings serves a dual purpose which is that it can protect sensors that can't be submerged for extended periods and offers cost-effective maintenance. The use of sensor casings contributes to the affordability of low-cost aquaculture tank systems for WQMS with IoT compared to more complex and expensive alternatives for maintaining these low-cost sensors. Additionally, regular monthly calibration of the sensors and development of casing sensor contributes to prolonging their lifespan.

In summary, the system's broad applicability, enabled through straightforward threshold limit range adjustments, offers a valuable and adaptable tool for enhancing water quality management in diverse aquatic farming practices, contributing to improved yields and sustainability. Although this paper successfully achieved data collection and monitoring, the next phase of research will focus on integrating automatic control and actuation management for water quality monitoring. The study will also consider the use of artificial intelligence applications, which have been widely adopted in the aquaculture sector for monitoring fish behavior, to further expand the scope of the study.

Data availability statement

The data described in this article are openly in the Thingspeak website (ID 1649792) at <https://thingspeak.com/channels/1649792>.

CRedit authorship contribution statement

Nurshahida Azreen Mohd Jais: Writing – review & editing, Writing – original draft, Visualization, Validation, Software, Resources, Project administration, Methodology, Investigation, Funding acquisition, Formal analysis, Data curation, Conceptualization. **Ahmad Fikri Abdullah:** Supervision. **Muhamad Saufi Mohd Kassim:** Supervision. **Murni Marlina Abd Karim:** Supervision. **Abdulsalam M:** Writing – review & editing, Supervision. **Nur 'Atirah Muhadi:** Writing – review & editing, Supervision.

Declaration of competing interest

The authors declare that they have no known competing financial interests or personal relationships that could have appeared to influence the work reported in this paper.

Acknowledgement

Funding

This work was supported by the Department of Higher Education Ministry of Education Malaysia LRGs 2019-1 (5545102), Grant Aquatic Culture System Management through IoT Based Water Quality Database and Monitoring System (9733900) and RECONNECT - Regenerating ECOSystems with Nature-based solutions for hydro-meteorological risk rEduCTion (63801310).

References

- [1] I. Irmawati, M.T. Umar, A. Ambo Ala Husain, A. Citra Malina, N. Nurdin Kadir, A. Alimuddin, Distribution and characteristics of Asian seabass (*Lates calcarifer* Bloch, 1790) in South Sulawesi, in: IOP Conf Ser Earth Environ Sci, IOP Publishing Ltd, 2020, <https://doi.org/10.1088/1755-1315/564/1/012011>.
- [2] B.P. Dasanayaka, Z. Li, S.N. Pramod, Y. Chen, M.U. Khan, H. Lin, A review on food processing and preparation methods for altering fish allergenicity, *Crit. Rev. Food Sci. Nutr.* 62 (2022) 1951–1970, <https://doi.org/10.1080/10408398.2020.1848791>.
- [3] Department of Fisheries Malaysia, Annual Fisheries Statistics 2019, Department of Fisheries Malaysia, 2019. <https://www.dof.gov.my/en/resources/i-extension-en/annual-statistics/>. (Accessed 28 October 2023).
- [4] S. Pasika, S.T. Gandla, Smart water quality monitoring system with cost-effective using IoT, *beliyon* 6 (2020), <https://doi.org/10.1016/j.heliyon.2020.e04096>.
- [5] M.G.B. Palconit, R.S. Concepcion, R.R. Tobias, J. Alejandrino, V.J.D. Almero, A.A. Bandala, R.R.P. Vicerra, E. Sybingco, E.P. Dadios, Development of IoT-based fish tank monitoring system, in: 2021 IEEE 13th International Conference on Humanoid, Nanotechnology, Information Technology, Communication and Control, Environment, and Management, HNICEM 2021, Institute of Electrical and Electronics Engineers Inc., 2021, <https://doi.org/10.1109/HNICEM54116.2021.9731950>.
- [6] C.H. Chen, Y.C. Wu, J.X. Zhang, Y.H. Chen, IoT-based fish Farm water quality monitoring system, *Sensors* 22 (2022), <https://doi.org/10.3390/s22176700>.
- [7] E.T. de Camargo, F.A. Spanhol, J.S. Slongo, M.V.R. da Silva, J. Pazinato, A.V. de Lima Lobo, F.R. Coutinho, F.W.D. Pfrimer, C.A. Lindino, M.S. Oyamada, L. D. Martins, Low-cost water quality sensors for IoT: a Systematic review, *Sensors* 23 (2023), <https://doi.org/10.3390/s23094424>.
- [8] R.A. Bórquez López, L.R. Martínez Cordova, J.C. Gil Nuñez, J.R. Gonzalez Galaviz, J.C. Ibarra Gamez, R.C. Hernandez, Implementation and evaluation of open-source hardware to monitor water quality in precision aquaculture, *Sensors* 20 (2020) 1–14, <https://doi.org/10.3390/s20216112>.
- [9] L. Parra, S. Sendra, L. García, J. Lloret, Design and deployment of low-cost sensors for monitoring the water quality and fish behavior in aquaculture tanks during the feeding process, *Sensors* 18 (2018), <https://doi.org/10.3390/s18030750>.
- [10] S. Fu, W. Xing, J. Wu, J. Chen, S. Liu, Research and design of an intelligent fish tank system, *PLoS One* 18 (2023), <https://doi.org/10.1371/journal.pone.0285105>.
- [11] K. Koritsoglou, V. Christou, G. Ntrisots, G. Tsoumanis, M.G. Tsiouras, N. Giannakeas, A.T. Tzallas, Improving the accuracy of low-cost sensor measurements for freezer automation, *Sensors* 20 (2020) 1–16, <https://doi.org/10.3390/s20216389>.
- [12] S.A.H. Almetwally, M.K. Hassan, M.H. Mourad, Real time internet of things (IoT) based water quality management system, in: *Procedia CIRP*, Elsevier B.V., 2020, pp. 478–485, <https://doi.org/10.1016/j.procir.2020.03.107>.
- [13] A. Jain, A. Malhotra, A. Rohilla, P. Kaushik, Water quality monitoring and management system for Residents, *Int. J. Eng. Adv. Technol.* 9 (2019) 567–570, <https://doi.org/10.35940/ijeat.B3521.129219>.
- [14] Horiba, Galvanic vs Optical Dissolved Oxygen Sensors, Horiba. (n.d.). <https://www.horiba.com/sgp/water-quality/support/technical-tips/electrodes/galvanic-vs-optical-dissolved-oxygen-sensors/>(accessed October 25, 2023).
- [15] Southern Regional Aquaculture Centre (SERAC) University of St. Andrews Scotland, Managing ammonia, *The Fish Site Newsletter*, 2013.
- [16] Fondriest Environment, What Is Conductivity, *Environmental Monitor*, 2011. <https://www.fondriest.com/news/what-is-conductivity.htm>. (Accessed 25 October 2023).
- [17] R. Sallenave, Important water quality parameters in Aquaponics, *Systems Circular* 680 (2016). <http://aces.nmsu.edu/pubs/w/W104.pdf>.
- [18] E. Sotoudeh, I. Naserifard, A. Oujifard, V. Morshedi, Influences of different water temperatures on growth performance, Biochemical body composition, and Hematological Indices of Asian Sea Bass, *Fisheries Sciences and Technology*. 7 (2018) 117–123.
- [19] E. Insivawati, N. Hakimah, M.S. Chudlori, Effect of temperature, pH, and salinity on body weight of Asian Seabass (*Lates calcarifer*) at different stockings, in: IOP Conf Ser Earth Environ Sci, Institute of Physics, 2022, <https://doi.org/10.1088/1755-1315/1036/1/012117>.
- [20] P. Kungvankij, L. Tiro Jr., B. Pudadera Jr., I. Protestas, Biology and Culture of Sea Bass (*Lates calcarifer*), Food and Agriculture Organization, 1986.
- [21] S. Venkatachalam, K. Kandasamy, I. Krishnamoorthy, R. Narayanasamy, Survival and growth of fish (*Lates calcarifer*) under integrated mangrove-aquaculture and open-aquaculture systems, *Aquaculture Reports* 9 (2018) 18–24.
- [22] S.K. Viswanath, C. Yuen, W. Tushar, W.-T. Li, C.-K. Wen, K. Hu, C. Chen, X. Liu, System design of the internet of things for residential smart grid, *IEEE Wireless Commun.* 23 (2016) 90–98.
- [23] D. Nettikadan, S. Raj, Smart community monitoring system using Thingspeak IoT Platform. <http://www.rippublication.com>, 2018.
- [24] R. Singh, M. Baz, A. Gehlot, M. Rashid, M. Khurana, S.V. Akram, S.S. Alshamrani, A.S. Alghamdi, Water quality monitoring and management of building water tank using industrial internet of things, *Sustainability* 13 (2021), <https://doi.org/10.3390/su13158452>.
- [25] J.Y. Lin, H.L. Tsai, W.H. Lyu, An integrated wireless multi-sensor system for monitoring the water quality of aquaculture, *Sensors* 21 (2021), <https://doi.org/10.3390/s21248179>.
- [26] N.J. Kinar, M. Brinkmann, Development of a sensor and measurement platform for water quality observations: design, sensor integration, 3D printing, and open-source hardware. <https://doi.org/10.21203/rs.3.rs-449278/v1>, 2021.
- [27] L.A. Méndez-Barroso, J.A. Rivas-Márquez, I. Sosa-Tinoco, A. Robles-Morúa, Design and implementation of a low-cost multiparameter probe to evaluate the temporal variations of water quality conditions on an estuarine lagoon system, *Environ. Monit. Assess.* 192 (2020) 710, <https://doi.org/10.1007/s10661-020-08677-5>.
- [28] P. Higgins, Comparing the YSI ProDSS vs EXO Water Quality Meters, YSI, 2017. <https://www.ysi.com/ysi-blog/water-blogged-blog/2017/03/comparing-the-ysi-prodss-vs-exo-water-quality-meters#:~:text=The%20ProDSS%20is%20rated%20to,best%20instrument%20for%20your%20use>. (Accessed 25 October 2023).
- [29] YSI, Professional Plus calibration Tips. <https://www.ysi.com/File%20Library/Documents/Tips/YSI-Professional-Plus-Calibration-Tips.pdf>, 2010. (Accessed 25 October 2023).
- [30] J.O. Rawlings, S.G. Pantula, D.A.D. Springer, *Applied Regression Analysis: A Research Tool*, second ed., n.d.
- [31] R.M. Durborow, D.M. Crosby, M.W. Brunson, Ammonia in fish ponds, *J. Fish. Res. Board Can.* 32 (1997) 2379–2383.