

RESEARCH ARTICLE

A potential biomarker of cognitive impairment: The olfactory dysfunction and its genes expression

Jiayi Song^{1,2}, Jiahui Xu¹, Wei Yuan¹, Ruixue Li¹, Hui Guo¹, Hanshu Gao¹, Cuiying Gu¹, Wenjing Feng¹, Yanan Ma^{3,4}, Haiqiang Guo⁵, Zhaoqing Sun⁶ & Liqiang Zheng² 

¹School of Public Health, China Medical University, Shenyang, 110122, China

²Ministry of Education-Shanghai Key Laboratory of Children's Environmental Health, School of Public Health, Shanghai Jiao Tong University School of Medicine, Shanghai, 200025, China

³Department of Biostatistics and Epidemiology, School of Public Health, China Medical University, No.77 Puhe Road, Shenyang, Liaoning Province, 110122, China

⁴Institute of Health Sciences, China Medical University, No.77 Puhe Road, Shenyang, Liaoning Province, 110122, China

⁵Department of Health Statistics, China Medical University, Shenyang, 110122, China

⁶Department of Cardiology, Shengjing Hospital of China Medical University, Shenyang, 110004, P. R. China

Correspondence

Liqiang Zheng, Ministry of Education-Shanghai Key Laboratory of Children's Environmental Health, School of Public Health, Shanghai Jiao Tong University School of Medicine, Shanghai, 200025, China. Tel: +86-21-63846590; Fax: +86-21-63846590; E-mail: liqiangzheng@126.com Zhaoqing Sun, Department of Cardiology, Shengjing Hospital of China Medical University, Shenyang 110004, China. Tel: +86-24-83282688; Fax: +86-24-83282346; E-mail: sunzhaoqing@vip.163.com

Funding Information

This research was supported by funds from the National Nature Science Foundation of China [No. 82073645].

Received: 6 July 2022; Revised: 9 September 2022; Accepted: 1 October 2022

Annals of Clinical and Translational Neurology 2022; 9(12): 1884–1897

doi: 10.1002/acn3.51680

#Joint corresponding authors: Liqiang Zheng, Zhaoqing Sun.

Introduction

The ability to smell is a complicated procedure involving the nose and brain. Olfactory nerves are present in a specialized lining at the top of the nasal cavity called the olfactory epithelium. The prevalence of smell disorders among older adults, most of whom are unaware of the olfactory impairment, is high and increases with age.¹

Abstract

Objective: Accumulation evidence has reported that olfactory impairment may be an essential clinical marker and predictor of mild cognitive impairment or Alzheimer's disease. **Method:** Participants were enrolled in the population-based, prospective study in Fuxin county, Liaoning province, China between 2019 and 2021. An inverse probability weighting logistic regression and mixed-effect models were performed to explore the association between dysosmia and cognition and rate of change in cognition, respectively. Besides, we utilized the Robust Rank Aggregation method to integrated three eligible datasets from the Gene Expression Omnibus to identify differential expressed genes. **Results:** A total of 4695 participants were enrolled and 4221 of those were eligible for our cross-sectional study. The mean (SD) age was 59.93(9.78) years, 64.8% were men. Over a 2-year follow-up, of the 2088 participants who completed follow-up, 1559 participants were eligible for our longitude cohort study. We observed an association between dysosmia and an increased risk of cognitive impairment (OR, 0.47, [95% CI, 0.35–0.64]; $p < 0.001$). The OR (95% CI) for cognition in females with dysosmia was higher than (OR, 0.73[0.51, 1.05], $p = .007$) that for males with dysosmia (OR, 0.25[0.15, 0.42], $p < 0.001$; P for interaction < 0.001). Dysosmia was also associated with more rapid decline in calculation ability ($p < 0.001$). Besides, several DEGs were identified, which are mainly associated with olfactory transduction, detection of chemical stimulus involved in sensory perception of smell, sensory perception of smell, olfactory receptor activity and odorant binding. **Interpretation:** These findings proved novel insight into identifying olfactory dysfunction as potential biomarker for diagnosis of cognitive impairment.

Severe olfactory impairment has a strong negative effect on the quality of daily life.² In addition to congenital and idiopathic Anosmia, olfactory deficits are associated with a number of diseases, especially neurodegenerative diseases, such as Alzheimer's disease (AD) and Parkinson's disease (PD).³ Consistent with this, several clinical-based, case-control, cross-sectional studies have demonstrated associations of olfactory impairments (especially

impairments identification dysfunction) with cognitive decline, mild cognitive impairment (MCI), or Alzheimer's disease, which are capable of reflecting the onset of cognitive decline, MCI and AD in cognitively normal adults.⁴⁻⁷ Besides, several studies have demonstrated that olfactory impairment is associated with some diseases with neurological complications, such as obstructive sleep apnea, depression and so on.⁸⁻¹⁰ There are several studies demonstrating that the neuropathologic changes olfactory disorders in neurodegenerative diseases may be related to the olfactory epithelium, olfactory bulb/tract, primary olfactory and their secondary targets.¹¹ Although several longitudinal studies on olfactory dysfunction and progression from MCI to dementia, fewer on the association with cognitive function and MCI.¹² These studies on olfactory function and MCI and cognitive function have often been conducted in cross-sectional¹³ or clinical-based studies and in studies of small sample size, which are mostly conducted in other countries rather than China. To our knowledge, few longitude cohort studies have investigated the association between olfactory function with cognitive function in a large population-based cohort. Thus, we conducted a study on the association of olfactory impairment with cognitive impairment in a large, prospective, population-based study in rural China.

In addition, the mechanism of olfactory recognition impairment in population with cognitive impairment, particularly AD patients, is yet unclear. Exploring and confirming the mechanism of olfactory impairment in AD can provide more sufficient evidence to consider olfactory dysfunction as a biomarker of the early stage of AD.⁶ In this current study, we analyzed three independent gene expression datasets from the Gene Expression Omnibus (GEO) database and merger the analysis results using the Robust rank aggregation (RRA) to identify significant differentially expressed genes (DEGs) associated with olfactory function. Gene Ontology (GO) enrichment and Kyoto Encyclopedia of Genes and Genomes (KEGG) pathway analyses were further used to confirm the odorant identification relevant functions of these genes. Eventually, these differentially expressed olfactory receptor genes were analyzed for their methylation levels in AD samples and CN samples using another GEO dataset.

Methods

Study design and participants

The study was based on a large-scale epidemiological survey conducted in rural areas of Fuxin county, Liaoning province, China. During June 2019 and August 2019, a questionnaire survey was conducted on the general population. In order to ensure the representation of the

sample, the research area was divided into the eastern part, the southern part and the northern part. According to the demographic characteristics, two townships, one township and one township were selected from the southern part, northern part and southern part, respectively. According to geographic locations, 33 villages were selected from these four townships. Participants were eligible if: (1) they were 35 years of age or older; (2) they had stayed in the study area for at least 5 years; (3) they were willing to sign a consent form. After excluding participants based on the following reasons: (1) pregnant; (2) developing severe liver and renal failure; (3) being unwilling to participate in this study, finally, 4689 participants were recruited as study population. During June 2021 and August 2021, the second wave survey was conducted. Finally, 6083 participants were available after two surveys, among them, 2601 and 1394 participants completed only the first survey and the second survey, respectively, with 2088 completing both these investigations. Data on demographic and other factors, including demographic features, lifestyle, the history of disease and blood biochemical index were recorded by interview. Written informed consent was obtained from all participants. All protocols were approved by the human experimentation committee of China medical university ([2018]083).

Assessment of olfactory dysfunction

The olfactory function was assessed by a validated questionnaire, over at least three months. In this study, we used the following questions in the main analyses: "Do you have any problems with your sense of smell, such as not being able to smell things or things not smelling the way they are supposed to for ≥ 3 months. Those who answered "yes" were considered to have smell dysfunction."¹⁴

Assessment of cognitive function

In the 2019 baseline survey and the 2021 follow-up survey, cognitive function was assessed by the use of Montreal Cognitive Assessment-Basic for Chinese (MoCA-BC). The MoCA-BC, consisting of nine cognitive domains including executive function, language, orientation, calculation, conceptual thinking, memory, visual perception, attention, and concentration, is the Chinese version of MoCA-B, used to screen the MCI of the elderly in China with different education levels, which has been proved to be more reliable, simple and effective. The highest total score is 30 points.¹⁵ In this study, as there is no clear established cutoff value to define mild cognitive impairment, the cognitive score was then categorized quartiles and binary digits based on its own distribution. The

higher the cognitive score, the better the cognitive function.

Covariates measurement

Sociodemographic covariates for this study included age (at survey response), sex, ethnicity, level of education and marital status. Physical measurements for this study including weight, height and blood pressure were collected by standardized methods. Blood pressure was measured with the corrected HEM-8102A/K electronic sphygmomanometer at the same level as the heart on the right arm three times with more than 1 min intervals after 5 min seated rest. Besides, before the measurements, participants were asked to empty their bladder and refrain from smoking, drinking alcohol, drinking coffee and strenuous physical activity within 30 min. Finally, an average of three measurements of every participant was used for analysis. Then body mass index (BMI) was calculated as weight in kilograms divided by the square of the height in meter. Individual living habits (such as smoking status, alcohol consumption) and medical history (such as hypertension, stroke, diabetes, dyslipidemia) were summarized from several questions respectively. Smoking status was divided into past smokers, current smokers, and non-smokers. Among them, a current smoker was a participant who smoked at least one cigarette a day for more than 1 month. In addition, alcohol consumption was divided into past drinkers, current drinkers, and non-drinkers. Among them, those who drank at least twice a week for more than 6 months were considered current drinkers. Hypertension was defined based on the seventh report of the Joint National Committee for the diagnosis, evaluation, and treatment of high blood pressure (JNC-7).¹⁶ Hypertension (HTN) was defined as an SBP/DBP \geq 140/90 mmHg. Diabetes mellitus was defined as fasting blood glucose (FBG) of at least 7.1 mmol/L, and/or self-reported diabetes diagnosis, and/or taking measures to control blood glucose.¹⁷ Fasting blood samples were collected in the morning from participants who fasted for at least 8 h and analyzed using a Roche Cobas 8000C701 automatic biochemical analyzer in an accredited central laboratory. TG was determined by colorimetry, TC, LDL-C, and HDL-C were determined by enzyme colorimetry. All laboratory devices have been calibrated and blood samples have been randomly coded and blind tested to reduce systematic error and variability. Dyslipidemia was defined as total cholesterol (TC) of at least 6.2 mmol/L, and/or triacylglycerol (TG) of at least 2.3 mmol/L, and/or high-density lipoprotein (HDL) of at most 1.0 mmol/L, and/or low-density lipoprotein (LDL) of at most 4.1 mmol/L.

Statistical analysis

Cognitive function was characterized as the continuous or categorical MoCA-BC score. A multivariate linear regression model and multivariate logistic regression model were used for the case-weighted and inverse probability-weighted analyses to determine the effect of olfactory function on cognitive function. Using the same baseline characteristics for the propensity score calculation allowed case-weight estimation with a logistic regression model to predict the inverse probability of developing olfactory dysfunction. Participants with dysosmia were weighted by the inverse of the propensity score and those without dysosmia were weighted by the inverse of (1-propensity score).¹⁸ These case weights balanced the cohorts for an inverse probability-weighted analysis that included all participants with available data.¹⁹ Three sets of covariates were used in the cognitive function analyses. Forward stepwise regression was then used to determine the final model and covariates in the final model included age, sex, ethnic, education, marital status, BMI, smoking status, alcohol consumption, diabetes, dyslipidemia. In addition to the aforementioned analysis, stratified analysis for cognitive function of the age, sex, marital status, and smoking status were performed and possible interactions between olfactory function* sex, olfactory function* age, olfactory function* marital status, and olfactory function* smoking status were tested in the adjusted final model.

Categorical variables were reported as frequencies with percentages, and non-normally distributed continuous variables were reported as medians with interquartile ranges. Skewed distribution variables and categorical variables were compared using the Kruskal–Walls test and chi-square test, respectively.

Mixed-effects models were used to test the relationship of olfactory function to baseline level and rate of change in cognitive function and different domains of cognition during follow-up. Each model included terms of time (in years since baseline) and for olfactory function and the interaction of olfactory function with time. The term for olfactory function indicates the association of the olfactory function with the level of cognition at baseline, and the interaction tests the relation of olfactory function to rate of change in cognition.⁴ All the analyses were performed using R software version 4.1.1, with a significant threshold of 2-tailed $p < 0.05$.

Data collection

All eligible microarray datasets were searched using the keyword “Alzheimer” and were downloaded from the GEO database. Datasets were included if they satisfied

the following criteria: (1) were from humans; (2) included expression data from the temporal cortex of both AD samples and cognitive normal (CN) samples; (3) the number of rows in each platform was >30,000; (4) the olfactory receptor genes detected >300; and there were no repeated samples among datasets. Finally, three datasets (GSE118553, GSE122063, GSE132903) from the temporal cortex of AD and CN samples; one DNA methylation dataset (GSE109887) from temporal cortex and blood of AD samples and age-matched controls were selected. Main characteristics for these datasets, including GEO accession ID, dataset country, sample numbers, platform ID, and number of genes in each platform, as well as usage in the current study is illustrated (Table 1). Series matrix files of these datasets and their corresponding platform files were downloaded for the current analysis.

Identification of differentially expressed olfactory receptor genes

GeneCards (<https://www.genecards.org/>) were used to screen for genes associated with olfactory function (Table S1). The GEOquery package was utilized to parse GEO data into R data structures that can be used by other R packages and the R package “limma” was utilized to normalize the data and find differentially expressed genes (DEGs). Robust rank aggregation (RRA) was then used to integrate the results of these three datasets to identify the most significant differentially expressed genes associated with olfactory function. Genes with $P < 0.05$ were considered as significant differentially expressed genes in the RRA analysis.

Functional enrichment analysis of DEGs

In order to elucidate the enrichment of DEGs associated with olfactory function in biological process and signaling pathway, Kyoto Encyclopedia of Genes and Genomes (KEGG) analysis, and Gene Ontology (GO) enrichment analysis were conducted by KEGG (<https://www.kegg.jp/>) and R packages “clusterProfiler”.

Methylation analysis

Methylation analysis was performed by EWAS Data Hub (<https://bigd.big.ac.cn/ewas/datahub>) and GEO2R analysis with adjusted $P < 0.05$ as cutoff values to compare methylation levels of significant DEGs between AD samples and control samples.

Result

Baseline characteristics

A total of 4695 participants were enrolled and 4221 of those were eligible for our cross-sectional study. Baseline characteristics were stratified by whether developing dysosmia and whether adjusting by weighting approaches (Table 2). At baseline, participants with dysosmia were different from those without dysosmia in terms of age, sex, ethnicity, education and marital status. After propensity score weighting, there were no significant differences in the baseline variables used for calculation. Additionally, of the 2088 participants who completed follow-up, 1559 participants were eligible for mixed-effects models analysis.

Impaired olfactory function and cognitive function

Cognitive function was positively associated with olfactory function (Table 3). Olfactory dysfunction was associated with worse cognitive function (adjusted OR 0.47[95% CI (0.35, 0.64)], $p < 0.001$). Compared with the lower MoCA-BC binary digits (binary digits 1, worst scores), OR (95% CI) was 0.73 (0.66, 0.81) for binary digits 2 ($p < 0.001$). Compared with the lowest MoCA-BC quartile (quartile [Q] 1, worst scores), OR (95% CI) was 0.90 (0.79–1.02) for Q₂ ($p = 0.11$); 0.72 (0.64, 0.82) for Q₃ ($p < 0.001$); 0.66 (0.58, 0.76) for Q₄ ($p < 0.001$) (best scores). There was no significant interaction of smell with age (Fig. 1). However, the OR (95% CI) for cognition in women with dysosmia was higher than (OR, 0.73[0.51, 1.05], $p = 0.07$) that for men with dysosmia (OR, 0.25

Table 1. Main characteristics of the included datasets.

Tissue	Dataset ID	Country	No. of samples	GPL ID	No. of rows per platform
Temporal cortex	GSE118553	United Kingdom	52 AD 31CN	GPL10558	48,107
Temporal cortex	GSE122063	United states	28 AD 22CN	GPL16699	62,976
Temporal cortex	GSE132903	United states	98 AD 98CN	GPL10558	48,107
Temporal cortex	GSE109887	Germany	46 AD 32CN	GPL10904	34,695

Abbreviations: GSE, Gene Expression Omnibus Series; GPL, Gene Expression Omnibus Platform; AD, Alzheimer's disease samples; CN, cognitive normal samples.

Table 2. Demographic and Baseline Information of Participants by Olfactory function at baseline.

Characteristics	Overall			<i>p</i> value	Inverse probability-weighted cohort		<i>p</i> value
	Total (<i>N</i> = 4221)	Dysosmia (<i>N</i> = 315)	No anosmia (<i>N</i> = 3906)		Dysosmia (<i>N</i> = 4166.14)	No anosmia (<i>N</i> = 4221.21)	
Age, y	59.93 ± 9.78	60.93 ± 8.99	58.77 ± 9.83	<0.001	59.21 ± 9.15)	58.93 ± 9.84	0.633
Male, No. (%)	2736 (64.8)	221 (70.2)	2515 (64.4)	0.045	2696.4 (64.7)	2735.9 (64.8)	0.979
Ethnicity, No. (%)				0.021			0.550
The Han nationality	2767 (65.6)	193 (61.3)	2574 (65.9)		2685.3 (64.5)	2766.6 (65.5)	
The Mongol nationality	1285 (30.4)	115(36.5)	1170 (30.0)		1360.3 (32.7)	1285.7 (30.5)	
Other ethnic groups	169 (4.0)	7 (2.2)	162 (4.1)		120.6 (2.9)	168.9 (4.0)	
Education, No. (%)				0.001			0.780
Primary school or below	1814 (43.0)	165 (52.4)	1649 (42.2)		1858.7 (44.6)	1814.6 (43.0)	
Junior high school	1818 (43.1)	105 (33.3)	1713 (43.9)		1703.7 (40.9)	1817.6 (43.1)	
Senior high school or above	589 (14.0)	45 (14.3)	544 (13.9)		603.7 (14.5)	589.0 (14.0)	
Living alone, No. (%)	499 (11.8)	61 (19.4)	438 (11.2)	<0.001	500.2 (12.0)	499.1 (11.8)	0.912
Smoking status, No. (%)				0.058			0.953
Current smokers	1164 (27.6)	103 (32.7)	1061 (27.2)		1167.2 (28.0)	1163.9 (27.6)	
Past smokers	348 (8.2)	19 (6.0)	329 (8.4)		322.4 (7.7)	348.0 (8.2)	
Non-smokers	2709 (64.2)	193 (61.3)	2516 (64.4)		2676.5 (64.2)	2709.4 (64.2)	
Alcohol consumption, No. (%)				0.615			0.973
Current drinkers	912 (21.6)	67 (21.3)	845 (21.6)		924.8 (22.2)	912.3 (21.6)	
Past drinkers	353 (8.4)	31 (9.8)	322 (8.2)		347.2 (8.3)	352.8 (8.4)	
Non-drinkers	2956 (70.0)	217 (68.9)	2739 (70.1)		2894.2 (69.5)	2956.1 (70.0)	
BMI, kg/m ²	24.76 ± 3.70	24.79 ± 3.69	24.45 ± 3.81	0.123	24.68 (3.78)	24.77 (3.69)	0.712
Hypertension, No. (%)	1716 (40.7)	128 (40.6)	1588 (40.7)	1.000	1726.3 (41.4)	1716.6 (40.7)	0.802
Diabetes, No. (%)	517 (12.2)	34 (10.8)	483 (12.4)	0.466	465.0 (11.2)	516.9 (12.2)	0.593
Dyslipidemia, No. (%)	1826 (43.3)	122(38.7)	1704 (43.6)	0.104	1825.0 (43.8)	1826.3 (43.3)	0.863

Table 3. Cross-sectional Association of olfactory function with cognitive score.^a

MoCA-B score ^b	Overall		Inverse Probability-Weighted	
	OR (95% CI)	<i>p</i> value	OR (95% CI)	<i>p</i> value
Continuous	0.49 (0.28, 0.87)	0.01	0.47 (0.35, 0.64)	<0.001
Binary digits (cognitive score range)				
(1, 20)	-	-	-	-
(20, 30)	0.73 (0.56, 0.94)	0.02	0.73 (0.66, 0.81)	<0.001
Quartiles (cognitive score range)				
(1, 16)	-	-	-	-
(16, 20)	0.94 (0.68, 1.30)	0.70	0.90 (0.79, 1.02)	0.11
(20, 24)	0.73 (0.52, 1.01)	0.06	0.72 (0.64, 0.82)	<0.001
(24, 30)	0.69 (0.48, 0.99)	0.05	0.66 (0.58, 0.76)	<0.001

Abbreviation: OR, odds ratio.

^aModel is adjusted for age, sex, ethnics, education, marital status, BMI, smoking status, alcohol consumption, diabetes, dyslipidemia.

^bThe MoCA-B score here represents the cognitive function. The higher the cognitive score, the better the cognitive function.

[0.15, 0.42], *p* < 0.001; *p* for interaction <0.001). The OR (95% CI) for cognition in participants living together is higher than (OR, 0.60[0.44, 0.83], *p* = 0.003) that for participants living alone (OR, 0.11[0.04, 0.29], *p* < 0.001; *p*

for interaction <0.001). The OR (95% CI) for cognition in current smokers is higher than (OR, 0.42[0.23, 0.75], *p* = 0.01) that for past smokers (OR, 0.12[0.04, 0.37], *p* < 0.001, *p* for interaction = 0.03).

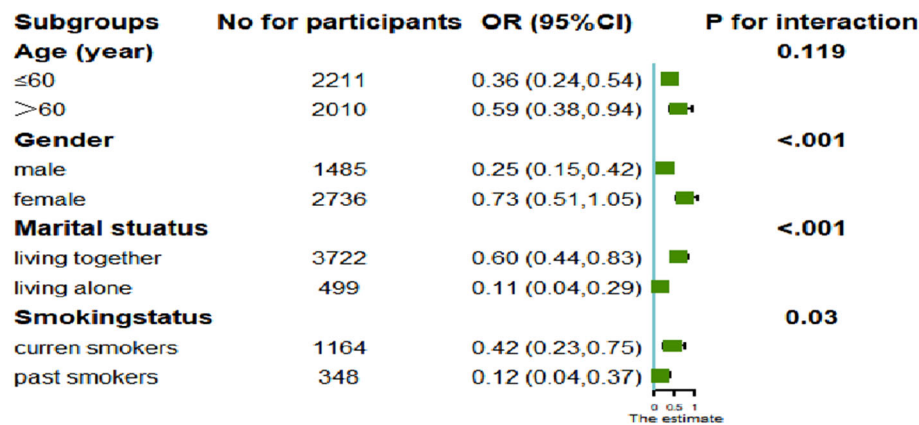

Figure 1. Subgroup analyses of the associations between olfactory function and cognitive function according to possible influencing factor.

Impaired olfactory function and changes in cognition

We constructed a mixed-effects model (Table 4) to characterize cognitive decline in participants and to

Table 4. Relationship of olfactory function to baseline level of and rate of decline in different domains of cognition.

Cognitive outcome and model term	Estimate Mean ± SE	p value
Cognitive function		
Olfactory dysfunction	-1.63 ± 0.36	<0.01
Olfactory dysfunction × time	0.97 ± 0.54	0.07
Excutive function		
Olfactory dysfunction	-0.02 ± 0.03	0.62
Olfactory dysfunction × time	0.06 ± 0.05	0.25
Fluency		
Olfactory dysfunction	-0.19 ± 0.05	<0.01
Olfactory dysfunction × time	0.13 ± 0.08	0.10
Oritention		
Olfactory dysfunction	-0.16 ± 0.08	0.03
Olfactory dysfunction × time	0.04 ± 0.12	0.72
Calculation ability		
Olfactory dysfunction	-0.36 ± 0.09	<0.01
Olfactory dysfunction × time	0.49 ± 0.14	<0.01
Abstraction		
Olfactory dysfunction	-0.26 ± 0.08	<0.01
Olfactory dysfunction × time	0.22 ± 0.13	0.08
Delay recall		
Olfactory dysfunction	-0.34 ± 0.13	0.01
Olfactory dysfunction × time	-0.02 ± 0.20	0.93
Visuospatial skills		
Olfactory dysfunction	-0.15 ± 0.07	0.04
Olfactory dysfunction × time	0.06 ± 0.11	0.60
Naming ability		
Olfactory dysfunction	-0.04 ± 0.06	0.44
Olfactory dysfunction × time	-0.14 ± 0.09	0.11

Estimate from mixed-effects models adjusted for age, sex, education.

demonstrate the hypothesis that olfactory dysfunction is related to more rapid cognitive decline. In this analysis, olfactory dysfunction was negatively associated with baseline level of cognitive function (mean ± SE estimate, -1.63 ± 0.36; $p < 0.01$). However, there was no significant difference to demonstrate that olfactory dysfunction was associated with more rapid decline in cognition (mean ± SE estimate, 0.97 ± 0.54; $p = 0.07$). To demonstrate if olfactory dysfunction was associated with decline in cognitive domains. We repeated the analysis in specific cognitive domains. In these analyses, olfactory dysfunction was associated with lower function at baseline in several cognitive domains, including fluency, orientation, calculating ability, abstraction and visuospatial skills, and with more rapid decline only in calculation ability.

Identification of significant differentially expressed olfactory receptor genes by the RRA method

The significant DEGs of three datasets GSE118553, GSE122063, GSE132903, respectively, were identified and shown in volcano plots (Fig. 2). Based on the results of RRA analysis, significant differentially expressed genes associated with olfactory function were identified ($p < 0.05$) (Table S2 and Fig. S1).

Functional enrichment analysis of DEGs

All DEGs were utilized to perform KEGG and GO analyses (Fig. 3). The top of these terms based on their adjusted P -value are also displayed in chord plots (Figs. 4–6). For KEGG pathway analysis, DEGs were mostly enriched in olfactory transduction (Fig. 3C,D). We found several enrichments associated with olfactory function for GO analysis, including sensory perception of

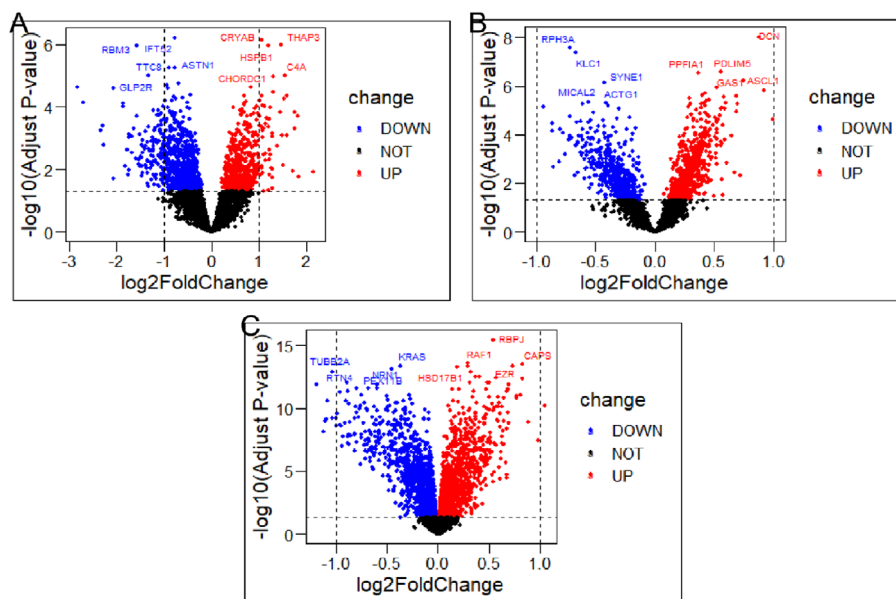

Figure 2. Significant differentially expressed genes associated with olfactory function of three datasets. (A) GSE122063. (B) GSE118553. (C) GSE132903.

smell and detection of chemical stimulus involved in sensory perception of smell (Fig. 3A,B). The top biological process terms associated with olfactory function for GO analysis were sensory perception of smell and detection of chemical stimulus involved in sensory perception of smell. The top molecular function term for GO analysis associated with olfactory function was olfactory receptor activity (Fig. S2). What's more, some top biological process GO terms (Fig. 4), cellular component GO terms (Fig. 5), and molecular function GO terms (Fig. 6) were primarily associated with these genes. In addition, we conducted enrichment analyses in up-regulation genes and down-regulated genes independently and discovered that up-regulated genes were mostly enriched in pathways associated with olfactory function, including detection of chemical stimulus involved in sensory perception of smell, sensory perception of smell, olfactory receptor activity and odorant binding (Fig. S3). The KEGG pathway of DEGs associated with olfactory function is demonstrated (Fig. 7).

Association between methylation and expression of significant differentially expressed genes

We explored the association between these up-regulated olfactory receptor genes as well as down-regulated olfactory receptor genes with their methylation status to explore potential mechanisms of abnormal olfactory receptor genes expression in AD patients' brain tissues. However, no significant results were obtained.

Discussion

To our knowledge, this is the first epidemiological study that reports the relationship between olfactory function and cognitive function in Chinese rural areas. In this cohort, impaired olfaction was associated with poor cognition and with greater decline in different domains of cognitive performance during follow-up. In addition, we found that there was significant interaction of olfaction with sex. Compared with males, females with olfactory impairment have a higher risk of cognitive impairment.

A cross-sectional study found that hyposmia was associated with worse performance on memory and executive function²⁰ and in another study with a Chinese sample, impaired olfaction was associated with MCI.²¹ In other longitudinal studies, impaired olfactory function was associated with declines in verbal, visual memory,²² executive function, language and global cognitive.²³ In this study, the results from mixed models suggest that impaired olfaction is associated with worse cognitive performance and predicts decline in cognitive performance in the calculation domain, which suggests that brain regions mediating performance in the calculation domain may be involved early in the disease process. Although several previous studies have reported olfactory impaired in patients with cognitive mild impairment and Alzheimer's Disease^{24–26} and poor olfactory function is an independent factor associated with cognitive decline, after adjusting for possible confounding factors,¹³ these studies were limited conducted mainly in other countries or a

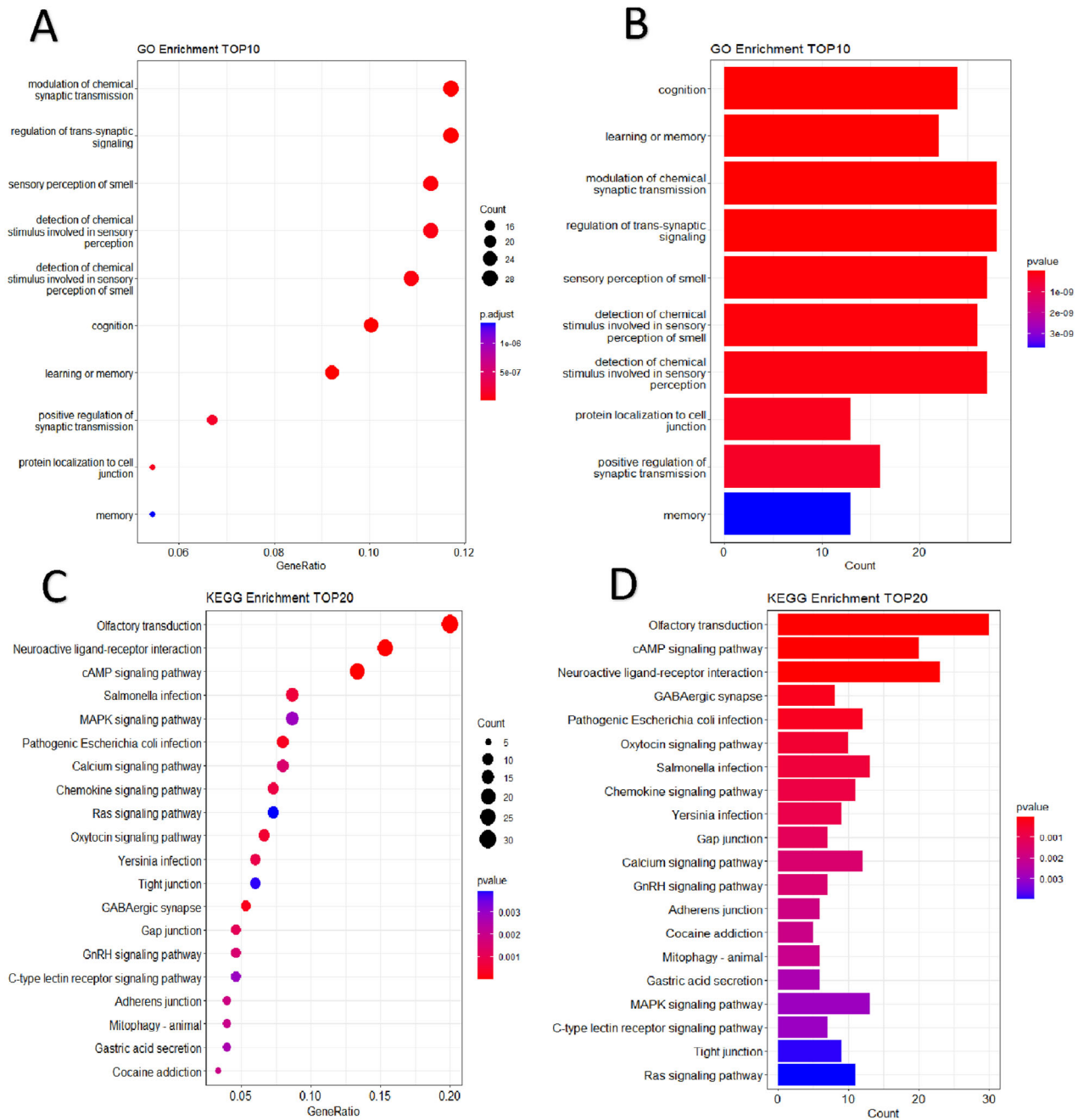

Figure 3. Gene Ontology (GO) and Kyoto Encyclopedia of Genes and Genomes (KEGG) analyses of all differentially expressed genes associated with olfactory function. (A) dot plot of GO analysis. (B) bar plot of GO analysis. (C) dot plot of KEGG analysis. (D) bar plot of KEGG analysis.

smaller number of participants including patients. Besides, to the best of our knowledge, few studies have focused on the relationship of olfactory function with cognitive function in different sex groups. We performed stratified analysis and interaction analysis. The result demonstrated that the positive relationship between olfactory function and cognitive function existed in both

groups. In addition, compared with females, males with olfactory deficits have a larger risk of developing MCI. This may be related to the protective effect of female estrogens. Previous studies have found that females had better olfactory identification ability than males. Estrogens have repeatedly shown to influence various olfactory mediated social behaviors, which is related to prefrontal

GO-Biological Process

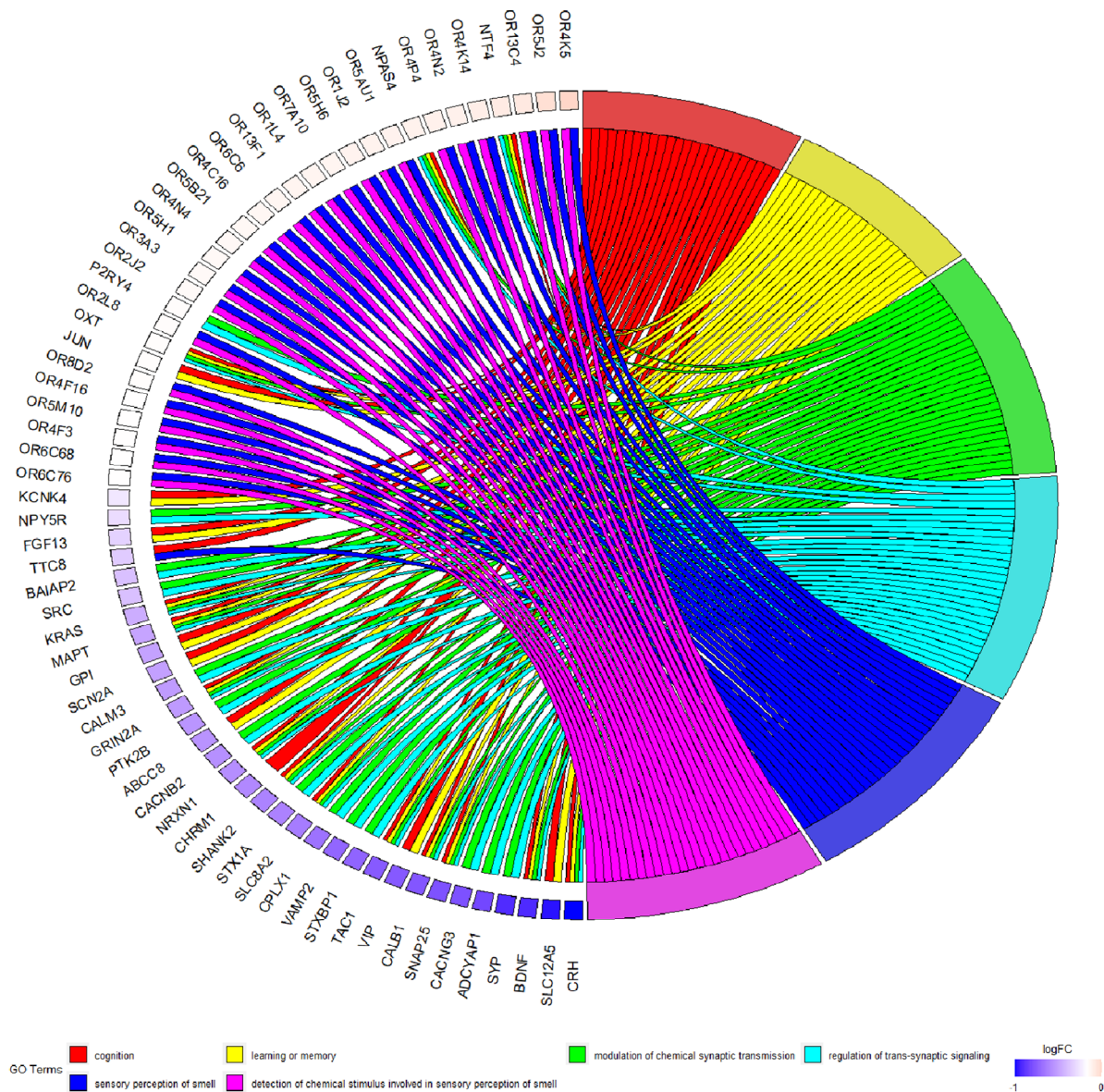

Figure 4. GO analysis differential expressed genes. Chord plot depicting the relationship between genes and GO terms of biological process.

cortex and hippocampus.²⁷ Furthermore, through playing effects on brain regions including the prefrontal cortex and hippocampus, estrogen can facilitate higher cognitive function.²⁸ Therefore, we assume that at the beginning of the disease, under the effect of hormone, the slight olfactory relevant pathological change does not cause obvious clinical symptoms. Once the females appear to detectable olfactory dysfunction, the possibility of the existence of cognitive impairment is greatly improved, which suggests that in clinical practice, applying olfactory dysfunction for

early marker of cognitive impairment, sex differences should be taken into consideration.

In addition, our study is the first to utilize RRA to explore the relationship between genes associated with olfactory function and AD as well as identify DEGs. Based on the results of GO and KEGG pathway analyses, these differentially expressed olfactory receptor genes are closely associated with olfactory transduction, detection of chemical stimulus involved in sensory perception of smell, sensory perception of smell, olfactory receptor activity, and

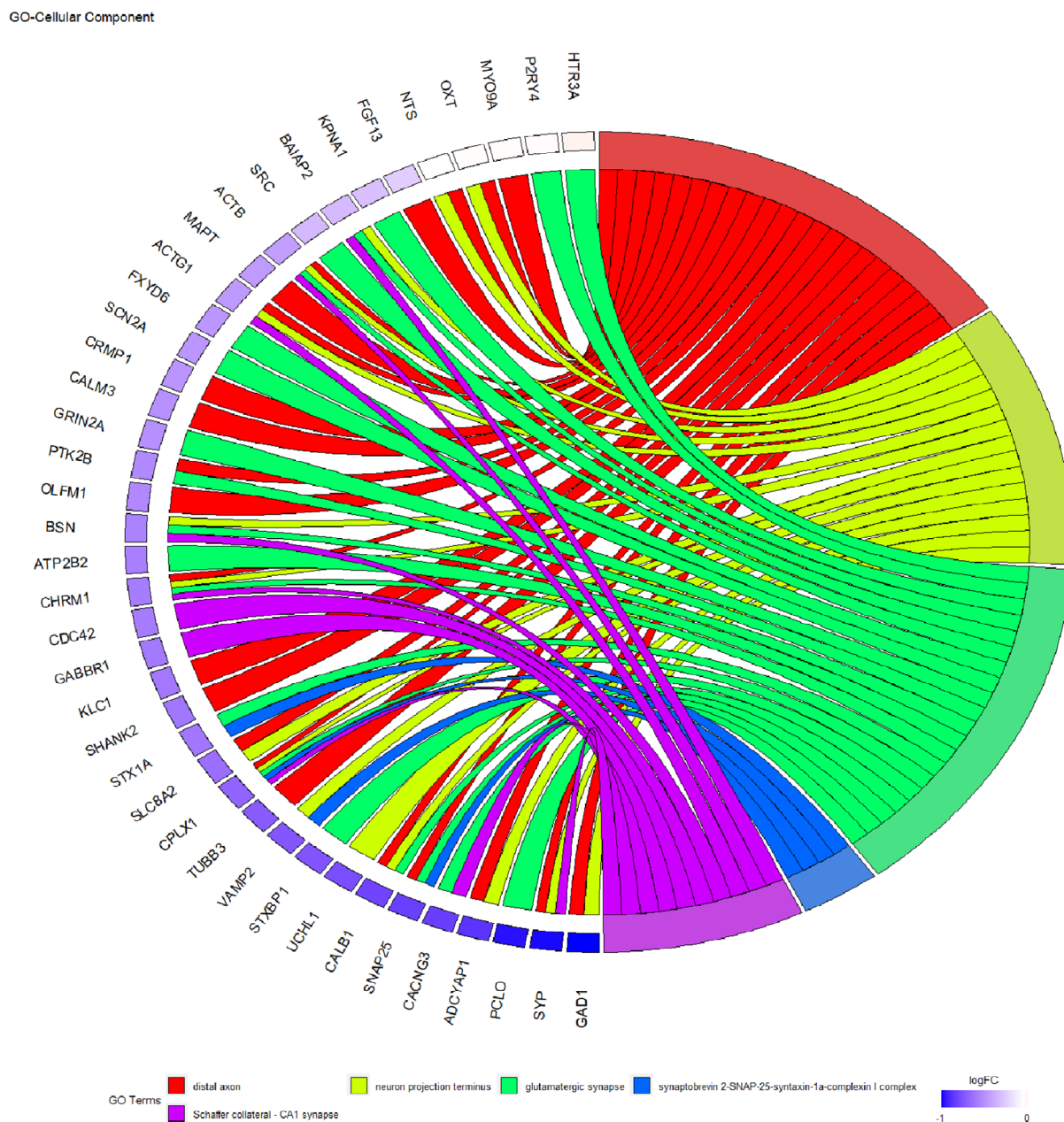

Figure 5. GO analysis differential expressed genes. Chord plot depicting the relationship between genes and GO terms of cellular component.

odorant binding. The expression of type III adenylyl cyclase (AC) is down-regulated in Alzheimer’s disease patients, reducing intracellular cAMP levels, which alters the function of olfactory-specific cyclic nucleotide gated ion channel (CNG), and inhibits the depolarization of olfactory receptor neurons (ORNs) and finally affects the olfactory function. However, no significant results of DNA methylation were found, which indicated that DNA methylation is less likely to explain olfactory dysfunction in cognitive impairment population.

In addition to the general population, olfactory impairment is also an independent MCI risk factor in some special populations, including populations with diabetes, older people with HIV (PWH). There is a study having found that the risk of MCI in type 2 diabetes mellitus (T2DM) patients with olfactory impairment is 4.61 times higher than that in T2DM patients without olfactory impairment. Another study suggests that olfactory dysfunction can help to distinguish between aMCI/Alzheimer’s disease and HIV-associated neurocognitive

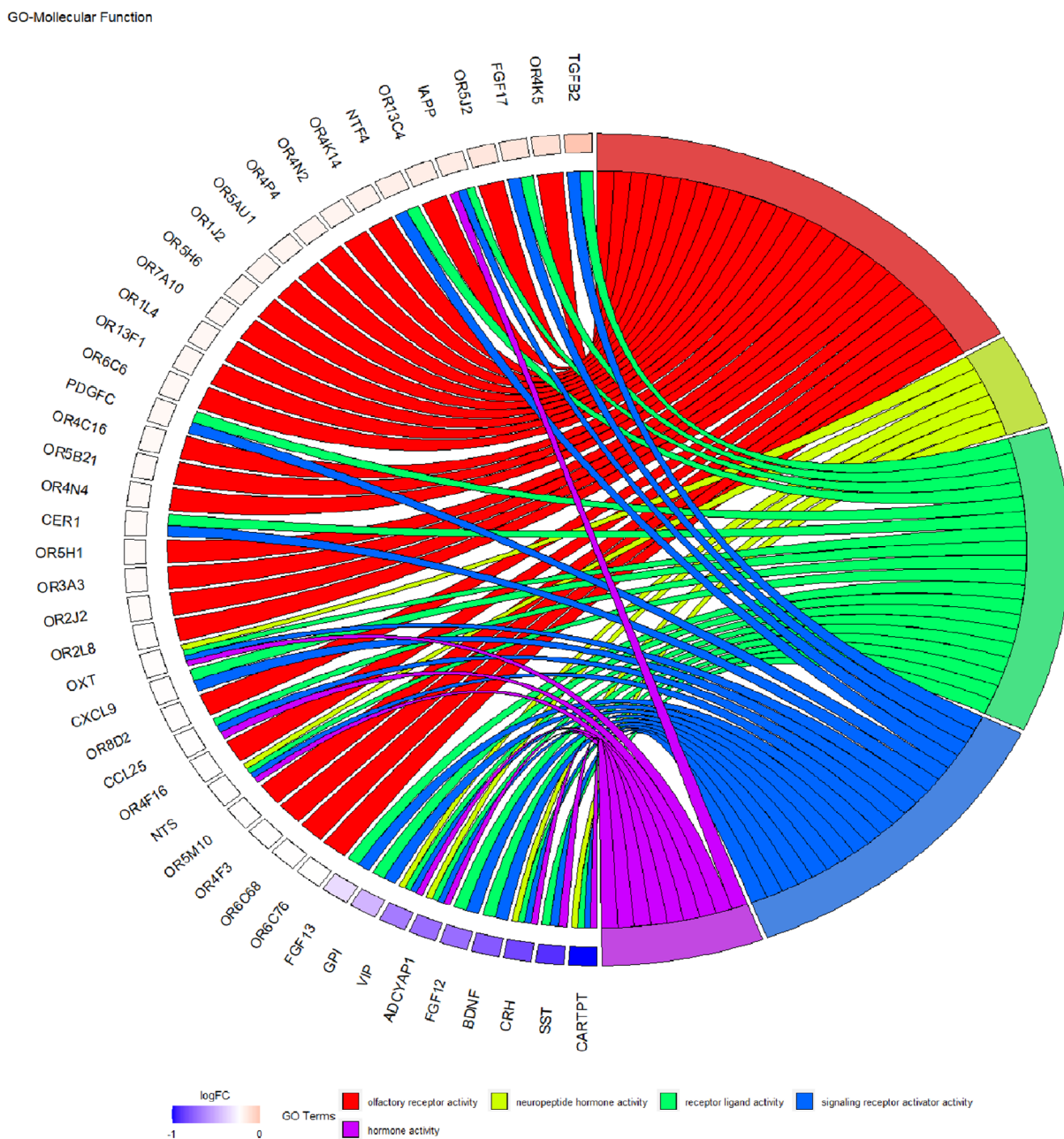

Figure 6. GO analysis differential expressed genes. Chord plot depicting the relationship between genes and GO terms of molecular function.

disorders (HAND) among PWH.²⁹ Furthermore, odor identification impairment can indicate future cognitive decline in elderly carriers of the ApoE-ε4 allele.³⁰ At the genetic level, a study suggests that the olfactory mucosal miR-206 level may be an excellent biomarker for the diagnosis of early AD.³¹

Potential mechanisms for the present findings may relate to neurodegenerative changes of the olfactory bulb and tracts and central brain regions involving cognitive

function and olfactory function.³² Neurofibrillary tangles, markers of AD pathology, have been observed in the olfactory bulb prior to other symptoms related to AD dementia, which demonstrates that olfactory deficits may be early markers.^{32–34} Besides, another mechanism hypothesizes that decline in levels of Choline acetyl transferase and dopamine in the olfactory tubercle and other brain regions as well as decreased norepinephrine related to damage in the locus coeruleus, an important source of

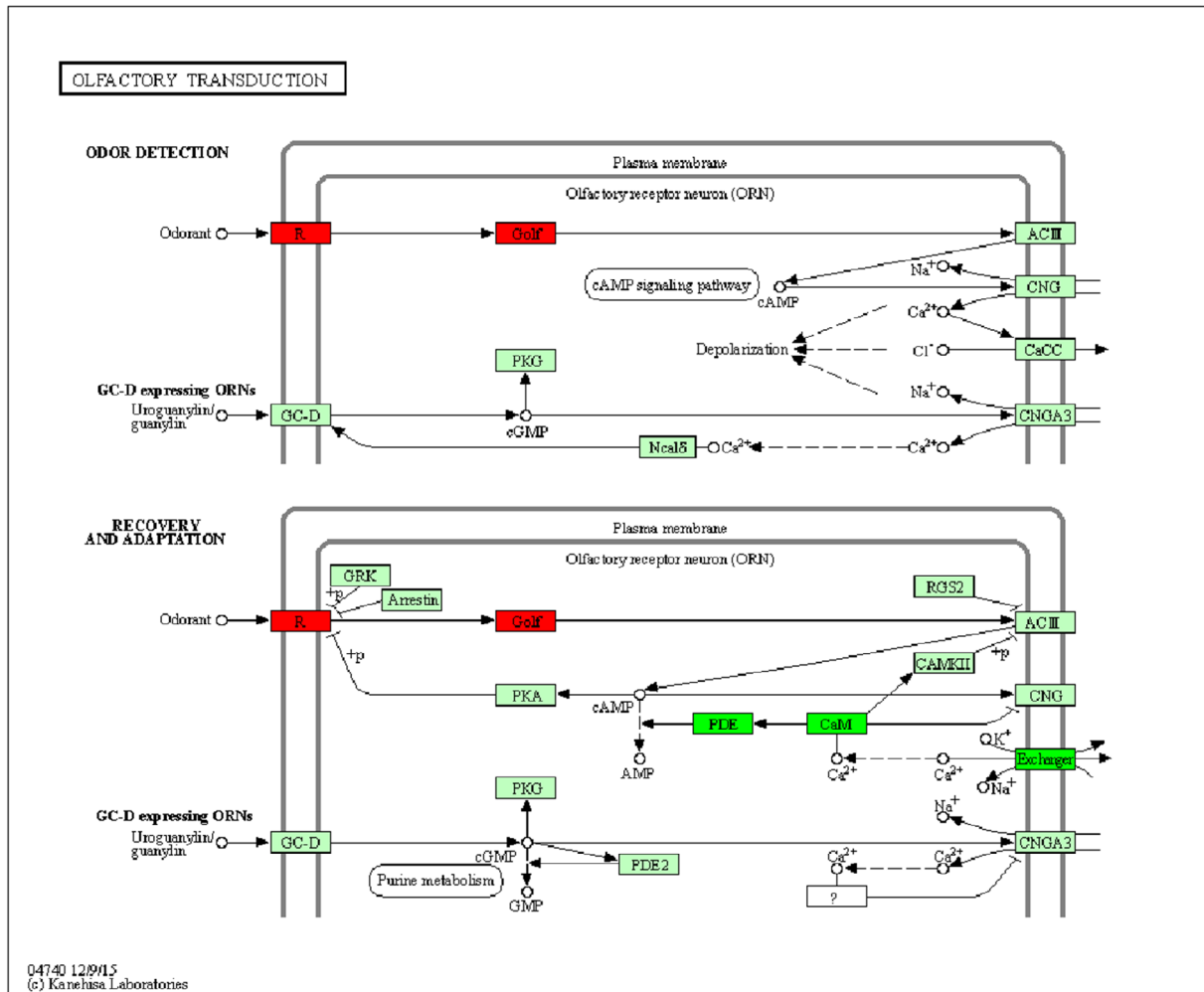

Figure 7. The KEGG pathway of DEGs associated with olfactory function.

norepinephrine to the olfactory bulb, play an essential role in impaired olfactory function in AD.³⁵

There were several strengths of our study. First, the study was general population based, reducing the potential selection bias. Second, the data in our study were obtained from face-to-face interviews, which are more reliable. Third, this study reported the differences of cognitive decline risk between the male group and female group, which provides more information on the predicted ability of olfactory function. Finally, prospective design allowed us to assess the association of olfactory dysfunction with decline in cognitive function.

There were some potential limitations to our study. First, the study participants were from Liaoning province, China. Thus, the generalizability of the result is limited. Furthermore, the average of participants is 60 years old and it is unclear whether our results are also applicable to the younger population. Second, olfactory function is

assessed by self-reported rather than other more accurate detection methods such as UPSIT. Cognitive function can be divided into various aspects such as discrimination, identification, recognition memory and naming, which are not considered comprehensively in this study. Third, medical history including hypertension, diabetes etc was abstracted by self-report rather than from medical records, which was less reliable and valid. Finally, the influence of several potential confounding factors can not be excluded.

Conclusion

Our findings suggest that impaired olfactory function is associated with poor cognitive function and decline in calculation domains of cognitive performance during follow-up, which may be used as a biomarker of early detection and an important predictor of persons at high

cognitive impairment risk, including olfactory transduction, detection of chemical stimulus involved in sensory perception of smell, sensory perception of smell, olfactory receptor activity and odorant binding.

Acknowledgments

Not applicable.

Conflict of Interest

None declared.

Author's Contributions

LQZ, ZQS and YNM contributed to the conception and design of the study. WY, RXL, HG, HSG, CYG and WJF conducted the research. JYS performed the data analysis, interpreted the data and completed the manuscript. LQZ reviewed and revised the manuscript critically. HQG contributed to the revision and development of the manuscript, including re-checking the accuracy of analysis methods and data. All authors read and approved the final manuscript.

Data Availability Statement

The datasets used and/or analyzed during the current study are available from the corresponding author on reasonable request, which are available in the GEO database and are included within the article.

References

- Murphy C, Schubert CR, Cruickshanks KJ, et al. Prevalence of olfactory impairment in older adults. *JAMA*. 2002;288(18):2307-2312.
- Cha H, Kim S, Son Y. Associations between cognitive function, depression, and olfactory function in elderly people with dementia in Korea. *Front Aging Neurosci*. 2021;13:799897.
- Ekstrom IA, Rizzuto D, Grande G, et al. Environmental air pollution and olfactory decline in aging. *Environ Health Perspect*. 2022;130(2):27005.
- Wilson RS, Schneider JA, Arnold SE, et al. Olfactory identification and incidence of mild cognitive impairment in older age. *Arch Gen Psychiatry*. 2007;64(7):802-808.
- Park H, Kim H, Kim S, et al. The association between olfactory function and cognitive impairment in older persons with cognitive impairments: a cross-sectional study. *Healthcare (Basel)*. 2021;9(4):399.
- Yan Y, Aierken A, Wang C, et al. A potential biomarker of preclinical Alzheimer's disease: the olfactory dysfunction and its pathogenesis-based neural circuitry impairments. *Neurosci Biobehav Rev*. 2022;132:857-869.
- Roberts RO, Christianson TJ, Kremers WK, et al. Association between olfactory dysfunction and amnesic mild cognitive impairment and Alzheimer disease dementia. *JAMA Neurol*. 2016;73(1):93-101.
- Esposito F, Cirillo M, De Micco R, et al. Olfactory loss and brain connectivity after COVID-19. *Hum Brain Mapp*. 2022;43(5):1548-1560.
- Kaya E, Göker AE. Olfactory dysfunction: its association with subjective cognitive impairment in patients with major depression. *J Nerv Ment Dis*. 2022;210(3):172-178.
- Dong J, Zhan X, Sun H, Fang F, Wei Y. Olfactory dysfunction is associated with cognitive impairment in patients with obstructive sleep apnea: a cross-sectional study. *Eur Arch Otorhinolaryngol*. 2022;279(4):1979-1987.
- Attems J, Walker L, Jellinger KA. Olfactory bulb involvement in neurodegenerative diseases. *Acta Neuropathol*. 2014;127(4):459-475.
- Devanand DP, Lee S, Manly J, et al. Olfactory deficits predict cognitive decline and Alzheimer dementia in an urban community. *Neurology*. 2015;84(2):182-189.
- Liang X, Ding D, Zhao Q, et al. Association between olfactory identification and cognitive function in community-dwelling elderly: the Shanghai aging study. *BMC Neurol*. 2016;16(1):199.
- Huang Z, Huang S, Cong H, et al. Smell and taste dysfunction is associated with higher serum Total cholesterol concentrations in Chinese adults. *J Nutr*. 2017;147(8):1546-1551.
- Chen KL, Xu Y, Chu AQ, et al. Validation of the Chinese version of Montreal cognitive assessment basic for screening mild cognitive impairment. *J Am Geriatr Soc*. 2016;64(12):e285-e290.
- Chobanian AV, Bakris GL, Black HR, et al. The seventh report of the joint National Committee on prevention, detection, evaluation, and treatment of high blood pressure the JNC 7 report. *JAMA*. 2003;289(19):2560-2572.
- Wang L, Li X, Wang Z, et al. Trends in prevalence of diabetes and control of risk factors in diabetes among US adults, 1999-2018. *JAMA*. 2021;326(8):1-13.
- Herbert A, Heron J, Barnes M, et al. Exploring the causal role of intimate partner violence and abuse on depressive symptoms in young adults: a population-based cohort study. *BMC Med*. 2022;20(1):1.
- Suri RM, Vanoverschelde JL, Grigioni F, et al. Association between early surgical intervention vs watchful waiting and outcomes for mitral regurgitation due to flail mitral valve leaflets. *JAMA*. 2013;310(6):609-616.
- Makizako M, Makizako H, Doi T, et al. Olfactory identification and cognitive performance in community-dwelling older adults with mild cognitive impairment. *Chem Senses*. 2014;39(1):39-46.

21. Wang QS, Tian L, Huang YL, et al. Olfactory identification and apolipoprotein E epsilon 4 allele in mild cognitive impairment. *Brain Res.* 2002;951(1):77-81.
22. Graves AB, Bowen JD, Rajaram L, et al. Impaired olfaction as a marker for cognitive decline: interaction with apolipoprotein E epsilon4 status. *Neurology.* 1999;53(7):1480-1487.
23. Swan GE, Carmelli D. Impaired olfaction predicts cognitive decline in nondemented older adults. *Neuroepidemiology.* 2002;21(2):58-67.
24. Djordjevic J, Jones-Gotman M, De Sousa K, et al. Olfaction in patients with mild cognitive impairment and Alzheimer's disease. *Neurobiol Aging.* 2008;29(5):693-706.
25. Umeda-Kameyama Y, Ishii S, Kameyama M, et al. Heterogeneity of odorant identification impairment in patients with Alzheimer's disease. *Sci Rep.* 2017;7(1):4798.
26. Kouzuki M, Suzuki T, Nagano M, et al. Comparison of olfactory and gustatory disorders in Alzheimer's disease. *Neurol Sci.* 2018;39(2):321-328.
27. Ervin KS, Lymer JM, Matta R, Clipperton-Allen AE, Kavaliers M, Choleris E. Estrogen involvement in social behavior in rodents: rapid and long-term actions. *Horm Behav.* 2015;74:53-76.
28. Hara Y, Waters EM, McEwen BS, Morrison JH. Estrogen effects on cognitive and synaptic health over the Lifecourse. *Physiol Rev.* 2015;95(3):785-807.
29. Sundermann EE, Fields A, Saloner R, et al. The utility of olfactory function in distinguishing early-stage Alzheimer's disease from HIV-associated neurocognitive disorders. *Aids.* 2021;35(3):429-437.
30. Olofsson JK, Larsson M, Roa C, Wilson DA, Jonsson Laukka E. Interaction between odor identification deficit and APOE4 predicts 6-year cognitive decline in elderly individuals. *Behav Genet.* 2020;50(1):3-13.
31. Moon J, Lee ST, Kong IG, et al. Early diagnosis of Alzheimer's disease from elevated olfactory mucosal miR-206 level. *Sci Rep.* 2016;4(6):20364.
32. Albers MW, Gilmore GC, Kaye J, et al. At the interface of sensory and motor dysfunctions and Alzheimer's disease. *Alzheimers Dement.* 2015;11(1):70-98.
33. Kovács T, Cairns NJ, Lantos PL. Olfactory centres in Alzheimer's disease olfactory bulb is involved in early Braak's stages. *Neuroreport.* 2001;12(2):285-288.
34. Lin FR, Metter EJ, O'Brien RJ, Resnick SM, Zonderman AB, Ferrucci L. Hearing loss and incident dementia. *Arch Neurol.* 2011;68(2):214-220.
35. Meshulam RI, Moberg PJ, Mahr RN, Mahr RN. Olfaction in neurodegenerative disease a meta-analysis of olfactory functioning in Alzheimer's and Parkinson's diseases. *Arch Neurol.* 1998;55(1):84-90.

Supporting Information

Additional supporting information may be found online in the Supporting Information section at the end of the article.

Table S1 Genes associated with olfactory function searching from GeneCards.

Table S2. The significant differentially expressed genes associated with olfactory function in the RRA analyses.

Figure S1. Heatmap of all differentially expressed genes associated with olfactory function in RRA analyses.

Figure S2. Gene Ontology (GO) analyses of all differentially expressed genes associated with olfactory function. (A) bar plot of GO analysis. (B) dot plot of GO analysis.

Figure S3. Gene Ontology (GO) analyses of all up-regulated genes in RRA analyses. (A) bar plot of GO analysis (B) dot plot of GO analysis.