



## Information-to-free-energy conversion: Utilizing thermal fluctuations

Shoichi Toyabe<sup>1</sup> and Eiro Muneyuki<sup>2</sup>

<sup>1</sup>*Systems Biophysics, Faculty of Physics, Ludwig-Maximilians-University Munich, Munich 80799, Germany*

<sup>2</sup>*Department of Physics, Faculty of Science and Engineering, Chuo University, Kasuga, Tokyo 112-8551, Japan*

Received April 11, 2013; accepted June 26, 2013

**Maxwell's demon is a hypothetical creature that can convert information to free energy. A debate that has lasted for more than 100 years has revealed that the demon's operation does not contradict the laws of thermodynamics; hence, the demon can be realized physically. We briefly review the first experimental demonstration of Maxwell's demon of Szilard's engine type that converts information to free energy. We pump heat from an isothermal environment by using the information about the thermal fluctuations of a Brownian particle and increase the particle's free energy.**

**Key words:** Maxwell's demon, nonequilibrium physics, Brownian motion, Jarzynski equality

### 1. Maxwell's demon

A glass of water contains about  $10^{24}$  water molecules. A water molecule moves at several hundred meters per second and collides with other molecules approximately  $10^{12}$  times per second. Thus, on a microscopic scale, a glass of water is a stormy chaotic world. We might then conclude that we can drive a car by using this large amount of energy contained in a glass of water. We can obtain a virtually infinite amount of water from the sea and use it to solve energy issues. However, this is in principle impossible. We cannot fully utilize the energy that is contained in the water, but we can use

only a fraction of it, which is the free energy. This is one of the several equivalent expressions of the second law of thermodynamics. This arises because water molecules move randomly. In order to fully utilize the energy, we would need to have the complete information about the movement of molecules. However, only limited statistical information such as the temperature and the pressure is available to us. The lack of information about the system corresponds to the entropy. In other words, if we could somehow observe the movement of some molecules and in this way obtain more information about the system, we could use this information to increase the energetic yield. A hypothetical creature that achieves this operation is known as Maxwell's demon, which was first proposed by James Clerk Maxwell more than 150 years ago<sup>1</sup>.

### 2. Szilard engine

Let us start by introducing the gedankenexperiment that was first proposed by Leo Szilard<sup>2</sup>. His "Szilard engine" retains the essence of Maxwell's demon, but is simpler than Maxwell's original version. Szilard engine clarifies the quantitative relation between some thermodynamic quantities and "information."

The Szilard engine operates as follows (Fig. 1). A molecule is moving inside a box made of a diathermal wall. We slowly insert a thin wall at the center. Then, the position of the molecule is measured. The molecule can be found either in the left or in the right chamber of the box, with equal probability. If the molecule is found in the left chamber, a weight is attached to the left-hand side of the wall. However, if the molecule is found in the right chamber, a weight is attached to the right-hand side of the wall. The weight can

Corresponding author: Eiro Muneyuki, Department of Physics, Faculty of Science and Engineering, Chuo University, Kasuga 1-13-27, Tokyo 112-8551, Japan.  
e-mail: emuneyuk@phys.chuo-u.ac.jp

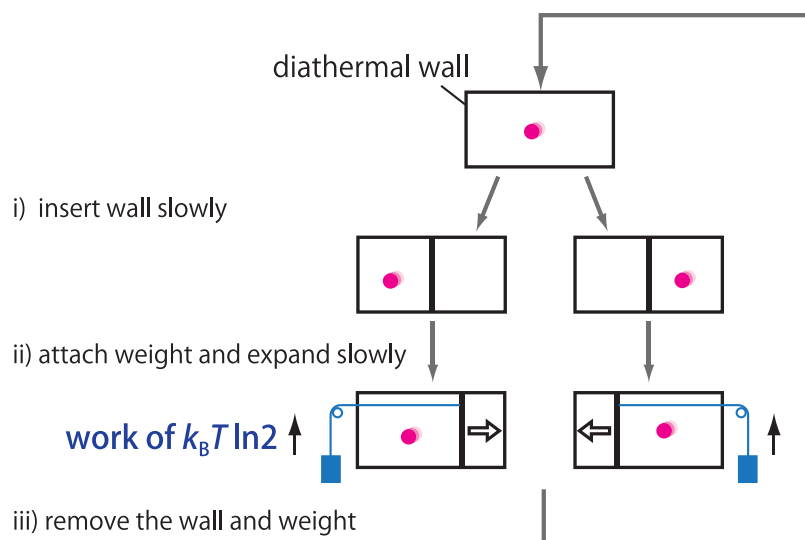

**Figure 1** Szilard engine is an essential model of Maxwell's demon that allows us to treat the quantitative relation between the information and operation. In each cycle, the engine performs a work of  $k_B T \ln 2$ .

be lifted by moving the wall and expanding the chamber. Because the volume of the chamber becomes doubled following this operation, we obtain a work of  $k_B T \ln 2$  if we move the wall sufficiently slowly in a quasistatic process. By removing the wall and the weight, the system is reset to the initial state.

Note that, in theory, no work needs to be done to insert the wall and to attach/detach the weight to/from the wall. Nevertheless, an amount of work given by  $k_B T \ln 2$  is obtained during each cycle. This would simply be a perpetual motion machine of the second type, and thus would contradict the second law of thermodynamics. However, we empirically believe that the second law of thermodynamics is never violated. How, then, can this model be reconciled with the second law of thermodynamics? This problem is known as the Maxwell's demon paradox<sup>1,3</sup>, and it was solved more than one hundred years after the introduction of Maxwell's demon.

The clue to the solution was a novel concept introduced in physics, namely, "information." The engine's operator, or the demon, determines the position of a molecule to obtain information about the chamber in which the particle resides. The demon records this information in its memory and operates the engine on the basis of this information. In order to repeat the cycle, the demon needs to delete the information in the memory at the end of a cycle. Otherwise, the system, including the engine and the demon, would not reset to its initial state at the end of a cycle. Interestingly, it was theoretically revealed that the information processing performed by the demon requires the consumption of free energy.

### 3. Information and physics

How can we treat "information" in physics? The term "information" sounds intangible. However, when we observe our surroundings, we recognize that information never exists by itself but is always encoded in physical entities such as an electric voltage, bumps on a compact disc surface, and the direction of a magnet. Therefore, procedures that relate to information processing such as the acquisition of information, erasure, communication, and copying are always associated with physical processes and are thus governed by the laws of physics.

Let us think of events that occur stochastically, such as whether it rains or not. Shannon defined the information content that is obtained by observing an event that occurs with the probability  $p$  as  $-\log p$ . This definition satisfies the properties that information content should have<sup>4</sup>. Information content quantifies to what extent the event is surprising; it takes on a large value when a rare event is observed. The average information content that is obtained by the measurement is

$$H = -p \log p - (1-p) \log(1-p)$$

in the case wherein two possible events occur with probabilities  $p$  and  $1-p$ , respectively. The Shannon information content  $H$  quantifies the amount of uncertainty that is reduced by the measurement.  $H=0$  when  $p=1$  or  $0$ ; no information is obtained when the result is completely predictable.  $H$  attains its maximum value  $\log 2$  when  $p=1/2$ ; maximum information is obtained when the chances of different outcomes are equal and the result cannot be predicted. The measurement is not always perfect and thus often suffers from errors. The information content that includes the measurement error is quantified with the mutual information content  $I$ . The

mutual information content is the Shannon information content that is shared by the observer and the system<sup>5</sup>. For error-free measurement, one obtains  $I=H$ .

#### 4. Cost of information processing

Let us again consider the Maxwell's demon paradox. The information processing tasks performed by the demon are acquiring information by measurement and erasing information. Brillouin discussed the thermodynamic cost of the measurement<sup>1</sup>. He thought that at least one photon is necessary to measure the position of a molecule. However, a photon that has the energy of  $k_B T$  exists in the proximity of the molecule because of black-body radiation. In order to measure the molecule's position in such a background, a photon with energy much higher than  $k_B T$  is necessary. Brillouin noticed that, if the energy cost for the measurement is accounted for, the demon cannot extract net positive work from Szilard engine, which does not contradict the second law. However, later, Charles Bennett proposed a mechanical measurement method that does not utilize photons. He showed that the state of a system can be measured without performing work.

However, Landauer and Bennett showed that some work needs to be performed to delete information<sup>6-8</sup>. They modeled the demon's memory as a particle in a box (Fig. 2a) and showed that an amount of work of at least  $k_B T \ln 2$  is necessary to delete 1 bit of information (Landauer's principle). When this work is included in the calculation, the demon does not violate the second law of thermodynamics. It may be not easy to understand why work needs to be performed

to delete information. Subsequent to the measurement, the state of the memory becomes either L or R. The important point to realize is that the entropy of the memory increases after the measurement, because the memory's state is not known to the operator who deletes the memory information. Therefore, in order to reset the memory's state, some work needs to be performed to reduce the entropy.

Landauer and Bennett used a symmetric memory model to discuss the energy cost associated with erasing information. Sagawa and Ueda found that the amount of work required to delete information can be less than  $k_B T \ln 2$  when the memory is asymmetric<sup>9</sup> (Fig. 2b). When the asymmetry was tuned, the work  $W_{\text{delete}}$  that was required to delete the information became zero. However, in this case, the work  $W_{\text{measure}}$  had to be performed to measure the system and write the memory. They showed that the sum of  $W_{\text{measure}}$  and  $W_{\text{delete}}$  of the mutual information content  $I$  is always greater than  $k_B T I$ . In this sense, the original Landauer's principle is limited to a special case in which the memory is symmetric, whereas there is a tradeoff between the work that needs to be performed for the measurement and the work that is needed for the information erasure. Further, Sagawa and Ueda showed that the maximum work that can be extracted by using  $I$  is  $k_B T I$ <sup>10</sup>:

$$W_{\text{measure}} + W_{\text{delete}} \geq k_B T I \geq W_{\text{output}} \quad (1)$$

This is the contemporary expression that captures the consistency of Maxwell's demon with the second law of thermodynamics. Note that Szilard engine achieves the equality of the right-hand side in (1).

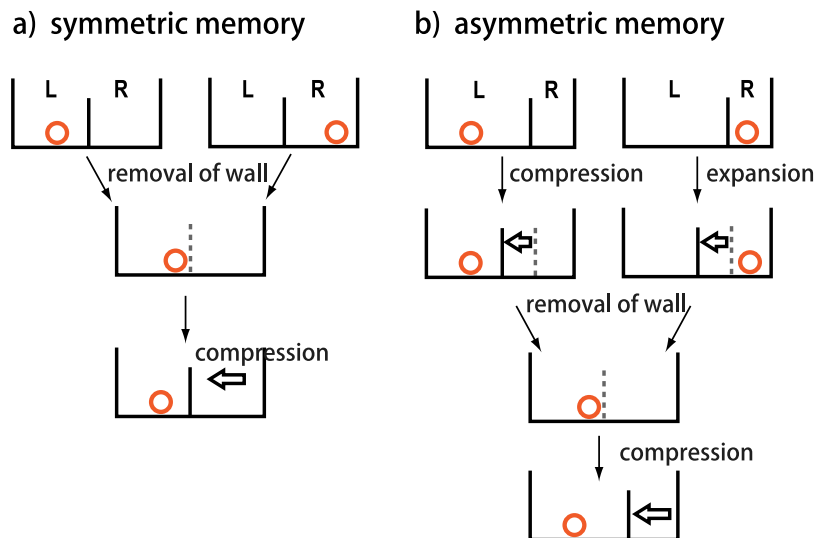

**Figure 2** Erasure of information in memory. a, A symmetric memory model that was proposed by Landauer and Bennett. Information in the memory is deleted without knowing the memory's state. The initial state is L. A measurement corresponds to placing the particle in either L or R. Information is deleted by removing the wall and by compressing, to move the particle to the initial state L. This uncorrelates the memory's state with the measurement result. b, Asymmetric memory model by Sagawa and Ueda.

## 5. Experimental demonstration of information to free energy conversion

We learn two things from the long-standing debate regarding Maxwell's demon. First, as noted, information is always encoded in physical properties. Information processing is always a physical process that is governed by the laws of physics. Second, we can obtain free energy from an isothermal environment by acquiring information about the microscopic degrees of freedom. However, despite its importance in both science and technology, such information-to-free-energy conversion has not been achieved. We demonstrated information-to-free-energy conversion for the first time by performing a high-speed feedback control of a Brownian particle<sup>11</sup>.

A dimeric plastic particle was pinned at a glass surface with a protein elastic linker in a chamber filled with water (Fig. 3a). The particle could rotate freely around the fixed

point and showed rotational Brownian movement. Quadrant electrodes were patterned on the lower glass surface. An 1-MHz high frequency voltage was applied to the electrodes<sup>12–15</sup>. By shifting the phases of the voltages, an elliptically rotating electric field (EREF) could be generated at the center of the electrodes. Under the EREF, the particle experiences a periodic potential with a gradient. The potential is found comparable to the thermal energy  $k_B T$ ; peak-to-peak height is found to be approximately  $3k_B T$ . The slope was approximately  $k_B T$  per rotation. Because we used electric field, the axial direction of the EREF could be instantaneously switched. The potential's phase was inverted when the EREF direction was rotated by  $90^\circ$ .

A feedback control was performed as follows (Fig. 3b). The particle's angular position was measured first. This was achieved by a real-time analysis of the particle image recorded by a high-speed camera. In most cases, the particle was found near the potential minima. However, excited by

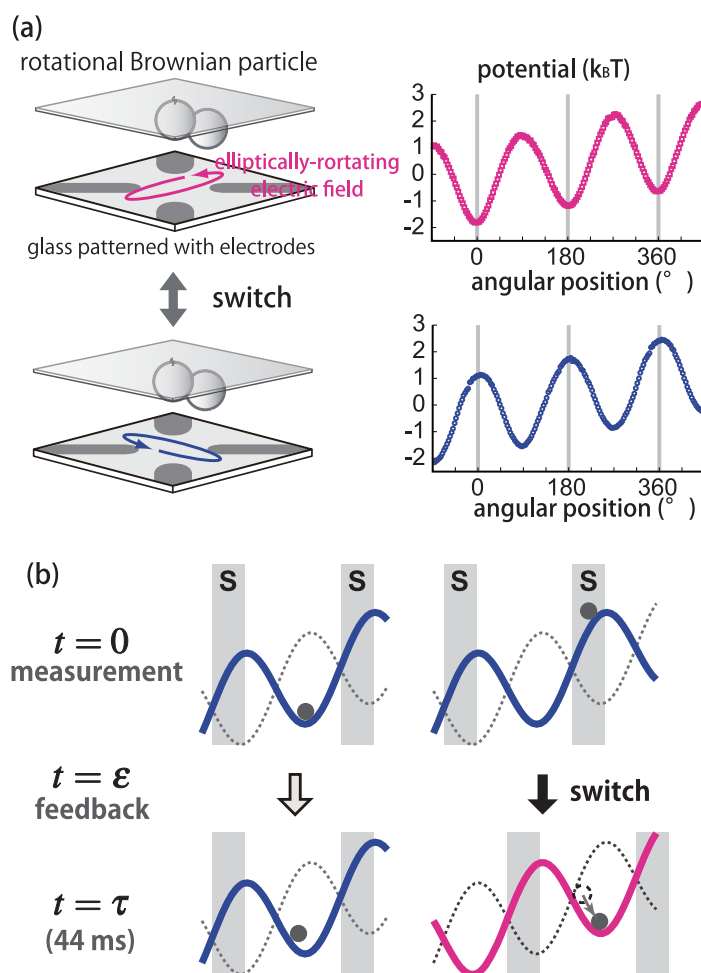

**Figure 3** The experiment. a, A dimeric particle was attached to the upper glass surface. Because the particle is pinned at a single point, it can freely rotate. An elliptically-rotating electric field is generated at the center of the quadrant electrodes patterned on the bottom glass surface. This imposes on the particle a periodic potential with a gradient. By switching the direction of the electric field, we can shift the phase of the potential. b, Feedback control. When the particle is observed in the region S, the potential is switched after a time delay  $\epsilon$ . One cycle is 44 ms.

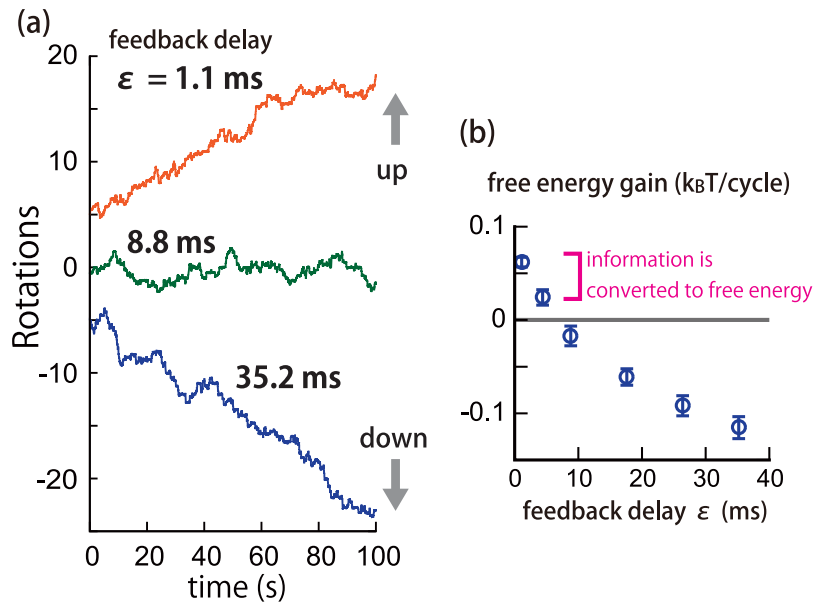

**Figure 4** Results. a, Rotational trajectories under feedback control with different feedback delay times. Particle climbs up the gradient because of feedback control on the basis of the particle's position. b, The free energy gained by the particle. For a short feedback delay, the particle obtains free-energy gain that exceeds the conventional limit imposed by the second law of thermodynamics.

thermal fluctuations, the particle was sometimes found in the region “S” that was higher than the minima. When the particle was observed in S, the potential was switched after a time delay  $\varepsilon$ , to prevent the particle from going back to the original position. Otherwise, when the particle was not observed to be in S, no action was taken. When the potential was switched, the particle climbed up a step with a high probability. Hence, we expected the particle to climb up the gradient upon the repetition of the feedback control. This experiment essentially mimics the Szilard engine (Fig. 1). The weight in Szilard engine is now the electric potential that is imposed on the particle. The demon is a computer program running on a PC and the camera. The insertion of a wall corresponds to the potential switch. The difference between this experiment and Szilard engine is in the order of the measurement and wall's insertion. In Szilard engine, the wall was inserted before the measurement, whereas in our experiment the potential was switched after the measurement.

In Figure 4a, we showed that, on average, the particle climbs up the gradient when the feedback delay  $\varepsilon$  is short. When  $\varepsilon$  is large, the particle returns to the potential minima before the switching of the potential even if the particle is found in S. In contrast to Szilard engine, the switching of the potential in our experiment is accompanied by work. The case in which the particle climbs up the gradient simply because it is pushed up by some external work would be trivial. In order to reveal the thermodynamic relations, we measured the work associated with switching the potential and the free energy increase per cycle (Fig. 4b). We found that, for a short  $\varepsilon$ , the particle obtained a free-energy gain that was larger than the work that was performed on the

particle by switching the potential. In this case, the second law of thermodynamics is apparently violated. This was possible in our experiment, because we controlled the particle with a feedback control on the basis of the information about the microscopic movement of the particle. When the particle was excited thermally and climbed up to the region S, the energy absorbed from the thermal fluctuation was not returned to the environment but was gained by the switching of the potential.

We can evaluate the information content that is obtained by the measurement. Our measurement amounted to observing whether the particle is in the region S. Let  $p$  be the probability that the particle is found in S, which is equal to the fraction of the cycles in which the potential is switched. The Shannon information content that is obtained by the measurement is  $H = -p \log p - (1-p) \log(1-p)$ . Because the measurement error is negligible in this experiment, the mutual information content  $I$  is equal to  $H$ . We can define the information-to-free-energy conversion efficiency as the net free energy gain divided by  $k_B T I$ . The efficiency was about 30% at the maximum.

In the microscopic system, the work and the free energy are fluctuating variables<sup>16</sup>. The second law of thermodynamics is an inequality that involves the averaged values of these quantities. On the other hand, Jarzynski's equality is an equality that includes the fluctuations of these quantities, and it generalizes the second law of thermodynamics<sup>17</sup>. This equality is not applicable to the present system with a feedback control because a fixed control is assumed in the equality. Recently, Sagawa and Ueda derived a generalized Jarzynski's equality that is applicable to the system with

feedback controls<sup>18</sup>. We verified the validity of this equality to a high accuracy<sup>11</sup>.

## 6. Summary

We demonstrated the conversion from information to free energy. Using a feedback control based on the information about the thermal motion of a Brownian particle, we obtained a free-energy gain that exceeded the conventional limit imposed by the second law of thermodynamics. The entropy around the PC (demon) increased much more than the free-energy gain in the microscopic system. Therefore, the second law holds when we consider the system as a whole including the demon and the system. However, when we focus on the microscopic system, it appears that the information is converted into free energy.

The efficiency of 30% is much lower than the 100% efficiency that is achieved by Szilard's engine. The main reason for such a low efficiency is that we utilized only a part of the obtained information. We only switched the potential when the particle was found in the region S. Otherwise, no action was taken, and the obtained information was wasted. In addition, a recent theoretical work suggests that, to obtain a high efficiency, there is a need to modulate not only the phase of the potential but also its height<sup>19</sup>. Experimental demonstration of 100% efficiency is another intriguing challenge.

In the present system, the particle and the demon were located far from each other. We can state that a free energy was transferred to the particle remotely, implying the future possibility of a novel controlling method for nano-sized machines. Instead of implementing the engine to the machine, we can drive it by modulating its environment according to the information about its thermal motions. It might be also intriguing to think that some molecular motors have already implemented such "demonic" machinery in order to achieve a high efficiency<sup>20</sup>.

This work was based on a collaboration with Takahiro Sagawa, Masahito Ueda, and Masaki Sano and was supported by the Japan Science and Technology Agency (JST) and Grant-in-Aid for Scientific Research (KAKENHI). S. T. was supported by the Alexander von Humboldt Foundation.

## References

1. Leff, H. S. & Rex, A. F. *Maxwell's Demon 2: Entropy, Classical and Quantum Information, Computing*. (Institute of Physics Publishing, Bristol, 2003).
2. Szilard, L. On the decrease of entropy in a thermodynamic system by the intervention of intelligent beings. *Z. Physik* **53**, 840–856 (1929).
3. Maruyama, K., Nori, F. & Vedral, V. Colloquium: The physics of Maxwell's demon and information. *Rev. Mod. Phys.* **81**, 1–23 (2009).
4. Shannon, C. E. A Mathematical theory of communication. *Bell Sys. Tech. J.* **27**, 379–423, 623–656 (1948).
5. Cover, T. M. & Thomas, J. A. *Elements of Information Theory*. (John Wiley and Sons, New York, 1991).
6. Landauer, R. Irreversibility and heat generation in the computing process. *IBM J. Res. Dev.* **5**, 183–191 (1961).
7. Bennet, C. H. The thermodynamics of computation—a review. *Int. J. Theor. Phys.* **21**, 905–940 (1982).
8. Bérut, A., Arakelyan, A., Petrosyan, A., Ciliberto, S., Dillenschneider, R. & Lutz, E. Experimental verification of Landauer's principle linking information and thermodynamics. *Nature* **483**, 187–189 (2012).
9. Sagawa, T. & Ueda, M. Minimal energy cost for thermodynamic information processing: Measurement and information erasure. *Phys. Rev. Lett.* **102**, 250602 (2009).
10. Sagawa, T. & Ueda, M. Second law of thermodynamics with discrete quantum feedback control. *Phys. Rev. Lett.* **100**, 080403 (2008).
11. Toyabe, S., Sagawa, T., Ueda, M., Muneyuki, E. & Sano, M. Experimental demonstration of information-to-energy conversion and validation of the generalized Jarzynski equality. *Nature Physics* **6**, 988–992 (2010).
12. Washizu, M., Kurahashi, Y., Iochi, H., Kurosawa, O., Aizawa, S., Kudo, S., Magariyama, Y. & Hotani, H. Dielectrophoretic measurement of bacterial motor characteristics. *IEEE Trans. Ind. Appl.* **29**, 286–294 (1993).
13. Watanabe-Nakayama, T., Toyabe, S., Kudo, S., Sugiyama, S., Yoshida, M. & Muneyuki, E. Effect of external torque on the ATP-driven rotation of F<sub>1</sub>-ATPase. *Biochem. Biophys. Res. Comm.* **366**, 951–957 (2008).
14. Toyabe, S., Okamoto, T., Watanabe-Nakayama, T., Taketani, H., Kudo, S. & Muneyuki, E. Nonequilibrium energetics of a single F<sub>1</sub>-ATPase molecule. *Phys. Rev. Lett.* **104**, 198103 (2010).
15. Toyabe, S., Watanabe-Nakayama, T., Okamoto, T., Kudo, S. & Muneyuki, E. Thermodynamic efficiency and mechanochemical coupling of F<sub>1</sub>-ATPase. *Proc. Nat. Acad. Sci. USA* **108**, 17951–17956 (2011).
16. Bustamante, C., Liphardt, J. & Ritort, F. The nonequilibrium thermodynamics of small systems. *Physics Today* **58**, 43–48 (2005).
17. Jarzynski, C. Nonequilibrium equality for free energy differences. *Phys. Rev. Lett.* **78**, 2690–2693 (1997).
18. Sagawa, T. & Ueda, M. Generalized Jarzynski Equality under Nonequilibrium Feedback Control. *Phys. Rev. Lett.* **104**, 090602 (2010).
19. Bauer, M., Abreu, D. & Seifert, U. Efficiency of a Brownian information machine. *J. Phys. A* **45**, 162001 (2012).
20. Toyabe, S., Ueno, H. & Muneyuki, E. Recovery of state-specific potential of molecular motor from single-molecule trajectory. *EPL* **97**, 40004 (2012).