



Overcoming supply disruptions during pandemics by utilizing found hardware for open source gentle ventilation



S. Oberloier^a, N. Gallup^{b,*}, J.M. Pearce^{c,1}

^a Department of Electrical & Computer Engineering, Michigan Technological University, Houghton, MI 49931, USA

^b Department of Biomedical Engineering and Mechanical Engineering, Michigan Technological University, Houghton, MI 49931, USA

^c Department of Electrical & Computer Engineering, Western University, London, ON N6A 3K7, Canada

ARTICLE INFO

Article history:

Received 11 August 2021

Received in revised form 9 December 2021

Accepted 18 December 2021

Keywords:

Appropriate technology

COVID-19

Improvisation

Medical equipment

Open hardware

Repurposed hardware

Ventilation

Open source

ABSTRACT

This article details the design of an open source emergency gentle ventilator (gentle-vent) framework that can be used in periods of scarcity. Although it is not a medical device, the system utilizes a wide range of commonly-available components that are combined using basic electronics skills to achieve the desired performance. The main function of the gentle-vent is to generate a calibrated pressure wave at the pump to provide support to the patient's breathing. Each gentle-vent permutation was tested using a DIY manometer as it would be utilized in the field in low-resource settings and validated with an open source VentMon. The most rudimentary implementation costs less than \$40.

© 2021 Published by Elsevier Ltd. This is an open access article under the CC BY-NC-ND license (<http://creativecommons.org/licenses/by-nc-nd/4.0/>).

Specifications table

Hardware name	<i>Open Source Gentle Ventilator</i>
Subject area	<ul style="list-style-type: none"> • Engineering and materials science • Medical • Other – Medical Device
Hardware type	No Commercial Analog Available
Closest commercial analog	GNU General Public License (GPL) 3.0
Open source license	\$37.80
Cost of hardware	https://osf.io/ug4z2/ and registration: https://doi.org/10.17605/OSF.IO/UV9MZ
Source file repository	

* Corresponding author.

E-mail address: ngallup@mtu.edu (N. Gallup).

¹ Given his role as Co-Editor in Chief, Joshua Pearce had no involvement in the peer-review of this article and has no access to information regarding its peer-review. Full responsibility for the editorial process for this article was delegated to Prof. Todd Duncombe.

<https://doi.org/10.1016/j.ohx.2021.e00255>

2468-0672/© 2021 Published by Elsevier Ltd.

This is an open access article under the CC BY-NC-ND license (<http://creativecommons.org/licenses/by-nc-nd/4.0/>).

Hardware in context

The COVID-19 pandemic [1] created temporary shortages of medical equipment like ventilators in the U.S. [2] and in Europe [3] as well as personal protective equipment (PPE) locally [4-6]. With the recent maturation of distributed manufacturing [7] in the context of small businesses [8], fab labs and makerspaces [9,10], and even in the home [11-14] there appears to be an opportunity for distributed manufacturing of medical hardware during pandemics [15] and can outlive for future use, especially when needed for short term management [16]. Thus, not only was there a global interest in ventilator production using conventional methods [17-19], but also for distributed open source ventilators with various degrees of success [20-27]. World economies, however, were being shocked by supply line shortages [28], which leave both commercial and open designs more difficult to reproduce [29,30]. Even if the open designs of conventional ventilators were easily reproducible there is evidence to suggest that ventilators are not necessarily the correct response to COVID-19 symptoms, and instead a gentle ventilation is required [31-33]. The main function of the gentle-ventilator approach is to generate a calibrated pressure wave to provide support to the patient's breathing. It is non-invasive and needs to be calibrated to ensure the maximum pressure is below the threshold to damage the user. The problem is a low-cost open source gentle ventilation easily adaptable design is needed for emergency situations where full medical equipment is unavailable.

This objective of this article is to provide a flexible design family of gentle ventilators (gentle-vents), which utilizes commonly available components. It is hypothesized that by using repurposed hardware, the design can be replicated at little to no cost with common household items in most of the world. Although there are other specific gentle ventilator designs available this approach is novel, because it provides a method to fabricate a functional gentle vent even when specific components are unavailable (e.g. during supply chain disruptions, emergencies, or in isolated communities). The design outlined in this article is also original because it is specified such that a wide range of parts can be combined to achieve the desired end product. It is thus more than a single design, but a library or family of designs that can be understood following the process in this article. It should be stressed, however, that it is not a medical device.

The gentle-vent can be replicated using very basic electronics skills and (depending on your hardware availability) can be constructed on a breadboard. The firmware is programmed in the Arduino Integrated Development Environment (IDE) [34], using the prolific low-cost Arduino Nano. The firmware's main function is to generate a calibrated pressure wave at the pump to provide support to the patient's breathing.

COVID-19 poses a great risk to citizens of nations that do not have enough medical equipment to support all of the potential patients generated from the pandemic [35]. The gentle-vent can help provide support for impoverished citizens with sick loved ones who have been turned away by their medical providers. Those who have underlying respiratory conditions, those with acute respiratory syndrome, or atelectasis are subject to a more severe case of COVID-19 and similar diseases. Thus, a gentle-vent is geared towards them. A mechanical ventilator, or breathing machine, can be too much for someone with these circumstances due to the forceful distribution of air in their lungs. A standard ventilator pushes air at a rhythmic pace. If the patient does not breath at the same rhythm as the ventilator, the lungs receive unwanted pressure from excessive oxygen, thus damaging tissue within and around the lungs [36]. Mechanical ventilators are also meant for someone who needs assistance in the long-term, thus raise speculation and concern for more health issues problems to occur, such as pneumonia or vocal cord damage.

Hardware description

The gentle-vent design follows open hardware design protocols [37,38], which consists of a flexible hardware configuration inspired by an existing open source design by Lee [39] and firmware, which can be suited to many hardware configurations.

Hardware

The mechanical system consists of a direct connection of a mouthpiece to an air pump via a short length of tube, which can be seen in Fig. 1.

In order to demonstrate the flexibility of this design, three different air pumps are tested in conjunction with differing electronic control setups.

Like similar projects, 3-D printing is useful for specialty components during a pandemic [39]. The mouthpiece [40] is printed from polylactic acid (PLA) using an open source Ender 3 3-D printer [41]. The part is sliced using open source Cura [42] with a layer height of 0.2 mm and a completely solid infill. The part has a mass of 23 g and costs about US\$ 0.21 to print from commercial filament.

Parametric adaptors, which can also be 3-D printed [43], can be used to connect varying sizes of hose to output ports on pumps. The adaptor can be printed using the same settings as were used for the mouthpiece. It has a mass of 12 g and costs US\$0.14 to print.

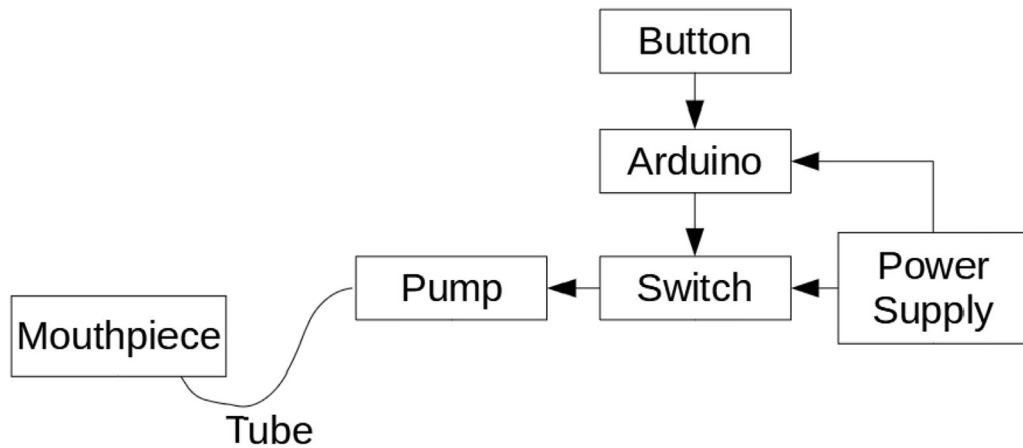

Fig. 1. System overview of the open source gentle-vent library. Each component can be replaced by several options depending upon circumstance and availability.



Fig. 2. a) Rendering of the mouthpiece, b) 3-D printed mouthpiece.

Electronics

In this implementation an Arduino Nano is used for pump control, as it is the least expensive option and easiest to integrate [34]. Any other devices in the Arduino family (other common and compatible options are listed in Table 2) could be used as a controller, as long as a single pulse width modulation (PWM) output pin is available.

Any NPN or N-Type transistor (Table 3) will work as a switching device, and in this implementation a TIP 120 Darlington pair transistor is used. Additionally, switching devices such as solid-state relays (SSR) will also function effectively. Mechanical relays, however, are not capable of PWM control and cannot be used for this application.

A single momentary switch can be used to signal to the Arduino to switch pressure-states. A resistor divider connected to a digital input can be used to monitor the PWM signal on the output end of the switching device. A complete schematic of the device is shown in Fig. 4.

Table 1

Key characteristics of the tested pumps.

Name	Voltage (VDC)	Max Pressure (in H ₂ O)	Cost (USD)	URL
Pump 1	12	6.5	\$11.99	https://www.amazon.com/dp/B07F3QF4B4
Pump 2		6.25	\$19.59	https://www.amazon.com/dp/B074NZY3SQ
Pump 3		22.25	\$62.99	https://www.amazon.com/dp/B000OF92KA

Table 2

Examples of compatible controllers.

Name	Type	Cost (USD)	URL
Controller 1	Arduino Nano	\$3.60	https://www.amazon.com/dp/B07RQ8S1LG
Controller 2	Arduino Uno	\$23.00	https://www.amazon.com/dp/B008GRTSV6
Controller 3	Arduino Mega	\$19.99	https://www.amazon.com/dp/B01H4ZLZLQ

The device can be prototyped on a breadboard, but the connections can be easily broken and in many cases the traces are not rated for the max current of the pump [44]. Though in extreme cases of scarcity, a breadboard can be implemented for long-term use if the cables for the power supply and pump are well secured. An image of the controller implemented on a breadboard can be seen in Fig. 5. The bill of materials (BOM) can be seen in Table 4 (total cost US\$5.93).

Table 3
Switching devices utilized in this experiment.

Name	Type	Cost (USD)	URL
Switch 1	TIP 120 Transistor	\$0.44	https://www.amazon.com/dp/B07LG2C3MY
Switch 2	40A DC SSR	\$12.99	https://www.amazon.com/dp/B079BGGVYX



Fig. 3. a) Rendering of the hose adaptor, b) 3-D printed hose adaptor.

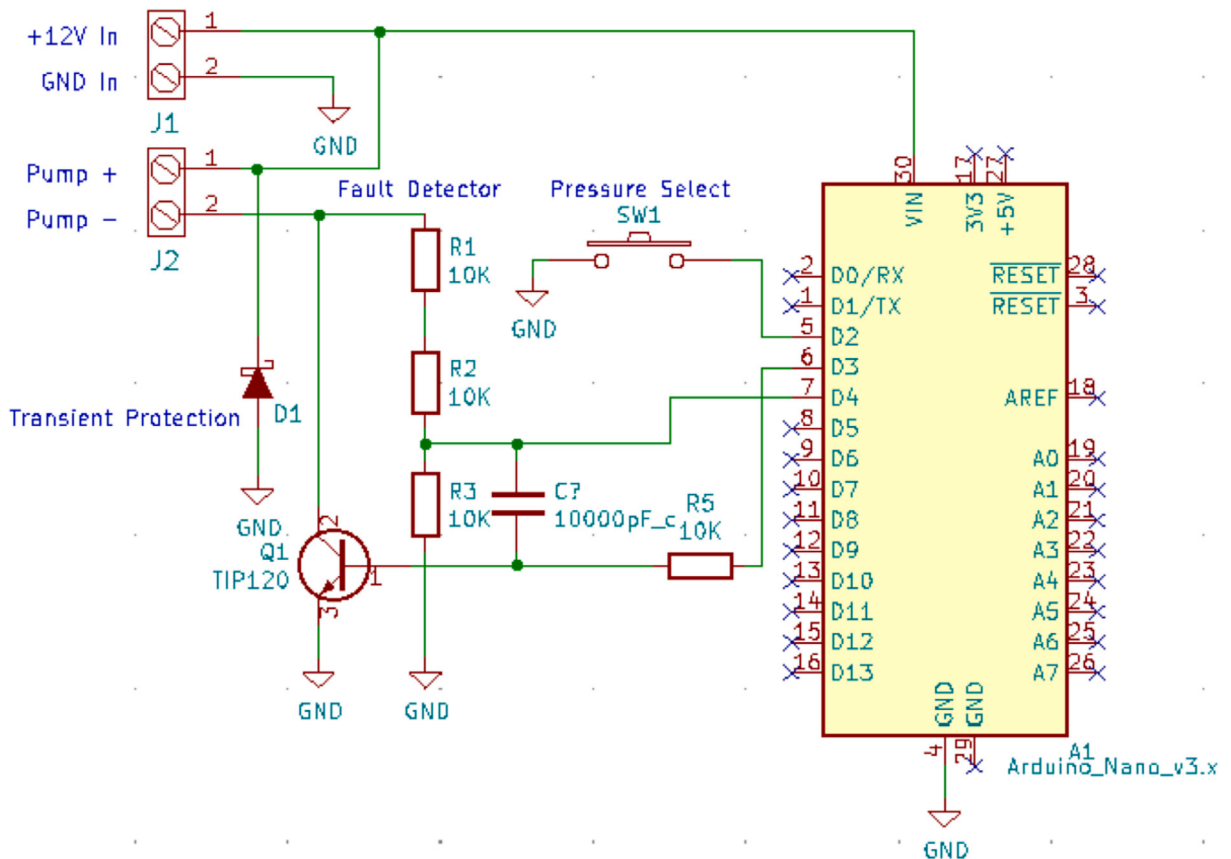

Fig. 4. Schematic for a TIP120-based pump controller.

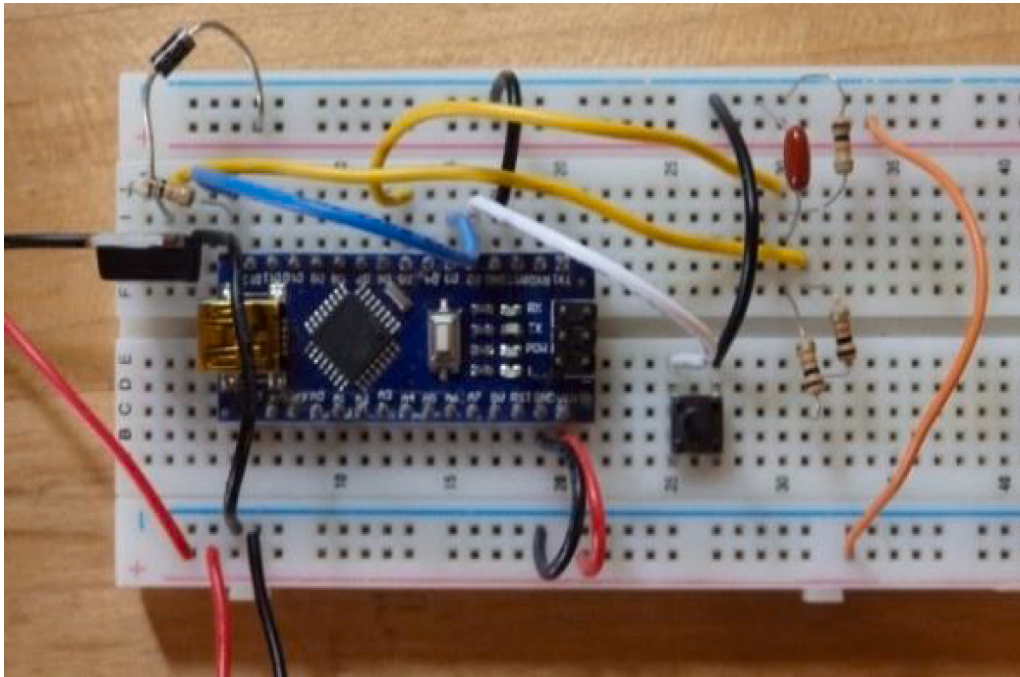

Fig. 5. Transistor-based controller implemented on breadboard.

Table 4

BOM for transistor-based implementation on breadboard.

Qty	Description	Cost (USD)	URL
1	Breadboard	\$1.50	https://www.amazon.com/dp/B07PCJP9DY
2 ft	Wires	\$0.16	https://www.amazon.com/dp/B07TX6BX47
1	Button	\$0.07	https://www.amazon.com/dp/B01N6GU7TA
4	10 k Resistors	\$0.30	https://www.amazon.com/dp/B0185FIOTA
1	10nF Capacitor	\$0.05	https://www.amazon.com/dp/B07KG3F6M3/
1	1 N4007 Diode	\$0.25	https://www.amazon.com/dp/B00W17LOBO/
1	Arduino Nano	\$3.60	https://www.amazon.com/dp/B07RQ8S1LG

An improved and more robust, yet still easily improvised implementation can be done on a perf-board, which will require basic soldering as shown in Fig. 6. The bill of materials (BOM) can be seen in Table 5 (total cost US\$4.89).

If a circuit milling machine [45] is available, a single-layered board can be milled using the design files available on [43]. Additionally, this design could be mass-produced via third-party board manufacturing services. The implementation

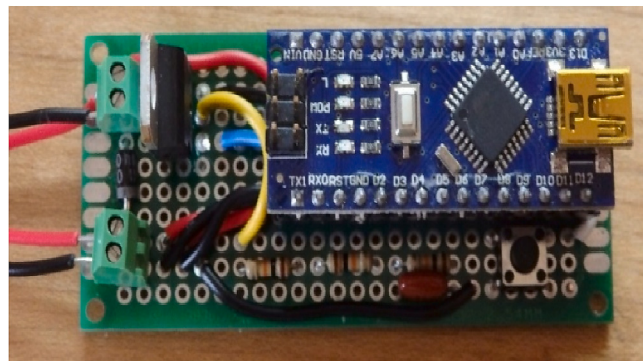

Fig. 6. An image of the transistor-based controller implemented on a perf-board. Note that terminal blocks are not required – the leads of the pump can be cut and soldered directly as a cost saving / availability measure.

Table 5
BOM for transistor-based implementation on perf-board.

Qty	Description	Cost (USD)	URL
1	Perf-board	\$0.29	https://www.amazon.com/dp/B07FFDFLZ3
2 g	Solder	\$0.17	https://www.amazon.com/dp/B075WB98FJ/
2 ft	Wires	\$0.16	https://www.amazon.com/dp/B07TX6BX47
1	Button	\$0.07	https://www.amazon.com/dp/B01N6GU7TA
4	10 k Resistors	\$0.30	https://www.amazon.com/dp/B0185FIOTA
1	10nF Capacitor	\$0.05	https://www.amazon.com/dp/B07KG3F6M3/
1	1 N4007 Diode	\$0.25	https://www.amazon.com/dp/B00W17LOBO/
1	Arduino Nano	\$3.60	https://www.amazon.com/dp/B07RQ8S1LG

requires basic soldering. A rendering of the controller implemented on a printed circuit board (PCB) can be referenced below in Fig. 7. The BOM can be seen in Table 6 (with a total cost of US\$5.61).

Regardless of the implementation, any 12 V DC supply can be used (given it has sufficient current to run the selected motor). Four different supplies are tested (Table 7).

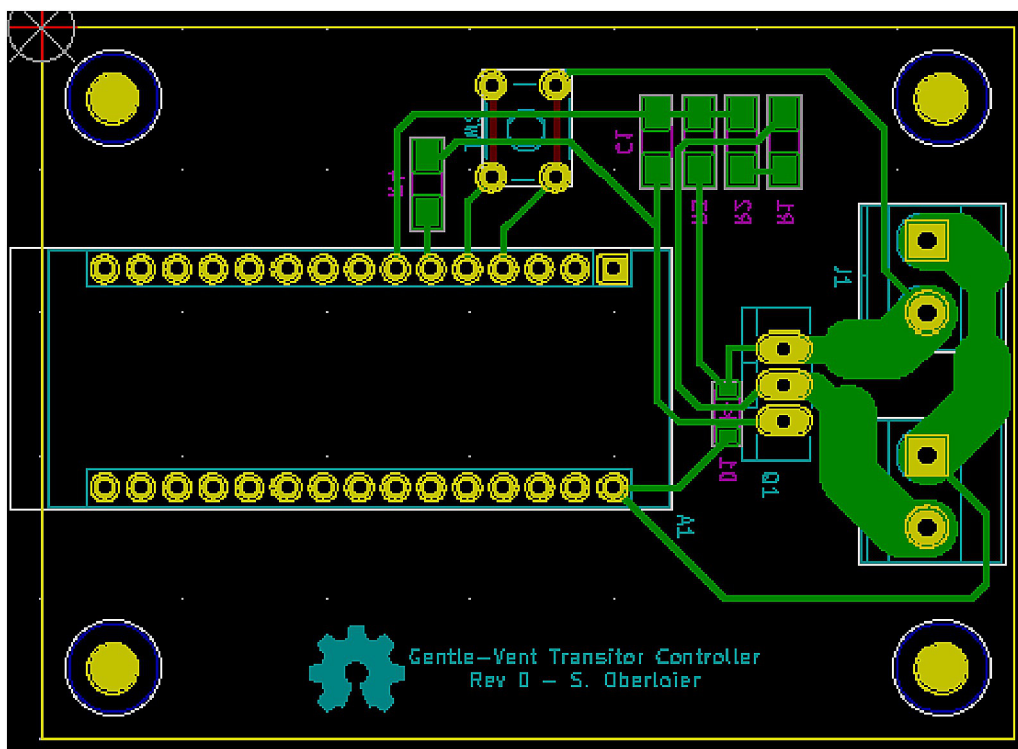

Fig. 7. Rendering of transistor-based controller implemented on a PCB.

Table 6
BOM of transistor-based implementation on a PCB.

Qty	Description	Cost (USD)	URL
1	Copper Clad Board	\$0.69	https://www.amazon.com/dp/B01MCVLDZ/
2	2-position Terminal Blocks	\$0.32	https://www.amazon.com/dp/B01MT4LC0F
2 g	Solder	\$0.17	https://www.amazon.com/dp/B075WB98FJ/
2 ft	Wires	\$0.16	https://www.amazon.com/dp/B07TX6BX47
1	Button	\$0.07	https://www.amazon.com/dp/B01N6GU7TA
4	10 k Resistors	\$0.30	https://www.amazon.com/dp/B0185FIOTA
1	10nF Capacitor	\$0.05	https://www.amazon.com/dp/B07KG3F6M3/
1	1 N4007 Diode	\$0.25	https://www.amazon.com/dp/B00W17LOBO/
1	Arduino Nano	\$3.60	https://www.amazon.com/dp/B07RQ8S1LG

Table 7
Key characteristics of power supplies.

Name	Voltage	Max Current	Cost (USD)	URL
Supply 1	12VDC	8 A	\$17.69	https://www.amazon.com/dp/B07G5BQGYP
Supply 2		5 A	\$15.59	https://www.amazon.com/dp/B073QTNF9F
Supply 3		5 A	\$12.99	https://www.amazon.com/dp/B078RY6YY3
Supply 4		6 A	\$89.99	https://www.amazon.com/dp/B07H8F5HYJ

Firmware

The firmware is written in the Arduino IDE, and has all key parameters easily adjustable. The flow chart of the firmware operation is shown in Fig. 8. The code is relatively simple including spacing and comments is only nine pages. There are 3 pressure level targets that can be toggled through by pressing the button. Additionally, the turn-on pres-

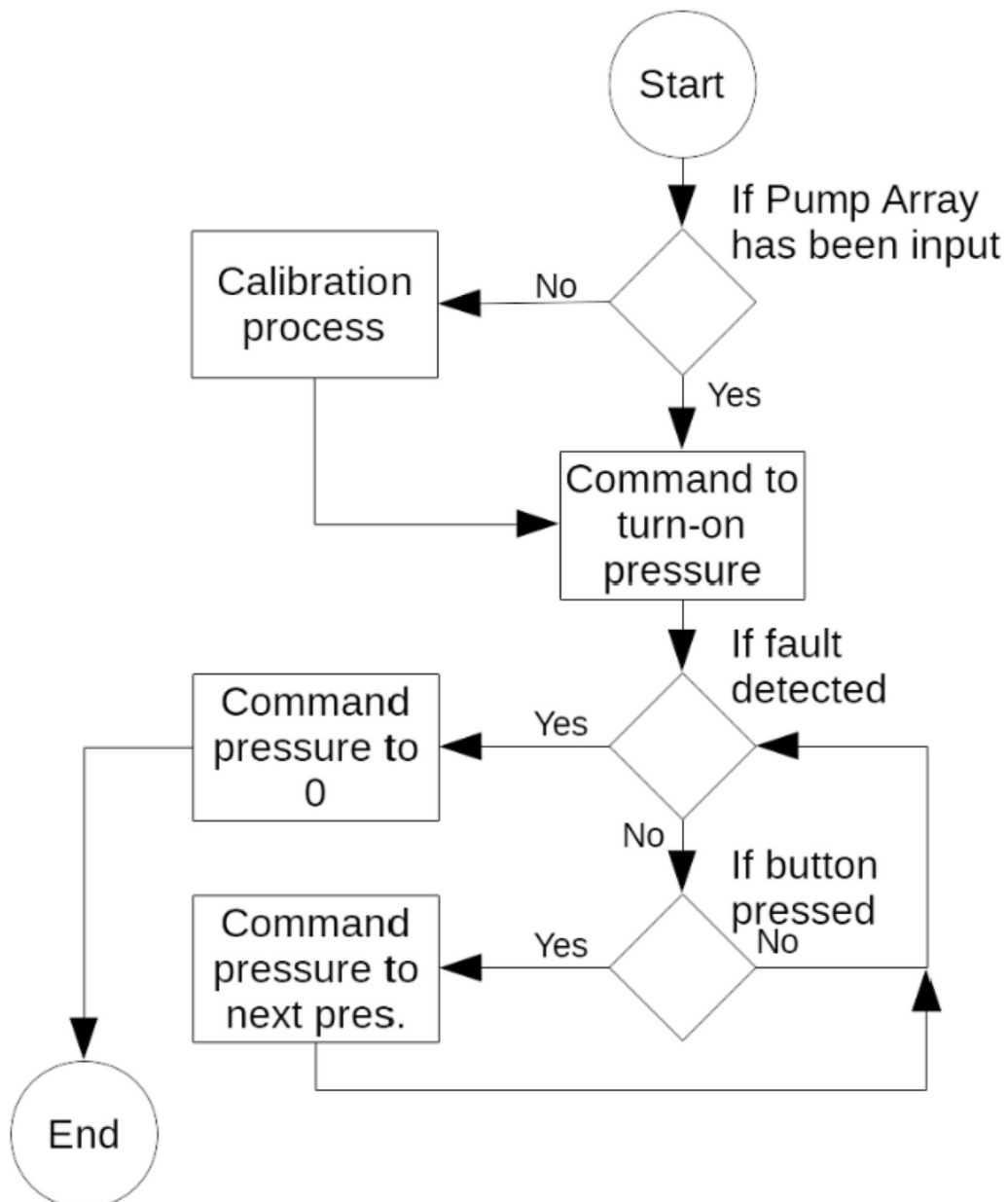

Fig. 8. Flow chart of firmware operation.

sure can be set. Normally the turn-on pressure will be “0”, however, in cases where a button is not available, this pressure should be set to the normal operating pressure.

On start-up, the firmware validates if the calibration array has been input. If the array is not detected, the calibration procedure is triggered in which the pump is driven by varying PWM signals and the user must measure and input the resultant pressure via the serial monitor. Once the calibration procedure has completed, the resultant array will be outputted to the serial monitor, and normal operation will begin. The array must be copied and pasted into the firmware and re-uploaded to the device.

Applications

Use cases

This gentle-vent can be used in cases where a medical professional deems that the patient is unable to intake the required amount of oxygen to supply to the body and brain [50]. This may include patients who get sick and smoke, have atelectasis, or any respiratory problem. When a patient shows that they are having difficulty breathing, the medical professional typically recommends introducing a ventilator to aide in the breathing process. A gentle-vent may also be used during surgery when a patient undergoes anesthesia [36].

There is an alternative to the tube insert that allow for a non-invasive option, especially those that are vulnerable to the damage from this. This can also be of high impact for those in low- and middle-income countries, where this was done through the use of a nasal mask and the non-invasive mask counterpart [51]. This non-invasive approach is made available through readily-available materials and can be easily accessed by many all over the world.

Reuse potential and adaptability

This design is among many ways the use of engineering is being use to battle COVID-19 [39,52-55]. The open source nature of this family of devices empowers the user to make adaptations, which is line with many other areas of applications, for example, Arduino enabled data acquisition, monitoring and control [39,56,57]. The device could be for example. Upgraded to include a graphical user interface (GUI) for visualizing the main parameters of the device. Also it would be straight forward to replace the typical AC adapter and have the device be cordless using an embedded power supply. So thus, for example, if it were battery powered a remaining breathing percentage or time could be displayed.

The gentle-vent is also highly reusable. If the device is used on multiple patients, the pump and hose should be sanitized with ethylene oxide if made of silicone materials [58,59] or steam for fluoroplastics [60]. As 3-D printed components are very porous [61], they can be hard to sanitize fully, and therefore a new mouthpiece should be used for each patient unless printed in high-temperature plastics that can be sterilized with heat [62].

The gentle-vent design does not involve destructive use of the reclaimed components, and therefore many of them can again be repurposed after the constructed device is no longer needed. This is especially important when it comes to sustainability and usability of the make-up of the gentle-vent. As items are repurposed, the waste of the gentle-vent is reduced, which, in turn, reduces its environmental impact.

The design's simplistic implementation allows for a wide range of components to be utilized. The parametric hose converter allows for the adaption of any hose to any nozzle (Fig. 3).

The most important constraints to select components around is electrical compatibility. The following terms must be met:

- The pump operation voltage must be less than or equal to the voltage of the power supply.
- The pump must draw less current (at the desired pressure) than the power supply's max capacity.
- The switching device must be able to withstand the supply voltage AND the max current.
- The switching device's gate (or coil) must be within the maximum output capability of the microcontroller.

Since microcontrollers current outputs are typically small, it is best to utilize a solid-state switching device, as they can be triggered with small voltages and currents [44].

This hardware can be utilized by:

- Acting as a baseline for a low-cost ventilator design
- Acting as a life support mechanism in cases of extreme scarcity
- Be repurposed as a low-cost pressure controller

Design files summary

All design files are available on OSF [43] under the GNU GPL License, [Table of Specifications](#).

Design File Name	File Type	Open Source License	Location of the File
Electrical/SSR/	KiCAD PCB	GPL 3.0	https://doi.org/10.17605/OSF.IO/UV9MZ
Electrical/SSR/Gerbers	PCB Fab Files	GPL 3.0	https://doi.org/10.17605/OSF.IO/UV9MZ
Electrical/Transistor/	KiCAD PCB	GPL 3.0	https://doi.org/10.17605/OSF.IO/UV9MZ
Electrical/Transistor/Gerbers	PCB Fab Files	GPL 3.0	https://doi.org/10.17605/OSF.IO/UV9MZ
Firmware/GentleVent.ino	Arduino Firmware	GPL 3.0	https://doi.org/10.17605/OSF.IO/UV9MZ
Mechanical/Adaptor.scad	OpenSCAD	GPL 3.0	https://doi.org/10.17605/OSF.IO/UV9MZ
Mechanical/Mouthgaurd.stl	STL	GPL 3.0	https://doi.org/10.17605/OSF.IO/UV9MZ

- **Electrical/SSR/**: KiCAD PCB design files for an SSR based Gentle-Vent.
- **Electrical/SSR/Gerbers**: Gerber files for PCB manufacturing via either mill or commercial manufacturer
- **Electrical/Transistor/**: KiCAD PCB design files for an Transistor based Gentle-Vent.
- **Electrical/Transistor/Gerbers**: Gerber files for PCB manufacturing via either mill or commercial manufacturer
- **Firmware/GentleVent.ino**: The generic and default Arduino-based firmware for the Gentle-Vent
- **Mechanical/Adaptor.scad**: An OpenSCAD parametric tube adaptor
- **Mechanical/Mothgaurd.stl**: A 3D-printable mouthpiece

Bill of materials summary

Note that the bill of material may consist of various permutations across Tables 1–7 (with ample room for substitutions). Therefore, a BOM for the most inexpensive iteration will be given as a condensed example.

Designator	Component	Number	Cost per unit - currency	Total cost - currency	Source of materials	Material type
Pump 1	12 V Vacuum Pump	1	\$11.99	\$11.99	https://www.amazon.com/dp/B07F3QF4B4	Mechanical Component
Controller 1	Arduino Nano	1	\$3.60	\$3.60	https://www.amazon.com/dp/B07RQ8S1LG	Electrical Component
Switch 1	TIP 120 Transistor	1	\$0.44	\$0.44	https://www.amazon.com/dp/B07LG2C3MY	Electrical Component
Perf-Board Based	Perf-board	1	\$0.29	\$0.29	https://www.amazon.com/dp/B07FFDFLZ3	Electrical Component
Perf-Board Based	Solder	2 g	\$0.08 / g	\$0.17	https://www.amazon.com/dp/B075WB98FJ/	Electrical Component
Perf-Board Based	Wires	2 ft	\$0.08 / ft	\$0.16	https://www.amazon.com/dp/B07TX6BX47	Electrical Component
Perf-Board Based	Button	1	\$0.07	\$0.07	https://www.amazon.com/dp/B01N6GU7TA	Electrical Component
Perf-Board Based	10 k Resistors	4	\$0.07	\$0.30	https://www.amazon.com/dp/B0185FIOTA	Electrical Component
Perf-Board Based	10nF Capacitor	1	\$0.05	\$0.05	https://www.amazon.com/dp/B07KG3F6M3/	Electrical Component
Perf-Board Based	1 N4007 Diode	1	\$0.25	\$0.25	https://www.amazon.com/dp/B00W17LOBO/	Electrical Component
Perf-Board Based	Perf-board	1	\$0.29	\$0.29	https://www.amazon.com/dp/B07FFDFLZ3	Electrical Component
Supply 3	12 V 5A DC Supply	1	\$12.99	\$12.99	https://www.amazon.com/dp/B078RY6YY3	Electrical Component
MouthPiece	Mouth piece	1	\$0.21	\$0.21	https://doi.org/10.17605/OSF.IO/UV9MZ	PLA
Tube	6 ft CPAP Tube	1	\$6.99	\$6.99	https://www.amazon.com/dp/B087BC5PLK/	Mechanical Component

Build instructions

Mechanical construction

The mouthpiece can either be 3-D printed (Fig. 2), or be improvised by cutting from a soda bottle (Fig. 9).

Makers should connect the mouthpiece to the output of the pump via an available tube. If the available tube does not fit on the mouthpiece or pump, the adaptor (Fig. 3) can be customized in OpenSCAD and 3-D printed. Alternatively, Teflon tape can be wrapped around the exterior of a surface to mate the components.

Electrical construction

Users should construct the electronics in the best possible form following the rules above. A maker should cut and strip the connector of the power supply and connect it to the power input of the electronics. Finally, the maker cuts and strips the connector of the pump and connects it to the power output of the electronics.

An example of a completed gentle-vent is shown in Fig. 10.

Availability of materials and methods

This design is specified to be executed using common readily-available materials. The hardware configurations explored in this paper are not the only components that can be used to implement this design. Components can be salvaged from existing devices, such as a power supply from a television, a pump from an air mattress, a hose from a vacuum cleaner, etc.

When considering global availability, the microcontroller and switching device are the least-available components. Almost any microcontroller development board can be used to control the switch. Given moderate programming knowledge, the Arduino firmware can be converted over to work with other types of microcontrollers. Switches (specifically transistors) can be salvaged from old electronics [63]. The TIP120 is commonly used in many devices.



Fig. 9. A heavily improvised mouthpiece.

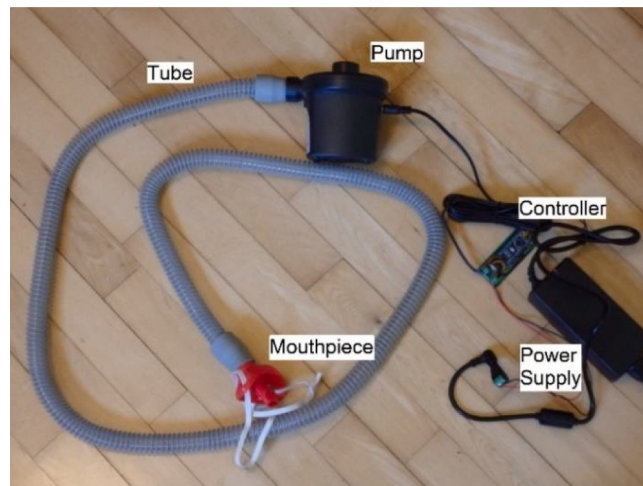

Fig. 10. A completed permutation of the gentle-vent system.

Ease of build

Once all components are procured, assembly is approximately 30 min. If the electronics are soldered together in a dead-bug style or on perforated board, the design will take an additional 30 min to assemble.

Programming the Arduino Nano takes minimal programming knowledge to modify parameters for whatever pump is used. Basic measurement skills are need for calibration.

Operating software and peripherals

The firmware is programmed around the Arduino Nano – which has limited functionality compared to the Arduino family of development boards [34]. Therefore, the firmware should be suitable to run on nearly anything that can be programmed by the Arduino IDE.

Dependencies

Besides for the reliance on the Arduino IDE (which is an open source tool [34] the project has no dependencies. The project is inspired and compatible with an existing design available on Github [40].

Operation instructions

Safety

The device has no overcurrent protection. The pump should be specified such that it draws less current than the power supply so that the gentle-vent can rely on the power supply's built-in current protection.

Proper calibration of the device is paramount to the safety of the target patient's lungs, as there is a risk of permanent lung damage if the pump outputs a pressure greater than 12.5 InH₂O [46]. This upper limit must be carefully followed.

Although, this is a emergency device, the gentle-vent should only be used under the supervision of a trained medical professional, who has verified that the tested and calibrated performance of the device poses no risk to the patient and the patient should be under intermittent (once an hour) observation [47]. The authors and publisher assume no liability for users developing their own version(s) of the device.

An important note of caution: When implementing any of the versions of the gent-vent discussed in this article, it is important to critically evaluate the reliability and safety of the design on a case by case basis. While many of the versions of the designs have been extensively tested and verified, others are not and it is likely that in an emergency situation the user may only have untested combinations of components available. While this is important in all aspects of free and open hardware, it becomes imperative when considering medical applications and those to be used on humans. The user should consider this for research and include careful reference to regulations on control software when it is applicable [63]. It is highly probable, that the use of these designs in a clinical setting is prohibited by local regulations. In the, US, for example the fab-

rication of any medical device, even those approved by the FDA, must be manufactured in a facility that is also FDA approved. In an emergency situation it is unlikely to have access to such facilities.

Calibration

One end of the hose is connected to the pump outlet, while the other is suspended in air. ~ 500 ml of water are poured into the hose to create a manometer (Fig. 11). The base level (at atmosphere) is marked, and then the firmware will begin sweeping through PWM values. The height of the water is measured and entered into the firmware at each PWM, and the resultant PWM – pressure curve is generated.

A typical response should look like Fig. 12. Additionally, an open source VentMon [48] can be used to validate measurements (Fig. 13).

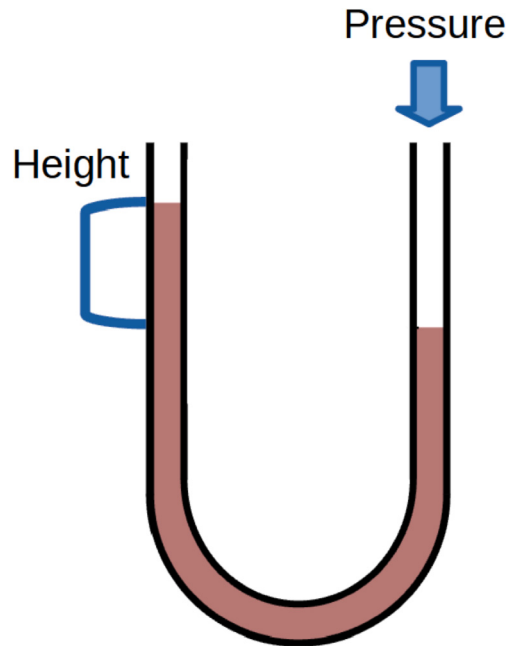

Fig. 11. A simplified illustration of the setup used to find the PWM-pressure calibration curve.

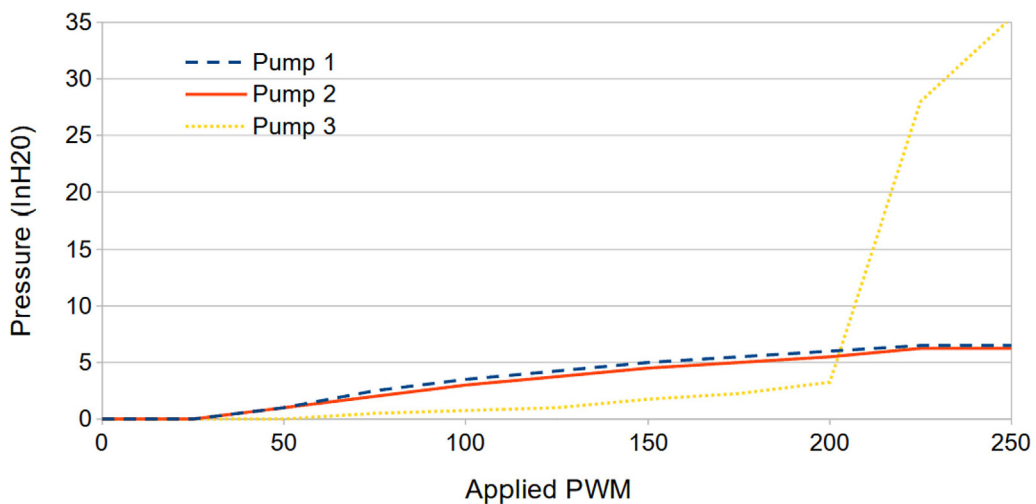

Fig. 12. Pressure responses of each pump during calibration.

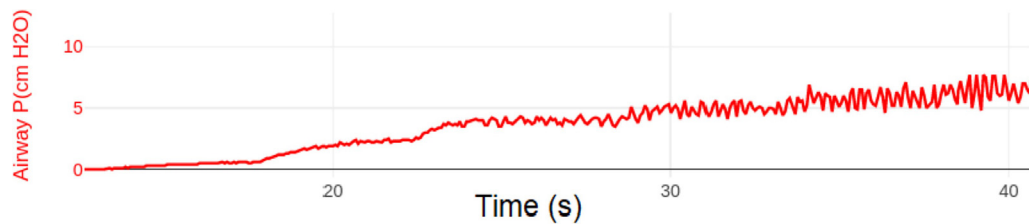

Fig. 13. Typical pressure measurements during calibration on VentMon.

Risks

There are risks associated with the use of any ventilator including: pneumonia, from excessive use. Blood clot or bed sores can also occur if one does not move enough from lying in bed or sitting in a wheel chair. Fluid buildup in alveolar sacs can be produced when on a ventilator for an extended period of time. The strength of the patient's diaphragm weakens when on the ventilator from the lessened use of manual breathing. The vocal cords can also sustain damage from the tubing of the ventilator, leading to hoarseness and trouble speaking. Damage primarily occurs in developing children [36].

Operation instructions

Assuming the device has been calibrated properly the following steps must be carried out.

1. Place the mouthpiece firmly in / around the patient's mouth.
2. Plug in the power supply.
3. Depending on the configuration of the firmware, the mode button may need to be pressed to initialize a pre-configured flow. Use a laptop to verify the pressure mode via USB.
4. Once an hour, perform a wellness check on the patient [47].
5. To remove – Unplug the supply, then remove the mouthpiece. Continue to monitor the patient even after the device is removed.

Validation and characterization

The calibration procedure effectively validates the general function of the device. The only remaining test is to validate the endurance of the gentle-vent, which is the primary limitation to this study. As the pump heats up, the pressure may vary [44]. In order to measure the pump for consistency over time, the pump is run continuously for 2 h, with pressure measured in 10-minute increments. All permutations of Tables 1 and 6 tested successfully. An example run can be seen in Fig. 14. In some cases of prolonged use, the pump and supply may resonate causing the Arduino to reset. If this occurs, the resonance spikes can be removed by adding a 10uF capacitor (or greater) to the supply input to the control circuit.

Additionally, the VentMon paired with a resuscitator bag [49] can be used to demonstrate operation on a set of simulated lungs as shown in Fig. 15.

Each gentle-vent permutation that was tested was able to accurately hold a desired setpoint for at least 2 h. The most rudimentary implementation using found mechanical components and perf-board can cost as low as US\$37.80, and can potentially be less expensive with resourceful electronics scavenging. The proposed gentle-vent framework can be used in periods of scarcity when no other options are available.

Future work includes implementing the design using controllers other than the Arduino, along with different pumps, hoses, switches and power supply combinations. In addition, the effectiveness of the device for aiding COVID-19 and other patients can be tested and documented.

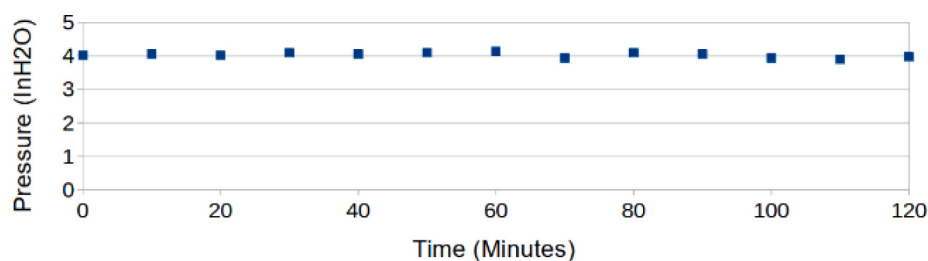

Fig. 14. An example 2-hour stress test with Pump 1 and Supply 1.

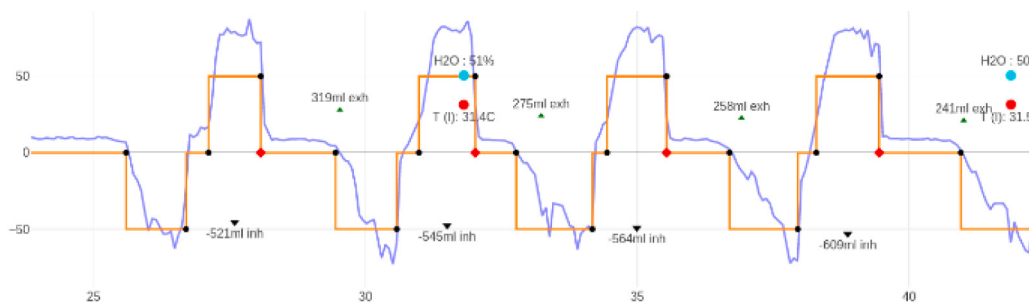

Fig. 15. Illustrated example of pressure measurements and rate recognition taken with the VentMon. Blue line – airway pressure; Orange line – extrapolated exhale / inhale; Red dot – temperature; Blue dot – H₂O content. (For interpretation of the references to colour in this figure legend, the reader is referred to the web version of this article.)

Conclusions

The COVID-19 pandemic created temporary shortages of medical equipment like ventilators throughout the world. Recent medical research also indicates a gentle ventilation may be more appropriate for many patients. This article detailed the design of an open source gentle ventilator (gentle-vent) framework that can be used in periods of scarcity when no other options are available. The system utilizes a wide range of commonly available components that are combined using basic electronics skills to achieve the desired end product although it is not a medical device. The firmware is programmed in the Arduino IDE using any Arduino compatible microcontroller. The main function of the gentle-vent is to generate a calibrated pressure wave at the pump to provide support to the patient's breathing. Each gentle-vent permutation was tested using a DIY manometer as it would be utilized in the field in low-resource settings. These measurements were also verified with an open source VentMon. All permutations were able to accurately hold a desired setpoint for at least 2 h. The most rudimentary implementation using found mechanical components and perf-board costs less than \$40. The results indicate that an open source approach can be used to make breathing support accessible in most contexts.

Ethics statements

All ethical guidelines were followed and no humans or animals were tested in this work.

CRediT authorship contribution statement

S. Oberloier: Conceptualization, Methodology, Software, Writing – original draft. **N. Gallup:** Investigation, Writing – original draft. **J.M. Pearce:** Conceptualization, Writing – review & editing, Supervision.

Declaration of Competing Interest

The authors declare that they have no known competing financial interests or personal relationships that could have appeared to influence the work reported in this paper.

Acknowledgments

This research was supported by the Witte and Thompson Endowments.

References

- [1] World Health Organization, Critical preparedness, readiness and response actions for COVID-19: interim guidance, World Health Organization, 2020.
- [2] L. Rubinson, F. Vaughn, S. Nelson, S. Giordano, T. Kallstrom, T. Buckley, T. Burney, N. Hupert, R. Mutter, M. Handrigan, K. Yeskey, N. Lurie, R. Branson, Mechanical ventilators in US acute care hospitals, *Disaster Med. Public Health Preparedness* 4 (3) (2010) 199–206.
- [3] J. Miller, Germany, Italy rush to buy life-saving ventilators as manufacturers warn of shortages. Reuters. 2020. <https://www.reuters.com/article/us-health-coronavirus-draegerwerk-ventil-idUSKBN210362>
- [4] E. Livingston, A. Desai, M. Berkwits, Sourcing personal protective equipment during the COVID-19 pandemic, *JAMA* 323 (19) (2020) 1912, <https://doi.org/10.1001/jama.2020.5317>.
- [5] M.L. Ranney, V. Griffith, A.K. Jha, Critical Supply Shortages – The Need for Ventilators and Personal Protective Equipment during the Covid-19 Pandemic, *N. Engl. J. Med.* 382 (18) (2020) e41, <https://doi.org/10.1056/NEJMp2006141>.
- [6] WHO, Shortage of personal protective equipment endangering health workers worldwide [WWW Document], 2020. URL <https://www.who.int/news-room/detail/03-03-2020-shortage-of-personal-protective-equipment-endangering-health-workers-worldwide> (accessed 4.22.20).
- [7] J.S. Srail, M. Kumar, G. Graham, W. Phillips, J. Tooze, S. Ford, P. Beecher, B. Raj, M. Gregory, M.K. Tiwari, B. Ravi, A. Neely, R. Shankar, F. Charnley, A. Tiwari, Distributed manufacturing: scope, challenges and opportunities, *Int. J. Prod. Res.* 54 (23) (2016) 6917–6935.
- [8] A. Laplume, G.C. Anzalone, J.M. Pearce, Open-source, self-replicating 3-D printer factory for small-business manufacturing, *Int. J. Adv. Manuf. Technol.* 85 (1–4) (2016) 633–642.

- [9] M. Stacey, The FAB LAB network: A global platform for digital invention, education and entrepreneurship, *Innov.: Technol. Governance Global* 9 (1-2) (2014) 221–238.
- [10] D.J. Byard, A.L. Woern, R.B. Oakley, M.J. Fiedler, S.L. Snabes, J.M. Pearce, Green fab lab applications of large-area waste polymer-based additive manufacturing, *Addit. Manuf.* 27 (2019) 515–525.
- [11] R.E. DeVor, S.G. Kapoor, J. Cao, K.F. Ehmann, Transforming the landscape of manufacturing: distributed manufacturing based on desktop manufacturing (DM) 2, *J. Manuf. Sci. Eng.* 134 (4) (2012).
- [12] B.T. Wittbrodt, A.G. Glover, J. Laureto, G.C. Anzalone, D. Oppliger, J.L. Irwin, J.M. Pearce, Life-cycle economic analysis of distributed manufacturing with open-source 3-D printers, *Mechatronics* 23 (6) (2013) 713–726.
- [13] E.E. Petersen, J. Pearce, Emergence of home manufacturing in the developed world: Return on investment for open-source 3-D printers, *Technologies* 5 (1) (2017) 7.
- [14] J. Gwamuri, B.T. Wittbrodt, N.C. Anzalone, J.M. Pearce, Reversing the trend of large scale and centralization in manufacturing: The case of distributed manufacturing of customizable 3-D-printable self-adjustable glasses, *Challenges Sustain.* 2 (1) (2014) 30–40.
- [15] J. Pearce, Distributed manufacturing of open-source medical hardware for pandemics, *J. Manuf. Mater. Process.* 4 (2) (2020) 49.
- [16] J. Nguyen, K. Kesper, G. Krälling, C. Birk, P. Mross, N. Hofeditz, J. Höchst, P. Lampe, A. Penning, B. Leutenecker-Twelsiek, C. Schindler, H. Buchenauer, D. Geisel, C. Sommer, R. Henning, P. Wallot, T. Wiesmann, B. Beutel, G. Schneider, E. Castro-Camus, M. Koch, Can CPAP Machines Be Repurposed to Solve the Ventilator Shortage?, preprint (2020), <https://doi.org/10.21203/rs.3.rs-83143/v1>.
- [17] General Motors, First General Motors-Ventec Critical Care V+Pro Ventilators Ready for Delivery, 2020. <https://media.gm.com/media/us/en/gm/home.detail.html/content/Pages/news/us/en/2020/apr/0414-coronavirus-update-12-kokomo.html>
- [18] Ford to Produce 50,000 Ventilators in Michigan in Next 100 Days; Partnering with GE Healthcare Will Help Coronavirus Patients, 2020. Ford Media Center. <https://media.ford.com/content/fordmedia/fna/us/en/news/2020/03/30/ford-to-produce-50-000-ventilators-in-michigan-in-next-100-days.html>
- [19] R. Baldwin, Tesla's Ventilator Design Has a Long Road before Helping Patients. Hearst Autos, Inc., 2020. <https://www.caranddriver.com/news/a32071189/tesla-ventilator-design-coronavirus-details/>
- [20] J.M. Pearce, A review of open source ventilators for COVID-19 and future pandemics. *F1000Res* 9 (2020) 218. <https://doi.org/10.12688/f1000research.22942.2>
- [21] COVID-19 Ventilator Projects and Resources with FAQs, 2020. Public Invention. <https://github.com/PubInv/covid19-vent-list>
- [22] A. Petsiuk, N.G. Tanikella, S. Dertinger, A. Pringle, S. Oberloier, J. Pearce, RepRapable Automated Open Source Bag Valve Mask-Based Ventilator, *HardwareX* 8 (2020) e00131, <https://doi.org/10.1016/j.ohx.2020.e00131>.
- [23] O. Garmendia, M.A. Rodríguez-Lazaro, J. Otero, P. Phan, A. Stoyanova, A.T. Dinh-Xuan, D. Gozal, D. Navajas, J.M. Montserrat, R. Farré, Low-cost, easy-to-build noninvasive pressure support ventilator for under-resourced regions: open source hardware description, performance and feasibility testing, *Eur. Respir. J.* 55 (6) (2020) 2000846, <https://doi.org/10.1183/13993003.00846-202010.1183/13993003.00846-2020.Supp110.1183/13993003.00846-2020.Shareable1>.
- [24] J. Zuckerberg, M. Shaik, K. Widmeier, T. Kilbaugh, T.D. Nelin, A lung for all: novel mechanical ventilator for emergency and low-resource settings, *Life Sci.* 257 (2020) 118113, <https://doi.org/10.1016/j.lfs.2020.118113>.
- [25] A. Faryami, C.A. Harris, Open-source 3D printed Ventilation Device. *bioRxiv* (2020).
- [26] J. LaChance, T.J. Zajdel, M. Schottdorf, J. Saunders, S. Dvali, L. Seirup, C. Marshall, D.A. Notterman, D.J. Cohen, PVP1—The People's Ventilator Project: A fully open, low-cost, pressure-controlled ventilator, *medRxiv* (2020).
- [27] A. Christou, M. Ntagios, A. Hart, R. Dahiya, GlasVent—The Rapidly Deployable Emergency Ventilator, *Glob. Challenges* 4 (12) (2020) 2000046, <https://doi.org/10.1002/gch2.v4.1210.1002/gch2.202000046>.
- [28] K. Moore, How COVID-19 Supply Chain Issues Are Impacting Retailers With Products Made In The US [WWW Document]. *Forbes*, 2020. URL <https://www.forbes.com/sites/kaleighmoore/2020/04/30/how-covid-19-supply-chain-issues-are-impacting-retailers-with-products-made-in-the-us/> (accessed 7.8.20).
- [29] A. Shokrani, E.G. Loukaides, E. Elias, A.J.G. Lunt, Exploration of alternative supply chains and distributed manufacturing in response to COVID-19; a case study of medical face shields, *Mater. Des.* 192 (2020) 108749, <https://doi.org/10.1016/j.matdes.2020.108749>.
- [30] B.R. Hubbard, J.M. Pearce, Conversion of self-contained breathing apparatus mask to open source powered air-purifying particulate respirator for fire fighter COVID-19 response, *HardwareX* 8 (2020) e00129, <https://doi.org/10.1016/j.ohx.2020.e00129>.
- [31] L. Gattinoni, S. Coppola, M. Cressoni, M. Busana, S. Rossi, D. Chiumello, COVID-19 Does Not Lead to a “Typical” Acute Respiratory Distress Syndrome, *Am. J. Respir. Crit. Care Med.* 201 (10) (2020) 1299–1300, <https://doi.org/10.1164/rccm.202003-0817LE>.
- [32] Do COVID-19 Vent Protocols Need a Second Look? [WWW Document], 2020. Medscape. URL <http://www.medscape.com/viewarticle/928156> (accessed 7.8.20).
- [33] Is Protocol-Driven COVID-19 Ventilation Doing More Harm Than Good? [WWW Document], 2020. Medscape. URL <http://www.medscape.com/viewarticle/928236> (accessed 7.8.20).
- [34] Arduino - ArduinoNano [WWW Document], 2020. URL <https://www.arduino.cc/en/Guide/ArduinoNano> (accessed 1.23.20).
- [35] Pérez-Peña, Richard, Why Some Hospitals Lack the Oxygen to Keep Patients Alive, *The New York Times*, May 4, 2021, sec. World. <https://www.nytimes.com/2021/05/04/world/oxygen-shortage-covid.html>.
- [36] NIH. Ventilator/Ventilator Support <https://www.nhlbi.nih.gov/health-topics/ventilatorventilator-support>.
- [37] S. Oberloier, J.M. Pearce, General design procedure for free and open-source hardware for scientific equipment, *Designs* 2 (1) (2018) 2.
- [38] <https://www.oshwa.org/definition/>
- [39] M. Salmi, J.S. Akmal, E. Pei, J. Wolff, A. Jaribion, S.H. Khajavi, 3D Printing in COVID-19: Productivity Estimation of the Most Promising Open Source Solutions in Emergency Situations, *Appl. Sci.* 10 (11) (2020) 4004.
- [40] Lee, J., 2020. Low-Cost Open-Source Ventilator-ish Device or PAPR. <https://github.com/jcl5m1/ventilator>
- [41] Creativity3DPrinting / Ender-3 <https://github.com/Creativity3DPrinting/Ender-3>
- [42] ultimaker.com, “Ultimaker Cura: Powerful, Easy-to-Use 3D Printing Software.” Accessed June 8, 2021. <https://ultimaker.com/software/ultimaker-cura>.
- [43] Pearce, Joshua M, Shane Oberloier, and Nicki Gallup. 2021. “OS Gentle Ventilation.” OSF. June 3. <https://doi.org/10.17605/OSF.IO/UV9MZ>
- [44] P. Scherz, S. Monk, *Practical electronics for inventors*, 4th ed., McGraw-Hill Education, New York, 2016.
- [45] S. Oberloier, J.M. Pearce, Belt-Driven Open Source Circuit Mill Using Low-Cost 3-D Printer Components, *Inventions* 3 (3) (September 2018) 64, <https://doi.org/10.3390/inventions3030064>.
- [46] Williams, Elizabeth C., Gabriel C. Motta-Ribeiro, Marcos F. Vidal Melo, Driving Pressure and Transpulmonary Pressure: How Do We Guide Safe Mechanical Ventilation? *Anesthesiology* 131(1) (2019) 155–63. <https://doi.org/10.1097/ALN.0000000000002731>.
- [47] Williams, Lesley M., Sandeep Sharma, Ventilator Safety, in: StatPearls. Treasure Island (FL): StatPearls Publishing, 2021. <http://www.ncbi.nlm.nih.gov/books/NBK526044/>.
- [48] R.L. Read, L. Clarke, G. Mulligan, VentMon: An open source inline ventilator tester and monitor, *HardwareX* 9 (2021) e00195, <https://doi.org/10.1016/j.ohx.2021.e00195>.
- [49] “Amazon.Com: PVC Adult Tool Bag Resuscitator Bag for First Aid Training, CPR Manual Tool Kit Artificial Device: Health & Personal Care.” Accessed June 8, 2021. <https://www.amazon.com/Resuscitator-Training-Manual-Artificial-Device/dp/B0885ZT812/>
- [50] K. Gelles, G. Petras, How ventilators work and why COVID-19 patients need them to survive coronavirus, *USA Today* (2020). <https://www.usatoday.com/in-depth/news/2020/04/10/coronavirus-ventilator-how-works-why-covid-19-patients-need/2942996001/>.
- [51] O. Garmendia, M.A. Rodríguez-Lazaro, J. Otero, P. Phan, A. Stoyanova, A.T. Dinh-Xuan, D. Gozal, D. Navajas, J.M. Montserrat, R. Farré, *Eur Respir J.* 55. Low-Cost, Easy-to-Build Noninvasive Pressure Support Ventilator for under-Resourced Regions: Open Source Hardware Description, Performance

- Feasibility Test. 55 (6) (2020) 2000846, <https://doi.org/10.1183/13993003.00846-202010.1183/13993003.00846-2020.Supp110.1183/13993003.00846-2020.Shareable1>.
- [52] B. El Majid, A. El Hammoumi, S. Motahhir, A. Lebbadi, A. El Ghzizal, Preliminary design of an innovative, simple, and easy-to-build portable ventilator for COVID-19 patients, *Euro-Mediterranean J. Environ. Integr.* 5 (2) (2020) 1–4.
- [53] S. Hussain, M.J.M. Cheema, S. Motahhir, M.M. Iqbal, A. Arshad, M.S. Waqas, M. Usman Khalid, S. Malik, Proposed design of walk-through gate (WTG): mitigating the effect of COVID-19, *Appl. Syst. Innov.* 3 (3) (2020) 41, <https://doi.org/10.3390/asi3030041>.
- [54] B. El Majid, S. Motahhir, A. El Hammoumi, A. Lebbadi, A. El Ghzizal, Preliminary design of a smart wristband disinfectant to help in covid-19 fight, *Inventions* 5 (3) (2020) 32.
- [55] A. Richterich, When open source design is vital: critical making of DIY healthcare equipment during the COVID-19 pandemic, *Health Sociol. Rev.* 29 (2) (2020) 158–167.
- [56] H.K. Kondaveeti, N.K. Kumaravelu, S.D. Vanambathina, S.E. Mathe, S. Vappangi, A systematic literature review on prototyping with Arduino: Applications, challenges, advantages, and limitations, *Comp. Sci. Rev.* 40 (2021) 100364, <https://doi.org/10.1016/j.cosrev.2021.100364>.
- [57] G. Chiesa, D. Di Vita, A. Ghadirzadeh, A.H. Muñoz Herrera, J.C. Leon Rodriguez, A fuzzy-logic IoT lighting and shading control system for smart buildings, *Autom. Constr.* 120 (2020) 103397, <https://doi.org/10.1016/j.autcon.2020.103397>.
- [58] G.C.C. Mendes, T.R.S. Brandão, C.L.M. Silva, Ethylene Oxide Sterilization of Medical Devices: A Review, *Am. J. Infect. Control* 35 (9) (2007) 574–581.
- [59] J. Knutsson, C. Priwin, A.-C. Hessel-Söderman, A. Rosenblad, M. von Unge, A Randomized Study of Four Different Types of Tympanostomy Ventilation Tubes – Full-Term Follow-Up, *Int. J. Pediatr. Otorhinolaryngol.* 107 (2018) 140–144, <https://doi.org/10.1016/j.ijporl.2018.02.012>.
- [60] X. Wang, L. Zhao, J.Y.H. Fuh, H.P. Lee, Effect of Porosity on Mechanical Properties of 3D Printed Polymers: Experiments and Micromechanical Modeling Based on X-Ray Computed Tomography Analysis, *Polymers* 11 (7) (2019), <https://doi.org/10.3390/polym11071154>.
- [61] N.G. Skrzypczak, N.G. Tanikella, J.M. Pearce, Open source high-temperature RepRap for 3-D printing heat-sterilizable PPE and other applications, *HardwareX* 8 (2020) e00130, <https://doi.org/10.1016/j.ohx.2020.e00130>.
- [62] How to Salvage Useful Components from Old Electronics - Electronic Products [WWW Document], 2021 URL https://www.electronicproducts.com/Electromechanical_Components/Motors_and_Controllers/How_to_Salvage_Useful_Components_from_Old_Electronics.aspx# (accessed 7.8.20).
- [63] J. Twomey, Know Your Regulations Before You Design Medical Electronics <https://www.electronicdesign.com/power-management/article/21798672/know-your-regulations-before-you-design-medical-electronics> (accessed 2021 -10 -08).

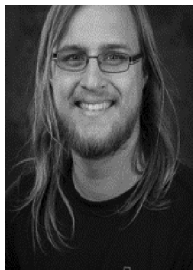

S. Oberloier is a Ph.D. Candidate at Michigan Technological University. His research encompasses many different open source and appropriate designs. His teaching interests range from robotics to digital design and electrical engineering fundamentals. Before his time at MTU, he completed his undergraduate degree at Saginaw Valley State University, where he devoted much of his time to the FSAE race team. Additionally, Shane has worked at Wineman Technology Incorporated developing National Instruments data acquisition systems, and at Interactive Aerial designing power electronics and control boards for UAVs.



N. Gallup is currently studying for her undergraduate degree in Biomedical and Mechanical Engineering at Michigan Technological University in Houghton, Michigan. Since 2018, she has been conducting research in the Michigan Tech Open Sustainability Technology Lab. She has received the DeVlieg Foundation Internship, the Portage Health Foundation Internship, and the Pavlis Honors College Scholarship to continue her research efforts. She graduates with her B.S. in Biomedical Engineering and Mechanical Engineering in May 2022.



J.M. Pearce received his Ph.D. in Materials Engineering from the Pennsylvania State University. He currently is the John M. Thompson Chair in Information Technology and Innovation cross-appointed in the Richard Ivey School of Business, the Thompson Centre of Engineering Leadership & Innovation and the Department of Electrical and Computer Engineering at Western University. As the Richard Witte Professor of Materials Science and Engineering and a Professor cross-appointed in the Department of Electrical & Computer Engineering at Michigan Tech he directed the Michigan Open Sustainability Technology Research Group. His research concentrates on the use of open source appropriate technology to find collaborative solutions to problems in sustainability and poverty reduction. His research spans areas of electronic device physics and materials engineering of solar photovoltaic cells, and RepRap 3-D printing, but also includes applied sustainability and energy policy. He is the author of the Open-Source Lab: How to Build Your Own Hardware and Reduce Research Costs and Create, Share, and Save Money Using Open-Source Projects.