

# Genetic analysis of Brugada syndrome and congenital long-QT syndrome type 3 in the Chinese

Peng Liang, Wenling Liu<sup>1</sup>, Cuilan Li<sup>1</sup>, Wuhua Tao<sup>2</sup>, Lei Li<sup>1</sup>, Dayi Hu<sup>1</sup>

Heart Center, Beijing Chuiyangliu Hospital, Beijing, <sup>1</sup>Department of Cardiology, Peking University People's Hospital, Beijing, <sup>2</sup>Department of Cardiology, Fudan University Jinshan Hospital, Shanghai, PRC

**Address for correspondence:** Dr. Peng Liang, Heart Center,

Beijing Chuiyangliu Hospital Beijing-100 022, PRC. E-mail: lp\_wings@163.com.

Dr. Dayi Hu, Department of Cardiology, Peking University People's Hospital, Beijing-100044, PRC.

E-mail: dayi.hu@medmail.com.cn

## ABSTRACT

**Background:** Brugada syndrome and congenital long-QT syndrome (LQTS) type 3 (LQT3) are 2 inherited conditions of abnormal cardiac excitability characterized clinically by an increased risk of ventricular tachyarrhythmias. SCN5A gene that encodes the cardiac sodium channel  $\alpha$  subunit is responsible for the 2 diseases, and more work is needed to improve correlations between SCN5A genotypes and associated clinical syndromes. **Methods and Results:** Four patients diagnosed as having Brugada syndrome, 9 patients suspected to have Brugada syndrome, and 3 LQTS patients suspected to be LQT3 without mutations in KCNQ1 and HERG participated in the study. DNA samples from these patients were analyzed using direct sequencing. One patient with Brugada syndrome had 2 novel mutations, V95I and A1649V. The former was identified in the N-terminus of SCN5A and the latter was in the DIVS4/S5 linker of SCN5A. One patient suspected to have Brugada syndrome had a mutation, delF1617, in the DIIS3/S4 linker of SCN5A. A novel mutation in the C-terminus of SCN5A, delD1790, was found in a patient with LQT3. No other mutations of SCN5A were found in the remaining patients. These 4 mutations were not detected in 50 unrelated control subjects. **Conclusions:** Two novel and a reported SCN5A mutations were found in Chinese patients with Brugada syndrome, and a novel SCN5A mutation was found in a Chinese patient with LQT3.

**Key words:** Brugada syndrome, cardiac sodium channel, long-QT syndrome, SCN5A gene mutation

DOI: 10.4103/0975-3583.64437

## INTRODUCTION

Brugada syndrome and congenital long-QT syndrome type 3 (LQT3) are 2 allelic diseases associated with mutations in SCN5A gene that encodes the cardiac sodium channel  $\alpha$  subunit. Brugada syndrome was first described as a clinical entity by Brugada and Brugada in 1992.<sup>[1]</sup> It is characterized by a typical electrocardiogram (ECG) pattern of ST-segment elevation in leads V<sub>1</sub> through V<sub>3</sub>, a complete or incomplete right bundle-branch block (RBBB), and a high incidence of sudden cardiac death in patients with structurally normal hearts. The syndrome is believed to be responsible for at least 4% of all sudden deaths and at least 20% of sudden deaths in patients with structurally normal hearts.<sup>[2]</sup> It is inherited in an autosomal dominant mode and SCN5A gene is an important gene to be linked to the disease. It has been

agreed that patients with the syndrome who have experienced syncope episodes or been resuscitated from cardiac arrest should receive an implantable cardioverter defibrillator (ICD).<sup>[3]</sup> However, controversies exist in the treatment of asymptomatic patients who might become symptomatic and develop sudden cardiac death resulting from the first attack of ventricular fibrillation (VF).

Long-QT syndrome (LQTS) is a cardiovascular disorder characterized by prolongation of the QT interval on the surface ECG and episodes of syncope and/or life-threatening cardiac arrhythmias, specifically of polymorphic ventricular tachycardia (VT) (torsade de pointes [TdP]). The molecular basis of LQTS is the prolongation of action potential duration resulting from defects in several ion channel genes. Mutations in KCNQ1 (LQT1) and HERG (LQT2) cause

defects in the delayed rectifier potassium currents,<sup>[4,5]</sup> whereas mutations in SCN5A (LQT3) cause a persistent cardiac sodium current.<sup>[6]</sup> LQT1 and LQT2 account for  $\approx 90\%$  of all genotyped patients. LQT3 is about 10–15% of all LQTS.<sup>[7]</sup> LQT3 has different features from LQT1 and LQT2. One of the most important clinical features is the basic therapy for LQTS,  $\beta$ -blocker, is less effective for LQT3, but mexiletine and flecainide might be beneficial.<sup>[8]</sup>

Determination of Brugada syndrome or LQT3-associated mutations can improve presymptomatic diagnosis, enable better follow-up of asymptomatic patients and facilitate choosing effective therapies earlier. In this study, we performed a genetic analysis in the translated region of SCN5A in the following Chinese patients: 4 patients diagnosed as Brugada syndrome, 9 patients suspected to have Brugada syndrome, and 3 LQTS patients suspected to be LQT3 without mutations in KCNQ1 and HERG. We identified 2 novel and a reported SCN5A mutations in patients with Brugada syndrome and a novel SCN5A mutation in a patient with LQT3.

## SUBJECTS AND METHODS

### Subjects

Four unrelated sporadic patients diagnosed as having Brugada syndrome, 9 unrelated sporadic patients suspected to have Brugada syndrome, and 3 unrelated patients suspected to be LQT3 without mutations in KCNQ1 and HERG confirmed by a previous research.<sup>[9]</sup> The patients and control subjects who participated in this study were all Chinese, all of whom provided informed consent, and were recruited from the Department of Cardiology, Peking University People's Hospital, China. Clinical diagnosis of Brugada syndrome was based on a consensus report in 2005,<sup>[3]</sup> namely, a typical ECG pattern characterized by a coved ST-segment elevation  $\geq 2$  mm in more than 1 right precordial lead ( $V_1$  to  $V_3$ ) at baseline in association with 1 or more clinical findings that include syncope, documented VF/polymorphic VT, or a family history of sudden cardiac death at age less than 45 years, and no other explanation for the ECG abnormality. The patients suspected to have Brugada syndrome were those having syncope, normal echocardiograms, and a coved ST-segment elevation  $< 1$  mm (1 patient) or a saddleback ST-segment elevation (7 patient) or a normal ECG (1 patient). LQT3 was suspected on the basis of QTc (the QT interval corrected for heart rate)  $\geq 460$  ms and late onset of abnormal T wave, the presence of syncope or TdP, and excluding acquired LQTS.<sup>[10]</sup> Clinical and laboratory investigations included a review of medical history, a complete physical examination, 12-lead ECG, 24-h ambulatory electrocardiographic

monitoring (Holter), transthoracic echocardiography, and blood biochemical test.

The control samples consisted of 50 unrelated healthy Chinese. None had Brugada-type or QT interval prolongation ECG findings, or a history of VT/VF or syncope. The protocol was approved by the Health Sciences Research Ethics Board of the Peking University.

### Mutation analysis

Genomic DNA was prepared from the peripheral blood lymphocytes by standard methods. All 28 exons of the SCN5A gene were amplified by polymerase chain reaction (PCR) using primers designed by Wang *et al.*<sup>[11]</sup> The PCR products were amplified and sequenced on both strands by the dideoxynucleotide chain termination method with fluorescent dideoxynucleotides, using an ABI 377 automated sequencer. The obtained sequence data were compared with previously reported SCN5A cDNA sequence (GenBank Accession number GI: 37622906). The probands were analyzed for mutations first. If a proband was found to have a mutation, the patient's family members and control subjects would be investigated for the mutation in the exon where mutation occurs.

## RESULTS

### Patients diagnosed with Brugada syndrome

Four patients diagnosed with Brugada syndrome were all men presenting syncope. Each patient had a coved-type ST-segment elevation  $\geq 2$  mm in leads  $V_1$  to  $V_2$  on the 12-lead ECG. RBBB was noted in 3 patients (patient 1, 2, and 4). A family history of sudden cardiac death at  $< 45$  years of age was noted in 1 patient (patient 2). All patients were recommended ICD, but none could afford the therapy. During follow-up, patient 2 was lost; patients 1, 3, and 4 were followed-up for 60, 7, and 24 months, respectively. No syncope occurred in 3 patients except that patient 4 had presyncope occasionally. Patient 1, 38 years old, had first syncope at the age of 33 years at rest in the night. He had a typical ECG of Brugada syndrome [Figure 1] and no abnormal physical condition and other significant laboratory abnormalities.

The 4 patients with clinical evidence of Brugada syndrome were sequenced for mutations in SCN5A. Two novel mutations were identified in patient 1. One heterozygous missense mutation was a G $\rightarrow$ A transition at nucleotide position 283 in exon 3 of SCN5A [Figure 2, upper panel] that led to the replacement of Valine by Isoleucine at codon 95 (V95I) in the N-terminus of the human cardiac sodium

channel  $\alpha$  subunit [Figure 3]. The other heterozygous missense mutation was a C→T transition at nucleotide position 4946 in exon 28 of SCN5A [Figure 2b], which was predicted to result in substitution of Alanine with Valine at codon 1649 (A1649V) in the S4/S5 linker in domain IV of SCN5A [Figure 3]. The parents of patient 1 were investigated [Figure 4a] and the other relatives of patient 1 refused to undergo mutation analyses. The father (II-1) was a heterozygous carrier of V95I and A1649V mutations. But he was asymptomatic with normal ECG. The mother (II-2) did not have the mutation.

### Patients suspected to have Brugada syndrome

Nine patients suspected to have Brugada syndrome were all men who refused to take drug challenge with sodium channel blockers. A family history of sudden cardiac death at <45 years of age was noted in only 1 patient (patient 4). None had physical and other significant laboratory abnormalities. Patient 9, 16 years old, was a student who had first syncope at rest in the last year. No syncope occurred thereafter but he often had palpitations at rest. He had normal ECG and didn't receive any treatment.

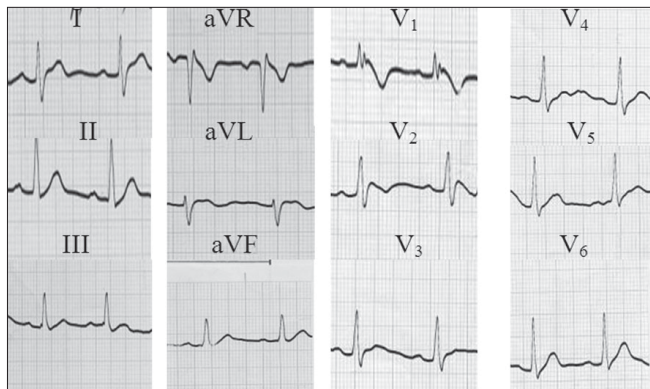

**Figure 1:** Twelve-lead electrocardiogram record of patient 1 with Brugada syndrome showing the ST-segment elevation in leads V1 to V2 and the incomplete right bundle-branch block pattern

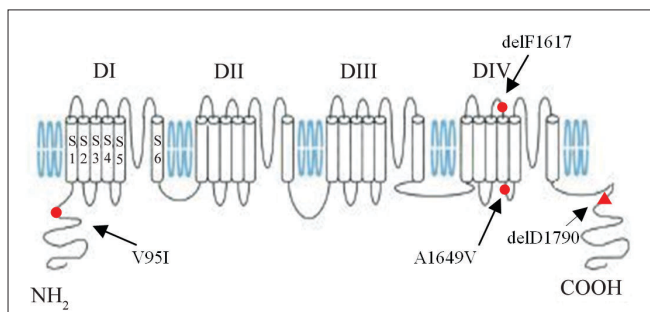
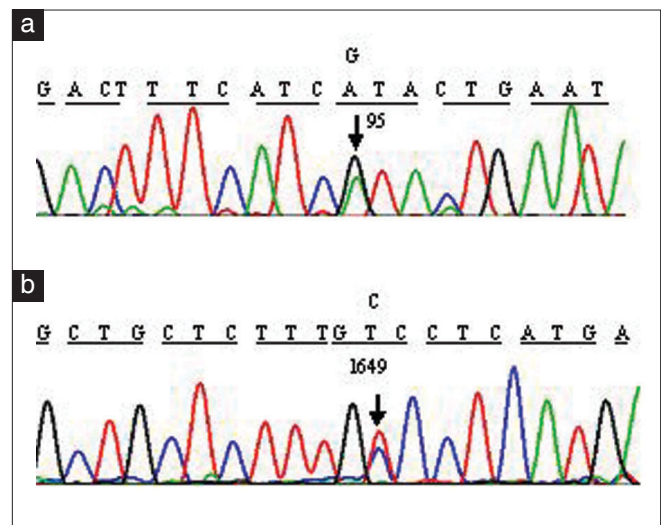

**Figure 3:** Predicted topology of the cardiac Na<sup>+</sup> channel is illustrated with locations of mutations associated with either BrS or LQT3 found in the present study

One mutation was found in patient 9. The heterozygous deletion mutation was 3 nucleotides (TCT) deletion at nucleotide position 4850–4852 in exon 28 of SCN5A [Figure 5] that caused Phenylalanine deletion at codon 1617 (delF1617) in the S3/S4 linker in domain IV of the human cardiac sodium channel [Figure 3]. The parents of patient 9 were investigated [Figure 4b] and the other relatives refused mutation analyses. The father (II-1) was a heterozygous carrier of the delF1617 mutation. But he was asymptomatic with normal ECG. The mother (II-2) did not have the mutation.

### Patients diagnosed with LQT3

Three patients diagnosed with LQT3 were all female with syncope or presyncope occurring at rest. All patients had QTc prolongation (519, 639, and 562 ms, respectively) and



**Figure 2:** Direct sequence analyses of PCR-amplified DNAs of SCN5A in patient 1 with Brugada syndrome. (a) There was a G to A substitution of codon 95 (Upper), (b) and a C to T substitution of codon 1649 (Lower), respectively.

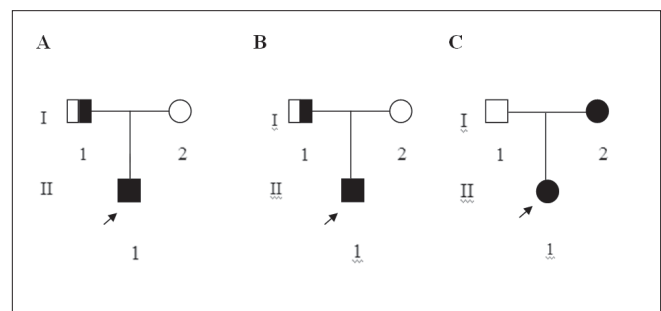

**Figure 4:** Detection of mutation in the family members. (a) Partial family members of patient 1 with Brugada syndrome. (b) Partial family members of patient 9 suspected to have Brugada syndrome. (c) Partial family members of patient 3 with LQT3. (Circles) Females; (Squares) males; empty symbols depict unaffected members; filled symbols depict mutation carriers with symptoms; half-filled symbols depict mutation carriers without symptoms; the proband is indicated by an arrow

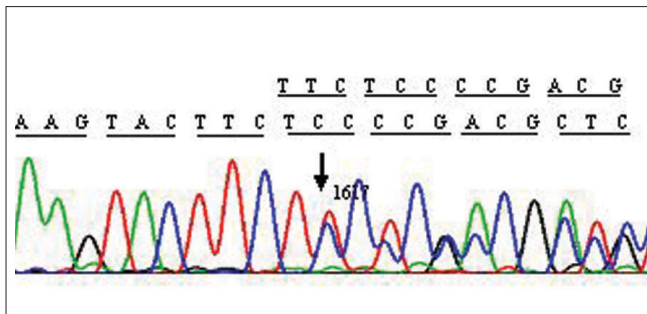

**Figure 5:** Sequence analyses of patient 9 suspected to have Brugada syndrome showed a three nucleotides (TCT) deletion at position 4850-5852 at codon 1617

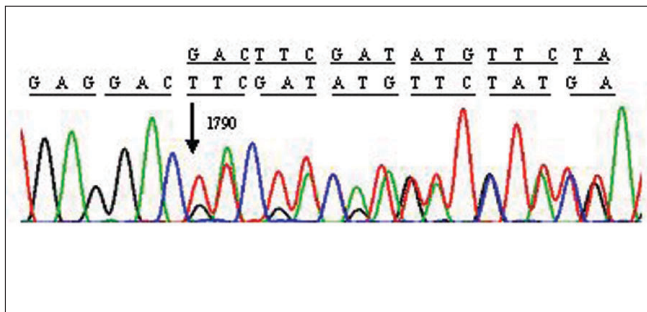
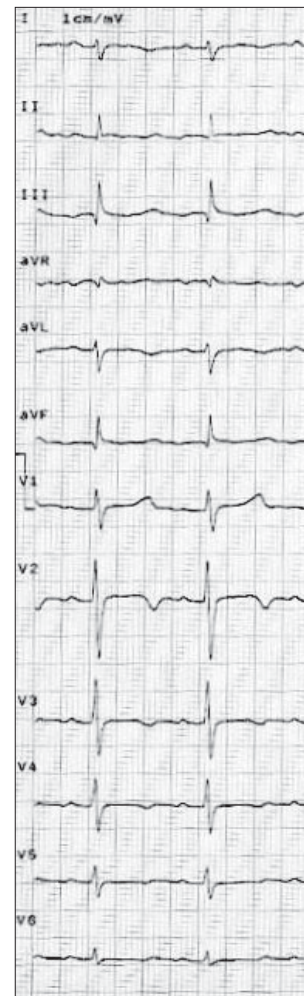

**Figure 7:** Sequence analyses of PCR products of exon 28 in SCN5A in patient 3 with LQT3. A three nucleotides (GAC) deletion at position 5368-5370 at codon 1790 was identified

late-onset abnormal T wave on the 12-lead ECG. None had physical and other significant laboratory abnormalities. Patient 1 was implanted a pacemaker because of complete atrioventricular block (III°AVB) and syncope did not occur in the following one and a half years. Patient 2 accepted left cardiac sympathetic denervation and syncope did not occur in the following 3 years. Patient 3, 27 years old, had recurrent presyncope for 4 years. Taking  $\beta$ -adrenergic blockers within therapeutic doses, she became sleepy and discontinued the medicine. She refused any other treatment including mexiletine. Her ECG was shown in Figure 6.

A novel mutation was found in patient 3. The heterozygous mutation was 3 nucleotides (GAC) deletion at nucleotide position 5368–5370 in exon 28 of SCN5A [Figure 7] that caused Aspartic acid deletion at codon 1790 (delD1790) in the C-terminus of the human cardiac sodium channel [Figure 3]. The parents of patient 3 were investigated [Figure 4c] and the other relatives refused mutation analyses. Her mother (II-2) was a heterozygous carrier of the delD1790 mutation. She also had a typical LQT3 ECG and syncope episodes. Her father (II-1) did not have the mutation.

Analysis of 100 control chromosomes did not identify the 4 mutations (V95I, A1649V, delF1617, and delD1790).



**Figure 6:** The twelve-lead ECG of patient 3 with LQT3 showed that QTc 562ms and delayed T-wave onset with biphasic T-wave morphology

## DISCUSSION

In the present study, the genetic nucleotide sequence of SCN5A was analyzed in both the Chinese patients with Brugada syndrome and Chinese patients with LQT3 and control subjects. We identified 2 novel single missense mutations, V95I and A1649V, which to our knowledge have not been previously reported in unrelated Chinese Brugada patients, and a reported deletion mutation, delF1617, in a patient suspected to have Brugada syndrome, and a novel deletion mutation, delD1790, which to our knowledge has not been previously reported in Chinese LQT3 patients.

SCN5A mutations can cause Brugada syndrome and LQT3. The reason that SCN5A mutations cause different phenotypes might be the complex relationships between structure and function of the SCN5A protein. Different mutations cause different diseases and also different gating or conductance changes of the sodium channel. SCN5A

mutations associated with Brugada syndrome render loss of function of the sodium channel because of the changes in the gating function of the sodium channel, including accelerated inactivation, slow reactivation, and entry of the sodium channel into an intermediate state of inactivation<sup>[12-14]</sup>; a decrease in the number of the sodium channel in the membrane resulting from failure of the sodium channel to express or intracellular trafficking defects;<sup>[15]</sup> destroyed conductance function of the sodium channel owing to mutations in the pore region of the channel.<sup>[16]</sup> The reduction in Na<sup>+</sup> current, especially in the epicardial cells will generate a potential gradient that can manifest as ST-segment elevation on the ECG. Different from Brugada syndrome, LQT3 is associated with SCN5A mutations that result in slowing or an increase in the reversibility of inactivation and an increase in the late component of sodium current.<sup>[17-20]</sup> The increase in late current prolongs the action potential duration and the QT interval on the ECG.

The SCN5A channel is a transmembrane protein composed of 4 homologous domains (DI–DIV), each containing 6 transmembrane segments (S1–S6). In the present study, V95I and A1649V mutations were found in a patient diagnosed with Brugada syndrome. V95I was in the N-terminus of the SCN5A channel. Priori *et al.* and Levy-Nissemna *et al.* reported that R27H, G35S, and R104Q mutations with Brugada syndrome were in the N-terminus of the SCN5A channel.<sup>[21,22]</sup> But there were no electrophysiologic data about these mutations. A1649V was found in the S4/S5 linker in domain IV of SCN5A. To our knowledge, no mutations linked to Brugada syndrome in the S4/S5 linker in domain IV were reported previously. The role of N-terminus and S4/S5 linker in domain IV in gating and conductance function of the Na<sup>+</sup> channel was not clear. We searched the SCN5A homology in several different isoforms (SCN4A, SCN1A, SCN3A, SCN8A, SCN9A) for sequence changes in the V95 and A1649, but no sequence variant was found at codon 95 and 1649, suggesting that the 2 positions are conserved. A1649 was the second amino acid residue next to DIVS4, which has been proved to be a voltage sensor responding to the changes in membrane potential and plays an important role in activation, fast inactivation, and slow inactivation of the sodium channel. Therefore, V95 and A1649 might have effects on maintaining the normal function of the sodium channel and A1649 might be associated with gating function of the sodium channel. In our study, the proband with V95I and A1649V had syncope and a typical Brugada syndrome ECG and the 2 amino acid changes were not found in 100 control chromosomes. Thus, the V95I and A1649V changes are likely to be mutations and not polymorphisms. The pattern in which the 2 mutations occurred in the family conformed to the autosomal dominant inheritance mode. The

reason that the proband's father had the same mutations as the proband but had normal ECG and no symptoms might be incomplete penetrance of Brugada syndrome and influences of environmental factors, such as temperature and genetic factors, such as regulatory genes.

DelF1617 mutation found in a patient suspected to have Brugada syndrome in our study was in the extracellular linker between segments S3 and S4 in domain IV of SCN5A. The mutation was originally reported and tentatively associated with LQT3 by Splawski *et al.* in 2000<sup>[23]</sup> In 2005, Chen *et al.*<sup>[24]</sup> assessed the biophysical properties of the mutant channel. Compared with the wild type, the inactivation of delF1617 was faster and the mean channel open times were shorter at negative potentials, whereas it tended to be the opposite at positive potentials. The authors concluded that this mutation can cause either a gain or loss of sodium current depending on the membrane potential. The results of *in vitro* expression displayed a potential for this mutation to induce an overlapping BrS-LQT3 phenotype. But no clinical data are currently available to support this hypothesis. In the present study, the proband and his father who carried delF1617 mutation had normal ECG. They refused to take drug challenge with sodium channel blockers. As the ECG patterns of Brugada syndrome can be dynamic and often concealed, and the biophysical properties of delF1617 mutant channel, the proband is most likely to be diagnosed with Brugada syndrome.

Numerous mutation analyses of LQT3 have shown that C-terminus appears to be a “hot-spot” for LQT3 mutations. Homology modeling of the SCN5A C-terminus predicts that the first half of the C-terminus domain consists of 6 helices (H1–H6), which are highly conserved among different human sodium channel isoforms, particularly the acid rich domain, containing H1 and H2.<sup>[25]</sup> Functional studies revealed that the proximal half of the C-terminus containing all of the helical structure markedly modulates channel inactivation but not activation. Studies of inherited mutations in the first 5 helices of the proximal region of the C-terminus, such as E1784K, D1795insD, Y1795C, and D1790G have indicated that all these mutations cause changes in channel inactivation with no reported effects on channel activation.<sup>[26-29]</sup> Moreover, E1784K mutation imposes allosteric rather than a direct effect on channel gating, whereas D1790G mutation induces changes in the interaction between the Na<sup>+</sup> channel  $\alpha$ - and  $\beta_1$ -subunits. H1 is composed of 14 amino acid residues, among which only 3 are hydrophobic and the others are all hydrophilic. Asp1790, the third amino acid residue in H1, is hydrophilic and conserved among different human sodium channel isoforms (SCN5A, SCN2A, SCN8A, SCN9A, SCN4A). Deletion of Asp1790 will alter the primary

structure of SCN5A protein that is closely associated with the overall structure and function of the protein. Therefore, we speculate that DelD1790 might influence the stability of H1  $\alpha$ -helical structure by changing the primary structure of the protein which in turn interrupts inactivation of Na<sup>+</sup> channel. However, the fact that DelD1790 mutation influences the interaction between the Na<sup>+</sup> channel  $\alpha$ - and  $\beta_1$ -subunits cannot be overlooked.

The failure to identify mutations in some individuals in our study may result from genetic heterogeneity, presence of mutations in regulatory sequences, or phenotypic errors. In a future study, we shall conduct functional analyses of the mutations using a mammalian expression system, which may help clarify the pathogenic involvement of these mutations. We shall also attempt to identify additional genes that may be responsible for the Brugada syndrome or LQT3.

## REFERENCES

- Brugada P, Brugada J. Right bundle branch block, persistent ST-segment elevation and sudden cardiac death: a distinct clinical and electrocardiographic syndrome: a multicenter report. *J Am Coll Cardiol* 1992;20:1391-6.
- Antzelevitch C, Brugada P, Brugada J, Brugada R, Shimizu W, Gussak I, *et al.* Brugada syndrome: a decade of progress. *Circ Res* 2002;91:1114-8.
- Antzelevitch C, Brugada P, Borggrefe M, Brugada J, Brugada R, Corrado D, *et al.* Brugada Syndrome: Report of the Second Consensus Conference: endorsed by the Heart Rhythm Society and the European Heart Rhythm Association. *Circulation* 2005;111:659-70.
- Wang Q, Curran ME, Splawski I, Burn TC, Millholland JM, VanRaay TJ, *et al.* Positional cloning of a novel potassium channel gene: KVLQT1 mutations cause cardiac arrhythmias. *Nat Genet* 1996;12:17-23.
- Curran ME, Splawski I, Timothy KW, Vincent GM, Green ED, Keating MT. A molecular basis for cardiac arrhythmia: HERG mutations cause long QT syndrome. *Cell* 1995;80:795-803.
- Wang Q, Shen J, Splawski I, Atkinson D, Li Z, Robinson JL, *et al.* SCN5A mutations associated with an inherited cardiac arrhythmia, long QT syndrome. *Cell* 1995;80:805-11.
- Phillips JR, Case CL. Evaluation and treatment of pediatric patients with congenital or acquired long QT syndromes. *Prog Pediatr Cardiol* 2001;13:101-10.
- Moss AJ, Zareba W, Hall WJ, Schwartz PJ, Crampton RS, Benhorin J, *et al.* Effectiveness and limitations of beta-blocker therapy in congenital long-QT syndrome. *Circulation* 2000;101:616-23.
- Liu W, Hu D, Li C, Li P, Li Y, Li Z, *et al.* Mutation analysis of potassium channel genes KCNQ1 and KCNH2 in patients with long QT syndrome. *Chin Med J (Engl)* 2003;116:1333-5.
- Zhang L, Timothy KW, Vincent GM, Lehmann MH, Fox J, Giulii LC, *et al.* Spectrum of ST-T-Wave Patterns and Repolarization Parameters in Congenital Long-QT Syndrome: ECG findings identify genotypes. *Circulation* 2000;102:2849-55.
- Wang Q, Li Z, Shen J, Keating MT. Genomic organization of the human SCN5A gene encoding the cardiac sodium channel. *Genomics* 1996;34:9-16.
- Deschênes I, Baroudi G, Berthet M, Barde I, Chalvidan T, Denjoy I, *et al.* Electrophysiological characterization of SCN5A mutations causing long QT (E1784K) and Brugada (R1512W and R1432G) syndromes. *Cardiovasc Res* 2000;46:55-65.
- Rook MB, Bezzina Alshinawi C, Groenewegen WA, van Gelder IC, van Ginneken AC, Jongasma HJ, *et al.* Human SCN5A gene mutations alter cardiac sodium channel kinetics and are associated with the Brugada syndrome. *Cardiovasc Res* 1999;44:507-17.
- Akai J, Makita N, Sakurada H, Shirai N, Ueda K, Kitabatake A, *et al.* A novel SCN5A mutation associated with idiopathic ventricular fibrillation without typical ECG findings of Brugada syndrome. *FEBS Lett* 2000;479:29-34.
- Baroudi G, Pouliot V, Denjoy I, Guicheney P, Shrier A, Chahine M. Novel mechanism for Brugada syndrome: defective surface localization of an SCN5A mutant (R1432G). *Circ Res* 2001;88:E78-83.
- Kyndt F, Probst V, Potet F, Demolombe S, Chevallier JC, Baro I, *et al.* Novel SCN5A mutation leading either to isolated cardiac conduction defect or Brugada syndrome in a large French family. *Circulation* 2001;104:3081-6.
- Abriel H, Cabo C, Wehrens XH, Rivolta I, Motoike HK, Memmi M, *et al.* Novel arrhythmogenic mechanism revealed by a long-QT syndrome mutation in the cardiac Na<sup>+</sup> channel. *Circ Res* 2001;88:740-5.
- Rivolta I, Clancy CE, Tateyama M, Liu H, Priori SG, Kass RS. A novel SCN5A mutation associated with long QT-3: altered inactivation kinetics and channel dysfunction. *Physiol Genomics* 2002;10:191-7.
- Groenewegen WA, Bezzina CR, van Tintelen JP, Hoorntje TM, Mannens MM, Wilde AA, *et al.* A novel LQT3 mutation implicates the human cardiac sodium channel domain IVS6 in inactivation kinetics. *Cardiovasc Res* 2003;57:1072-8.
- Clancy CE, Tateyama M, Liu H, Wehrens XH, Kass RS. Non-equilibrium gating in cardiac Na<sup>+</sup> channels: an original mechanism of arrhythmia. *Circulation* 2003;107:2233-7.
- Priori SG, Napolitano C, Gasparini M, Pappone C, Della Bella P, Giordano U, *et al.* Natural history of Brugada syndrome: insights for risk stratification and management. *Circulation* 2002;105:1342-7.
- Levy-Nissenbaum E, Eldar M, Wang Q, Lahat H, Belhassen B, Ries L, *et al.* Genetic analysis of Brugada syndrome in Israel: two novel mutations and possible genetic heterogeneity. *Genet Test* 2001;5:331-4.
- Splawski I, Shen J, Timothy KW, Lehmann MH, Priori S, Robinson JL, *et al.* Spectrum of mutations in long-QT syndrome genes. KVLQT1, HERG, SCN5A, KCNE1, KCNE2. *Circulation* 2000;102:1178-85.
- Chen T, Inoue M, Sheets MF. Reduced voltage dependence of inactivation in the SCN5A sodium channel mutation delF1617. *Am J Physiol Heart Circ Physiol* 2005;288:H2666-76.
- Cormier JW, Rivolta I, Tateyama M, Yang AS, Kass RS. Secondary structure of the human cardiac Na<sup>+</sup> channel C terminus. *J Biol Chem* 2002;277:9233-41.
- Wei J, Wang DW, Alings M, Fish F, Wathen M, Roden DM, *et al.* Congenital long-QT syndrome caused by a novel mutation in a conserved acidic domain of the cardiac Na<sup>+</sup> channel. *Circulation* 1999;99:3165-71.
- Bezzina C, Veldkamp MW, van Den Berg MP, Postma AV, Rook MB, Viersma JW, *et al.* A signal Na(+) channel mutation causing both long-QT and Brugada syndromes. *Circ Res* 1999;85:1206-13.
- Rivolta I, Abriel H, Tateyama M, Liu H, Memmi M, Vardas P, *et al.* Inherited Brugada and long QT-3 syndrome mutations of a single channel residue of the cardiac sodium channel confer distinct channel and clinical phenotypes. *J Biol Chem* 2001;276:30623-30.
- An RH, Wang XL, Kerem B, Benhorin J, Medina A, Goldmit M, *et al.* Novel LQT-3 mutation affects Na<sup>+</sup> channel activity through interactions between  $\alpha$ - and  $\beta$ -subunits. *Circ Res* 1998;83:141-6.

Source of Support: Nil, Conflict of Interest: None declared.