

Bending Resistance and Cyclic Fatigue Life of a new Single-File Reciprocating Instrument Waveone Gold

Emmanuel João Nogueira Leal SILVA, Justine Monnerat TINOCO, Eduardo Muniz Barretto TINOCO, Victor Talarico Leal VIEIRA, Luciana Moura SASSONE, Hélio Pereira LOPES

ABSTRACT

Objective: The present study aimed to evaluate the bending resistance and cyclic fatigue fracture resistance of a new single-file reciprocating instrument called WaveOne Gold. Reciproc and WaveOne instruments were used as references for comparison.

Methods: Sixty 25-mm NiTi instruments (Reciproc R25, WaveOne Primary and WaveOne Gold Primary) were tested. Flexibility was determined by applying 45° bending tests using a universal testing machine (n=10). A custom-made device was used during cyclic fatigue test (n=10), comprising a stainless steel artificial canal measuring 1.4 mm in diameter, 19 mm in total length with an 86° angle and 6 mm radius of curvature. Possible deformations at the helical shaft and mode of fracture were evaluated using scanning electron microscopy analysis. Statistical analysis was performed using one-way analysis of variance. Post hoc pair-wise comparisons were performed using Tukey's test for multiple comparisons (P<0.05).

Results: WaveOne presented significantly higher bending resistance than the other tested systems (P<0.05), whereas Reciproc presented the lowest bending resistance (P<0.05). Reciproc revealed a significantly longer cyclic fatigue fracture resistance than the other systems (P<0.05).

Conclusion: Although WaveOne Gold presented higher flexibility than WaveOne, no differences in the resistance to fatigue were observed between both systems. The Reciproc files were more flexible and resistant to fatigue for the angle of curvature of 86° and 6 mm radius than WaveOne and WaveOne Gold files.

Keywords: Bending resistance, cyclic fatigue, NiTi alloy, reciprocating movement, WaveOne Gold

Please cite this article as: Silva EJNL, Tinoco JM, Tinoco EMB, Vieira VTL, Sassone LM, Lopes HP. Bending Resistance and Cyclic Fatigue Life of a new Single-File Reciprocating Instrument Waveone Gold. *Eur Endod J* (2016) 1:4.

From the Department of Endodontics (E.J.N.L.S. [✉](mailto:nogueiraemmanuel@hotmail.com) nogueiraemmanuel@hotmail.com, V.T.V.) Grande Rio University (UNIGRANRIO) School of Dentistry, Rio de Janeiro, Brazil; Department of Endodontics (E.J.N.L.S., J.M.T., E.M.T., L.M.S.), Rio de Janeiro State University (UERJ) School of Dentistry, Rio de Janeiro, Brazil; Department of Endodontics (H.P.L) Estácio de Sá University (UNESA) School of Dentistry, Rio de Janeiro, Brazil.

Received 9 June 2016, revision requested 23 June 2016, revision received 1 August 2016, accepted 30 August 2016.

Published online: 11 October 2016
DOI: 10.5152/eej.2016.16018

This work is licensed under a Creative Commons Attribution-NonCommercial 4.0 International License.



INTRODUCTION

Despite the numerous advantages of nickel–titanium (NiTi) rotary instruments, these instruments present a risk of fracture when used in curved canals, which could compromise the prognosis of root canal treatment (1). Different alloys and variations in cross-sectional designs have been suggested to increase the resistance to fatigue fracture and flexibility of these instruments (2, 3). Additionally, reciprocating motion kinematics has also been demonstrated to extend the lifespan of a NiTi instrument and its resistance to cyclic fatigue in comparison with continuous rotation movement (2, 4, 5). In this kinematics, the instruments travel a shorter angular distance compared to in conventional rotary kinematics, which are subject to lower stress values, thus rendering an extended fatigue fracture resistance (4, 5). WaveOne (Dentsply Maillefer, Ballaigues, Switzerland) and Reciproc (VDW, Munich, Germany) are the main commercially available single-file systems for root canal preparation using reciprocating motion.

The thermal treatment of NiTi alloys has been successfully used to improve the mechanical properties of endodontic instruments (6–8). Thermomechanical processing is frequently used to optimise the microstructure and transformation behaviour of NiTi alloys, which in turn has a significant influence on the mechanical properties of NiTi files (6–8). Recently, a new reciprocating system was launched in the endodontic market, namely WaveOne Gold (Dentsply Maillefer). According to the manufacturer, WaveOne Gold offers the simplicity of the WaveOne system, but with additional advantages, specifically it is fabricated with NiTi and underwent repeated heat-treatment and cooling to improve the file's flexibility and strength, allowing a broader range of canal morphologies to be shaped more safely and efficiently. Moreover, the cross-section in WaveOne Gold has been improved from the triangular shape of its precursor to a parallelogram design that gives one or two cutting edges depending on the location along the file. According to the manufacturer, this

new design minimizes the screwing effect and reduces the torque. However, up to now, no study has yet been done to evaluate the cyclic fatigue fracture resistance and the bending resistance of WaveOne Gold. Therefore, the aim of the present study was to evaluate and compare the cyclic fatigue fracture resistance and bending resistance of Reciproc R25, WaveOne Primary and WaveOne Gold Primary instruments. The null hypotheses tested were as follows:

That there are no differences in the cyclic fatigue fracture resistance among the instruments;

That there are no differences in the bending resistance among the instruments.

MATERIALS AND METHODS

A sample size of 60 NiTi instruments for use under reciprocation movement [Reciproc (25/0.08), WaveOne (25/0.08) and WaveOne Gold (25/0.07)] was tested. For reliability and standardisation of the study, all the NiTi instruments were examined for defects and deformities under a stereomicroscope.

Bending resistance test

The bending resistance test was performed for 10 randomly selected instruments of each system using a universal testing machine (DL 200MF; Emic, São José dos Pinhais, Brazil). A 20N load was applied at 15 mm/min by means of a flexible stainless steel wire with one end fastened to the testing machine head and the other end attached 3 mm from the instrument tip, as previously described (9, 10). This test was conducted until the tip of each specimen underwent an elastic displacement of 45°. The force values were acquired in the 45° position. (Figure 1).

Cyclic fatigue test

This test was conducted using a customised device. From a stainless steel tube, a canal with a diameter of 1.4 mm and a total length of 19 mm was fabricated. A 9 mm long curved segment with an 86° angle and 6 mm radius (measured at the internal concave surface of the tube) was created between two straight segments measuring 7 mm and 3 mm (9, 10) (Figure 1).

Ten instruments of each system were activated using a 6:1 reduction handpiece (Sirona Dental Systems, Bensheim, Germany) driven by a Silver Reciproc (VDW) endodontic motor using the programs 'RECIPROC ALL' and 'WAVEONE ALL' for Reciproc and WaveOne systems, respectively. The simulated canal was filled with glycerin to reduce the friction and heat production. Each instrument was introduced into the canal until the tip touched a shield positioned at the other extremity. Afterwards, the shield was removed, as it was only used to standardise the instrument penetration into the canal. The time was recorded and stopped in the instant that a fracture was detected audibly and/or visually. Video recording was performed concurrently, and the records were then observed to cross-check the time of file fracture and to avoid human error (11).

The fractured instrument was further cleansed in an ultrasonic bath in absolute alcohol for 5 min. A scanning electron microscope (SEM; JSM 5800; JEOL, Tokyo, Japan) was used to examine the helical shaft and the fracture surfaces of the fractured instruments to determine the fracture mode and the oc-

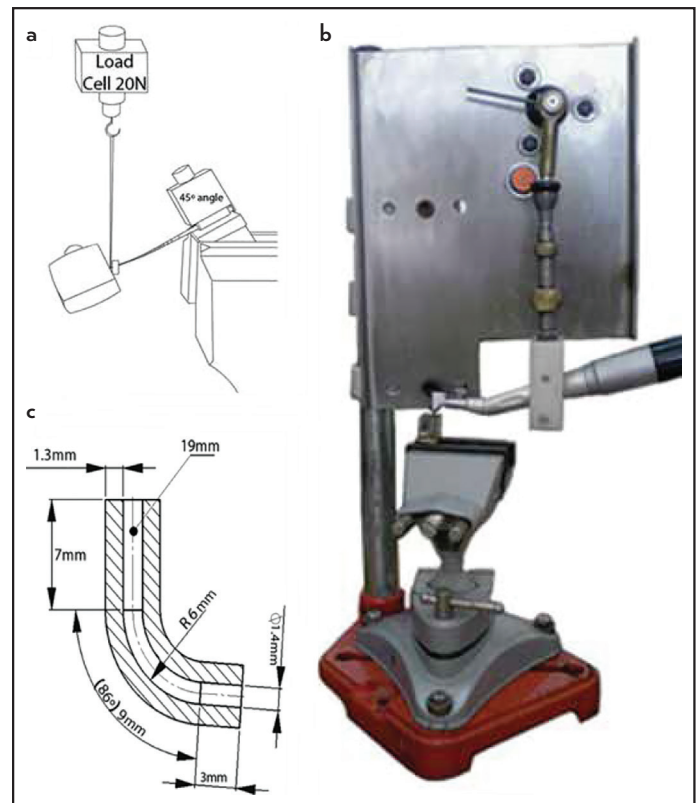

Figure 1. a-c. Set up of bending resistance test (a), apparatus developed for the cyclic fatigue test apparatus (b) and the canal geometry schematic drawing (c)

currence of plastic deformation in the helical shaft. Different magnifications were used (100X and 300X) and the photomicrographs were used for further analyses.

Statistical analysis

A bell-shaped distribution (D'Agostino and Person omnibus normality test) was observed; therefore, statistical analysis was performed using One-way analysis of variance. Post hoc pair-wise comparisons were performed using Tukey's test for multiple comparisons ($P < 0.05$). SPSS 11.0 (SPSS Inc., Chicago, IL, USA) and Origin 6.0 (Microcal Software, Inc., Northampton, MA, USA) were used as the analytical tools.

RESULTS

The means and standard deviations of the bending resistance and cyclic fatigue tests are shown in Table 1. WaveOne presented significantly higher bending resistance than the other tested systems ($P < 0.05$), while Reciproc presented the lowest bending resistance ($P < 0.05$). Moreover, Reciproc revealed a significantly longer cyclic fatigue fracture resistance ($P < 0.05$).

TABLE 1. Mean and standard deviation of bending resistance values and time to failure of the instruments subjected to static test

Instruments	Maximum load (g)	Time to failure (sec)
Reciproc	274.9±19.02 ^A	212.8±35.5 ^A
WaveOne	544.8±19.9 ^C	93.9±17.6 ^B
WaveOne Gold	330.3±39.1 ^B	92.2±4.6 ^B

Different superscript letters represent statistical differences ($P < 0.05$)

No statistical differences were observed between WaveOne and WaveOne Gold ($P < 0.05$) regarding the cyclic fatigue fracture resistance.

SEM analysis revealed that all the tested instruments displayed morphologic characteristics of a ductile fracture. No plastic deformation occurred in the helical shaft of the instruments (Figure 2).

DISCUSSION

The dynamic cyclic fatigue model has been previously suggested in order to evaluate the cyclic fatigue fracture resistance of NiTi files (5, 10). Indeed, this model approximates to a clinical condition of brushing or pecking motion (12); however, some limitations are observed when using this model. First, the instruments to be tested are not constrained in a precise path. Moreover, the amplitude and speed of the axial movements could be standardised using the dynamic model; nonetheless, these variables are subjective and not constant and reproducible in clinical circumstances, because this up-and-down motion is manually controlled and operator dependent (13). Therefore, in order to eliminate confounding factors from other mechanisms of instrument separation apart from cyclic fatigue, the static model was selected in the present study.

The first null hypothesis was not accepted, as a significant difference in cyclic fatigue fracture resistance was observed among the instruments. Reciproc showed a higher cyclic fatigue fracture resistance when compared to WaveOne and WaveOne Gold instruments. Previous studies already showed the difference in cyclic fatigue fracture resistance of Reciproc

and WaveOne instruments (2, 10, 14). WaveOne Gold has a smaller apical taper than WaveOne and Reciproc instruments.

Moreover, it incorporates a new NiTi alloy which has undergone a thermomechanical treatment that increases its flexibility. This treatment is the same as that used in the ProTaper Gold instruments. Previous studies comparing ProTaper Universal with ProTaper Gold (with an identical geometric architecture and operation mode and only differences in the metallic alloy) demonstrated improved cyclic fatigue fracture resistance for the ProTaper Gold instruments (15-17). Therefore, better cyclic fatigue fracture resistance results of the WaveOne Gold instrument would be expected, especially when compared to the WaveOne instrument. However, it is important to point out that several other factors would also have considerable influence on the fatigue behaviour and stress distribution of NiTi files, including the cross-sectional area, number of threads, helical angle and others. WaveOne Gold has notable design differences when compared to the WaveOne instrument. Moreover, during the instrument fabrication, machining defects can be performed. The SEM evaluation showed different patterns in surface quality in the different systems (Figure 1 a, b, c): WaveOne and WaveOne Gold presented more defects when compared to Reciproc. The higher amount of these defects may negatively influence the lower cyclic fatigue fracture resistance of both WaveOne systems.

Another key result of this study indicated that WaveOne files required significantly greater loads than other tested systems to reach a 45° deflection ($P < 0.05$). Moreover, Reciproc required a lower load to reach a 45° deflection when compared to WaveOne Gold ($P < 0.05$). This indicates that Reciproc is more flexible

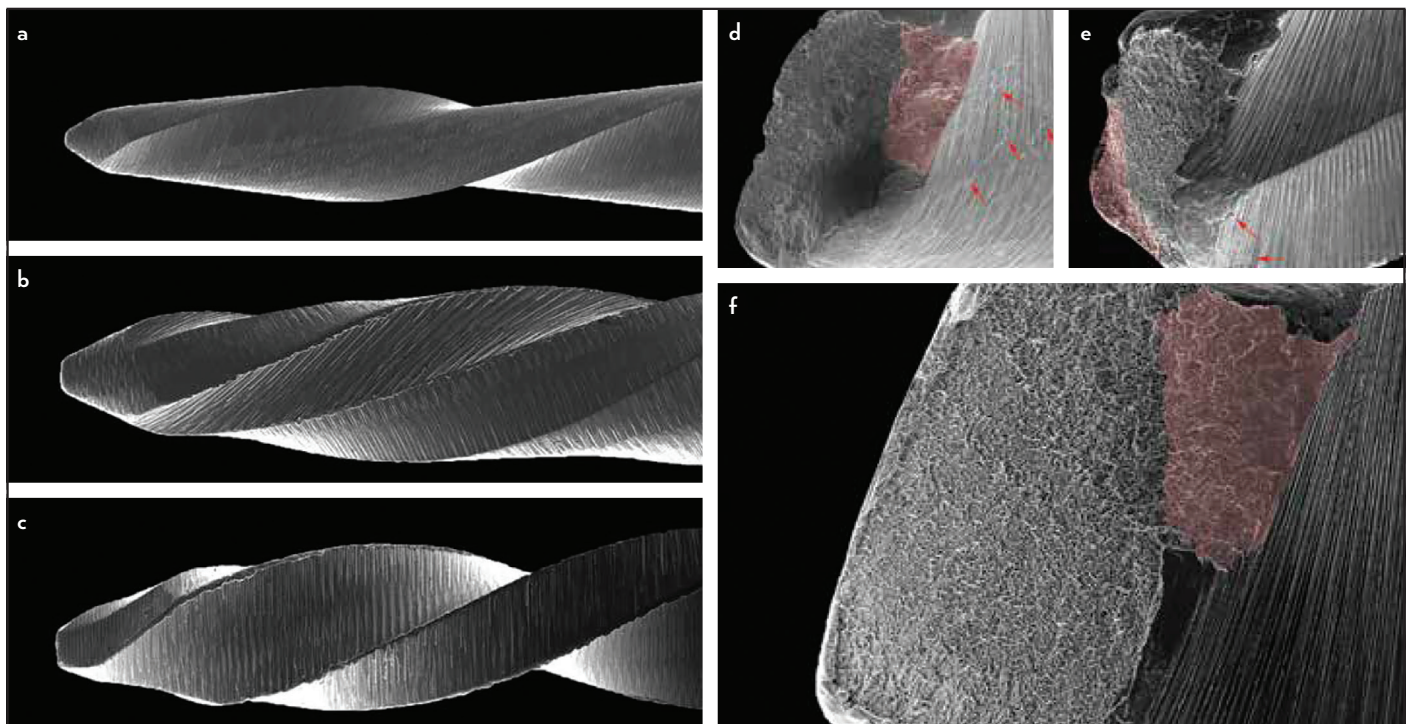

Figure 2. a-f. Surface finishing of (a) Reciproc, (b) WaveOne and (c) WaveOne Gold instruments showing different patterns (100X magnification). Fractured surfaces of (d) Reciproc, (e) WaveOne and (f) WaveOne Gold instruments showing morphologic characteristics of the ductile type in 300X magnification. Red areas are the crack initiation region, and the red arrows indicate the cracks present in the overload stress zone

than the other instruments; hence, the second null hypothesis was rejected. Several previous studies demonstrated that rigid instruments present a lower number of cycles to fracture as a consequence of the build-up of tensions at the point of maximum flexure (2, 4, 9, 10, 14). However, despite the greater flexibility of WaveOne Gold, no differences were observed between WaveOne and WaveOne Gold in terms of cyclic fatigue fracture resistance. According to the manufacturer, the new parallelogram cross-section gives one or two cutting edges depending on the location along the instrument; this can generate a higher state of stress when compared with the triangular shape, which distributes the load over more cutting edges. Therefore, the effect of the geometry of the new cross-section seems to have more impact than the flexibility provided by the new gold alloy when files are submitted to the cyclic fatigue test.

The SEM analysis showed typical ductile fractographic appearances of cyclic fatigue fractures with micro-voids (4, 9, 10). The instruments showed the presence of crack initiation areas and overload stress zones, with no morphologic differences among the three different systems (Figure 1 d, e and f).

Under the limitations of the present study, it can be concluded that Reciproc files are more flexible and resistant to fatigue than WaveOne and WaveOne Gold files. Moreover, although WaveOne Gold presented higher flexibility than WaveOne, no differences in the resistance to fatigue were observed between both systems.

Disclosures

Ethical Approval: The authors declare that this article does not contain any studies with human participants and does not require ethics committee approval.

Informed Consent: N/A

Peer-review: Externally peer-reviewed.

Authorship contributions: Concept - E.J.S., L.M.S., H.P.L.; Design - E.J.S., V.T.V.; Supervision - E.J.S., H.P.L.; Funding - N/A; Materials - N/A; Data Collection and/or Processing - J.M.T., E.T., E.J.S.; Analysis and/or Interpretation - E.J.S., V.T.V.; Literature Review - E.J.S.; Writer - E.J.S., L.M.S.; Critical Review - E.J.S.

Conflict of interest: No conflict of interest was declared by the authors.

Financial Disclosure: The authors declared that this study has received no financial support.

REFERENCES

- Ankrum MT, Hartwell GR, Truitt JE. K3 Endo, ProTaper, and ProFile systems: breakage and distortion in severely curved roots of molars. *J Endod* 2004; 30:234-7.
- Plotino G, Grande NM, Testarelli L, Gambarini G. Cyclic fatigue of Reciproc and WaveOne reciprocating instruments. *Int Endod J* 2012; 45:614-8.
- Gambarini G, Rubini AG, Al Sudani D, et al. Influence of different angles of reciprocation on the cyclic fatigue of nickel-titanium endodontic instruments. *J Endod* 2012; 38:1408-11.
- De-Deus G, Moreira EJ, Lopes HP, Elias CN. Extended cyclic fatigue life of F2 ProTaper instruments used in reciprocating movement. *Int Endod J* 2010; 43:1063-8.
- Kiefner P, Ban M, De-Deus G. Is the reciprocating movement per se able to improve the cyclic fatigue resistance of instruments? *Int Endod* 2014; 47:430-6.
- Bardsley S, Peters CI, Peters OA. The effect of three rotational speed settings on torque and apical force with vortex rotary instruments in vitro. *J Endod* 2011; 37:860-4.
- Gao Y, Gutmann JL, Wilkinson K, et al. Evaluation of the impact of raw materials on the fatigue and mechanical properties of ProFile Vortex rotary instruments. *J Endod* 2012; 38:398-401.
- Shen Y, Coil JM, Zhou HM, et al. ProFile Vortex instruments after clinical use: a metallurgical properties study. *J Endod* 2012; 38:1613-7.
- Lopes HP, Elias CN, Vieira VT, et al. Effects of electropolishing surface treatment on the cyclic fatigue resistance of BioRace nickel-titanium rotary instruments. *J Endod* 2010; 36:1653-7.
- De-Deus G, Vieira VT, Silva EJ, Lopes H, Elias CN, Moreira EJ. Bending resistance and dynamic and static cyclic fatigue life of Reciproc and WaveOne large instruments. *J Endod* 2014; 40:575-9.
- Pedullà E, Grande NM, Plotino G, Gambarini G, Rapisarda E. Influence of continuous or reciprocating motion on cyclic fatigue resistance of 4 different nickel-titanium rotary instruments. *J Endod* 2013; 39:258-61.
- Plotino G, Grande NM, Cordaro M, Testarelli L, Gambarini G. A review of cyclic fatigue testing of nickel-titanium rotary instruments. *J Endod* 2009; 35:1469-76.
- Wan J, Rasimick BJ, Musikant BL, Deutsch AS. A comparison of cyclic fatigue resistance in reciprocating and rotary nickel-titanium instruments. *Aust Endod J* 2011; 37:122-7.
- Arias A, Perez-Higuerras JJ, de la Macorra JC. Differences in cyclic fatigue resistance at apical and coronal levels of Reciproc and WaveOne new files. *J Endod* 2012; 38:1244-8.
- Hieawy A, Haapasalo M, Zhou H, Wang ZJ, Shen Y. Phase Transformation Behavior and Resistance to Bending and Cyclic Fatigue of ProTaper Gold and ProTaper Universal Instruments. *J Endod* 2015; 41:1134-8.
- Uygun AD, Kol E, Topçu MK, Seckin F, Ersoy I, Tanriver M. Variations in cyclic fatigue resistance among ProTaper Gold, ProTaper Next and ProTaper Universal instruments at different levels. *Int Endod J* 2016; 49:494-9.
- Elnaghy, A. M., Elsaka, S. E. Mechanical properties of ProTaper Gold nickel-titanium rotary instruments. *Int Endod J* [Epub ahead of print].