

Molecular basis of potassium channels in pancreatic duct epithelial cells

Mikio Hayashi^{†,*} and Ivana Novak^{*}

Department of Biology; University of Copenhagen; Copenhagen, Denmark;

[†]Current affiliation: Department of Physiology; Kansai Medical University; Hirakata, Japan**Keywords:** cancer, EAG2, epithelia, HERG, pancreas, SK4, Slack, Slick, Slo1, TASK-2

Abbreviations: AKAP, A-kinase anchoring protein; BK, voltage – and Ca²⁺-dependent maxi-K⁺; BxPC3, human pancreas adenocarcinoma cell line; Capan-1, human pancreas adenocarcinoma cell line; CFPAC-1, human cystic fibrosis pancreatic adenocarcinoma cell line; CFTR, cystic fibrosis transmembrane conductance regulator; DC-EBIO, 5,6-dichloro-1-ethyl-1,3-dihydro-2*H*-benzimidazole-2-one; DHS-I, dehydrosoyasaponin I; DIDS, 4,4'-diisothiocyanatostilbene-2,2'-disulfonic acid; E-4031, *N*-[4-[1-[2-(6-methylpyridin-2-yl)ethyl]piperidine-4-carbonyl]phenyl] methanesulfonamide; EAG, ether-à-go-go gene; 1-EBIO, 1-ethyl-2-benzimidazolinone; HERG, human ether-à-go-go related gene; HPAF, human pancreatic ductal adenocarcinoma cell line; ICA-105574, 3-nitro-*N*-(4-phenoxyphenyl) benzamide; IK, intermediate-conductance Ca²⁺-activated K⁺; *I*_{sc}, short-circuit current; K_{2p}, two-pore domain K⁺ channels; K_{ir}, inward rectifier potassium channel; L-364,373, (3-*R*)-1,3-dihydro-5-(2-fluorophenyl)-3-(1*H*-indol-3-ylmethyl)-1-methyl-2*H*-1,4-benzodiazepin-2-one; LY97241, *N*-ethyl-*N*-[4-(4-nitrophenyl)butyl]heptan-1-amine; NS11021, 1-(3,5-bis-trifluoromethyl-phenyl)-3-[4-bromo-2-(1*H*-tetrazol-5-yl)-phenyl]-thiourea; NS1608, *N*-(3-(trifluoromethyl)phenyl)-*N'*-(2-hydroxy-5-chlorophenyl)urea; PD-118057, [2-(4-[2-(3,4-dichloro-phenyl)-ethyl]-phenylamino)-benzoic acid; PKA, cAMP-dependent protein kinase; PKC, protein kinase C; PMA, phorbol 12-myristate 13-acetate; Ro-20-1724, 4-(3-butoxy-4-methoxybenzyl)-2-imidazolidinone; Slack, sequence like a calcium-activated K⁺ channel; Slick, sequence like an intermediate conductance K⁺ channel; TALK, TWIK-related alkaline pH-activated K⁺ channel; TASK, TWIK-related acid-sensitive K⁺ channel; TRAM-34, 1-[(2-chlorophenyl)diphenylmethyl]-1*H*-pyrazole; TWIK, tandem of P-domains in a weak inward rectifying K⁺ channel; *V*_{1/2}, half-maximal voltage; XE991, 10,10-bis(4-pyridinylmethyl)-9(10*H*)-anthracenone

Potassium channels regulate excitability, epithelial ion transport, proliferation, and apoptosis. In pancreatic ducts, K⁺ channels hyperpolarize the membrane potential and provide the driving force for anion secretion. This review focuses on the molecular candidates of functional K⁺ channels in pancreatic duct cells, including *KCNK4* (K_{Ca}3.1), *KCNMA1* (K_{Ca}1.1), *KCNQ1* (K_V7.1), *KCNH2* (K_V11.1), *KCNH5* (K_V10.2), *KCNT1* (K_{Ca}4.1), *KCNT2* (K_{Ca}4.2), and *KCNK5* (K_{2p}5.1). We will give an overview of K⁺ channels with respect to their electrophysiological and pharmacological characteristics and regulation, which we know from other cell types, preferably in epithelia, and, where known, their identification and functions in pancreatic ducts and in adenocarcinoma cells. We conclude by pointing out some outstanding questions and future directions in pancreatic K⁺ channel research with respect to the physiology of secretion and pancreatic pathologies, including pancreatitis, cystic fibrosis, and cancer, in which the dysregulation or altered expression of K⁺ channels may be of importance.

Introduction

Potassium channels (K⁺ channels) are very important membrane proteins present in every cell. They determine the cell membrane

potential and thereby regulate the excitability of neurons and myocytes and transport of ions and water in epithelia, such as the pancreas and salivary glands. Duct epithelial cells in the pancreas secrete a HCO₃⁻-rich pancreatic juice that neutralizes acid chyme in the duodenum. Secretin, acetylcholine, and ATP stimulate fluid secretion via signal transduction involving cAMP and Ca²⁺ signaling pathways. The generally accepted model for HCO₃⁻ transport involves Cl⁻-HCO₃⁻ exchangers (SLC26A3 and SLC26A6) that operate in parallel with cAMP-activated Cl⁻ channels (CFTR) or Ca²⁺-activated Cl⁻ channels (most likely TMEM16A) on the luminal membrane and Na⁺-coupled transporters such Na⁺-K⁺-Cl⁻ co-transporter (NKCC1), Na⁺-HCO₃⁻ co-transporter (SLC4A4), and Na⁺-H⁺ exchanger (SLC9A1) and Na⁺-K⁺-pump on the basolateral membrane (Fig. 1).¹⁻³ In addition, H⁺-K⁺-pumps are expressed on the luminal and basolateral membranes of pancreatic ducts.⁴ K⁺ channels are clearly important for setting the resting membrane potential and providing the driving force for anion exit and fluid secretion in a stimulated epithelium.^{1-3,5} K⁺ channels may also provide the transport partners for H⁺-K⁺-pumps.⁴ In addition, certain K⁺ channels could play an important role in pancreatic pathology, such as cystic fibrosis, pancreatitis, and pancreatic adenocarcinoma. Perhaps surprisingly, there are not so many K⁺ channels studies performed on pancreatic ducts.

Early electrophysiological studies using microelectrodes and patch-clamp methods indicated that pancreatic ducts expressed voltage- and Ca²⁺-activated K⁺-channels, consistent with maxi-K⁺ channels (BK channels), intermediate-conductance Ca²⁺-activated

*Correspondence to: Mikio Hayashi; Email: hayashmi@hirakata.kmu.ac.jp; Ivana Novak; Email: inovak@bio.ku.dk
Submitted: 06/21/2013; Revised: 08/09/2013; Accepted: 08/09/2013
<http://dx.doi.org/10.4161/chan.26100>

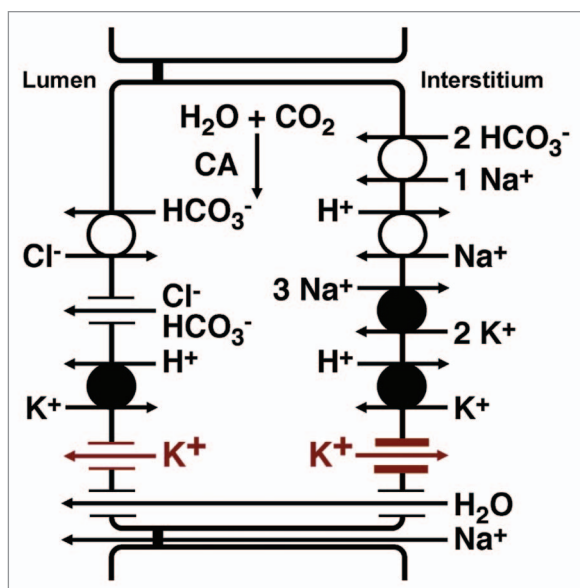

Figure 1. Model of ion transport in a pancreatic duct cell. Intracellular HCO_3^- is derived from CO_2 through the action of carbonic anhydrase (CA) and from HCO_3^- uptake via the $\text{Na}^+/\text{HCO}_3^-$ cotransporter. H^+ is extruded at the basolateral membrane by the Na^+/H^+ exchanger and H^+/K^+ pump. HCO_3^- efflux across the luminal membrane is mediated by $\text{Cl}^-/\text{HCO}_3^-$ exchangers and/or Cl^- channels, and the H^+/K^+ pump may provide a buffering/protection zone for the alkali-secreting epithelium. K^+ channels provide an exit pathway for K^+ and play a vital role in maintaining the membrane potential, which is a crucial component of the driving force for anion secretion.

K^+ channels (IK channels), and pH/HCO_3^- sensitive K^+ channels.⁶⁻¹³ Recent studies focusing on molecular candidates have shown that pancreatic ducts express the following channels that could be candidates for above functional channels: $\text{K}_{\text{Ca}}1.1$ channels coded by the *KCNMA1* and *KCNMB1* genes (α - and β -subunits of the BK channel); the $\text{K}_{\text{Ca}}3.1$ protein coded by the *KCNN4* gene (IK channel); the *KCNK5* gene ($\text{K}_{2\text{P}}5.1$); and they also express: *KCNQ1* ($\text{K}_{\text{v}}7.1$, KVLQT1), *KCNH2* ($\text{K}_{\text{v}}11.1$, HERG), *KCNH5* ($\text{K}_{\text{v}}10.2$, EAG2), *KCNT1* ($\text{K}_{\text{Ca}}4.1$, Slack), and *KCNT2* ($\text{K}_{\text{Ca}}4.2$, Slick), the functions of which remain unclear in duct cells.^{10,11,13}

It is not known whether many of these candidates are functional in pancreatic ducts or what is their localization and regulation. Therefore, their physiological and possibly pathophysiological functions have not to be confirmed. The aim of this review is to provide an overview of the above mentioned K^+ channels with respect to their electrophysiological and pharmacological characteristics and functions, as we know from other cell types, preferably in epithelia, and, where known, their identification and functions in pancreatic ducts is given (Table 1). We also address some outstanding questions and future directions in pancreatic K^+ channel research.

KCNN4 ($\text{K}_{\text{Ca}}3.1$, IK, SK4)

Tissue expression

KCNN4 coding for the $\text{K}_{\text{Ca}}3.1$ protein was cloned from the placenta and pancreas.^{14,15} Functional expression of the *KCNN4*

gene has been demonstrated in colonic crypts,¹⁶ salivary acini,¹⁷⁻¹⁹ and pancreatic ducts.^{11,13} Immunoreactivity of the $\text{K}_{\text{Ca}}3.1$ protein has also been reported in the esophagus, stomach, small intestine, proximal colonic crypts, salivary glands, luminal membrane of lacrimal gland duct cells,²⁰⁻²² and intercalated and intralobular ducts of the pancreas.^{13,23} Interestingly, $\text{K}_{\text{Ca}}3.1$ channel immunoreactivity was shown to be localized in both the basolateral and luminal membranes in pancreatic ducts and monolayer of Capan-1, a human pancreas adenocarcinoma cell line, though its expression appeared to be stronger in the luminal membrane. Consistent with this finding, the short-circuit current (I_{sc}) of the Capan-1 cell monolayer was enhanced by the $\text{K}_{\text{Ca}}3.1$ channel activator DC-EBIO in luminal or basolateral bathing solution.^{13,24} $\text{K}_{\text{Ca}}3.1$ could potentially be an important candidate for luminal K^+ channels in pancreatic ducts. Importantly, equivalent-circuit analysis revealed that luminal K^+ conductance contributed to a minimum of 10% of the total K^+ conductance in pancreatic duct cells.⁸ Moreover, stimulation of the rat pancreas with secretin caused a marked increase in K^+ concentrations in the pancreatic juice, which was equal to twice that in the plasma, indicating that K^+ was secreted.²⁵ K^+ efflux was also shown to be mediated via mucosal $\text{K}_{\text{Ca}}3.1$ channels in other epithelia, such as the distal colon, and provided, in part, the driving force for agonist-induced anion secretion.²⁶ Another example is salivary acini, in which both $\text{K}_{\text{Ca}}1.1$ and $\text{K}_{\text{Ca}}3.1$ were shown to be expressed on the apical membrane and contribute to optimal secretion.²⁷ Furthermore, H^+/K^+ -pumps were reported to be expressed on the luminal membranes of pancreatic ducts⁴ and their function, such as contributing to local epithelial protection, appeared to depend on the operation of K^+ channels.

Channel properties

Patch-clamp studies using *Xenopus* oocytes and mammalian expression systems established the basic electrophysiological and pharmacological properties of $\text{K}_{\text{Ca}}3.1$ channels.^{15,28,29} Single-channel openings were observed at both positive and negative membrane potentials, and this gating showed no significant voltage dependency. The single-channel current-voltage relationship showed weak inward rectification with conductance of 30–54 pS in heterologous expression systems. Interestingly, intermediate-conductance K^+ channels exhibited a conductance of 80 pS in rat pancreatic duct cells.¹³ One explanation for this discrepancy is that unidentified auxiliary proteins for $\text{K}_{\text{Ca}}3.1$ channels or additional *KCNN4* genes may exist in rodent cells. Regarding pharmacology, $\text{K}_{\text{Ca}}3.1$ currents were inhibited by charybdotoxin, clotrimazole, TRAM-34, and maurotoxin with K_i values of 2–28 nM, 25–150 nM, 20 nM, and 1 nM, respectively.^{15,28-32} $\text{K}_{\text{Ca}}3.1$ currents were also activated by 1-EBIO and DC-EBIO with K_d values of 15–84 μM and 0.8 μM , respectively.^{28,29,31,33}

Regulation

Regarding regulation, it is well established that $\text{K}_{\text{Ca}}3.1$ channels are activated by the Ca^{2+} /calmodulin signaling pathway. For example, heterologously expressed $\text{K}_{\text{Ca}}3.1$ channels were previously shown to be activated by submicromolar free Ca^{2+} concentrations with EC_{50} values of 0.1–0.3 μM .^{14,15,29,31} There is also strong evidence to suggest that the Ca^{2+} sensitivity of $\text{K}_{\text{Ca}}3.1$ channels is mediated by calmodulin and calmodulin

Table 1. Molecular candidates of functional K⁺ channels in pancreatic duct cells

Gene	Protein	Conductance (pS)	Blockers (K _v)	Activators (K _d)	Regulation
KCNA4	K _{Ca} 3.1	30–54 ^{15,28,29}	charybdotoxin (2–28 nM) ^{15,28,29,31} clotrimazole (25–150 nM) ^{15,28-31} TRAM-34 (20 nM) ³⁰ maurotoxin (1 nM) ³²	1-EBIO (15–84 μM) ^{28,29,31,33} DC-EBIO (0.8 μM) ³³	Ca ²⁺ ^{14,15,29,31} calmodulin ^{18,29,34} PKA ^{19,42,43} extracellular UTP ¹¹ cell swelling ^{47,48}
KCMA1	K _{Ca} 1.1	100–270 ^{50,56}	tetraethylammonium (0.14 mM) ⁵⁰ charybdotoxin (1–31 nM) ^{57,58,62} iberiotoxin (1–9 nM) ^{58,61,62} paxilline (2–9 nM) ⁵⁸⁻⁶⁰	NS1608 (2 μM) ⁶⁰ NS11021 (0.4 μM) ⁶³	membrane potential ^{7,50,56,64} Ca ²⁺ ^{7,50,56,64} PKA ^{7,56} extracellular UTP ¹¹
KCNQ1	K _v 7.1	0.7–4 ^{80,81}	chromanol 293B (10–41 μM) ^{68,82,86,87} azimilide (77 μM) ⁸⁶ XE991 (0.8 μM) ⁸⁸	L-364,373 ⁹⁰	membrane potential ⁷⁸⁻⁸¹ cAMP ⁹¹ cytosolic pH ⁸³
KCNQ1/ KCNE1	K _v 7.1/ minK	4.5–16 ^{80,81}	chromanol 293B (3–10 μM) ^{70,82,86,87} azimilide (5.6 μM) ⁸⁶ XE991 (11 μM) ⁸⁸ Mefloquine (0.9 μM) ⁸⁹	DIDS ⁸⁶ mefenamic acid ⁸⁶	membrane potential ⁷⁸⁻⁸¹ cAMP ^{91,92} cytosolic pH ⁸³
KCNH2	K _v 11.1	10–13 ¹⁰²⁻¹⁰⁴	E-4031 (7–1250 nM) ^{104,105,108-111} BeKm-1 (3–12 nM) ¹⁰⁶⁻¹¹⁰ ergotoxin (4.5–17 nM) ^{107,109} LY97241 (2.2–19 nM) ^{111,112}	mallotoxin (0.5 μM) ¹¹⁴ PD-118057 (3.1 μM) ¹¹⁵ ICA-105574 (0.5 μM) ¹⁰⁸	membrane potential ¹¹⁶ PKA ^{119,120}
KCNH5	K _v 10.2		LY97241 (1.5 μM) ¹¹³		membrane potential ⁹⁷ PKC ⁹⁷
KCNT1	K _{Ca} 4.1	180 ¹²²	bepidil (1 μM) ¹²⁵ quinidine (90 μM) ¹²⁵	bithionol (0.8 μM) ¹²⁵ niclosamide (2.9 μM) ¹²⁶ loxapine (4.4 μM) ¹²⁶ niflumic acid (2.7 mM) ¹²⁷	membrane potential ^{121,122} Ca ²⁺ ¹²¹ Na ⁺ ^{122,123} Cl ⁻ ¹²³ PKC ¹³⁰
KCNT2	K _{Ca} 4.2	140 ¹²²	quinidine ¹²² isoflurane ¹²⁸	meclufenamic acid (80 μM) ¹²⁷ flufenamic acid (1.1–1.4 mM) ^{127,129} niflumic acid (2.1 mM) ^{127,129}	membrane potential ¹²² Na ⁺ ^{122,130} Cl ⁻ ¹²² intracellular ATP ¹²² PKC ¹³⁰
KCNK5	K _{2p} 5.1	50–78 ^{133,136,137}	quinine (22 μM) ¹³³ clofilium (25 μM) ¹³⁸ bupivacaine (26 μM) ¹³⁹ ropivacaine (95 μM) ¹³⁹	halothane, isoflurane, chloroform ¹⁴⁰	extracellular pH ^{133,138,140,141} PKC ¹⁴⁰ osmolality ¹³⁸

kinase.^{18,29,34} In addition, ATP/UTP was shown to regulate K_{Ca}3.1 channels via purinergic receptors in pancreatic cell lines and rat pancreatic duct cells.^{10,12,24,35} Both P2Y₂ and P2Y₄ receptors upregulated K_{Ca}3.1 activity in the *Xenopus* oocyte expression system.¹¹ Importantly, luminal ATP/UTP, most likely delivered by secreting acini,^{36,37} was reported to stimulate ductal secretion.^{24,35,38-41}

The physiological role of K_{Ca}3.1 channels in pancreatic secretion could be also investigated with respect to secretin, which acts predominantly via the cAMP/cAMP-dependent protein kinase (PKA) signaling pathway, however, until this becomes available, we need to resort to studies on other cell types. A membrane-associated PKA has been proposed to activate K_{Ca}3.1 channels

in human erythrocytes, the T84 human colonic crypt cell line, and rat submandibular acinar cells.^{19,42,43} Interestingly, the PKA consensus phosphorylation site at serine 334 in K_{Ca} 3.1 channels was not involved in PKA-dependent activation.⁴³ In contrast to these studies, heterologously expressed K_{Ca} 3.1 channels were not affected by PKA activators and/or inhibitors,^{29,44} or were inhibited by the catalytic subunit of PKA.⁴⁵ Given these contradictory results, it is tempting to speculate that K_{Ca} 3.1 channels may be activated via the phosphorylation of a closely associated protein, the expression of which is tissue-specific. One candidate for this protein is A-kinase anchoring protein (AKAP), which is able to scaffold PKA and components of cAMP signaling pathways, including G protein-coupled receptors and ion channels.⁴⁶

In addition to transepithelial transport, K_{Ca} 3.1 channels were also shown to be stimulated by cell swelling, which triggered regulatory volume decreases.^{47,48} Notably, *KCNNA4* mRNA levels were upregulated in primary pancreatic tumors, and the growth of ductal adenocarcinoma cell lines in vitro was inhibited by blockers of K_{Ca} 3.1 channels, which indicated that these were correlated with the proliferation of pancreatic cancer.⁴⁹

KCNMA1 (K_{Ca} 1.1, Slo1, α -subunit of BK) and KCNMB (β -subunits)

Tissue expression

The *KCNMA1* coding K_{Ca} 1.1 (Slo1) protein was cloned from brain and skeletal muscle.⁵⁰ Functional expression of the *KCNMA1* gene has been demonstrated in the colon,⁵¹ salivary acini,¹⁷ pancreatic acini,⁵² and pancreatic ducts.^{11,53} The K_{Ca} 1.1 protein is located in the luminal membrane of colonic epithelia,^{51,54} salivary acini and ducts,^{27,55} and pancreatic ducts.⁵³ It is noteworthy that there was no labeling of the basolateral membrane of guinea-pig pancreatic duct cells, although the first recordings of maxi- K^+ currents were made on the basolateral membrane of rat pancreatic ducts.⁷ Venglovecz et al.⁵³ proposed that luminal K_{Ca} 1.1 channels, which are activated by bile acids in the lumen, regulate HCO_3^- secretion in pancreatic ducts. Nevertheless, experiments on K_{Ca} 1.1 regulation have also indicated that some channels may be confined to the basolateral membrane (see below). Luminal K_{Ca} 1.1 channels in the distal colon were shown to be responsible for resting and stimulated Ca^{2+} -activated K^+ secretion.⁵¹

Channel properties

K_{Ca} 1.1 channels have the largest single-channel conductance of all K^+ selective channels: 100–270 pS in symmetrical 150 mM KCl.^{50,56} Maxi- K^+ currents in isolated rat pancreatic duct cells had a conductance of 170–180 pS.^{7,13} Regarding pharmacology, the α -subunit of K_{Ca} 1.1 was inhibited by tetraethylammonium, charybdotoxin, iberiotoxin, and paxilline with K_i values of 0.14 mM, 1–31 nM, 1–9 nM, and 2–9 nM, respectively.^{50,57–62} The α -subunit of K_{Ca} 1.1 was also activated by NS1608 and NS11021 with K_d values of 2 μ M and 0.4 μ M, respectively.^{60,63} Interestingly, dehydrosoyasaponin I (DHS-I) activated the α -subunit of K_{Ca} 1.1 only if co-expressed with the β 1-subunit, an auxiliary protein for K_{Ca} 1.1 channels.⁵⁷

Regulation

Significant diversity has been reported in the functional characteristics of K_{Ca} 1.1 channels. It is well established that K_{Ca} 1.1 channels are activated by membrane depolarization alone, intracellular Ca^{2+} alone, or synergistically by depolarization and Ca^{2+} .^{7,50,56,64} The single-channel open probability of K_{Ca} 1.1 channels markedly increased when the cytoplasmic face of a patch membrane was exposed to 10 μ M Ca^{2+} and voltage was changed over a range of –60 to +80 mV. Under these conditions, the half-maximal voltage ($V_{1/2}$) was +23 mV in 10 μ M Ca^{2+} ;⁵⁰ however, these were unphysiological conditions for pancreatic ducts. Importantly, maxi- K^+ channels on pancreatic duct cells were activated by much lower Ca^{2+} concentrations. For example, maxi- K^+ channels exposed to 3 μ M Ca^{2+} reached $V_{1/2}$ at –4 mV.⁷ This difference indicated that the β -subunit exists in pancreatic duct cells. Maxi- K^+ channels on *Xenopus* oocytes that heterologously expressed both the α – and β 1-subunits of K_{Ca} 1.1 proteins were about 10-fold more sensitive to activation by voltage and Ca^{2+} concentration than channels composed of the α -subunit alone.⁵⁷ Indeed, *KCNMB1* coding the β 1 subunit was detected in isolated pancreatic ducts.¹¹

Interestingly, UTP was shown to inhibit K_{Ca} 1.1 channels via the P2Y₂ receptor,¹¹ and appeared to lead to a decrease in secretion. The basolateral application of ATP/UTP inhibited K^+ conductance in rat duct cells and secretion in guinea-pig ducts and human duct cell monolayers.^{35,39,40} These results collectively indicated that P2Y₂ receptors on the basolateral membrane appeared to downregulate secretion via K_{Ca} 1.1 channels in the ductal system.

Regarding the cAMP/PKA signaling pathway, cAMP-dependent phosphorylation can also activate maxi- K^+ channels on pancreatic duct cells.⁷ The functional response of K_{Ca} 1.1 channels to PKA phosphorylation depends on the splice-variant of the α -subunit. For example, PKA was shown to activate the ZERO splice variant, whereas PKA inhibited the STREX variant. PKA activation of the ZERO variant requires a conserved C-terminal PKA site.⁶⁵ Indeed, the ZERO splice variant has been shown to conduct adrenaline-induced K^+ secretion in the distal colon.⁶⁶

KCNQ1 (K_v 7.1, KVLQT1) and KCNE1 (minK)

Tissue expression

The *KCNQ1* coding K_v 7.1 protein was cloned from the heart.⁶⁷ Functional expression of the *KCNQ1* gene has also been demonstrated in the kidney, stomach, small intestine, colon,^{68–71} pancreatic acini,^{69,72,73} and pancreatic ducts.¹³ Immunoreactivity of the K_v 7.1 protein was reported in the parietal cells of the stomach, in the basolateral membrane of small intestinal and colonic crypt cells,^{69,74,75} and in acinar and duct cells of the pancreas.^{13,69} K_v 7.1 resides in the tubulovesicular and canalicular membranes of gastric parietal cells together with H^+ – K^+ -pumps and participates in gastric acid secretion.^{71,74,75} K_v 7.1 was localized in the luminal membrane of pancreatic duct cells,¹³ and may be involved in cell volume regulation during purinergic stimulation in epithelial transport,^{76,77} and/or may potentially be associated with H^+ – K^+ -pumps expressed by pancreatic ducts.⁴

The $K_{v7.1}$ protein can assemble with the *KCNE* family of regulatory β -subunits to fulfill various physiological functions. For example, minK coded by the *KCNE1* gene has been shown to modify $K_{v7.1}$ activity by increasing unitary conductance, slowing activation, causing a right shift in the voltage dependence of activation, and modulating pharmacology.^{78–82} It is worth noting that the acidification of cytosolic pH increased $K_{v7.1}$ –minK, but decreased $K_{v7.1}$ currents, whereas alkalization decreased $K_{v7.1}$ –minK, but increased $K_{v7.1}$ currents.⁸³ Indeed, the whole pancreas expresses *KCNE1* and *KCNE2* genes.^{84,85} The $K_{v7.1}$ current was shown to be strongly diminished and membrane targeting of the $K_{v7.1}$ protein was impaired in acinar cells in *KCNE1* knockout mice.⁶⁹ The expression and function of *KCNE* in duct cells has not yet been investigated.

Channel properties

$K_{v7.1}$ channels have very small conductance. Noise analysis revealed estimated single-channel conductances of 0.7–4 pS.^{80,81} Small conductance K^+ channels had 1 pS and were inhibited by chromanol 293B, a $K_{v7.1}$ blocker, in the basolateral membrane of rat pancreatic acinar cells.⁷³ Chromanol 293B inhibited α -subunit of $K_{v7.1}$ with K_i values of 10–41 μ M in *Xenopus* oocytes and mammalian expression systems.^{68,82,86,87} Importantly, *KCNE* β -subunits increase the sensitivity of $K_{v7.1}$ to chromanol 293B. K_i values for $K_{v7.1}/KCNE1$, $K_{v7.1}/KCNE2$ and $K_{v7.1}/KCNE3$ were 3–10 μ M, 0.4 μ M, and 3–4 μ M, respectively.^{68,70,82,86,87} Voltage-gated K^+ currents in pancreatic acinar cells were shown to be inhibited by chromanol 293B with a K_i value of 3 μ M.⁷² This result supports voltage-gated K^+ channels being composed of $K_{v7.1}$ and *KCNE1* β -subunit in acinar cells. Azimilide inhibited $K_{v7.1}$ and $K_{v7.1}/KCNE1$ in the same manner as chromanol 293B with K_i values of 77 μ M and 5.6 μ M, respectively.⁸⁶ In contrast, XE991 inhibited $K_{v7.1}$ and $K_{v7.1}/KCNE1$ with K_i values of 0.8 μ M and 11 μ M, respectively.⁸⁸ Mefloquine inhibited $K_{v7.1}/KCNE1$ with a K_i value of 0.9 μ M.⁸⁹ DIDS and mefenamic acid activated $K_{v7.1}/KCNE1$, but not $K_{v7.1}$.⁸⁶ On the other hand, L-364,373 activated $K_{v7.1}$, but did not affect $K_{v7.1}/KCNE1$.⁹⁰

Regulation

Regarding regulation, voltage-gated $K_{v7.1}$ channels are known to be regulated by the cAMP signaling pathway.⁹¹ In addition, AKAPs are required for cAMP regulation of recombinant $K_{v7.1}$ channels in mammalian cell lines.⁹² Interestingly, a K^+ current was elicited by cAMP stimulation in CFTR-transfected, but not untransfected CFPAC-1 cells derived from a cystic fibrosis patient with deletion in Phe-508 in CFTR.⁹³ AKAPs also mediate PKA compartmentalization with CFTR;⁹⁴ therefore, these findings imply that functional CFTR regulates the $K_{v7.1}$ channel, presumably in the luminal membrane of pancreatic duct cells.

***KCNH2* ($K_{v11.1}$, HERG) and *KCNH5* ($K_{v10.2}$, EAG2)**

Tissue expression

The *KCNH2* coding $K_{v11.1}$ (HERG) protein was isolated from the hippocampal cDNA library.⁹⁵ Functional expression of the *KCNH2* gene has been demonstrated in colon carcinoma cells.⁹⁶ Immunoreactivity of the $K_{v11.1}$ protein was also reported in colon carcinoma cells⁹⁶ and the luminal membrane

of pancreatic duct cells.¹³ The *KCNH5* coding $K_{v10.2}$ (EAG2) protein was identified in the thalamus and was expressed in the brain, testes, skeletal muscle, heart, placenta, lung, liver, and at low levels in the kidney and whole pancreas.^{97,98} Notably, $K_{v10.2}$ was shown to promote medulloblastoma tumor progression by regulating cell volume dynamics.⁹⁹ *KCNH2* and *KCNH5* are clearly expressed in rodent and human pancreatic duct cells.¹³ However, the physiological or potentially pathophysiological role of $K_{v11.1}$ and $K_{v10.2}$ channels remains unclear. The related $K_{v10.1}$ (*KCNH1*) channel has been shown to be upregulated in several cancers including pancreatic cancer, based on studies of human pancreatic adenocarcinoma cell lines.^{100,101}

Channel properties

$K_{v11.1}$ channels have small conductance of 10–13 pS.^{102–104} Regarding pharmacology, $K_{v11.1}$ was inhibited by E-4031, BeKm-1, and ergotoxin with K_i values of 7–1250 nM, 3–12 nM, and 4.5–17 nM, respectively.^{104–111} $K_{v11.1}$ channels formed with *KCNE2* were about 2-fold more sensitive to E-4031.¹⁰⁴ LY97241 was shown to inhibit $K_{v10.2}$ and $K_{v11.1}$ currents with K_i values of 1.5 μ M and 2.2–19 nM, respectively.^{111–113} $K_{v11.1}$ currents were also activated by mallotoxin, PD-118057, and ICA-105574 with K_d values of 0.5 μ M, 3.1 μ M, and 0.5 μ M, respectively.^{108,114,115}

Regulation

$K_{v11.1}$ currents were activated at voltages more positive than –50 mV and $V_{1/2}$ was –15.1 mV,¹¹⁶ whereas $K_{v10.2}$ currents were activated at around –100 mV and $V_{1/2}$ was –35.5 mV.⁹⁷ However, a 14–3–3 protein was associated with $K_{v11.1}$ in a phosphorylation-dependent manner at specific PKA sites and shifted $V_{1/2}$ in a hyperpolarizing direction by –11.1 mV.¹¹⁷ $K_{v11.1}$ may exist in a macromolecular signaling complex that includes 14–3–3 proteins and possibly AKAPs.¹¹⁸ Importantly, the $K_{v11.1}$ protein can also assemble with *KCNE1* or *KCNE2* regulatory β -subunits.^{103,104} Regarding inhibition, phorbol 12-myristate 13-acetate (PMA), an activator of protein kinase C (PKC), produced a potent dose-dependent block of $K_{v10.2}$ or $K_{v11.1}$ currents.^{97,119} In addition, $K_{v11.1}$ currents were reduced by the cAMP-specific phosphodiesterase inhibitor Ro-20–1724 or the adenylate cyclase activator forskolin, which were shown to result in increased cAMP levels and PKA stimulation.¹²⁰

***KCNT1* ($K_{Ca4.1}$, Slo2.2, Slack) and *KCNT2* ($K_{Ca4.2}$, Slo2.1, Slick)**

Tissue expression

KCNT1 ($K_{Ca4.1}$, Slo2.2, or Slack), which encodes for the Na^+ -activated K^+ channel, was isolated from the brain cDNA library.¹²¹ *KCNT1* and *KCNT2* ($K_{Ca4.2}$, Slo2.1, or Slick) are expressed in the heart, kidney and testis, as well as in the brain.^{121–123} The functional expression of $K_{Ca4.1}$ has been demonstrated in the basolateral membrane of the thick ascending limbs of Henle's loop.¹²⁴ Pancreatic duct cells also expressed *KCNT1* and *KCNT2*.¹³ Interestingly, the expression pattern of *KCNT1* and *KCNT2* was different between Capan-1 cells expressing functional CFTR channels and CFPAC-1 cells derived from a cystic fibrosis patient with a mutation in CFTR. Capan-1 cells express *KCNT1*, but not *KCNT2*, while CFPAC-1 cells express *KCNT2*,

but not *KCNT1*. This discrepancy indicates that the expression of *KCNT1* and *KCNT2* channels is in some way associated with the expression of functional CFTR. However, the function of these K⁺ channels in pancreatic duct cells remains to be investigated.

Channel properties

K_{Ca}4.1 and K_{Ca}4.2 channels have large conductances of 180 pS and 140 pS in symmetrical 130 mM KCl.¹²² In the basolateral membrane of the thick ascending limbs of Henle's loop, Na⁺-activated K⁺ channels had a conductance of 140–180 pS.¹²⁴ Regarding pharmacology, K_{Ca}4.1 was inhibited by bepridil and quinidine with K_i values of 1 μM and 90 μM, respectively.¹²⁵ K_{Ca}4.1 was activated by bithionol, niclosamide, loxapine, and niflumic acid with K_d values of 0.8 μM, 2.9 μM, 4.4 μM, and 2.7 mM, respectively.^{125–127} K_{Ca}4.2 was inhibited by 1 mM quinidine and isoflurane,^{122,128} and was activated by meclofenamic acid, flufenamic acid, and niflumic acid with K_d values of 80 μM, 1.1–1.4 mM, and 2.1 mM, respectively.^{127,129}

Regulation

K_{Ca}4.1 was shown to be unusually inhibited by intracellular Ca²⁺ at 1 μM.¹²¹ However, K_{Ca}4.1 may co-assemble with K_{Ca}1.1 subunits to generate Ca²⁺-activated K⁺ channels.¹²¹ K_{Ca}4.1 and K_{Ca}4.2 channels were reported to be activated by intracellular Na⁺ and K_d values of 41 mM and 89 mM in the presence of 30 mM internal Cl⁻, respectively.¹²² These channels were also activated by intracellular Cl⁻ or synergistically by Na⁺ and Cl⁻.^{122,123} Intracellular ATP inhibited K_{Ca}4.2 directly, via the presence of a consensus ATP binding motif.¹²² A similar ATP binding motif has not been demonstrated in the K_{Ca}4.1 sequences.^{122,124} Interestingly, the PKC activator PMA increased K_{Ca}4.1 currents, but inhibited K_{Ca}4.2 currents.¹³⁰

KCNK5 (K_{2p}5.1, TASK-2)

Tissue expression

Two-pore domain K⁺ channels (K_{2p}) generate background K⁺ currents over the whole membrane potential range.¹³¹ The pH-sensitive K_{2p} subunits (TALK-1, TALK-2 and TASK-2) were shown to be expressed in pancreatic acini.¹³² An electrophysiological study indicated that TASK-2 was expressed in HPAF, a human pancreatic ductal adenocarcinoma cell line.¹⁰ *KCNK5* coding TASK-2 (K_{2p}5.1) was isolated from the brain cDNA library.¹³³ *KCNK5* is expressed in the kidney, liver, stomach, small intestine, colon, and pancreatic acinus.^{132–134} The functional expression of K_{2p}5.1 has been demonstrated in kidney proximal convoluted tubule cells, which could be involved in volume regulation and HCO₃⁻ transport.¹³⁵ Clofilium-sensitive K⁺ conductance, possibly K_{2p}5.1, was located in the luminal membrane of the monolayer of HPAF.¹⁰ pH-sensitive K⁺ channels on the luminal membrane of pancreatic duct cells may be physiologically relevant in terms of maintaining the electrical driving force for electrogenic HCO₃⁻ secretion and providing an exit pathway for K⁺ secretion.

Channel properties

K_{2p}5.1 channels have an intermediate conductance of 50–78 pS.^{133,136,137} Regarding pharmacology, K_{2p}5.1 was inhibited by quinine, clofilium, bupivacaine, and ropivacaine with K_i values

of 22 μM, 25 μM, 26 μM, and 95 μM, respectively.^{133,138,139} K_{2p}5.1 was activated by halothane, isoflurane, and chloroform, which are volatile anesthetics.¹⁴⁰

Regulation

K_{2p}5.1 is very sensitive to extracellular pH in the physiological range, with a pK_a value of 7.5–8.3.^{133,138,140,141} Phorbol 12,13-dibutyrate and PMA, activators of PKC, were shown to potentiate K_{2p}5.1 currents in *Xenopus* oocytes.¹⁴⁰ Extracellular ATP activated TASK-like channels (K_{2p}3.1 and/or K_{2p}5.1), possibly via the P2Y₁₁ receptor in thoracic aorta myocytes.¹⁴² P2Y₁₁ receptors were reported to be expressed on the basolateral membrane of canine pancreatic duct epithelia, which increased cAMP and I_{sc}.¹⁴³ The K_{2p}5.1 channel is also osmosensitive and participates in cell volume regulation.¹³⁸ Therefore, pH-sensitive K⁺ channels may be important on both the luminal (alkaline) and basolateral (acid) membranes of pancreatic ducts.

Potassium Channels in Pancreatic Cancer

Ion channels have been associated with the malignant phenotype of cancer cells, as well as contributing to virtually all basic cellular processes, including crucial roles in maintaining tissue homeostasis such as proliferation, differentiation, and apoptosis.¹⁴⁴ Several potassium channels have been suggested as the hallmarks of cancer,¹⁴⁵ including pancreatic duct adenocarcinoma.¹⁴⁴ For example, K_{Ca}3.1 channels have been correlated with the proliferation of pancreatic cancer.⁴⁹ In addition, the expression of G protein-activated inward rectifier potassium channel 1 (K_{ir}3.1) was markedly higher in pancreatic adenocarcinomas than in a normal pancreas, whereas K_v1.3 expression was decreased in pancreatic adenocarcinomas. Downregulation in the expression of K_v1.3 has been associated with metastatic tumors.¹⁴⁶ K_v1.5 was also shown to be highly expressed in pancreatic adenocarcinomas.¹⁴⁷ Furthermore, a specific monoclonal antibody that inhibits the function of K_v10.1 (EAG1) reduced tumor growth of BxPC3, a human pancreas adenocarcinoma cell line, which implicates this channel in cancer progression.¹⁰⁰ Altered pH homeostasis is known to be one of the key hallmarks of cancer.^{148,149} Thus, pH-sensitive K_{2p} channels may also play a role in pancreatic adenocarcinoma. The human duct adenocarcinoma cell line, HPAF cells, were reported to express K_{2p}5.1 channels.¹⁰ However, its contribution to cancer progression is still unknown. Although further studies on K⁺ channels in pancreatic cancer must be performed, some candidates, such as K_v10.1, already have the potential to be diagnostic tools and therapeutic targets.¹⁰¹

Concluding Remarks

This review described the current status on the molecular basis for a number of K⁺ channels found in pancreatic ducts. Electrophysiological studies on ducts and duct cells using microelectrode, patch-clamp, and Ussing chamber methods showed how some of these K⁺ channels contribute to physiological processes in ductal secretion by providing the driving forces for anion transport and as partial accompanying partners in

secretion. Future studies are needed to verify the localization of K⁺ channels to a polarized ductal epithelium and affirm their physiological function in secretion or associated cell processes such as cell volume regulation, as well as their participation in cell proliferation and apoptosis. The pancreas and especially the ductal epithelium are involved in a number of diseases including cystic fibrosis and pancreatitis.¹⁵⁰ Some target therapies should include K⁺ channel openers to maintain or upregulate pancreatic secretion. Our knowledge regarding the role of K⁺ channels in duct cell homeostasis remains relatively sparse. Because some K⁺ channels are being regarded as the hallmark of cancer progression and emerging studies on pancreatic adenocarcinoma

foreshadow similar trends, more knowledge is required in this area before specific K⁺ channel openers or inhibitors can be used in the treatment of pancreatic diseases.

Disclosure of Potential Conflicts of Interest

No potential conflicts of interest were disclosed.

Acknowledgments

This work was supported by the Pancreas Research Foundation of Japan, JSPS KAKENHI Grant Number 24790226, the Lundbeck Foundation, and Danish Council for Independent Research Natural Sciences (10–085217).

References

- Steward MC, Ishiguro H, Case RM. Mechanisms of bicarbonate secretion in the pancreatic duct. *Annu Rev Physiol* 2005; 67:377-409; PMID:15709963; <http://dx.doi.org/10.1146/annurev.physiol.67.031103.153247>
- Novak I. Purinergic signalling in epithelial ion transport: regulation of secretion and absorption. *Acta Physiol (Oxf)* 2011; 202:501-22; PMID:21073662; <http://dx.doi.org/10.1111/j.1748-1716.2010.02225.x>
- Lee MG, Ohana E, Park HW, Yang D, Muallem S. Molecular mechanism of pancreatic and salivary gland fluid and HCO₃ secretion. *Physiol Rev* 2012; 92:39-74; PMID:22298651; <http://dx.doi.org/10.1152/physrev.00011.2011>
- Novak I, Wang J, Henriksen KL, Haanes KA, Krabbe S, Nitschke R, Hede SE. Pancreatic bicarbonate secretion involves two proton pumps. *J Biol Chem* 2011; 286:280-9; PMID:20978133; <http://dx.doi.org/10.1074/jbc.M110.136382>
- Heitzmann D, Warth R. Physiology and pathophysiology of potassium channels in gastrointestinal epithelia. *Physiol Rev* 2008; 88:1119-82; PMID:18626068; <http://dx.doi.org/10.1152/physrev.00020.2007>
- Novak I, Greger R. Electrophysiological study of transport systems in isolated perfused pancreatic ducts: properties of the basolateral membrane. *Pflügers Arch* 1988; 411:58-68; PMID:3353213; <http://dx.doi.org/10.1007/BF00581647>
- Gray MA, Greenwell JR, Garton AJ, Argent BE. Regulation of maxi-K⁺ channels on pancreatic duct cells by cyclic AMP-dependent phosphorylation. *J Membr Biol* 1990; 115:203-15; PMID:1695685; <http://dx.doi.org/10.1007/BF01868636>
- Novak I, Greger R. Effect of bicarbonate on potassium conductance of isolated perfused rat pancreatic ducts. *Pflügers Arch* 1991; 419:76-83; PMID:1945765; <http://dx.doi.org/10.1007/BF00373750>
- Ishiguro H, Steward MC, Sohma Y, Kubota T, Kitagawa M, Kondo T, Case RM, Hayakawa T, Naruse S. Membrane potential and bicarbonate secretion in isolated interlobular ducts from guinea-pig pancreas. *J Gen Physiol* 2002; 120:617-28; PMID:12407075; <http://dx.doi.org/10.1085/jgp.20028631>
- Fong P, Argent BE, Guggino WB, Gray MA. Characterization of vectorial chloride transport pathways in the human pancreatic duct adenocarcinoma cell line HPAF. *Am J Physiol Cell Physiol* 2003; 285:C433-45; PMID:12711595; <http://dx.doi.org/10.1152/ajpcell.00509.2002>
- Hede SE, Amstrup J, Klaerke DA, Novak I. P2Y₂ and P2Y₄ receptors regulate pancreatic Ca²⁺-activated K⁺ channels differently. *Pflügers Arch* 2005; 450:429-36; PMID:16075244; <http://dx.doi.org/10.1007/s00424-005-1433-3>
- Jung SR, Kim K, Hille B, Nguyen TD, Koh DS. Pattern of Ca²⁺ increase determines the type of secretory mechanism activated in dog pancreatic duct epithelial cells. *J Physiol* 2006; 576:163-78; PMID:16857709; <http://dx.doi.org/10.1113/jphysiol.2006.114876>
- Hayashi M, Wang J, Hede SE, Novak I. An intermediate-conductance Ca²⁺-activated K⁺ channel is important for secretion in pancreatic duct cells. *Am J Physiol Cell Physiol* 2012; 303:C151-9; PMID:22555847; <http://dx.doi.org/10.1152/ajpcell.00089.2012>
- Joiner WJ, Wang LY, Tang MD, Kaczmarek LK. hSK4, a member of a novel subfamily of calcium-activated potassium channels. *Proc Natl Acad Sci U S A* 1997; 94:11013-8; PMID:9380751; <http://dx.doi.org/10.1073/pnas.94.20.11013>
- Ishii TM, Silvia C, Hirschberg B, Bond CT, Adelman JP, Maylie J. A human intermediate conductance calcium-activated potassium channel. *Proc Natl Acad Sci U S A* 1997; 94:11651-6; PMID:9326665; <http://dx.doi.org/10.1073/pnas.94.21.11651>
- Warth R, Hamm K, Bleich M, Kunzelmann K, von Hahn T, Schreiber R, Ullrich E, Mengel M, Trautmann N, Kindl P, et al. Molecular and functional characterization of the small Ca²⁺-regulated K⁺ channel (rSK4) of colonic crypts. *Pflügers Arch* 1999; 438:437-44; PMID:10519135; <http://dx.doi.org/10.1007/s004240051059>
- Nehrke K, Quinn CC, Begenisich T. Molecular identification of Ca²⁺-activated K⁺ channels in parotid acinar cells. *Am J Physiol Cell Physiol* 2003; 284:C535-46; PMID:12388098; <http://dx.doi.org/10.1152/ajpcell.00044.2002>
- Takahata T, Hayashi M, Ishikawa T. SK4/IK1-like channels mediate TEA-insensitive, Ca²⁺-activated K⁺ currents in bovine parotid acinar cells. *Am J Physiol Cell Physiol* 2003; 284:C127-44; PMID:12388063; <http://dx.doi.org/10.1152/ajpcell.00250.2002>
- Hayashi M, Kunii C, Takahata T, Ishikawa T. ATP-dependent regulation of SK4/IK1-like currents in rat submandibular acinar cells: possible role of cAMP-dependent protein kinase. *Am J Physiol Cell Physiol* 2004; 286:C635-46; PMID:14602578; <http://dx.doi.org/10.1152/ajpcell.00283.2003>
- Furness JB, Robbins HL, Selmer IS, Hunne B, Chen MX, Hicks GA, Moore S, Neylon CB. Expression of intermediate conductance potassium channel immunoreactivity in neurons and epithelial cells of the rat gastrointestinal tract. *Cell Tissue Res* 2003; 314:179-89; PMID:14513356; <http://dx.doi.org/10.1007/s00441-003-0808-z>
- Joiner WJ, Basavappa S, Vidyasagar S, Nehrke K, Krishnan S, Binder HJ, Boulpaep EL, Rajendran VM. Active K⁺ secretion through multiple K_{Ca}-type channels and regulation by IK_{Ca} channels in rat proximal colon. *Am J Physiol Gastrointest Liver Physiol* 2003; 285:G185-96; PMID:12606302
- Ubels JL, Hoffman HM, Srikanth S, Resau JH, Webb CP. Gene expression in rat lacrimal gland duct cells collected using laser capture microdissection: evidence for K⁺ secretion by duct cells. *Invest Ophthalmol Vis Sci* 2006; 47:1876-85; PMID:16638994; <http://dx.doi.org/10.1167/iovs.05-0363>
- Thompson-Vest N, Shimizu Y, Hunne B, Furness JB. The distribution of intermediate-conductance, calcium-activated, potassium (IK) channels in epithelial cells. *J Anat* 2006; 208:219-29; PMID:16441566; <http://dx.doi.org/10.1111/j.1469-7580.2006.00515.x>
- Wang J, Haanes KA, Novak I. Purinergic regulation of CFTR and Ca²⁺-activated Cl⁻ channels and K⁺ channels in human pancreatic duct epithelium. *Am J Physiol Cell Physiol* 2013; 304:C673-84; PMID:23364268; <http://dx.doi.org/10.1152/ajpcell.00196.2012>
- Sewell WA, Young JA. Secretion of electrolytes by the pancreas of the anaesthetized rat. *J Physiol* 1975; 252:379-96; PMID:1206529
- Nanda Kumar NS, Singh SK, Rajendran VM. Mucosal potassium efflux mediated via K_{Ca}4 channels provides the driving force for electrogenic anion secretion in colon. *Am J Physiol Gastrointest Liver Physiol* 2010; 299:G707-14; PMID:20616305; <http://dx.doi.org/10.1152/ajpgi.00101.2010>
- Almasy J, Won JH, Begenisich TB, Yule DI. Apical Ca²⁺-activated potassium channels in mouse parotid acinar cells. *J Gen Physiol* 2012; 139:121-33; PMID:22291145; <http://dx.doi.org/10.1085/jgp.201110718>
- Jensen BS, Strøbæk D, Christophersen P, Jørgensen TD, Hansen C, Silahtaroglu A, Olesen SP, Ahring PK. Characterization of the cloned human intermediate-conductance Ca²⁺-activated K⁺ channel. *Am J Physiol* 1998; 275:C848-56; PMID:9730970
- von Hahn T, Thiele I, Zingaro L, Hamm K, Garcia-Alzamora M, Köttgen M, Bleich M, Warth R. Characterisation of the rat SK4/IK1 K⁺ channel. *Cell Physiol Biochem* 2001; 11:219-30; PMID:11509830; <http://dx.doi.org/10.1159/000051936>
- Wulff H, Miller MJ, Hänsel W, Grissmer S, Cahalan MD, Chandry KG. Design of a potent and selective inhibitor of the intermediate-conductance Ca²⁺-activated K⁺ channel, *IKCa1*: a potential immunosuppressant. *Proc Natl Acad Sci U S A* 2000; 97:8151-6; PMID:10884437; <http://dx.doi.org/10.1073/pnas.97.14.8151>
- Wulf A, Schwab A. Regulation of a calcium-sensitive K⁺ channel (cIK1) by protein kinase C. *J Membr Biol* 2002; 187:71-9; PMID:12029379; <http://dx.doi.org/10.1007/s00232-001-0149-3>
- Castle NA, London DO, Creech C, Fajloun Z, Stocker JW, Sabatier JM. Maurotoxin: a potent inhibitor of intermediate conductance Ca²⁺-activated potassium channels. *Mol Pharmacol* 2003; 63:409-18; PMID:12527813; <http://dx.doi.org/10.1124/mol.63.2.409>

33. Singh S, Syme CA, Singh AK, Devor DC, Bridges RJ. Benzimidazolone activators of chloride secretion: potential therapeutics for cystic fibrosis and chronic obstructive pulmonary disease. *J Pharmacol Exp Ther* 2001; 296:600-11; PMID:11160649
34. Fanger CM, Ghanshani S, Logsdon NJ, Rauer H, Kalman K, Zhou J, Beckingham K, Chandry KG, Cahalan MD, Aiyar J. Calmodulin mediates calcium-dependent activation of the intermediate conductance K_{Ca} channel, *IKCa1*. *J Biol Chem* 1999; 274:5746-54; PMID:10026195; <http://dx.doi.org/10.1074/jbc.274.9.5746>
35. Hede SE, Amstrup J, Christoffersen BC, Novak I. Purinoceptors evoke different electrophysiological responses in pancreatic ducts. P2Y inhibits K^{+} conductance, and P2X stimulates cation conductance. *J Biol Chem* 1999; 274:31784-91; PMID:10542200; <http://dx.doi.org/10.1074/jbc.274.45.31784>
36. Sørensen CE, Novak I. Visualization of ATP release in pancreatic acini in response to cholinergic stimulus. Use of fluorescent probes and confocal microscopy. *J Biol Chem* 2001; 276:32925-32; PMID:11387334; <http://dx.doi.org/10.1074/jbc.M103313200>
37. Haanes KA, Novak I. ATP storage and uptake by isolated pancreatic zymogen granules. *Biochem J* 2010; 429:303-11; PMID:20441565; <http://dx.doi.org/10.1042/BJ20091337>
38. Hug M, Pahl C, Novak I. Effect of ATP, carbachol and other agonists on intracellular calcium activity and membrane voltage of pancreatic ducts. *Pflügers Arch* 1994; 426:412-8; PMID:7517031; <http://dx.doi.org/10.1007/BF00388304>
39. Ishiguro H, Naruse S, Kitagawa M, Hayakawa T, Case RM, Steward MC. Luminal ATP stimulates fluid and HCO_3^{-} secretion in guinea-pig pancreatic duct. *J Physiol* 1999; 519:551-8; PMID:10457070; <http://dx.doi.org/10.1111/j.1469-7793.1999.0551m.x>
40. Szűcs A, Demeter I, Burghardt B, Óvári G, Case RM, Steward MC, Varga G. Vectorial bicarbonate transport by Capan-1 cells: a model for human pancreatic ductal secretion. *Cell Physiol Biochem* 2006; 18:253-64; PMID:17167230; <http://dx.doi.org/10.1159/000097672>
41. Wang J, Novak I. Ion transport in human pancreatic duct epithelium, Capan-1 cells, is regulated by secretin, VIP, acetylcholine, and purinergic receptors. *Pancreas* 2013; 42:452-60; PMID:22982819; <http://dx.doi.org/10.1007/s12201-013-0302-3>
42. Pellegrino M, Pellegrini M. Modulation of Ca^{2+} -activated K^{+} channels of human erythrocytes by endogenous cAMP-dependent protein kinase. *Pflügers Arch* 1998; 436:749-56; PMID:9716709; <http://dx.doi.org/10.1007/s004240050698>
43. Gerlach AC, Gangopadhyay NN, Devor DC. Kinase-dependent regulation of the intermediate conductance, calcium-dependent potassium channel, hIK1. *J Biol Chem* 2000; 275:585-98; PMID:10617655; <http://dx.doi.org/10.1074/jbc.275.1.585>
44. Schröder RL, Jensen BS, Strøbæk D, Olesen SP, Christophersen P. Activation of the human, intermediate-conductance, Ca^{2+} -activated K^{+} channel by methylxanthines. *Pflügers Arch* 2000; 440:809-18; PMID:11041545; <http://dx.doi.org/10.1007/s004240000364>
45. Neylon CB, D'Souza T, Reinhart PH. Protein kinase A inhibits intermediate conductance Ca^{2+} -activated K^{+} channels expressed in *Xenopus* oocytes. *Pflügers Arch* 2004; 448:613-20; PMID:15243742; <http://dx.doi.org/10.1007/s00424-004-1302-5>
46. Dessauer CW. Adenylyl cyclase---A-kinase anchoring protein complexes: the next dimension in cAMP signaling. *Mol Pharmacol* 2009; 76:935-41; PMID:19684092; <http://dx.doi.org/10.1124/mol.109.059345>
47. Vadorpe DH, Shmukler BE, Jiang L, Lim B, Maylie J, Adelman JP, de Franceschi L, Cappellini MD, Brugnara C, Alper SL. cDNA cloning and functional characterization of the mouse Ca^{2+} -gated K^{+} channel, mIK1. Roles in regulatory volume decrease and erythroid differentiation. *J Biol Chem* 1998; 273:21542-53; PMID:9705284; <http://dx.doi.org/10.1074/jbc.273.34.21542>
48. Hoffmann EK, Lambert IH, Pedersen SF. Physiology of cell volume regulation in vertebrates. *Physiol Rev* 2009; 89:193-277; PMID:19126758; <http://dx.doi.org/10.1152/physrev.00037.2007>
49. Jäger H, Dreker T, Buck A, Giehl K, Gress T, Grissmer S. Blockage of intermediate-conductance Ca^{2+} -activated K^{+} channels inhibit human pancreatic cancer cell growth in vitro. *Mol Pharmacol* 2004; 65:630-8; PMID:14978241; <http://dx.doi.org/10.1124/mol.65.3.630>
50. Butler A, Tsunoda S, McCobb DP, Wei A, Salkoff L. *mSlo*, a complex mouse gene encoding "maxi" calcium-activated potassium channels. *Science* 1993; 261:221-4; PMID:7687074; <http://dx.doi.org/10.1126/science.7687074>
51. Sausbier M, Matos JE, Sausbier U, Beranek G, Arntz C, Neuhuber W, Ruth P, Leipziger J. Distal colonic K^{+} secretion occurs *via* BK channels. *J Am Soc Nephrol* 2006; 17:1275-82; PMID:16571783; <http://dx.doi.org/10.1681/ASN.2005101111>
52. Oshiro T, Takahashi H, Ohsaga A, Ebihara S, Sasaki H, Maruyama Y. Delayed expression of large conductance K^{+} channels reshaping agonist-induced currents in mouse pancreatic acinar cells. *J Physiol* 2005; 563:379-91; PMID:15611028; <http://dx.doi.org/10.1113/jphysiol.2004.077834>
53. Venglovecz V, Hegyi P, Rakonczay Z Jr., Tiszlavicz L, Nardi A, Grunnet M, Gray MA. Pathophysiological relevance of apical large-conductance Ca^{2+} -activated potassium channels in pancreatic duct epithelial cells. *Gut* 2011; 60:361-9; PMID:20940280; <http://dx.doi.org/10.1136/gut.2010.214213>
54. Hay-Schmidt A, Grunnet M, Abrahamse SL, Knaus HG, Klaefer DA. Localization of Ca^{2+} -activated big-conductance K^{+} channels in rabbit distal colon. *Pflügers Arch* 2003; 446:61-8; PMID:12690464
55. Nakamoto T, Romanenko VG, Takahashi A, Begensich T, Melvin JE. Apical maxi-K ($K_{Ca}1.1$) channels mediate K^{+} secretion by the mouse submandibular exocrine gland. *Am J Physiol Cell Physiol* 2008; 294:C810-9; PMID:18216162; <http://dx.doi.org/10.1152/ajpcell.00511.2007>
56. Salkoff L, Butler A, Ferreira G, Santi C, Wei A. High-conductance potassium channels of the SLO family. *Nat Rev Neurosci* 2006; 7:921-31; PMID:17115074; <http://dx.doi.org/10.1038/nrn1992>
57. McManus OB, Helms LM, Pallanck L, Ganetzky B, Swanson R, Leonard RJ. Functional role of the β subunit of high-conductance calcium-activated potassium channels. *Neuron* 1995; 14:645-50; PMID:7695911; [http://dx.doi.org/10.1016/0896-6273\(95\)90321-6](http://dx.doi.org/10.1016/0896-6273(95)90321-6)
58. Gribkoff VK, Lum-Ragan JT, Boissard CG, Post-Munson DJ, Meanwell NA, Starrett JE Jr., Kozlowski ES, Romine JL, Trojnecki JT, McKay MC, et al. Effects of channel modulators on cloned large-conductance calcium-activated potassium channels. *Mol Pharmacol* 1996; 50:206-17; PMID:8700114
59. Sanchez M, McManus OB. Paxilline inhibition of the alpha-subunit of the high-conductance calcium-activated potassium channel. *Neuropharmacology* 1996; 35:963-8; PMID:8938726; [http://dx.doi.org/10.1016/0028-3908\(96\)00137-2](http://dx.doi.org/10.1016/0028-3908(96)00137-2)
60. Strøbæk D, Christophersen P, Holm NR, Moldt P, Ahning PK, Johansen TE, Olesen SP. Modulation of the Ca^{2+} -dependent K^{+} channel, *hSlo*, by the substituted diphenylurea NS 1608, paxilline and internal Ca^{2+} . *Neuropharmacology* 1996; 35:903-14; PMID:8938721; [http://dx.doi.org/10.1016/0028-3908\(96\)00096-2](http://dx.doi.org/10.1016/0028-3908(96)00096-2)
61. Koschak A, Koch RO, Liu J, Kaczorowski GJ, Reinhart PH, Garcia ML, Knaus HG. [^{125}I] Iberitoxin-D19Y/Y36F, the first selective, high specific activity radioligand for high-conductance calcium-activated potassium channels. *Biochemistry* 1997; 36:1943-52; PMID:9048582; <http://dx.doi.org/10.1021/bi962074m>
62. Meera P, Wallner M, Toro L. A neuronal β subunit (KCNMB4) makes the large conductance, voltage- and Ca^{2+} -activated K^{+} channel resistant to charyb-dotoxin and iberitoxin. *Proc Natl Acad Sci U S A* 2000; 97:5562-7; PMID:10792058; <http://dx.doi.org/10.1073/pnas.100118597>
63. Bentzen BH, Nardi A, Calloe K, Madsen LS, Olesen SP, Grunnet M. The small molecule NS11021 is a potent and specific activator of Ca^{2+} -activated big-conductance K^{+} channels. *Mol Pharmacol* 2007; 72:1033-44; PMID:17636045; <http://dx.doi.org/10.1124/mol.107.038331>
64. Magleby KL. Gating mechanism of BK (Slo1) channels: so near, yet so far. *J Gen Physiol* 2003; 121:81-96; PMID:12566537; <http://dx.doi.org/10.1085/jgp.20028721>
65. Tian L, Duncan RR, Hammond MS, Coghill LS, Wen H, Rusinova R, Clark AG, Levitan IB, Shipston MJ. Alternative splicing switches potassium channel sensitivity to protein phosphorylation. *J Biol Chem* 2001; 276:7717-20; PMID:11244090; <http://dx.doi.org/10.1074/jbc.C000741200>
66. Sørensen MV, Sausbier M, Ruth P, Seidler U, Riederer B, Praetorius HA, Leipziger J. Adrenaline-induced colonic K^{+} secretion is mediated by $K_{Ca}1.1$ (BK) channels. *J Physiol* 2010; 588:1763-77; PMID:20351045; <http://dx.doi.org/10.1113/jphysiol.2009.181933>
67. Wang Q, Curran ME, Splawski I, Burn TC, Millholland JM, VanRaay TJ, Shen J, Timothy KW, Vincent GM, de Jager T, et al. Positional cloning of a novel potassium channel gene: *KVLQT1* mutations cause cardiac arrhythmias. *Nat Genet* 1996; 12:17-23; PMID:8528244; <http://dx.doi.org/10.1038/ng0196-17>
68. Schroeder BC, Waldegger S, Fehr S, Bleich M, Warth R, Greger R, Jentsch TJ. A constitutively open potassium channel formed by KCNQ1 and KCNE3. *Nature* 2000; 403:196-9; PMID:10646604; <http://dx.doi.org/10.1038/35003200>
69. Warth R, Garcia Alzamora M, Kim JK, Zdebek A, Nitschke R, Bleich M, Gerlach U, Barhanin J, Kim SJ. The role of KCNQ1/KCNE1 K^{+} channels in intestine and pancreas: lessons from the KCNE1 knockout mouse. *Pflügers Arch* 2002; 443:822-8; PMID:11889581; <http://dx.doi.org/10.1007/s00424-001-0751-3>
70. Heitzmann D, Grahmmer F, von Hahn T, Schmitt-Gräff A, Romeo E, Nitschke R, Gerlach U, Lang HJ, Verrey F, Barhanin J, et al. Heteromeric KCNE2/KCNQ1 potassium channels in the luminal membrane of gastric parietal cells. *J Physiol* 2004; 561:547-57; PMID:15579540; <http://dx.doi.org/10.1113/jphysiol.2004.075168>
71. Vallon V, Grahmmer F, Volkl H, Sandu CD, Richter K, Rexhepaj R, Gerlach U, Rong Q, Pfeifer K, Lang F. KCNQ1-dependent transport in renal and gastrointestinal epithelia. *Proc Natl Acad Sci U S A* 2005; 102:17864-9; PMID:16314573; <http://dx.doi.org/10.1073/pnas.0505860102>
72. Kim SJ, Greger R. Voltage-dependent, slowly activating K^{+} current (I_{Ks}) and its augmentation by carbachol in rat pancreatic acini. *Pflügers Arch* 1999; 438:604-11; PMID:10555556; <http://dx.doi.org/10.1007/s004240051083>
73. Köttgen M, Hofer A, Kim SJ, Beschoner U, Schreiber R, Hug MJ, Greger R. Carbachol activates a K^{+} channel of very small conductance in the basolateral membrane of rat pancreatic acinar cells. *Pflügers Arch* 1999; 438:597-603; PMID:10555555; <http://dx.doi.org/10.1007/s004240051082>

74. Dedek K, Waldegger S. Colocalization of KCNQ1/KCNE channel subunits in the mouse gastrointestinal tract. *Pflügers Arch* 2001; 442:896-902; PMID:11680623; <http://dx.doi.org/10.1007/s004240100609>
75. Grahmmer F, Herling AW, Lang HJ, Schmitt-Gräff A, Wittekindt OH, Nitschke R, Bleich M, Barhanin J, Warth R. The cardiac K⁺ channel KCNQ1 is essential for gastric acid secretion. *Gastroenterology* 2001; 120:1363-71; PMID:11313306; <http://dx.doi.org/10.1053/gast.2001.24053>
76. Grunnet M, Jespersen T, MacAulay N, Jørgensen NK, Schmitt N, Pongs O, Olesen SP, Klaerke DA. KCNQ1 channels sense small changes in cell volume. *J Physiol* 2003; 549:419-27; PMID:12702742; <http://dx.doi.org/10.1111/jphysiol.2003.038455>
77. Hammami S, Willumsen NJ, Meinild AK, Klaerke DA, Novak I. Purinergic signalling – a possible mechanism for KCNQ1 channel response to cell volume challenges. *Acta Physiol (Oxf)* 2013; 207:503-15; PMID:22805606; <http://dx.doi.org/10.1111/j.1748-1716.2012.02460.x>
78. Barhanin J, Lesage F, Guillemare E, Fink M, Lazdunski M, Romey GK. K_vLQT1 and IsK (minK) proteins associate to form the I_{Ks} cardiac potassium current. *Nature* 1996; 384:78-80; PMID:8900282; <http://dx.doi.org/10.1038/384078a0>
79. Sanguinetti MC, Curran ME, Zou A, Shen J, Spector PS, Atkinson DL, Keating MT. Coassembly of K_vLQT1 and minK (IsK) proteins to form cardiac I_{Ks} potassium channel. *Nature* 1996; 384:80-3; PMID:8900283; <http://dx.doi.org/10.1038/384080a0>
80. Sesti F, Goldstein SA. Single-channel characteristics of wild-type I_{Ks} channels and channels formed with two minK mutants that cause long QT syndrome. *J Gen Physiol* 1998; 112:651-63; PMID:9834138; <http://dx.doi.org/10.1085/jgp.112.6.651>
81. Yang Y, Sigworth FJ. Single-channel properties of I_{Ks} potassium channels. *J Gen Physiol* 1998; 112:665-78; PMID:9834139; <http://dx.doi.org/10.1085/jgp.112.6.665>
82. Lerche C, Seeböhm G, Wagner CI, Scherer CR, Dehmelt L, Aitbol I, Gerlach U, Brendel J, Attali B, Busch AE. Molecular impact of MinK on the enantiospecific block of I_{Ks} by chromanol. *Br J Pharmacol* 2000; 131:1503-6; PMID:11139424; <http://dx.doi.org/10.1038/sj.bjp.0703734>
83. Unsöld B, Kerst G, Brouss H, Hübner M, Schreiber R, Nitschke R, Greger R, Bleich M. KCNE1 reverses the response of the human K⁺ channel KCNQ1 to cytosolic pH changes and alters its pharmacology and sensitivity to temperature. *Pflügers Arch* 2000; 441:368-78; PMID:11211125; <http://dx.doi.org/10.1007/s004240000434>
84. Takumi T, Ohkubo H, Nakanishi S. Cloning of a membrane protein that induces a slow voltage-gated potassium current. *Science* 1988; 242:1042-5; PMID:3194754; <http://dx.doi.org/10.1126/science.3194754>
85. Tinel N, Diochot S, Lauritzen I, Barhanin J, Lazdunski M, Borsotto M. M-type KCNQ2-KCNQ3 potassium channels are modulated by the KCNE2 subunit. *FEBS Lett* 2000; 480:137-41; PMID:11034315; [http://dx.doi.org/10.1016/S0014-5793\(00\)01918-9](http://dx.doi.org/10.1016/S0014-5793(00)01918-9)
86. Busch AE, Busch GL, Ford E, Suessbrich H, Lang HJ, Greger R, Kunzelmann K, Attali B, Stühmer W. The role of the I_{Ks} protein in the specific pharmacological properties of the I_{Ks} channel complex. *Br J Pharmacol* 1997; 122:187-9; PMID:9313924; <http://dx.doi.org/10.1038/sj.bjp.0701434>
87. Loussouarn G, Charpentier F, Mohammad-Panah R, Kunzelmann K, Baró I, Escande D. KvLQT1 potassium channel but not IsK is the molecular target for *trans*-6-cyano-4-(*N*-ethylsulfonyl-*N*-methylamino)-3-hydroxy-2,2-dimethyl – chromane. *Mol Pharmacol* 1997; 52:1131-6; PMID:9396783
88. Wang HS, Brown BS, McKinnon D, Cohen IS. Molecular basis for differential sensitivity of KCNQ and I_{Ks} channels to the cognitive enhancer XE991. *Mol Pharmacol* 2000; 57:1218-23; PMID:10825393
89. Kang J, Chen XL, Wang L, Rampe D. Interactions of the antimalarial drug mefloquine with the human cardiac potassium channels KvLQT1/minK and HERG. *J Pharmacol Exp Ther* 2001; 299:290-6; PMID:11561091
90. Salata JJ, Jurkiewicz NK, Wang J, Evans BE, Orme HT, Sanguinetti MC. A novel benzodiazepine that activates cardiac slow delayed rectifier K⁺ currents. *Mol Pharmacol* 1998; 54:220-30; PMID:9658209
91. Yang WP, Levesque PC, Little WA, Conder ML, Shalaby FY, Blamir MA. KvLQT1, a voltage-gated potassium channel responsible for human cardiac arrhythmias. *Proc Natl Acad Sci U S A* 1997; 94:4017-21; PMID:9108097; <http://dx.doi.org/10.1073/pnas.94.8.4017>
92. Poter F, Scott JD, Mohammad-Panah R, Escande D, Baró I. AKAP proteins anchor cAMP-dependent protein kinase to KvLQT1/IsK channel complex. *Am J Physiol Heart Circ Physiol* 2001; 280:H2038-45; PMID:11299204
93. Loussouarn G, Demolombe S, Mohammad-Panah R, Escande D, Baró I. Expression of CFTR controls cAMP-dependent activation of epithelial K⁺ currents. *Am J Physiol* 1996; 271:C1565-73; PMID:8944640
94. Huang P, Trotter K, Boucher RC, Milgram SL, Stutts MJ. PKA holoenzyme is functionally coupled to CFTR by AKAPs. *Am J Physiol Cell Physiol* 2000; 278:C417-22; PMID:10666038
95. Warmke JW, Ganetzky B. A family of potassium channel genes related to *eag* in *Drosophila* and mammals. *Proc Natl Acad Sci U S A* 1994; 91:3438-42; PMID:8159766; <http://dx.doi.org/10.1073/pnas.91.8.3438>
96. Lastraioli E, Guasti L, Crociani O, Polvani S, Hofmann G, Witche H, Bencini L, Calistri M, Messerini L, Scatizzi M, et al. *herg1* gene and HERG1 protein are overexpressed in colorectal cancers and regulate cell invasion of tumor cells. *Cancer Res* 2004; 64:606-11; PMID:14744775; <http://dx.doi.org/10.1158/0008-5472.CAN-03-2360>
97. Saganich MJ, Vega-Saenz de Miera E, Nadal MS, Baker H, Coetzee WA, Rudy B. Cloning of components of a novel subthreshold-activating K⁺ channel with a unique pattern of expression in the cerebral cortex. *J Neurosci* 1999; 19:10789-802; PMID:10594062
98. Ju M, Wray D. Molecular identification and characterization of the human eag2 potassium channel. *FEBS Lett* 2002; 524:204-10; PMID:12135768; [http://dx.doi.org/10.1016/S0014-5793\(02\)03055-7](http://dx.doi.org/10.1016/S0014-5793(02)03055-7)
99. Huang X, Dubuc AM, Hashizume R, Berg J, He Y, Wang J, Chiang C, Cooper MK, Northcott PA, Taylor MD, et al. Voltage-gated potassium channel EAG2 controls mitotic entry and tumor growth in medulloblastoma via regulating cell volume dynamics. *Genes Dev* 2012; 26:1780-96; PMID:22855790; <http://dx.doi.org/10.1101/gad.193789.112>
100. Gómez-Varela D, Zwick-Wallasch E, Knötgen H, Sánchez A, Hettmann T, Ossipov D, Weseloh R, Contreras-Jurado C, Rothe M, Stühmer W, et al. Monoclonal antibody blockade of the human Eag1 potassium channel function exerts antitumor activity. *Cancer Res* 2007; 67:7343-9; PMID:17671204; <http://dx.doi.org/10.1158/0008-5472.CAN-07-0107>
101. Pardo LA, Gómez-Varela D, Major F, Sansuk K, Leurs R, Downie BR, Tietze LF, Stühmer W. Approaches targeting K_v10.1 open a novel window for cancer diagnosis and therapy. *Curr Med Chem* 2012; 19:675-82; PMID:22204340; <http://dx.doi.org/10.2174/092986712798992011>
102. Kiehn J, Lacerda AE, Wible B, Brown AM. Molecular physiology and pharmacology of *HERG*. Single-channel currents and block by dofetilide. *Circulation* 1996; 94:2572-9; PMID:8921803; <http://dx.doi.org/10.1161/01.CIR.94.10.2572>
103. McDonald TV, Yu Z, Ming Z, Palma E, Meyers MB, Wang KW, Goldstein SA, Fishman GI. A minK-HERG complex regulates the cardiac potassium current I_{Kr}. *Nature* 1997; 388:289-92; PMID:9230439; <http://dx.doi.org/10.1038/40882>
104. Abbott GW, Sesti F, Splawski I, Buck ME, Lehmann MH, Timothy KW, Keating MT, Goldstein SA. MiRP1 forms I_{Kr} potassium channels with HERG and is associated with cardiac arrhythmia. *Cell* 1999; 97:175-87; PMID:10219239; [http://dx.doi.org/10.1016/S0092-8674\(00\)80728-X](http://dx.doi.org/10.1016/S0092-8674(00)80728-X)
105. Trudeau MC, Warmke JW, Ganetzky B, Robertson GA. HERG, a human inward rectifier in the voltage-gated potassium channel family. *Science* 1995; 269:92-5; PMID:7604285; <http://dx.doi.org/10.1126/science.7604285>
106. Korolkova YV, Kozlov SA, Lipkin AV, Pluzhnikov KA, Hadley JK, Filippov AK, Brown DA, Angelo K, Strøbek D, Jespersen T, et al. An ERG channel inhibitor from the scorpion *uthus eupeus*. *J Biol Chem* 2001; 276:9868-76; PMID:11136720; <http://dx.doi.org/10.1074/jbc.M005973200>
107. Restano-Cassulini R, Korolkova YV, Diochot S, Gurrula G, Guasti L, Porselli L, Lazdunski M, Grishin EV, Arcangeli A, Wanke E. Species diversity and peptide toxins blocking selectivity of *ether-a-go-go*-related gene subfamily K⁺ channels in the central nervous system. *Mol Pharmacol* 2006; 69:1673-83; PMID:16497878; <http://dx.doi.org/10.1124/mol.105.019729>
108. Gerlach AC, Stoehr SJ, Castle NA. Pharmacological removal of human *ether-a-go-go*-related gene potassium channel inactivation by 3-nitro-*N*-(4-phenoxyphenyl) benzamide (ICA-105574). *Mol Pharmacol* 2010; 77:58-68; PMID:19805508; <http://dx.doi.org/10.1124/mol.109.059543>
109. Abi-Gerges N, Holkham H, Jones EM, Pollard CE, Valentin JP, Robertson GA. hERG subunit composition determines differential drug sensitivity. *Br J Pharmacol* 2011; 164:419-32; PMID:21449979; <http://dx.doi.org/10.1111/j.1476-5381.2011.01378.x>
110. Qu Y, Fang M, Gao B, Chui RW, Vargas HM, BeKm-1, a peptide inhibitor of human *ether-a-go-go*-related gene potassium currents, prolongs QTc intervals in isolated rabbit heart. *J Pharmacol Exp Ther* 2011; 337:2-8; PMID:21205913; <http://dx.doi.org/10.1124/jpet.110.176883>
111. Gessner G, Heinemann SH. Inhibition of hEAG1 and hERG1 potassium channels by clofilium and its tertiary analogue LY97241. *Br J Pharmacol* 2003; 138:161-71; PMID:12522086; <http://dx.doi.org/10.1038/sj.bjp.0705025>
112. Suessbrich H, Schönherr R, Heinemann SH, Lang F, Busch AE. Specific block of cloned *Herg* channels by clofilium and its tertiary analog LY97241. *FEBS Lett* 1997; 414:435-8; PMID:9315735; [http://dx.doi.org/10.1016/S0014-5793\(97\)01030-2](http://dx.doi.org/10.1016/S0014-5793(97)01030-2)
113. Gessner G, Zacharias M, Bechstedt S, Schönherr R, Heinemann SH. Molecular determinants for high-affinity block of human EAG potassium channels by antiarrhythmic agents. *Mol Pharmacol* 2004; 65:1120-9; PMID:15102940; <http://dx.doi.org/10.1124/mol.65.5.1120>
114. Zeng H, Lozinskaya IM, Lin Z, Willette RN, Brooks DP, Xu X. Mallotoxin is a novel human *ether-a-go-go*-related gene (hERG) potassium channel activator. *J Pharmacol Exp Ther* 2006; 319:957-62; PMID:16928897; <http://dx.doi.org/10.1124/jpet.106.110593>
115. Perry M, Sachse FB, Abbruzzese J, Sanguinetti MC. PD-118057 contacts the pore helix of hERG1 channels to attenuate inactivation and enhance K⁺ conductance. *Proc Natl Acad Sci U S A* 2009; 106:20075-80; PMID:19892732
116. Sanguinetti MC, Jiang C, Curran ME, Keating MT. A mechanistic link between an inherited and an acquired cardiac arrhythmia: *HERG* encodes the I_{Kr} potassium channel. *Cell* 1995; 81:299-307; PMID:7736582; [http://dx.doi.org/10.1016/0092-8674\(95\)90340-2](http://dx.doi.org/10.1016/0092-8674(95)90340-2)

117. Kagan A, Melman YF, Krumerman A, McDonald TV. 14-3-3 amplifies and prolongs adrenergic stimulation of HERG K⁺ channel activity. *EMBO J* 2002; 21:1889-98; PMID:11953308; <http://dx.doi.org/10.1093/emboj/21.8.1889>
118. Li Y, Sroubek J, Krishnan Y, McDonald TV. A-kinase anchoring protein targeting of protein kinase A and regulation of HERG channels. *J Membr Biol* 2008; 223:107-16; PMID:18679741; <http://dx.doi.org/10.1007/s00232-008-9118-4>
119. Kiehn J, Karle C, Thomas D, Yao X, Brachmann J, Kübler W. HERG potassium channel activation is shifted by phorbol esters via protein kinase A-dependent pathways. *J Biol Chem* 1998; 273:25285-91; PMID:9737994; <http://dx.doi.org/10.1074/jbc.273.39.25285>
120. Thomas D, Zhang W, Karle CA, Kathöfer S, Schöls W, Kübler W, Kiehn J. Deletion of protein kinase A phosphorylation sites in the HERG potassium channel inhibits activation shift by protein kinase A. *J Biol Chem* 1999; 274:27457-62; PMID:10488078; <http://dx.doi.org/10.1074/jbc.274.39.27457>
121. Joiner WJ, Tang MD, Wang LY, Dworetzky SI, Boissard CG, Gan L, Gribkoff VK, Kaczmarek LK. Formation of intermediate-conductance calcium-activated potassium channels by interaction of Slack and Slo subunits. *Nat Neurosci* 1998; 1:462-9; PMID:10196543; <http://dx.doi.org/10.1038/2176>
122. Bhattacharjee A, Joiner WJ, Wu M, Yang Y, Sigworth FJ, Kaczmarek LK. Slick (Slo2.1), a rapidly-gating sodium-activated potassium channel inhibited by ATP. *J Neurosci* 2003; 23:11681-91; PMID:14684870
123. Yuan A, Santi CM, Wei A, Wang ZW, Pollak K, Nonet M, Kaczmarek L, Crowder CM, Salkoff L. The sodium-activated potassium channel is encoded by a member of the *Slo* gene family. *Neuron* 2003; 37:765-73; PMID:12628167; [http://dx.doi.org/10.1016/S0896-6273\(03\)00096-5](http://dx.doi.org/10.1016/S0896-6273(03)00096-5)
124. Paulais M, Lachheb S, Teulon J. A Na⁺ – and Cl[–] – activated K⁺ channel in the thick ascending limb of mouse kidney. *J Gen Physiol* 2006; 127:205-15; PMID:16446508; <http://dx.doi.org/10.1085/jgp.200509360>
125. Yang B, Gribkoff VK, Pan J, Damagnez V, Dworetzky SI, Boissard CG, Bhattacharjee A, Yan Y, Sigworth FJ, Kaczmarek LK. Pharmacological activation and inhibition of *Slack* (*Slo2.2*) channels. *Neuropharmacology* 2006; 51:896-906; PMID:16876206; <http://dx.doi.org/10.1016/j.neuropharm.2006.06.003>
126. Biton B, Sethuramanujam S, Picchione KE, Bhattacharjee A, Khessibi N, Chesney F, Lanneau C, Curet O, Avenet P. The antipsychotic drug loxapine is an opener of the sodium-activated potassium channel slack (*Slo2.2*). *J Pharmacol Exp Ther* 2012; 340:706-15; PMID:22171093; <http://dx.doi.org/10.1124/jpet.111.184622>
127. Garg P, Sanguinetti MC. Structure-activity relationship of fenamates as Slo2.1 channel activators. *Mol Pharmacol* 2012; 82:795-802; PMID:22851714; <http://dx.doi.org/10.1124/mol.112.079194>
128. Berg AP, Sen N, Bayliss DA. TrpC3/C7 and Slo2.1 are molecular targets for metabotropic glutamate receptor signaling in rat striatal cholinergic interneurons. *J Neurosci* 2007; 27:8845-56; PMID:17699666; <http://dx.doi.org/10.1523/JNEUROSCI.0551-07.2007>
129. Dai L, Garg V, Sanguinetti MC. Activation of Slo2.1 channels by niflumic acid. *J Gen Physiol* 2010; 135:275-95; PMID:20176855; <http://dx.doi.org/10.1085/jgp.200910316>
130. Santi CM, Ferreira G, Yang B, Gazula VR, Butler A, Wei A, Kaczmarek LK, Salkoff L. Opposite regulation of Slick and Slack K⁺ channels by neuromodulators. *J Neurosci* 2006; 26:5059-68; PMID:16687497; <http://dx.doi.org/10.1523/JNEUROSCI.3372-05.2006>
131. Lesage F, Barhanin J. Molecular physiology of pH-sensitive background K_{2p} channels. *Physiology* (Bethesda) 2011; 26:424-37; PMID:22170960; <http://dx.doi.org/10.1152/physiol.00029.2011>
132. Duprat F, Girard C, Jarretou G, Lazdunski M. Pancreatic two P domain K⁺ channels TALK-1 and TALK-2 are activated by nitric oxide and reactive oxygen species. *J Physiol* 2005; 562:235-44; PMID:15513946; <http://dx.doi.org/10.1113/jphysiol.2004.071266>
133. Reyes R, Duprat F, Lesage F, Fink M, Salinas M, Farman N, Lazdunski M. Cloning and expression of a novel pH-sensitive two pore domain K⁺ channel from human kidney. *J Biol Chem* 1998; 273:30863-9; PMID:9812978; <http://dx.doi.org/10.1074/jbc.273.47.30863>
134. Medhurst AD, Rennie G, Chapman CG, Meadows H, Duckworth MD, Kelsell RE, Gloger II, Pangalos MN. Distribution analysis of human two pore domain potassium channels in tissues of the central nervous system and periphery. *Brain Res Mol Brain Res* 2001; 86:101-14; PMID:11165377; [http://dx.doi.org/10.1016/S0169-328X\(00\)00263-1](http://dx.doi.org/10.1016/S0169-328X(00)00263-1)
135. Warth R, Barrière H, Meneton P, Bloch M, Thomas J, Tauc M, Heitzmann D, Romeo E, Verrey F, Mengual R, et al. Proximal renal tubular acidosis in TASK2 K⁺ channel-deficient mice reveals a mechanism for stabilizing bicarbonate transport. *Proc Natl Acad Sci U S A* 2004; 101:8215-20; PMID:15141089; <http://dx.doi.org/10.1073/pnas.0400081101>
136. Cotten JF, Zou HL, Liu C, Au JD, Yost CS. Identification of native rat cerebellar granule cell currents due to background K channel KCNK5 (TASK-2). *Brain Res Mol Brain Res* 2004; 128:112-20; PMID:15363886; <http://dx.doi.org/10.1016/j.molbrainres.2004.06.007>
137. La JH, Kang D, Park JY, Hong SG, Han J. A novel acid-sensitive K⁺ channel in rat dorsal root ganglia neurons. *Neurosci Lett* 2006; 406:244-9; PMID:16904821; <http://dx.doi.org/10.1016/j.neulet.2006.07.039>
138. Niemeyer MI, Cid LP, Barros LF, Sepúlveda FV. Modulation of the two-pore domain acid-sensitive K⁺ channel TASK-2 (KCNK5) by changes in cell volume. *J Biol Chem* 2001; 276:43166-74; PMID:11560934; <http://dx.doi.org/10.1074/jbc.M107192200>
139. Kindler CH, Paul M, Zou H, Liu C, Winegar BD, Gray AT, Yost CS. Amide local anesthetics potently inhibit the human tandem pore domain background K⁺ channel TASK-2 (KCNK5). *J Pharmacol Exp Ther* 2003; 306:84-92; PMID:12660311; <http://dx.doi.org/10.1124/jpet.103.049809>
140. Gray AT, Zhao BB, Kindler CH, Winegar BD, Mazurek MJ, Xu J, Chavez RA, Forsayeth JR, Yost CS. Volatile anesthetics activate the human tandem pore domain baseline K⁺ channel KCNK5. *Anesthesiology* 2000; 92:1722-30; PMID:10839924; <http://dx.doi.org/10.1097/0000542-200006000-00032>
141. Morton MJ, Abohamed A, Sivaprasadarao A, Hunter M. pH sensing in the two-pore domain K⁺ channel, TASK2. *Proc Natl Acad Sci U S A* 2005; 102:16102-6; PMID:16239344; <http://dx.doi.org/10.1073/pnas.0506870102>
142. Hayoz S, Bychkov R, Serir K, Docquier M, Bény JL. Purinergic activation of a leak potassium current in freshly dissociated myocytes from mouse thoracic aorta. *Acta Physiol (Oxf)* 2009; 195:247-58; PMID:18616685; <http://dx.doi.org/10.1111/j.1748-1716.2008.01884.x>
143. Nguyen TD, Meichle S, Kim US, Wong T, Moody MW. P2Y₁₁, a purinergic receptor acting via cAMP, mediates secretion by pancreatic duct epithelial cells. *Am J Physiol Gastrointest Liver Physiol* 2001; 280:G795-804; PMID:11292586
144. Pedersen SF, Hoffmann EK, Novak I. Cell volume regulation in epithelial physiology and cancer. *Front Physiol* 2013; 4:233;
145. Prevarskaya N, Skryma R, Shuba Y. Ion channels and the hallmarks of cancer. *Trends Mol Med* 2010; 16:107-21; PMID:20167536; <http://dx.doi.org/10.1016/j.molmed.2010.01.005>
146. Brevet M, Fucks D, Chatelain D, Regimbeau JM, Delcenserie R, Sevestre H, Ouadid-Ahidouch H. Deregulation of 2 potassium channels in pancreas adenocarcinomas: implication of K_v1.3 gene promoter methylation. *Pancreas* 2009; 38:649-54; PMID:19465885; <http://dx.doi.org/10.1097/MPA.0b013e3181a56ebf>
147. Bielanska J, Hernández-Losa J, Pérez-Verdaguer M, Moline T, Somoza R, Ramón Y Cajal S, Condom E, Ferreres JC, Felipe A. Voltage-dependent potassium channels Kv1.3 and Kv1.5 in human cancer. *Curr Cancer Drug Targets* 2009; 9:904-14; PMID:20025600; <http://dx.doi.org/10.2174/156800909790192400>
148. Parks SK, Chiche J, Pouyssegur J. pH control mechanisms of tumor survival and growth. *J Cell Physiol* 2011; 226:299-308; PMID:20857482; <http://dx.doi.org/10.1002/jcp.22400>
149. Webb BA, Chimenti M, Jacobson MP, Barber DL. Dysregulated pH: a perfect storm for cancer progression. *Nat Rev Cancer* 2011; 11:671-7; PMID:21833026; <http://dx.doi.org/10.1038/nrc3110>
150. Wilschanski M, Novak I. The cystic fibrosis of exocrine pancreas. In: Riordan JR, Boucher RC, Quinton PM, eds. *Cystic Fibrosis: A Trilogy of Biochemistry, Physiology and Pathology*. Cold Spring Harb Perspect Med 2013; 3(5):a009746; PMID:23637307; doi:10.1101/cshperspect.a009746.