

Molecular Virology

Josephine Wu, DDS, CLSp(MB), CLDir, Mona Sharaan, MD,
and David Y. Zhang, MD, PhD, MPH

CONTENTS

I. General	21-3	V. Cytomegalovirus (CMV)	21-20
Limitation and Pitfalls	21-3	General Characteristics	21-20
Specimen Types	21-3	Clinical Presentation	21-20
Assay Performance Analysis	21-3	Diagnostic Methods	21-20
II. Human Immunodeficiency		Specimens	21-20
Virus (HIV).....	21-4	Conventional Tests.....	21-20
General Characteristics	21-4	Molecular Methods	21-21
Clinical Presentation	21-4	Clinical Utility	21-22
Diagnostic Methods	21-5	Laboratory Methods for Anti-viral	
Specimens	21-5	Susceptibility Testing	
Conventional Tests and Problems	21-5	of CMV Isolates	21-22
Molecular Methods	21-7	VI. Epstein-Barr Virus (EBV)	21-25
Clinical Utility	21-11	General Characteristics	21-25
III. Hepatitis C Virus (HCV).....	21-11	Clinical Presentation	21-25
General Characteristics	21-11	Diagnostic Methods	21-26
Clinical Presentation	21-11	Specimens	21-26
Diagnostic Methods	21-13	Conventional Tests.....	21-26
Specimens	21-13	Molecular Methods	21-27
Conventional Tests and Problems	21-13	Sensitivity and Specificity	21-28
Molecular Methods	21-13	Pitfalls	21-28
Pitfalls	21-15	Clinical Utility	21-28
Clinical Utility	21-15	VII. Herpes Simplex Virus	
IV. Hepatitis B Virus (HBV)	21-16	(HSV)	21-28
General Characteristics	21-16	General Characteristics	21-28
Clinical Presentation	21-16	Clinical Presentation	21-28
Diagnostic Methods	21-17	Diagnostic Methods	21-29
Specimens	21-17	Specimens	21-29
Conventional Tests and Problems	21-17	Conventional Tests and Problems	21-29
Molecular Methods	21-18	Molecular Methods	21-29
Pitfalls	21-19	Sensitivity and Specificity	21-30
Clinical Utility	21-19	Pitfalls	21-30
		Clinical Utility	21-30

VIII. Varicella Zoster (VZV).....21-31	Pitfalls21-42
General Characteristics21-31	Clinical Utility21-42
Clinical Presentation21-31	
Diagnostic Methods21-31	XIII. Respiratory Syncytial Virus (RSV)21-42
Specimens (Molecular Tests)21-31	General Characteristics21-42
Conventional Tests and Problems21-31	Clinical Presentation21-42
Molecular Methods21-32	Diagnostic Methods21-43
Pitfalls21-32	Specimens21-43
Clinical Utility21-32	Conventional Tests and Problems21-43
	Molecular Methods21-43
IX. Human Papilloma Virus (HPV).....21-32	Sensitivity and Specificity21-43
General Characteristics21-32	Pitfalls21-43
Clinical Presentation21-33	Clinical Utility21-43
Diagnostic Methods21-34	
Specimens21-34	XIV. Severe Acute Respiratory
Conventional Tests and Problems21-34	Syndrome (SARS)21-43
Molecular Methods21-34	General Characteristics21-43
Pitfalls21-37	Clinical Presentation21-44
Clinical Utility21-37	Diagnostic Methods21-44
	Specimens21-44
X. Influenza A, B, and C.....21-37	Conventional Tests
General Characteristics21-37	and Problems21-44
Clinical Presentation21-38	Molecular Methods21-44
Diagnostic Methods21-38	Sensitivity and Specificity21-44
Specimens21-38	Pitfalls21-44
Conventional Tests and	Clinical Utility21-44
Problems21-38	
Molecular Methods21-38	XV. Enterovirus.....21-45
Sensitivity and Specificity21-38	General Characteristics21-45
Pitfalls21-39	Clinical Presentation21-45
Clinical Utility21-39	Diagnostic Methods21-45
	Specimens21-45
XI. Avian Influenza (Bird) Influenza	Conventional Tests and Problems21-45
(Flu) A Viruses21-39	Molecular Methods21-45
General Characteristics21-39	Sensitivity and Specificity21-46
Clinical Presentation21-40	Pitfalls21-46
Diagnostic Methods21-40	Clinical Utility21-46
Culture21-40	
Serologic Test21-40	XVI. JC/BK Virus21-46
Molecular Test21-40	General Characteristics21-46
Limitation21-40	Clinical Presentation21-46
	Diagnostic Methods21-46
XII. Adenovirus.....21-40	Specimens21-46
General Characteristics21-40	Conventional Tests and Problems21-46
Clinical Presentation21-40	Molecular Methods21-47
Diagnostic Methods21-42	Sensitivity and Specificity21-47
Specimens (Molecular Test)21-42	Pitfalls21-47
Conventional Tests and Problems21-42	Clinical Utility21-47
Molecular Methods21-42	
	XVII. Suggested Reading21-47

GENERAL

Limitation and Pitfalls

- ◆ Traditional viral isolation by cell culture assays and conventional serological methods have been previously used to detect and identify various virus infections
- ◆ More recently, however, molecular methods, i.e., hybridization and amplification techniques, have been developed that more accurately and rapidly detect viral organisms with improved sensitivity and specificity. Also, these advanced techniques provide laboratories with decreased hands-on time and shorter time to results
- ◆ However, the routine implementation of nucleic acid (both DNA and RNA) amplification and hybridization methodologies is associated with limitations, particularly in the clinical laboratory. These limitations and pitfalls include, but are not limited to:
 - Increased cost/test due to expensive instrumentation and reagents
 - Amplification carryover contamination
 - Standardization of positive and negative assay controls
 - Integrated co-amplified internal DNA control to demonstrate absence of polymerase (PCR) inhibitors and amplification
 - Prevention of false-positive and false-negative reports due to antigenic and pathogen nucleic acid sequence drift and accurate interpretation of data and software analyses

Specimen Types

- ◆ Specimens: collection of adequate specimen material is important for molecular diagnosis of viruses
- Whole blood: 3–5 mL collected in an ethylenediamine tetra acetic acid (EDTA) (lavender top) tube. Store at 4–25°C. Do not freeze
- Plasma: Collect 7–10 mL of whole blood in EDTA, acid citrate dextrose (ACD) solution A, or plasma preparation tubes (PPT) (Becton Dickinson, Franklin Lakes, NJ) sterile tube. Store whole blood at room temperature (18–30°C) for no >4 hours. Remove plasma from cells within 4 hours of collection by centrifugation at 1000g for 10–15 minutes. Do not clarify by filtration or further centrifugation. Store plasma at –60 to –80°C within 30 minutes of separation. Plasma may also be stored at –20°C in non-frost-free freezer for up to 72 hours if colder freezer is not available. Ship on dry ice for overnight delivery. The minimum volume of specimen is 2 mL of plasma
- Urine: first 10–20 mL of void urine collected in a sterile urinalysis container (15-mL sterile screw-cap tube preferred). Store at 4–25°C for <24 hours or store at –70°C for long term

- Bronchial lavage/tracheal aspirate: 1–4 mL, collected in a sterile tube. Store at 4–25°C
- Bone marrow: 1–2 mL, collected in EDTA tube. Store at 4–25°C. Do not freeze
- Tissue: approximately 0.5 cm tissue block collected in a sterile screw-top container, add small amount of saline to keep it moist. Avoid the use of viral transport media to avoid potential inhibition of PCR. Fresh tissues should be stored at –72°C immediately to preserve the nucleic acids. Paraffin-embedded tissue is acceptable. Usually 5–10 sections (5 µm thickness) are sufficient for PCR analysis. The tissue sections must be deparaffinized with xylene before DNA extraction
- Fecal: sterile swab (plastic shaft only) or very small fecal sample placed in 1–2 mL sterile saline in a container with tight fitting lid. Do not use viral transport media to avoid potential inhibition of PCR
- Swab: sterile swab (plastic shaft only) placed in 1–2 mL sterile saline. Do not use viral transport media to avoid potential inhibition of PCR
- Cerebrospinal fluid (CSF): 1–1.5 mL fluid, frozen. Submitted in a sterile, leak-proof tube

Assay Performance Analysis

- ◆ Analytical performance
 - Analytical sensitivity: to determine the lowest number of targets that can be detected by the assay
 - Cross-reactivity (specificity): to determine if the assay can produce false-positive results in the presence of high concentration of other similar or unrelated pathogens (bacteria, yeast, and virus)
 - Linearity: to evaluate the log differences from the expected concentration; this difference should be within ± 0.1 log (or a ratio of observed mean quantitation to expected concentration within 95%)
 - Quantitative range: the measured concentrations within the linear range with a good reproducibility
- ◆ Clinical performance
 - Limit of detection (LOD): the lowest concentration of target nucleic acids that can be detected (at or above the detection cutoff) in 95% of replicates (usually 10 replicates)
 - Detection cutoff: the point on the assay quantitation scale such that 95% of negative specimens produce results below this cutoff with 95% confidence
 - Reproducibility: the reproducibility of the test is usually established by testing three to six sample panels with known concentrations of target in triplicate or quadruplicate. A commercial panel should be used to establish this parameter, if available. Reproducibility is expressed as percent

- coefficient of variation (CV). For quantitative assays, the CVs range from 10 to 50%
- Precision: the reproducibility of a test result (e.g., inter- and intra-technologist and inter- and intra-assay)
- Sensitivity: true-positive samples, percentage of true-positive samples above the LOD
- Specificity: true-negative samples, percentage of true-negative samples below the LOD

HUMAN IMMUNODEFICIENCY VIRUS (HIV)

General Characteristics

- ◆ HIV is a RNA retrovirus belonging to the lentivirus family. HIV-1 and HIV-2 are genetically different, but related forms of HIV. HIV-1 is commonly associated with acquired immunodeficiency syndrome (AIDS) in the United States, Europe, and Central Africa; HIV-2 is associated with AIDS in West Africa
- ◆ Structure of HIV virion (**Figures 1 and 2**)
 - HIV virus consists of a spherical viral particle encased in a lipid bilayer derived from host cell covered by protruding peg-like structures composed of gp41 and gp120 glycoproteins
 - The virus core nucleocapsid contains the major capsid protein, p24; two copies of genomic RNA, and three viral enzymes (protease, reverse transcriptase [RT], and integrase)
- ◆ Viral replication
 - Entry into the host cell requires binding of the gp120 molecule on the virus to CD4 molecules on the host cell's surface
 - Two surface molecules CCR5 and CXCR4, chemokine receptors for β -chemokines and α -chemokines are also required for entry
 - Once bound, the viral envelope fuses with the cell membrane and the virus's RNA and enzymes enter the cytoplasm
 - RT allows the single-stranded RNA of the virus to be copied and double-stranded DNA (dsDNA) to be generated
 - Integrase then facilitates the integration of viral DNA into the cellular chromosome when the cell divides and provides latency enabling the virus to effectively evade host responses
 - Viral proteins are facilitated by protease and assembled into viral particles using the host cell's protein-making machinery
 - An HIV-infected cell does not necessarily lyse the cell during replication; in fact many viral particles can bud out of the cell and the cycle begins again
- ◆ The *gag*, *pol*, and *env* genes encode for structural proteins for new virus particles. The other six genes *tat*, *rev*, *nef*, *vif*, *vpr*, and *vpu* regulate the synthesis and assembly of viral particles
- ◆ The phylogenetic analysis of the nucleotide sequences of the *env* gene has enabled classification of HIV-1 into three groups: M (Major), N (non-M), and O (outlier). The group M of HIV-1 infection has been classified into nine different genetic subtypes A–K. Presently, group M of HIV-1 globally causes 99.6% of all human infections. Subtype/clade B is the most prevalent in the developed world
- ◆ HIV is transmitted via sexual contact, blood (via transfusion, blood products, or contaminated needles), or passage from mother to child (*in utero*, during birth, or ingestion of breast milk). Although saliva can contain small quantities of the virus, the virus cannot be spread by kissing. HIV is not spread by the fecal-oral route, aerosols, insects, or casual contact

Clinical Presentation

- ◆ HIV is the causative agent of AIDS, the leading cause of death in humans between the ages of 25–44 years
- ◆ Two main targets of HIV: immune system and central nervous system (CNS). HIV targets CD4+ T cells, monocytes/macrophages, and Langerhans cells/dendritic cells causing severe immunosuppression and neuropathologic symptoms such as dementia, meningitis, and encephalopathy in the host
- ◆ Common opportunistic infections: *Pneumocystis carinii*, candidiasis, tuberculosis, cryptococcus, and cytomegalovirus retinitis
- ◆ Common malignancies: Kaposi sarcoma, lymphoma (non-Hodgkin's and brain primary), and uterine carcinoma
- ◆ Natural history includes three phases:
 - Early, acute phase
 - Middle, chronic phase
 - Crisis phase
 - Acute phase develops 3–6 weeks after initial exposure with self-limited flu-like symptoms resolving 2–4 weeks later in 50–60% of patients. Characterized by high level of viral production, viremia, and widespread seeding of lymphoid tissues
 - Chronic phase is associated with a period of latency in which the immune system is intact, but there is continuous HIV replication that may last for years. Patients are either asymptomatic or develop persistent lymphadenopathy with minor opportunistic infections, such as candidiasis or herpes zoster

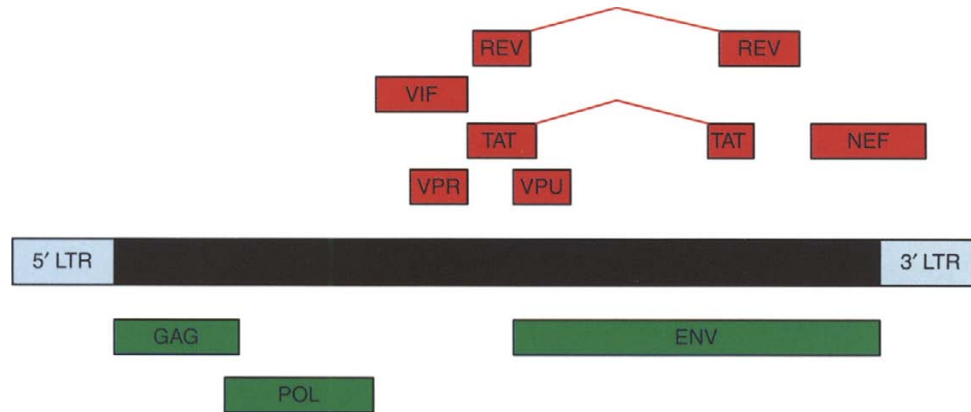

Fig. 1. Schematic illustration of HIV genome structure.

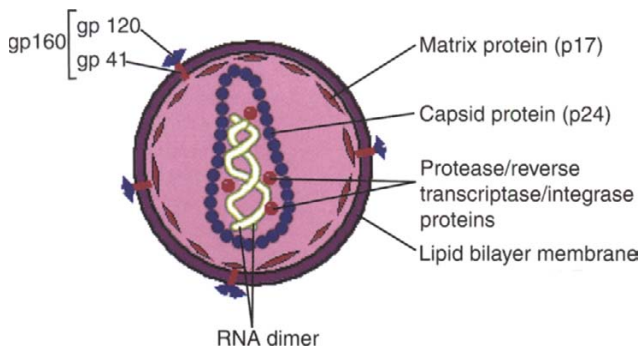

Fig. 2. HIV viral particle (www.mclid.co.uk/hiv).

Diagnostic Methods

Specimens

- ◆ Whole blood, serum, and plasma (**Table 1**)

Conventional Tests and Problems

- ◆ Lymphocyte count
 - Quantitation of CD4 cells was the first effective predictor of HIV progression
 - Still used for persons infected with HIV-2 or HIV-1 variants not accurately quantitated using viral load assays
 - The CD4 cell count (<200 cells/mm³) is important in determining the staging of HIV disease and for indicating the need for prophylaxis against opportunistic pathogens
 - Measurement and trending of CD4 percentage in addition to absolute count must be performed prior to initiation or adjustment of anti-retroviral (ARV) treatment management decisions
 - CD4 percentage may widely vary due to concurrent medical conditions, CD4 subsets, and inter-laboratory variation to name a few
- ◆ Viral culture
 - Although very specific, single-positive culture must be confirmed with a second specimen

- Rarely used due to high cost, labor-intensive, and less sensitivity than antibody testing
- Negative culture may be caused by technical problems, a defective virus, or the inability of the virus to replicate in culture

◆ Serological studies

- P24 antigen
 - Early developed assay to detect HIV infection and screen donated blood for HIV
 - Advantage is to detect HIV infection prior to development of antibodies
 - Disadvantage is limited utility due to the short window of time and should only be used when other tests are unavailable
- Antibody screening assays (qualitative)
 - Detection of antibodies to HIV is the most common way to diagnose HIV infection in adults and children >18 months old
 - These antibodies are usually detectable within 3–6 weeks after infection
 - Most individuals seroconvert by 12 weeks, although may not be detectable for months or years
 - Serologic HIV antibody screening testing is highly sensitive (enzyme-linked immunosorbent assay [ELISA], rapid test, or home test), but requires follow-up of preliminary positive specimens with a highly specific HIV antibody confirmatory assay (Western blot) (**Figure 3**)
 - ELISA method most common and earliest developed antibody screening assay
 - Home Access HIV-1 test system analyzes a dried-blood spot from finger stick collected on filter paper at home and sent to a testing facility
 - Rapid tests for HIV are assays that detect antibodies to HIV within minutes

Table 1. Specimen Handling in Different HIV Assays

Assay	Collection	Transport	Storage	Comments
Antibody screening assay	Serum (including serum collected in serum separator tubes) or plasma containing heparin, EDTA, citrate, or CPDA-1 anticoagulants	–	For long-term storage, specimens should be stored frozen. Specimens can be stored at 2–8°C for a maximum of 14 days	Samples may be tested up to 3 freeze–thaw cycles
HIV monitoring assay	Plasma specimens anticoagulated with EDTA or ACD only. Specimens must <i>not</i> be anticoagulated with heparin	Whole blood should be stored at 2–25°C for no longer than 6 hours. Plasma must be separated within 6 hours of collection by centrifugation at 800–1600g for 20 minutes at room temperature and transferred to a polypropylene tube to prevent viral degradation	Plasma may be stored at 2–8°C for up to 5 days or frozen at –70°C.	Specimens should be stored in 600–700 µL aliquots in sterile, 2-mL polypropylene tubes. Freeze thaw studies have shown that specimens may be tested for up to three freeze–thaw cycles without loss of viral RNA
HIV Genotyping	Plasma specimens anticoagulated with EDTA. Specimens must not be anticoagulated with heparin	Whole blood should be stored at 2–25°C for not >2 hours. Plasma should be separated within 30 minutes, but not >120 minutes by centrifugation at 1000–2000g for 15 minutes at 15–25°C and transferred to a polypropylene tube	Plasma may be stored frozen at –65–80°C for up to 6 months	Samples may be tested up to two freeze–thaw cycles. Plasma specimens containing the following have been shown to interfere with results: lipids up to 30 mg/mL, bilirubin up to 0.6 mg/mL, hemoglobin up to 5 mg/mL

– Confirmatory antibody assays: WB

- Gold standard for HIV diagnostic testing
- The virus is disrupted, and the individual proteins are separated by molecular weight via differential migration on a polyacrylamide gel and blotted onto a membrane support. HIV serum antibodies from the patient are allowed to bind to the proteins in the membrane support, and patterns of reactivity can be visibly read
- Detects three major proteins/viral bands: p24 core protein and two envelope proteins, gp41 and gp120/160
- Reactive WB demonstrates antibody to two of the three major bands; non-reactive western blot (WB) will have no detectable viral bands (**Figure 4**)
- Repeated reactivity by ELISA and reactive by the confirmatory assay are reported as positive for antibody to HIV-1
- Non-reactive specimens by ELISA or repeatedly reactive by ELISA and non-reactive by the confirmatory assay are negative for antibody to HIV-1
- WB in which serum antibodies bind to any other combination of viral bands is considered indeterminate; follow-up blood specimen should be obtained 1 month later for repeat HIV antibody testing
- Individuals with repeat indeterminate results should undergo further testing using molecular assays, such as PCR

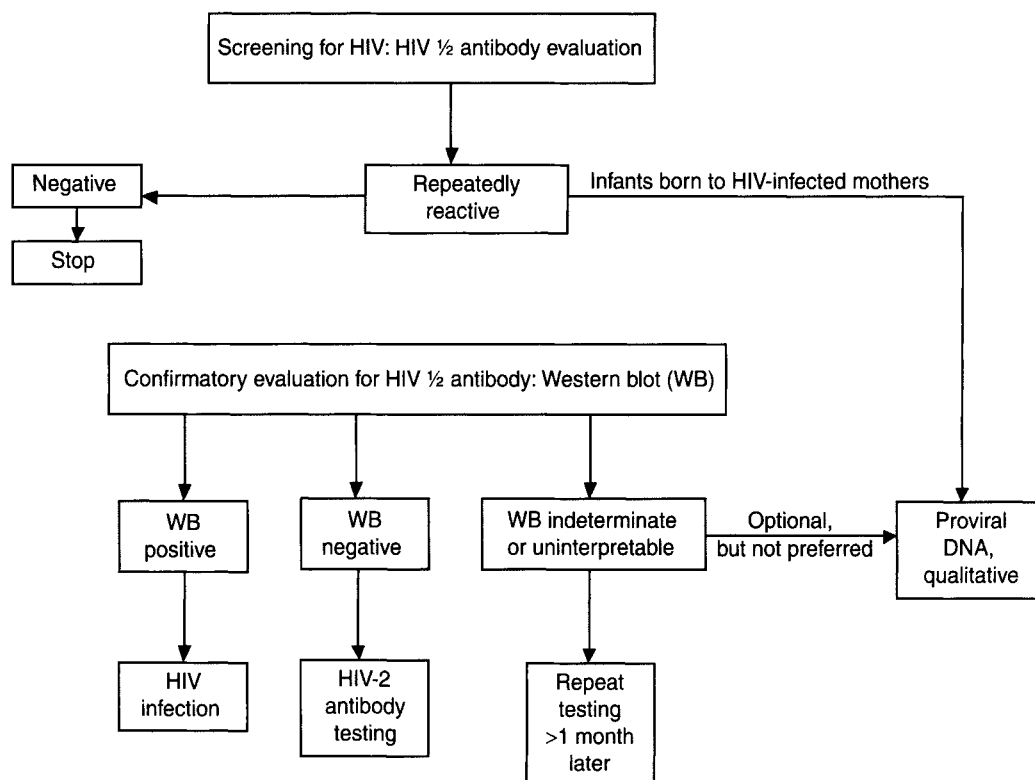

Fig. 3. HIV antibody screening algorithm.

- At least as sensitive as and more specific than screening assays, although they are not as sensitive in the detection of early seroconversion
- Disadvantages: more labor intensive, more prone to subjective interpretation, and more costly than screening assays
- Alternative antibody screening assay (qualitative)
- Food and Drug Administration (FDA) has approved assays that test body fluids other than blood to

detect HIV-1 antibodies, although sensitivity and specificity less reliable

- Utilize same testing algorithm as serum (ELISA followed by WB)
- Advantages are non-invasive sample collection, increased safety due to lack of needles, and disposal of infectious waste minimized
- Oral fluid (oral mucosal transudate)—antibodies detectable, but significantly lower (800–1000-fold) than those of serum
- Urine—interpretative criteria for a reactive WB requires only presence of visible band at gp160 region

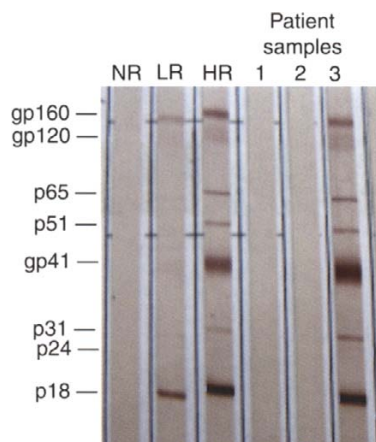

Fig. 4. WB analysis and band pattern interpretation. NR, negative control; LR, low reactive control; HR, high reactive control; 1–2, non-reactive; 3, reactive.

Molecular Methods

Qualitative Assay

- ◆ Viral identification assays—recommended for resolving indeterminate WB results
 - DNA PCR (Roche [Roche Diagnostics, Basel Switzerland])
 - Very sensitive methodology
 - Detection of HIV DNA in peripheral blood mononuclear cells by PCR is recommended for children <18 months old born to HIV-1-infected mothers
 - False-positive reactions common due to small amounts of background “noise” or contamination
 - All initial positive DNA PCR reactions must be confirmed with a second PCR test on a separate specimen

Table 2. Comparison of Commonly Used HIV Viral Load Assays

Characteristic	<i>Amplicor HIV-1 Monitor (Roche)</i>	<i>Branched-chain DNA (bDNA) (Versant)</i>	<i>NASBA (bioMérieux)</i>
Amplification method	Target amplification	Signal amplification	Target amplification
Specimen type	Plasma in ACD or EDTA tube	Plasma in EDTA tube	Plasma in ACD, EDTA, or heparin tube
Specimen volume	Standard 1.5: 0.2 mL ultrasensitive 1.5: 0.5 mL	1–2.0 mL	1 mL
Specimen transport	Prepare plasma within 6 hours of collection; store specimens at –20° or –70°C	Prepare plasma within 4 hours of collection; store specimens at –20°C or –70°C	Prepare plasma within 4 hours of collection; store specimen at –20°C or –70°C
Sensitivity (copies/mL)	Standard 1.5 (400) Ultrasensitive 1.5 (50)	Version 3.0 (75)	NucliSens QT (176)
Dynamic range (copies/mL)	Standard 1.5 (400–750,000) Ultrasensitive 1.5 (50–100,000)	Version 3.0 (75–500,000)	NucliSens QT (80–3,470,000)
Area of HIV genome selected for amplification	<i>Gag</i>	<i>Pol</i>	<i>Gag</i>

- Currently, recommended only for detection in infants born to mothers infected with HIV-1. However, potential for false-positive result must still be recognized
- Plasma HIV RNA
 - Surrogate marker of HIV disease progression
 - During acute infection, viral load levels are very high (ranging from 100,000 to >10 million copies/mL) and detectable before seroconversion
 - Important to use both a plasma HIV RNA assay and antibody/WB testing to establish diagnosis in acute and primary infections
 - Low levels of virus (<5000 copies/mL) may be indicative of a false-positive result and should not be considered diagnostic of primary HIV infection. Standard antibody testing should be repeated
- Calculation of HIV viremia based on optical density (OD) reading. Input quantitation standard (QS) copies is lot specific and provided with each kit. Standard sample volume factor = 40; ultrasensitive sample volume factor = 4. OD_{450} : OD at 450 nm; QS. The well with the lowest OD_{450} reading between 0.2 and 2 is selected for calculation (**Figures 6 and 7**)
- Branched DNA (bDNA) (Bayer HealthCare LLC, Berkeley, CA)
 - Quantitation of HIV-1 RNA in plasma using bDNA technology
 - bDNA is based on a series of hybridization procedure followed by an enzyme substrate reaction
 - HIV-1 present in patient blood is disrupted to release viral RNA
- Nucleic acid sequence-based assay (NASBA); NucliSens HIV-1 QT assay
 - Quantitation of HIV-1 RNA in plasma
 - HIV-1 is lysed, RNA extracted and bound to silica beads
 - Amplification occurs using specific primers derived from the gag region of the genome
 - The amplified RNA is hybridized to capture probes attached to magnetic beads, and the nucleic acid is detected by measuring electrochemiluminescence
 - Although only plasma is FDA approved, can use CSF, lymph tissue, genital secretions, and cells
 - Purified nucleic acid may be used for other molecular testing, such as sequencing

Quantitative

- ◆ Viral monitoring (**Table 2 and Figure 5**)
 - Amplicor™ HIV-1 Monitor and ultrasensitive (RT-PCR) (Roche [Roche Diagnostics, Basel Switzerland]) (FDA approved)
 - Quantitation of HIV-1 RNA in plasma
 - Standard assay LOD: >400 copies/mL and used for monitoring patient not on ARV therapy
 - Ultrasensitive assay: as low as 5–50 copies/mL and used for monitoring viral loads <400 copies/mL
 - Acute concurrent illness and/or recent vaccination may cause transient rise in viral load

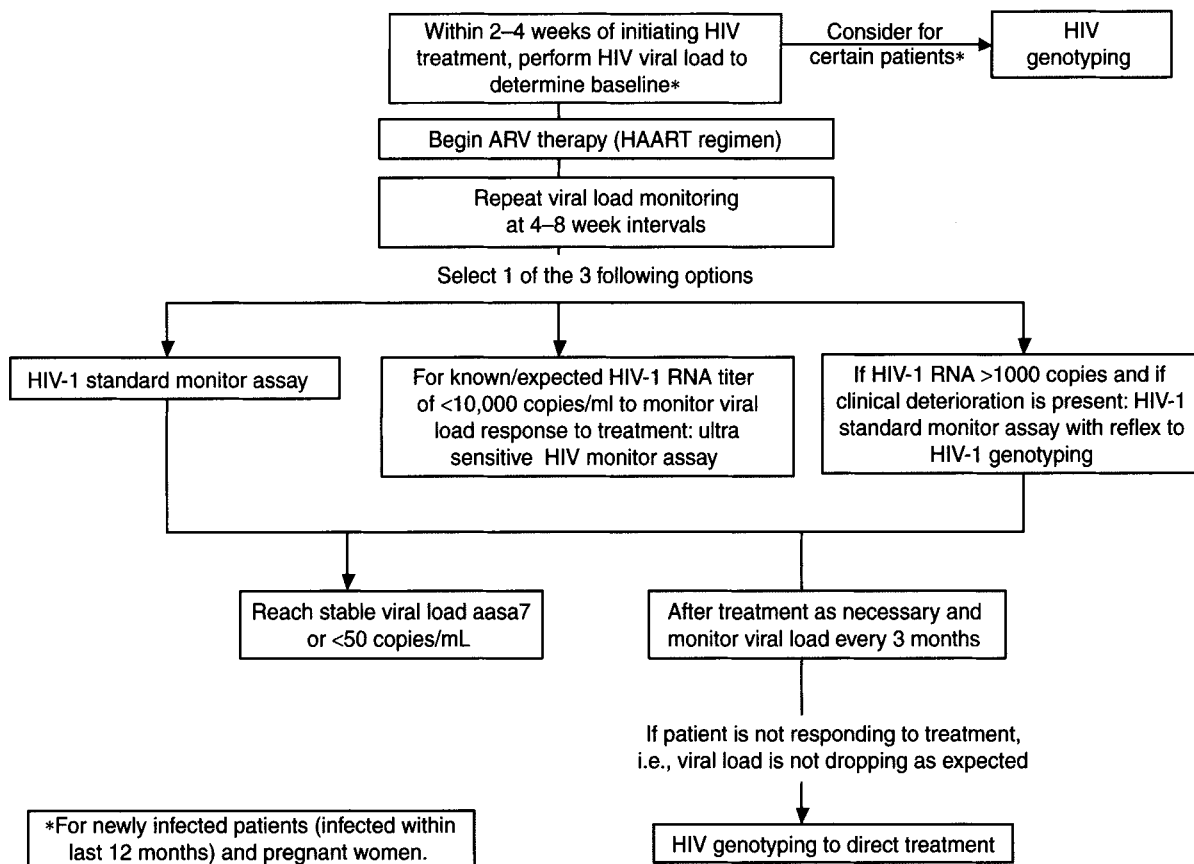

Fig. 5.HIV viral monitoring algorithm.

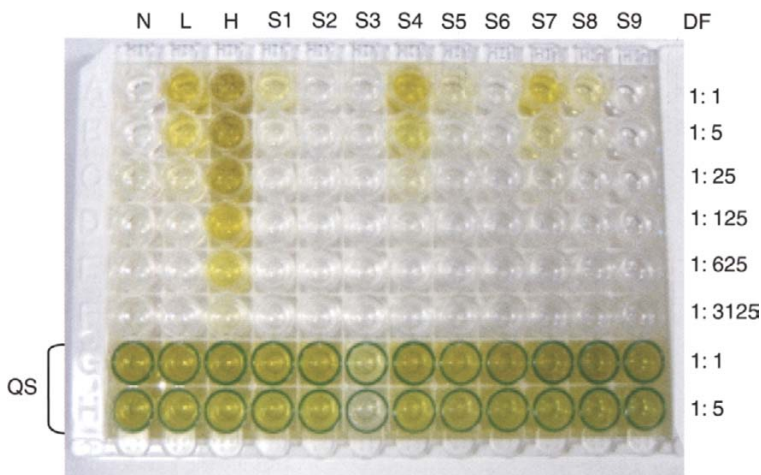

Fig. 6. HIV assay plate layout. N, negative; L, low positive control; H, high positive control; S1–S9, samples; DF, dilution factor; QS, quantitation standard.

Genotyping

◆ Genotypic-resistance testing uses RT-PCR and DNA sequencing techniques to identify the presence or absence of resistance-related mutations in the viral genome. The most common reverse transcriptase gene mutations occur at the following nucleotide position(s): 184 for 3TC; 74, 115 and 184 for Abacavir; 41, 67, 70, 210, 215, and 219 for AZT; 75 for d4T; 103 and 181 for Delavirdine; 103

and 188 for Efavirenz; 103, 181 and 188 for Nevirapine; and 65 and 70 for Adefovir. The most common protease gene mutations occur at the following nucleotide position(s): 50, 82, 84 and 101 for Amprenavir; 46, 82, 84 and 90 for Indinavir; 30 and 90 for Nelfinavir; 82 for Ritonavir and 48, 82 and 90 for Saquinavir”
 – Phenotypic testing—measures the ability of the HIV-1 virus to grow in different concentrations of

$$\left[\frac{\text{HIV OD}_{450} \times \text{DF}}{\text{QS OD}_{450} \times \text{DF}} \right] \times \text{Input QS copies} \times \text{sample volume factor} = \text{HIV-1 RNA copies/mL}$$

Calculation example: low positive control

$$\left[\frac{0.166 \times 25}{0.931 \times 5} \right] \times 51 \times 4 = \text{HIV-1 RNA copies/mL (ULTRA)} = 182 \text{ HIV RNA copies/mL}$$

	N	L	H	S1	S2	S3	S4	S5	S6	S7	S8	S9
A	0.015	2.808	–	0.288	0.009	0.011	2.301	0.156	0.013	1.343	0.257	0.017
B	0.010	0.703	–	0.055	0.008	0.009	0.530	0.031	0.006	0.239	0.043	0.008
C	0.085	0.166	–	0.022	0.010	0.013	0.117	0.011	0.008	0.056	0.014	0.011
D	0.060	0.046	2.076	0.015	0.013	0.009	0.031	0.008	0.007	0.018	0.008	0.012
E	0.044	0.018	0.726	0.012	0.011	0.031	0.008	0.004	0.004	0.005	0.005	0.006
F	0.046	0.013	0.120	0.009	0.010	0.009	0.003	0.003	0.002	0.004	0.003	0.003
G	2.833	2.729	–	2.628	2.700	0.313	2.618	2.183	2.775	2.579	2.865	2.228
H	1.003	0.931	0.972	0.850	0.795	0.112	0.864	0.581	1.130	0.892	1.116	0.593
HIV	UND	182	19,046	<50	UND	UND	125	<50	UND	55	<50	UND

Fig. 7. HIV viral load (ultrasensitive) calculation.

drug under artificial conditions in the laboratory.

Although phenotyping is a direct measure of resistance it is more complex than genotyping, and therefore slower and more costly to perform

- No consensus on genotyping vs phenotyping; however, it is anticipated that genotyping will be used more often because of its greater accessibility, lower cost, and faster turnaround time

◆ Mechanism of resistance

- HIV is a highly polymorphic G virus (quasi-species), which during replication converts RNA to DNA by the action of the viral RT enzyme
- The RT enzyme has very little proof reading (correction) capacity, and therefore errors are incorporated into the pro-viral DNA during replication. Over time these errors, at concise drug binding sites, can provide a selection advantage for the virus in the presence of ARV drugs
- The resistant virus predominates with a subsequent increase in viral load. However, the extent of such resistance and the implications for choice of therapy can be determined by reading the sequence of the genes encoding the protease and the RT enzymes

◆ Indications for drug-resistant testing

- Drug-naïve patients with acute or recent infection
- Therapy failure, including suboptimal treatment response, when treatment change is considered
- Pregnant HIV-1-infected women and pediatric patients with detectable viral load when treatment initiation or change is considered
- Genotype source patient when post-exposure prophylaxis is considered

◆ TruGene™ HIV-1 Genotyping and Open Gene DNA Sequencing System (Bayer HealthCare LLC)

- It is a two-step procedure, which first amplifies the protease and RT regions of the HIV-1 genome using RT-PCR
- The amplified DNA is then sequenced to yield to the nucleotide profile of the virus using a sequencing gel
- Once the sequence has been generated it is compared with the wild-type HIV-1 sequence and any differences that confer drug resistance are highlighted

◆ ViroSeq™ HIV-1 Genotyping System (Celera Diagnostics, Alameda, CA; (distributed by Abbott Laboratories, Abbott Park, IL)

- It is a two-step procedure, which first amplifies the protease and RT regions of the HIV-1 genome using RT-PCR and cycling sequencing
- The amplified DNA is then sequenced to yield to the nucleotide profile of the virus using a capillary electrophoresis
- The minimum input of viral RNA to the assay should be 1000 copies/mL when using 1 mL of plasma to be successful in genotyping

◆ Pitfalls of genotyping

- Genotypic variants comprising <20–30% of the sample may not be detected as genotyping results reflect the predominate subtype
- Interpretation of genotyping results is based on the HIV-1 clade B, the most prevalent clade in the developed world. However, other subtypes and recombinants of HIV-1 may be undetected
- Assessing HIV-1 resistance is complicated by the replication kinetics of resistant mutants. Resistant mutants are often less fit than wild-type virus and may become undetectable with selective drugs. Nevertheless, these mutants persist in the patient and when the selective drug pressure is reapplied the mutants replicate and a resistant population quickly predominates

Clinical Utility

- ◆ Plasma HIV RNA is a surrogate marker of HIV disease progression that is used to guide and monitor therapy and management
- ◆ ARV therapy should be implemented in patients with any of the following clinical findings: symptomatic HIV infection or AIDS-defining condition, CD4 count ≤ 350 cells/mm³ or viral load $\geq 100,000$ copies/mL (pregnant mothers: ≥ 1000 copies/mL)
- ◆ The initial highly active ARV therapy goal in the ARV therapy-naïve patient should be able to attain a viral load of <50 copies/mL and should include the rational sequencing of ARV agents to achieve the maximum possible viral replication suppression
- ◆ In ARV treatment-naïve patients or patients who are on a successful treatment regimen, monitoring of viral loads should be measured at baseline, every 2–4 weeks after initiation, and every 3–4 months once maximal suppression is attained, although patients with CD4 counts >500 cells/mm³ may require less frequent viral load monitoring
- ◆ Typically, in patients beginning therapy or in those changing therapy as a result of virologic failure, viral load should be measured 2–4 weeks after therapy initiation. A decrease by at least 1 log (10-fold) indicates effective therapy. Most patients reach the goal of <50 copies/mL within 6 months. An absent or incomplete response of the viral load to ARV therapy should raise concerns about poor patient adherence to therapy and/or viral resistance
- ◆ If significant increase (threefold increase or more) in viral load without clear explanation, viral load should be repeated to confirm virologic failure
- ◆ Genotypic-resistance testing should be performed prior to initiating treatment in ARV therapy-naïve patients and in patients with >1000 copies/mL, or non-responsive to ARV
- ◆ Genotypic-resistance testing is not recommended in patients with 500–1000 copies/mL or less and has discontinued ARV therapy for >1 year

HEPATITIS C VIRUS (HCV)

General Characteristics

- ◆ HCV is the major cause of non-A, non-B hepatitis (91%) affecting about 3% of the world's population
- ◆ The most common route of transmission is via blood and blood products, i.e., immunoglobulin, surgery, and intravenous drug abuse, which has significantly reduced with the advent of routine blood screenings. Sexual transmission as well as vertical transmission from mother to infant at a rate of 6%
- ◆ HCV is a positive-sense, single-stranded RNA virus that represents the third genus of the family *Flaviviridae*. The genome encodes for a single open reading frame coding structural (one core and two envelope) proteins as well as a series of non-structural proteins (**Figure 8**)
 - 5' Untranslated region (NTR): most constant, used for HCV RNA assays, genotyping
 - Core region: constant, used in some genotype assays, core protein assay, PCR-(restriction fragment length polymorphism [RFLP]), and recombinant immunoblot assay (RIBA) tests
 - Envelope region: hypervariable region, associated with high rate of mutation in quasi-species
 - NS2: codes for protease
 - NS3 region: codes for protease/helicase, RIBA tests target this region
 - NS4 region: c100p antigen used in anti-HCV, RIBA tests target this region
 - NS5a region: codes for interferon response element
 - NS5b region: codes for RNA polymerase, NS5 antigen used in anti-HCV, and RIBA tests target this region
- ◆ HCV consists of a heterogeneous group of genotypes based on the sequence homology of 5' NTR. Currently, there are six types and over 90 subtypes. Types 1, 2, and 3 distributed worldwide, with types 1a and 1b responsible for approximately 60% of infections. Type 4 occurs primarily in the Middle East; type 5 in South Africa, and type 6 in Hong Kong. In the United States, approximately 72% of people infected with hepatitis C have genotype 1, and most others are types 2 or 3 (genotypes 4, 5, and 6 are not common in the United States)
- ◆ There is little difference in the mode of transmission or natural history of infection among the different genotypes
- ◆ Cure rates with anti-viral therapy are notably higher with genotypes 2 and 3, and the duration of HCV therapy is shorter for these genotypes

Clinical Presentation

- ◆ Prior to the isolation of the virus in 1989, hepatic infection with Hepatitis C was previously known as non-A, non-B hepatitis
- ◆ In the United States, approximately 4 million have been exposed to the virus; 3 million are chronic carriers
 - Acute infection is usually asymptomatic. 25% of patients develop acute hepatitis with jaundice and abnormal liver function (**Figure 9**)
 - Chronic infection: 50–70% patients eventually develop chronic infection and/or chronic hepatitis
 - Patients are often asymptomatic or have non-specific symptoms such as fatigue, malaise, and abdominal discomfort

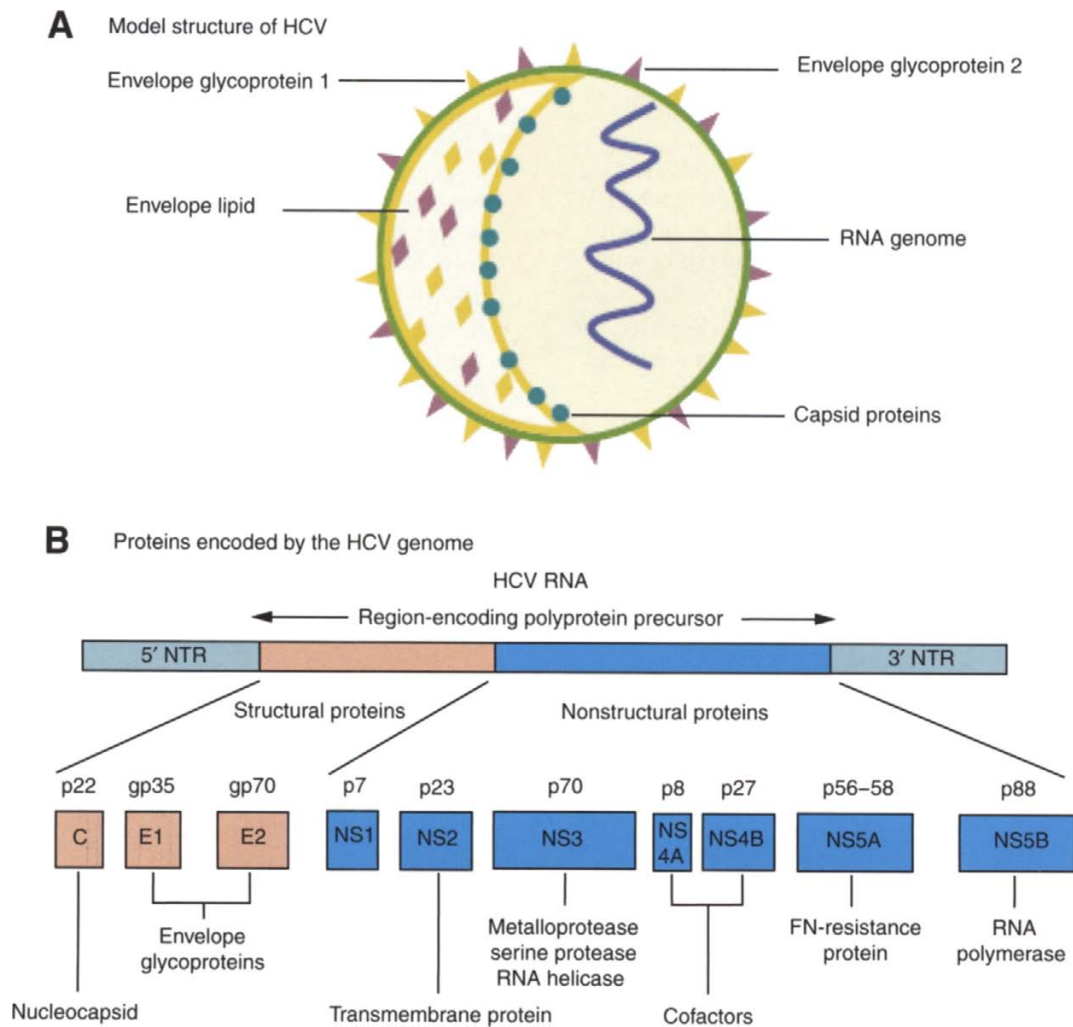

Fig. 8. HCV genome structure. (Adapted from Mónica Anzola and Juan José Burgos: Hepatocellular carcinoma: molecular interactions between hepatitis C virus and p53 in hepatocarcinogenesis, *Expert Rev Mol Med.* 2003;5.)

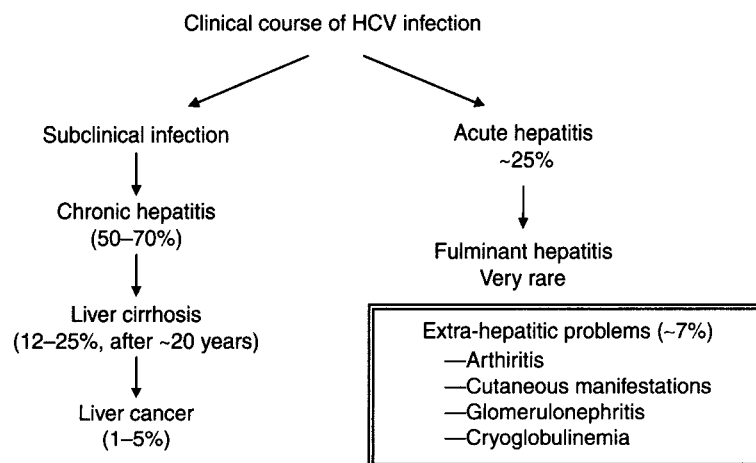

Fig. 9. Natural history of hepatitis C virus infection. (Adapted from National Institutes of Health Consensus Development Conference Statement: Management of hepatitis C: 2002-June 10-12, 2002. *Hepatology* 2002;36(Suppl 1): S3-20.)

- Mild-to-moderate elevations of alanine aminotransferase (ALT) (serum glutamic pyruvic transaminase [SGPT]) or aspartate aminotransferase (AST) (serum glutamic oxaloacetic transaminase [SGOT])
- Some asymptomatic patients have normal liver enzymes
 - As many as 44% have normal levels at initial evaluation
 - May have positive hepatitis C antibody test despite normal liver enzymes
- ◆ 20% patients eventually develop cirrhosis, which takes decades to occur. The severity of live cirrhosis does not correlate with liver enzymes and can only be evaluated by liver biopsy
- ◆ Small percentage of cirrhotic patients will develop hepatocellular carcinoma

Diagnostic Methods

Specimens

- ◆ Blood plasma or serum
 - Collection of samples in EDTA plasma
 - Rapid separation of serum or plasma from cells is recommended by centrifugation within 1 hour of collection
 - Unseparated EDTA plasma is stable at room temperature up to 24 hours after collection
 - Separated serum or plasma is stable at room temperature for up to 3 days, at refrigerator temperatures for up to 1 week, and frozen at -70°C for years

Conventional Tests and Problems

- ◆ Serological studies
 - Enzyme immunoassay (EIA)
 - The detection of HCV antibodies is recommended as the initial test for the identification of HCV and is useful for screening at risk populations
 - EIA is comparatively inexpensive, reproducible, and carries a high sensitivity (99%) and specificity (99%)
 - EIA can detect antibodies 4–10 weeks after infection
 - A negative EIA is usually sufficient to exclude the diagnosis of HCV infection in immunocompetent patients
 - However, the test can be falsely negative in those with immunodeficiencies or end stage renal disease
 - Once patients seroconvert, they usually remain positive for HCV antibody. Thus, the presence of HCV antibody may reflect remote or recent infection
 - A new “Total HCV core antigen ELISA” (Ortho Diagnostics) for detection and quantification of total core antigen in blood donors
 - It tests positive for anti-HCV antibodies and for prospective low-risk population screening
 - Total HCV core antigen ELISA (quantitative, Ortho Clinical Diagnostics) has sensitivity close to PCR assays in diagnosing acute HCV infections during the window period (before HCV antibodies develop)

- It is also used in monitoring response to anti-viral treatment
- RIBA
 - RIBA was used to confirm EIA results since the early generation. It had a high rate of false-positives
 - Third generation of RIBA was developed to test HCV (which includes NS5 protein) after earlier generations. It has high specificity

Molecular Methods

Qualitative (Table 3)

- ◆ Recommended sensitivity for testing is 50 IU/mL
- ◆ APTIMA[®] HCV RNA Qualitative Assay (Gen-Probe Inc., San Diego, CA)
 - Target amplification based on sequences of the 5' noncoding (NC) region of the HCV genome
 - Amplification of HCV RNA via transcription-mediated amplification method (TMA)
 - The LOD of TMA is 10 IU/mL
- ◆ Amplicor HCV test and Cobas[®] Amplicor HCV test, v2.0 (Roche)
 - Uses the primers KY78 and KY80 to amplify a 244-bp sequence of within the highly conserved 5' UTR of the HCV genome
 - LOD (200 μL): 25–50 IU/mL depending on genotypes (i.e., 1b = 25, 1a = 50)
 - Use of centrifugation or ultracolumn (Qiagen, Valencia, CA) to process a large volume (1 mL), the LOD can be further improved

Quantitative (Table 3)

- ◆ On average 1–2 \log_{10} units/mL less sensitive than qualitative test
- ◆ Used to establish baseline viral load (prior to therapy) and to monitor changes in viral load during therapy
- ◆ PCR—Amplicor HCV Monitor and its semi-automated Cobas Amplicor HCV Monitor Test, v2.0 (Roche)
 - Quantitative range of 600–500,000 IU/mL
- ◆ Real-time PCR—Roche TaqMan[™] Assay
 - Utilizes Fluorescence resonance energy transfer (FRET) technology and probes based on the detection of amplicon during temperature cycling
- ◆ Versant[®] HCV RNA 3.0, Quantiplex Assay (bDNA) (Bayer HealthCare LLC)
 - Signal amplification directed to the 5' NC region and core regions of the HCV genome
 - Microwell plate format
 - Equivalent detection of genotypes 1–6
 - LOD: 3200 HCV RNA copies/mL (5.2 HCV RNA copies/IU)
 - Broad dynamic range (615–7,690,000 IU/mL)
 - Comparative evaluations between Bayer's bDNA and Roche's PCR viral load assays demonstrated that PCR

Table 3. Characteristics of Current HCV RNA Assays

Assay	Manufacturer	Technique	Lower LOD (qualitative assay)	Dynamic range of quantification (quantitative assay)
Amplicor HCV v2.0	Roche Molecular Systems	Manual RT-PCR	50 IU/mL	NA
Cobas Amplicor HCV v2.0	Roche Molecular Systems	Semi-automated RT-PCR	50 IU/mL	NA
Versant HCV RNA Qualitative Assay	Bayer HealthCare	Manual TMA	10 IU/mL	NA
Amplicor HCV Monitor® v2.0	Roche Molecular Systems	Manual RT-PCR	600 IU/ml	600–500,000 IU/mL
Cobas Amplicor HCV Monitor v2.0	Roche Molecular Systems	Semi-automated RT-PCR	600 IU/mL	600–500,000 IU/mL
LCx HCV RNA Quantitative Assay	Abbott Diagnostic	Semi-automated RT-PCR	25 IU/mL	25–2,630,000 IU/mL
Versant HCV RNA 3.0 Assay	Bayer HealthCare	Semi-automated bDNA	615 IU/mL	615–7,700,000 IU/mL
Cobas TaqMan HCV Test	Roche Molecular Systems	Semi-automated real-time PCR	15 IU/mL	43–69,000,000 IU/mL
Abbott Real-Time	Abbott Diagnostic	Semi-automated real-time PCR	30 IU/mL or 12 IU/mL ^a	12–100,000,000 IU/mL

RT, reverse transcriptase; PCR, polymerase chain reaction; TMA, transcription-mediated amplification; bDNA, branched DNA; NA, not applicable

^aFor 0.2 or 0.5 mL of plasma analyzed, respectively

reported significantly lower viral loads (by as much as 1 log₁₀ lower) at the upper range

Genotyping

◆ TRUGENE® HCV 5' NC genotyping kit (Bayer HealthCare LLC)

- This technique utilizes PCR fragments previously generated by the diagnostic Roche Amplicor HCV test
- Simultaneous PCR amplification and direct sequencing (CLIP sequencing, a proprietary single tube reaction). Does not require definition given the proprietary nature of the 5' non-coding region (5' NCR)

◆ Versant HCV genotype assay (LiPA; Bayer HealthCare LLC)

- The INNO-LiPA HCV II method uses 19 type-specific oligonucleotide probes attached to nitrocellulose strips to detect sequence variations found in the 5' NC region of HCV
- The biotin-labeled PCR product is hybridized to the probes on the strip under stringent conditions.

After hybridization and washing, streptavidin-labeled alkaline phosphatase is added; followed by incubation with a chromogen, which results in the development of a purple-brown precipitate when there is a match between the probe and the biotinylated PCR product

- Hybridization of the amplicon with one or more lines on the strip allows the classification of six major genotypes and their most common subtypes

◆ Invader Assay (Third Wave Technologies, Madison, WI)—applies a new DNA-scanning method, termed cleavase fragment length polymorphism

- Relies on the formation of unique secondary structure that results when DNA is allowed to cool following brief heat denaturation and serve as substrates for structure-specific cleavase I enzyme, generating a set of cleavage products
- Formation of secondary structures is sensitive to nucleotide sequences

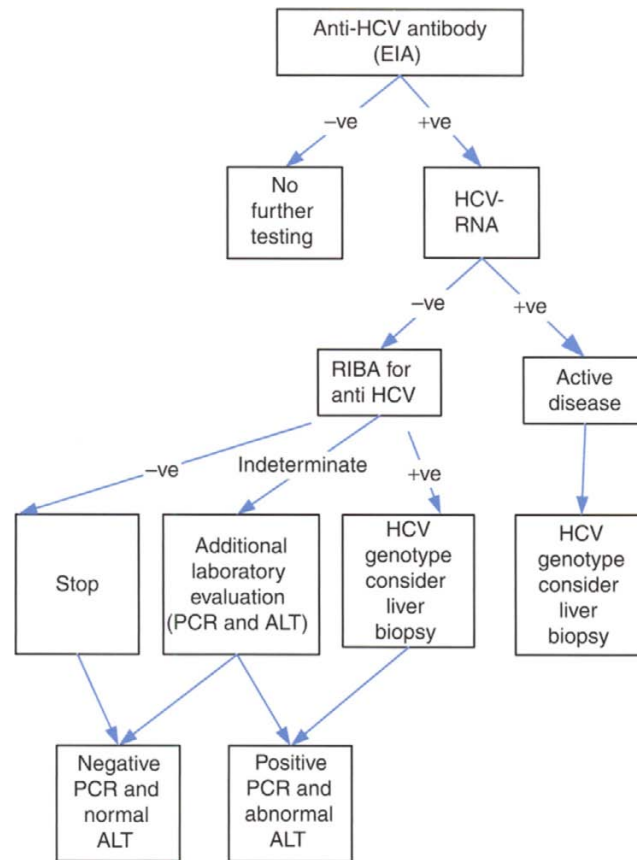

Fig. 10. Algorithm of HCV testing.

- The presence of sequence polymorphisms results in the generation of a unique collection of cleavage products or structural fingerprints
- It targets the well-conserved 5' non-coding region of HCV

Pitfalls

- ◆ It is important to note that a “genotype bias” is possible for all HCV molecular assays because of the extensive genetic heterogeneity of the virus
- ◆ False-positive results due to contamination (detected by negative control)
- ◆ False-negative results due to amplification inhibition (detected by internal control) or due to a loss of viral DNA during specimen preparation
- ◆ “Home-brew” or laboratory developed PCR assay are not standardized and variations in sample handling and laboratory methods can affect the sensitivity of the assay

Clinical Utility

- ◆ HCV tests should be used in high-risk patients, such as intravenous drug users, children born to HCV positive mothers, and HIV positive patients. **Figure 10** shows the algorithm of HCV testing
- ◆ Patients suspicious for chronic HCV infection should be tested for HCV antibodies
- ◆ HCV RNA testing should be performed in:
 - Patients with a positive anti-HCV test
 - Patients considered for anti-viral treatment and require quantitative monitoring
 - Patients with unexplained liver disease with a negative anti-HCV result and immunocompromised or suspicious for acute HCV infection
- ◆ HCV genotyping should be determined in HCV infected individuals prior to treatment to guide the duration of therapy and likelihood of response
- ◆ The treatment of choice is peginterferon plus ribavirin

HEPATITIS B VIRUS (HBV)

General Characteristics

- ◆ HBV is an enveloped dsDNA hepadnavirus. It is a 47-nm spherical virus with three important polypeptides: hepatitis B surface antigen (HBsAg) is an envelope protein, hepatitis B core antigen (HBcAg) is a core protein, and hepatitis B e antigen (HBeAg) is an early protein and a non-structural protein coded by core gene. The envelope protein is involved in viral binding and release into susceptible cells. The inner capsid relocates the DNA genome to the cell's nucleus where viral mRNAs are transcribed
- ◆ HBV is a circular, partially dsDNA virus of approximately 3200 nucleotides. This highly compact genome contains four open reading frames encoding the envelope (Pre-S1, Pre-S2, S), core (core, pre-core), polymerase, and X protein (Figure 11)
- ◆ Although hepatocytes are most susceptible to infection, other cell types may be affected to a lesser extent. The life cycle of HBV begins when it attaches to the cell surface. In the cytoplasm the DNA is still in the core but then capsid is removed and DNA passes into the nucleus, where it forms a covalently closed circular DNA (cccDNA)
- ◆ HBV uses the host transcription machinery to replicate its genes and uses RNA polymerase II of the host. The (-) strand of the cccDNA will act as the template for this transcription. After transcription the mRNAs are translated by the host's protein synthesis machinery to form viral proteins in the endoplasmic reticulum. The proteins are then assembled into virions that are secreted
- ◆ HBV is recognized as endemic in China and other parts of Asia. Over one-third of the world's population has been or is actively infected by HBV
- ◆ HBV strains are classified into seven genomic groups or genotypes, designated A–G, and based on the nucleotide homology of the surface gene. The predominant HBV genotypes cluster in geographical regions. Genotype A is mainly found in North-Western Europe, North America, and Africa, whereas genotypes B and C have been described in South-Eastern Asian populations. Genotype E and F are seen in East Africa, respectively. Genotype D is most often found in Southern Europe, parts of Central Asia, India, Africa, and the Middle East. Genotype G is a recently determined genotype in France, America, and Germany while genotype H has been reported in patients from Central America

Clinical Presentation (Figure 12)

- ◆ Transmitted parenterally and sexually by contaminating open cuts or mucous membranes and has a long incubation period (45–120 days)
- ◆ Majority of affected patients recover from the illness, characterized by:
 - Anorexia, nausea, vomiting, headache, fever, abdominal pain, dark urine, and sometimes jaundice

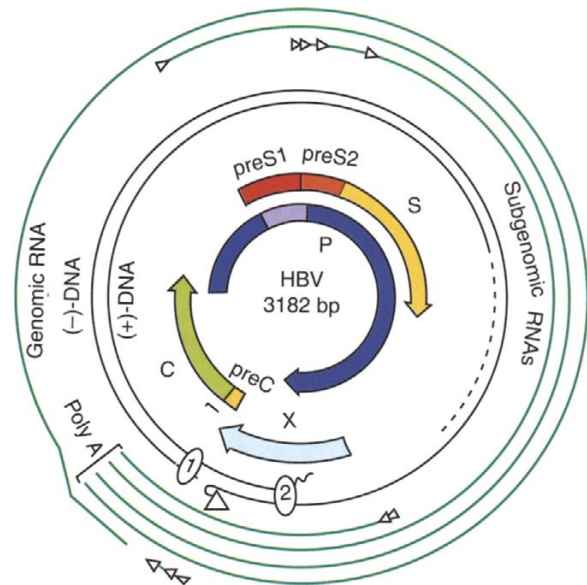

Fig. 11. HBV Genome. (Courtesy of Stephan Urban and Stefan Seitz, University of Heidelberg Dept. of Molecular Virology).

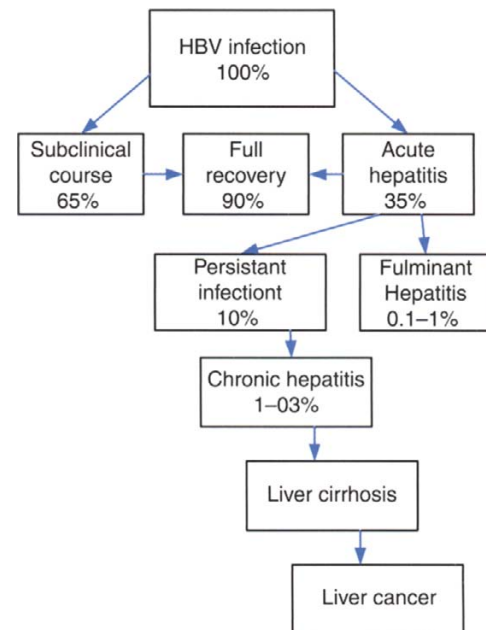

Fig. 12. Natural history of HBV.

- Elevated transaminases, hyperbilirubinemia, and elevated alkaline phosphatase may also occur
- Extrahepatic manifestations include arthralgias, arthritis, nephritis, and dermatitis
- ◆ 10% of patients continue to carry the virus or markers of the active viral infection >6 months after initial infection

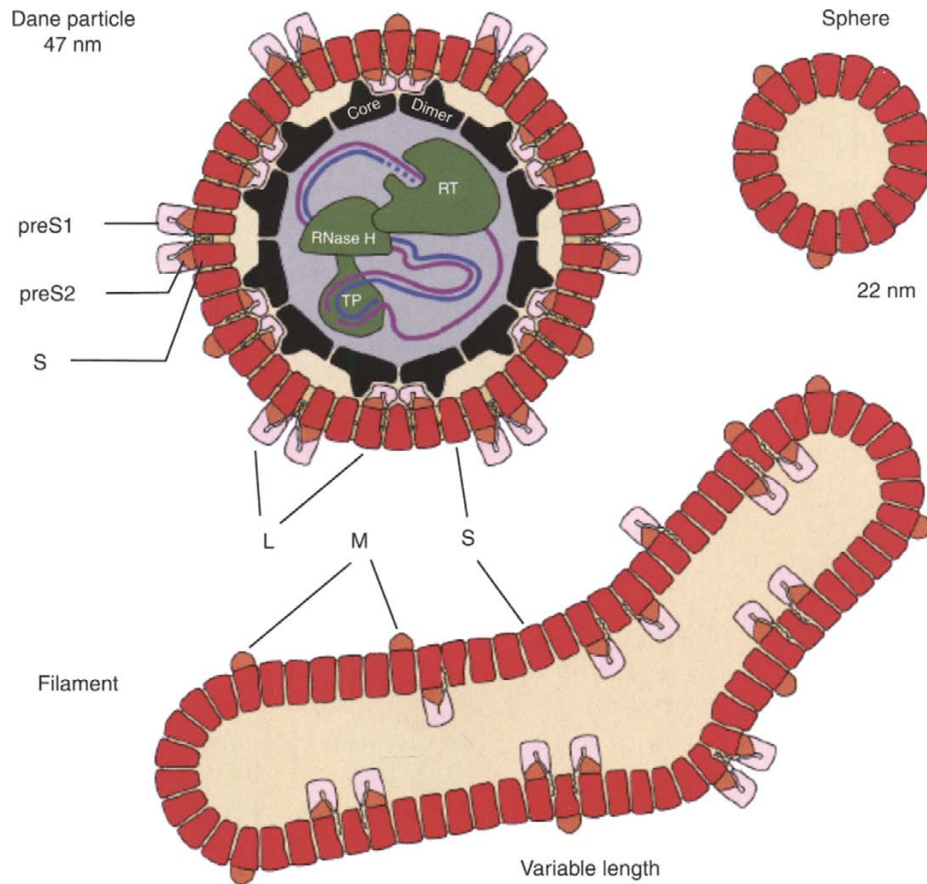

Fig. 13. HBV viral particle and antigens. (Courtesy of Stephan Urban and Stefan Seitz University of Heidelberg Dept. of Molecular Virology).

- Small percentage may develop chronic-persistent hepatitis with sequence fibrosis and cirrhosis
- Incidence of hepatocellular carcinoma is increased with the viral genome found integrated in the cellular DNA in 75% of cases
- May be associated with polyarteritis and cryoglobulinemia

Diagnostic Methods

Specimens

- ◆ Whole blood, serum, or plasma

Conventional Tests and Problems

- ◆ Serological studies

- Viral antigens and particles (**Figure 13**)

- Dane particle
 - dsDNA bilayered sphere
 - 42 nm diameter; 22 nm core
 - Rarely identified in infectious serum
 - Thought to be infectious virus particle

- HBsAg
 - Indicative of prior HBV exposure
 - Located on surface of Dane particle
 - Previously known as Australia antigen
- HBcAg
 - Represents acute or chronic infection
 - 28 nm core of the Dane particle
- HBeAg
 - Marker of HBV infection
 - Present in HBsAg-positive patients
 - Strong correlation with large serum concentrations of Dane particle and HbsAg
 - HBeAg is associated with high infectivity

- Antibodies (**Figure 14**)

- Anti-HBs
 - Antibody to surface antigen
 - Detected after disappearance of HbsAg
 - Protective properties
- Anti-HBc

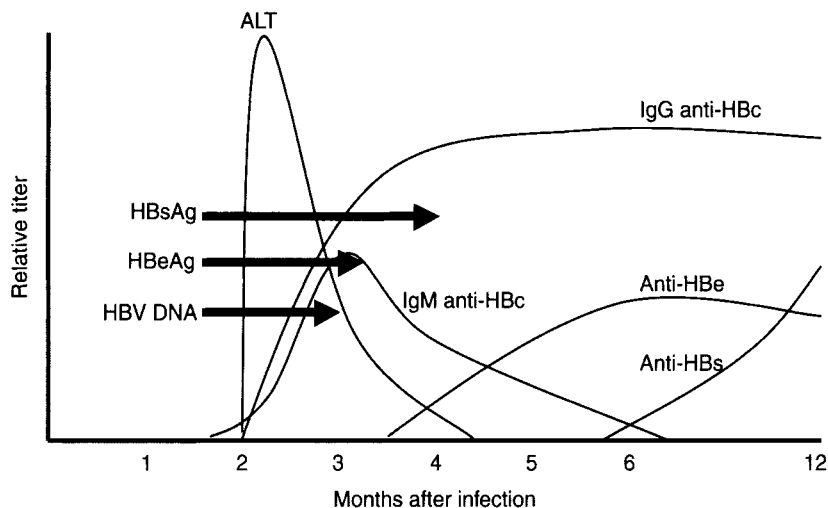

Fig. 14. Time course for appearance of viral antigens and antibodies in acute hepatitis B infection.

- Antibody to core antigen
- Detected after appearance of HbsAg
- Used to confirm HBV infection when HBsAg and Anti-HBs are absent (window phase)
- Anti-HBe
 - Antibody to HBeAg antigen-protective properties
 - Associated with low risk of infectivity in presence of HBsAg

Molecular Methods

Qualitative

- ◆ Cobas AmpliScreen HIV-1/HCV/HBV Tests (Roche Molecular Diagnostics)
 - It detects HBV DNA in human plasma
 - It is intended to be used to screen donors for HBV DNA
 - LOD is 100 copies/mL
 - It targets the *S* gene

Quantitative

- ◆ Used to establish baseline viral load (prior to therapy) and to monitor changes in viral load during therapy
- ◆ Digene HBV DNA hybrid capture II (Digene Corporation, Gaithersburg, MD)
 - Detection and quantitation of HBV DNA in serum
 - LOD: 4700 HBV DNA copies/mL
 - Quantitative range: 1.4×10^5 and 1.7×10^9 HBV copies/mL
- ◆ PCR—Amplicor HBV Monitor and its semi-automated Cobas HBV Amplicor Monitor test (Roche)
 - Detection and quantitation of HBV DNA in serum or plasma
 - Uses the primers HBV-104UB and HBV-104D to amplify a 104-bp sequence within the highly conserved pre-core/core region of the HBV genome

- Equally amplifies genotypes A-E and reduces amplification of genotype F and G
- LOD: 200 copies/mL
- Quantitative range: 1000–40,000,000 copies/mL

- ◆ Real-time PCR—LightCycler® (Roche Applied Science, Indianapolis, IN)/FRET hybridization probes

- It targets 259-bp fragment of *S* gene
- Quantitative range: $250-5 \times 10^8$ copies/mL

- ◆ Real-time PCR—Roche TaqMan Assay

- Utilizes FRET technology and probes based on the detection of amplicon during temperature cycling
- It targets *S* gene
- LOD: 50 copies/mL
- Quantitative range: 5–200,000,000 HBV IU/mL (3.0×10^7 copies/mL; 1 IU = 5.26 copies)

- ◆ bDNA assay—(Versant Hepatitis B Virus DNA 3.0 Assay) (Bayer Corporation)

- signal amplification directed to the 5' NC region and core regions of the HCV genome
- Microwell plate format
- LOD: 2000 copies/mL
- Quantitative range: 2.0×10^3 to 1.0×10^8 HBV DNA copies/mL
- Equivalent detection of genotypes A through F

Genotyping and Mutation Analysis

- ◆ Currently used mainly for epidemiological purposes, rarely needed for clinical purposes
 - Line probe assay-LiPA; INNO-LiPA HBV Genotyping assay, (Innogenetics N.V., Ghent, Belgium)
 - This method is based on the reverse hybridization principle, such that biotinylated amplicons hybridize to specific oligonucleotide probes that are

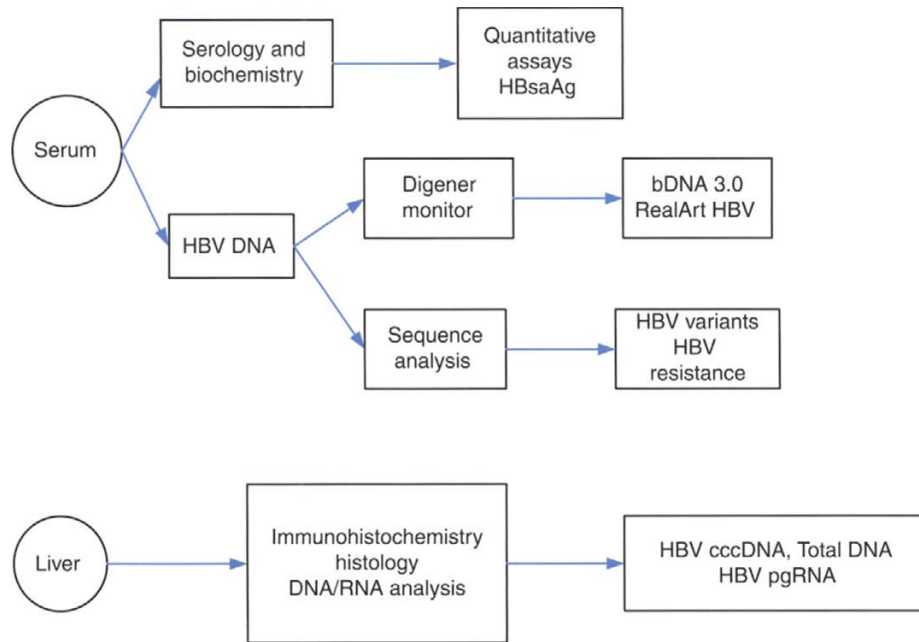

Fig. 15. An outlines of the HBV assays available for testing of serum and liver biopsy samples.

immobilized as parallel lines on membrane-based strips. The amplified region analyzed overlaps the sequence encoding the major hydrophilic region of HbsAg

- TRUGENE HBV Genotyping Kit (Bayer Corporation):
 - Sequencing and phylogenetic analysis of the pre-S1/pre-S2 region of the HBV genome
 - Identify HBV genotype, drug-resistance mutations, and anti-HBs escape mutations based on comparison of DNA sequence

Pitfalls

- ◆ The analytical sensitivity and specificity of current real-time PCR assays allow for accurate quantification over a range of approximately 7–8 logs. They are not sufficient to quantify the very high HBV DNA levels that can be found in certain HBV-infected patients, which necessitates retesting these samples after dilution, a factor of quantification errors
- ◆ Equal quantification of all HBV genotypes and robustness of quantification in the case of nucleotide polymorphisms has not been validated for the current commercial real-time PCR assays
- ◆ Lack of standardized HBV DNA reportable units (such as copies/mL or genome equivalents/mL or IU/mL)
- ◆ Not all assays are currently registered for use with plasma and serum
- ◆ Precise cut-off thresholds for HBV DNA have not been established to guide medical decisions

Clinical Utility

- ◆ Viral load testing is used for assessing and monitoring therapy response in HBV infections (**Figure 15**)
- ◆ In HBV carriers with active liver disease, HBV DNA loads are measured not only to assess patients regarding the need for either interferon- α or lamivudine (a DNA polymerase inhibitor) anti-viral therapy but also to monitor their effectiveness
- ◆ An increase in HBV viral load is also used as a marker of the emergence of lamivudine-resistant viral mutants
- ◆ Active chronic infections with HBV treated with lamivudine require surveillance for the emergence of lamivudine-resistant viral mutants. During lamivudine monotherapy point mutations at the active site of the polymerase gene (YMDD variants, i.e., specific amino acid motifs, Y = tyrosine, M = methionine, D = aspartate) occur with a frequency of 14–32% after 1 year in phase III studies, and in 42% and 52% of Asian patients after 2 and 3 years of therapy, respectively. The emergence of lamivudine resistance is detected by a rise in HBV viral load and confirmed by sequencing the active site of the DNA polymerase gene
- ◆ The presence of HBV pre-core mutants may cause active liver disease despite the absence of HBeAg, the common marker for active hepatitis in hepatitis B infection. This may be due to either a premature stop codon point mutation in the pre-core gene (*G1896A*) or a mutation in the basal core promoter region downregulating HBeAg production, both of which can only be reliably detected genotypically

CYTOMEGALOVIRUS (CMV)

General Characteristics

- ◆ Member of Herpes family (type 5) characterized by 230-bp double-stranded linear DNA virus (**Figure 16**) with 162 hexagonal protein capsomeres surrounded by three distinct layers: a matrix or tegument, a capsid, and an outer envelope
- ◆ CMV can reside latent in the salivary glands cells, endothelium, macrophages, and lymphocytes. CMV infection is asymptomatic in immunocompetent patients
- ◆ The virus acts by blocking cell apoptosis via the mitochondrial pathway and causing massive cell enlargement, which is the source of the virus name
- ◆ Clinically symptomatic patients are infants and immunocompromised adults. For infants, the mode of transmission is from the mother via the placenta, during delivery or during breast feeding
- ◆ For adults, CMV transmission occurs from close contact with individuals excreting virus in saliva, urine, and other bodily fluids. Transmission of CMV has been reported from blood transfusion and organ transplant
- ◆ By the age of thirty, approximately 40% of individuals are infected by CMV; by the age of 60, 80–100% of the population has been exposed to the virus

Clinical Presentation

- ◆ CMV elicits both humoral and cellular immune responses. CMV presents as primary, latent, reactivated, and reinfection
- ◆ Infectious CMV may be shed in the bodily fluids of any previously infected person, and thus may be found in urine, saliva, blood, tears, semen, and breast milk. The shedding of virus may take place intermittently, without any detectable signs
- ◆ The incidence of primary CMV infection in pregnant women in the United States varies from 1–3%. Healthy pregnant women are not at special risk for disease from CMV infection. When infected with CMV, most women have no symptoms and very few have a disease resembling mononucleosis. It is their developing unborn babies that may be at risk for congenital CMV disease. CMV remains the most important cause of congenital viral infection in the United States
- ◆ In infants and young children, typical features of the infection include hepatosplenomegaly, extramedullary cutaneous erythropoiesis, and thrombocytopenia and petechial hemorrhages. Encephalitis often leads to severe mental and motor retardation
- ◆ For immunocompromised patients, CMV disease is an aggressive condition. CMV hepatitis can cause fulminant liver failure. CMV infection can also cause CMV retinitis and CMV colitis

Diagnostic Methods

Specimens

- ◆ Whole blood, urine, CSF, amniotic fluid, bone marrow, and biopsies

Conventional Tests

- ◆ Histology and cytology with the use of IHC studies
 - General:
 - Cytomegalic intranuclear (owl's eye) inclusions in tissue are pathognomonic for CMV infection
 - Advantage:
 - Specific and Definitive diagnosis
 - Confirm end organ disease along with virus infection diagnosis
 - Pitfalls
 - Invasive procedure required
 - Insensitive
- ◆ Viral culture
 - Conventional culture
 - Human embryo lung fibroblasts are most commonly used
 - The specimen is inoculated into human embryo lung (HEL) cells and kept for 28 days with a blind passage at 14 days. CMV produces a typical focal viral cytopathic effect (CPE)
 - Advantages:
 - Gold standard test for CMV detection
 - Able to recover other viruses from the same specimen
 - Pitfalls:
 - Low sensitivity compared with PCR and nucleic acid probe
 - Lack of quantitation
 - Long turnaround time
 - Sensitivity and specificity: overall sensitivity (59%) and specificity (80%)
 - Urine sensitivity/0.37, specificity/0.85
 - Saliva sensitivity/0.48, specificity/0.81
 - Blood sensitivity/0.45, specificity/0.92
 - Any sensitivity/0.69, specificity/0.77
 - TAT: 7–21 days
 - Shell vial assay
 - Shell vial culture with immunofluorescent antibodies (IFA) staining is a method used for the early diagnosis of CMV infection
 - In immunocompromised patients, a reported sensitivity of 78% and a specificity of 100% have been claimed
 - The shell vials are centrifuged at a low speed and placed in an incubator. After 24 and 48 hours, the cell culture medium is removed and the cells are stained

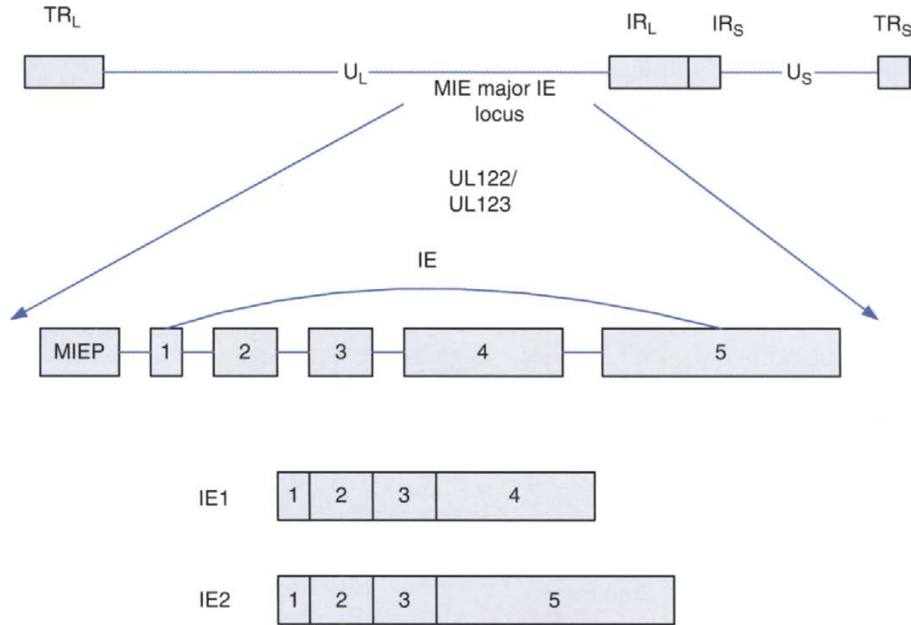

Fig. 16. CMV genome. MIEP-major IE promoter, U_L, unique long region; U_S, unique short region; TR, terminal repeat sequence; IR, inverted repeat sequence.

using a fluorescein-labeled anti-CMV antibody. The cells are read under a fluorescent microscope

- Advantages:
 - Higher sensitivity than conventional methods (68–100%)
 - May be quantitative
- Pitfalls:
 - May need large amount of biomass for virus recovery
- TAT: up to 48 hours

♦ Serological studies

– Immunoassay

- CMV immunoglobulin M (IgM) antibodies are detected in primary infection and lasts 3–4 months
- It is not detectable in recurrent infection except in immunocompromised patients where it is detectable in about a third of the cases
- CMV IgG is produced early in primary infection and persists lifelong. The detection of CMV IgG is useful as an “immune status screen” (seropositive individuals are not protected from reactivation or reinfection)
- CMV IgG avidity test to distinguish primary CMV infection from past or recurrent infection (reactivation or reinfection). CMV IgG avidity is low (<30%) in primary infection
- Prenatal diagnosis of congenital CMV infection is performed only in the case of primary maternal infection as transplacental transmission of CMV is higher in 40% of primary maternal CMV infection.

Whereas, transplacental CMV transmission is low in the case of recurrent infection 1–4%

– CMV antigenemia test

- This test is based upon the detection of pp65, a structural protein expressed on the surface of infected polymorphonuclear lymphocytes
- The number of infected leukocytes present has been correlated to the severity of infection
- Commercial assay:
 - CMV Brite Turbo Kit (Biotest Diagnostics Corp., Danville, NJ). FDA approved assay
- Advantages:
 - Inexpensive kits are commercially available
 - May be able to detect CMV before development of symptoms
- Pitfalls:
 - Labor-intensive
 - Requires skilled personnel
 - Subjective interpretation
 - Requires immediate processing within 6–8 hours of specimen collection
 - Poor sensitivity in urine samples. The assay is adversely affected by low leukocyte counts
- TAT: 8–24 hours

Molecular Methods

Qualitative

- ♦ Nucleic acid hybridization
 - CMV hybrid capture assay (Digene): FDA cleared

- Unlabeled CMV probes hybridize with viral DNA, then immobilized on a solid phase before being measured by conjugated anti-hybrid antibody
 - Detection range (1400–6000 copies/mL)
 - TAT: 6–48 hours
- bDNA probe assay (Chiron, Emeryville, CA): use artificial molecule to amplify the signal of the bound probe
 - TAT: >18 hours
 - LOD—900 CMV copies per 10⁶ leukocytes
 - It requires large number of polymorphonuclear leukocyte (PMN), which limits the result of patients with low leukocytes count
- ◆ Direct measurement of viral replication
 - NucliSens CMV pp67 Assay (Organon Teknika Inc., Durham, NC), FDA cleared:
 - NucliSens CMV pp67 measures replication of CMV in blood. Using NASBA RNA amplification technology
 - This assay detects messenger RNAs coding for the matrix tegument protein pp67 of CMV, a true late protein, which is only expressed during viral replication
 - The NASBA technology selectively amplifies RNA in a DNA background and allows direct testing in whole blood
 - It is a direct route for diagnosing an active CMV infection and monitoring treatment efficacy
 - Advantages
 - Small amount is required (100 µL blood)
 - Specimens may be stored long-term
 - Pitfalls
 - Many steps involved
 - TAT: 6–8 hours
- Primers specific for the CMV polymerase gene amplify a 362-bp gene fragment
- An internal QS is added at a known concentration during specimen processing so that extraction and recovery of DNA, in addition to amplification and detection, can be monitored
- The lower limit of sensitivity of the assay is 400 copies/mL of plasma. The linear range of the assay is 400–400,000 copies of CMV DNA per mL
- The inherent sensitivity of molecular detection of CMV poses a problem since latent CMV genomes, present in most seropositive individuals, may be detected. Therefore, it is critical to adjust the sensitivity of the PCR so that latent genomes are not detected
 - TAT: next day (6–48 hours)
- ◆ Real-time PCR
 - Real-time TaqMan PCR (Prism 7700, Applied Biosystems). Various home-brew methods have been described. (Table 4) lists some examples of such methods
 - Real-Time LightCycler PCR. Various home-brew methods have been described. (Table 5) lists some examples of such methods
 - Pitfalls
 - False-positive results due to contamination (detected by negative control)
 - False-negative results due to amplification inhibition (detected by internal control) or due to a loss of bacteria during specimen preparation
 - PCR assays are not standardized and variations in sample handling and laboratory methods can affect the sensitivity of the assay

Quantitative

- ◆ PCR
 - Advantages:
 - Rapid
 - Assay sensitivity allows detection of virus before symptoms develop
 - Less expensive
 - Pitfalls:
 - False-positive
 - Contamination must be prevented
 - Amplicor CMV Monitor test (Roche Molecular Systems) is a quantitative microtiter-based PCR assay
 - CMV viral DNA was quantitated by coamplifying a region of the CMV DNA polymerase gene in the presence of a known quantity of quantitative standard

Clinical Utility

- ◆ Quantitative PCR determination of CMV viral load in solid organ transplant recipients can predict CMV disease and relapse (Table 6), as well as for initiating anti-viral therapy
- ◆ Viral load testing in patients with HIV infection is currently used to predict CMV disease (Table 6) and to monitor the efficacy of treatment

Laboratory Methods for Anti-Viral Susceptibility Testing of CMV Isolates

- ◆ Phenotypic methods (Table 7)
 - Plaque reduction assay
 - The gold standard for anti-viral susceptibility testing of CMV
 - In this assay, a standardized inoculum of a stock virus is inoculated into cultures and incubated in the presence of the anti-viral agent
 - The cultures are then observed for the presence of viral plaques

Table 4. Various Real-Time TaqMan “Home-Brew” Methods for Quantitation of CMV

Reference	Specimen	Target	Quantitative standard	Reporting units
Machida et al. 2000	Bone marrow transplant; blood samples from patients and healthy volunteer	US17 gene	Range: 10–10 ⁷ CMV DNA copies/well	Copies of CMV DNA/500 mg of DNA (blood), copies CMV DNA/100 µL plasma
Nitsche et al. 2000	Plasma; bone marrow transplant patients	Major immediate—early gene	As a positive control, a plasmid containing the target sequence from the target gene was used with 10 ¹ –10 ⁷ plasmids/assay	Copies CMV genome/mL plasma
Tanaka et al. 2000	Peripheral blood leucocytes, plasma	Immediate—early gene	Range from 6 to >10 ⁶ copies of CMV DNA. Plasmid containing the IE gene used to develop a standard curve for quantitative results	Copies CMV DNA/10 ⁶ cells
Gault et al. 2001	Blood (peripheral blood leucocytes)	UL83 (pp65 gene)	Plasmid containing one copy of UL83 target sequence used as a quantitative standard plasmid containing human genomic DNA (albumin gene) coamplified with specimen DNA	Copies CMV DNA/2 × 10 ⁵ leucocytes

Adapted from Clin Microbiol Rev. 2006; 19(1):165–256

Table 5. Various Real-Time LightCycler PCR “Home Brew” Methods for Quantitation of CMV

References	Specimen	Target	Quantitative standard	Reporting units
Kearns et al. 2001	Blood	Glycoprotein B gene	Range: 10 – >2 × 10 ⁵ CMV DNA copies. <i>EcoRI</i> plasmid quantified and linearized and used as quantitative standard	DNA copies/µL
Ando et al. 2002	Aqueous humor; patients with clinical retinitis	Glycoprotein B gene	Range: 10 ¹ –10 ⁴ copies/µL	–
Kearns et al. 2002	Urine and respiratory samples	Glycoprotein B gene	Range: 2 × 10 ³ –5 × 10 ⁸ CMV DNA copies/µL	DNA copies/µL

Adapted from Clin Microbiol Rev. 2006;19(1):165–256

- The IC₅₀ of the agent for the isolate is defined as the concentration of agent causing a 50% reduction in the number of plaques produced
- Plaque reduction assays are labor-intensive
- Plaque reduction assays are limited by the excessive time required to complete the assay (4–6 weeks) and the lack of a standardized method validated across different laboratories
- In addition, repeated passage of isolates to prepare viral stocks may influence the results of assays by selecting CMV strains that are not representative of the original population of the viruses
- DNA hybridization assay
 - Whole genomic DNA is extracted and transferred by capillary action onto negatively charged nylon membranes after incubation with a specific agent
 - The membranes are hybridized to a ¹²⁵I-labelled human CMV probe (Diagnostic Hybrids, Athens, OH), rinsed, washed, and counted in a gamma counter

Table 6. Quantative PCR Thresholds and Outcomes in Different Patient Settings

Setting	References	Number of patients	Breakpoints or associations	Outcome
Renal transplant	Fox et al.	103	>10 ^{6.5} copies/mL of urine	Higher association with CMV disease Highly predictive for CMV disease
	Kuhn et al.	58	>1000 DNA copies/10 ⁶ copies of cellular DNA. Each 0.25 log ₁₀ increase in baseline CMV DNA load in urine	
	Cope et al.	196	>500 DNA copies per 1 µg of total DNA	2.8-fold increase in CMV disease risk
	Toyoda et al.	25	>500 DNA copies per 1 µg of total DNA	Increased risk of CMV disease
Liver transplant	Cope et al.	162	Each 0.25 log ₁₀ increase in baseline CMV DNA load in whole blood 10 ^{4.75} –10 ^{5.25} DNA copies/mL	2.7-fold increase in CMV disease
			Increased disease probability	
Cardiac transplant	Toyoda et al.	95	>500 DNA copies per 1 µg of total DNA	Increased risk of CMV disease
Allogenic marrow transplant	Zaia et al.	110	>10 ⁴ DNA copies/mL of plasma	Increased risk of CMV disease after 100 post-transplant Odds ratio for disease, 6.46 (95% confidence interval 1.5–27.4) Odds ratio for disease, 10.66 (95% confidence interval 1.8–60.5)
	Gor et al.		>10 ⁴ DNA copies/mL of whole blood >10 ⁵ DNA copies/mL of whole blood	
HIV	Shinkai et al.	94	>100 DNA copies/µL of plasma	High predictive values for CMV disease
	Rasmussen et al.	75	>320 copies/µg of DNA >32 copies per 25 µL of plasma	Sustained level associated with CMV retinitis
	Bowen et al.	97	Each 0.25 log ₁₀ increase in baseline CMV DNA load in whole blood	1.37-fold increase in risk in CMV disease
	Spector et al.	201	Each log ₁₀ increase in baseline CMV DNA load in plasma	3.1-fold increase in risk in CMV disease 2.2-fold increase in mortality

Adapted from *Clin Microbiol Rev.* 1998;11(3) 533–554

- Mean hybridization values (in counts per minute [cpm]) for each concentration of anti-viral agent are calculated and expressed as a percentage of the cpm in control cultures
- The IC₅₀ is defined as the concentration of anti-viral agent resulting in a 50% reduction in viral nucleic acid hybridization values (i.e., DNA synthesis) compared with the hybridization values of controls
- Disadvantage of DNA hybridization assays is that they require the use of radiolabeled probes
- DNA hybridization assays have the advantage over plaque reduction assays of eliminating the variation due to subjective errors resulting from plaque counting by different individuals
- Other phenotypic methods: viral production is measured by using IFA-, immunoperoxidase-, ELISA-, or flow cytometry-based methods for detection and quantitation of cells expressing CMV antigens (immediate-early, early, or late)
- ◆ Genotypic methods
 - The mutation of the viral phosphotransferase gene (*UL97*) coding sequence, which may confer resistance only to ganciclovir
 - *UL97* mutation occurs at three specific sites, within a 700-nucleotide region at the 3' end of the gene, including point mutations within codon 460 and 520 and either point mutations or deletions within the codon range 590–607

Table 7. Ganciclovir, Foscarnet, and Cidofovir IC₅₀s Used in Clinical Studies to Define Resistant CMV Isolates

<i>Method</i>	<i>Ganciclovir</i> <i>IC₅₀ (μM)</i>	<i>Foscarnet</i> <i>IC₅₀ (μM)</i>	<i>Cidofovir</i> <i>IC₅₀ (μM)</i>
Plaque reduction assay	≥9		
	≥9	≥300	
	≥8	≥324	≥2.1
	≥12	≥400	
	≥12		
DNA hybridization assay	≥6	≥400	≥2
	Five times higher than IC ₅₀ for AD 169		
	>6 >6	>400	≥2

Adapted from Clin Microbiol Rev. 1999;12(2): 286–297

- The more rare mutations in the viral polymerase gene (*UL54*) may confer resistance to any or all of the three most commonly used drugs (ganciclovir, foscarnet, or cidofovir); occur in regions between codons 300 and 1000
- Mutations in *UL54* are often accompanied by mutations in *UL97*, showing higher levels of resistance to ganciclovir with possible cross-resistance to foscarnet and/or cidofovir
- Detection of mutations is based on PCR amplification of the specific region of the genome followed by restriction enzyme analysis or direct sequencing of the amplification product
- ◆ Pitfalls
 - Using restriction enzyme analysis, not all of the presently confirmed resistance mutations are accompanied by alteration of known restriction enzyme recognition sites, which lead to false-negative results. In addition, base changes not associated with drug resistance can produce new restriction sites, which lead to false-positive results
- PCR assays are not standardized and variations in sample handling and laboratory methods can affect the sensitivity of the assay
- Well-defined CMV DNA standards are needed to avoid variation of viral load values obtained with commercial and home-brew assays
- ◆ Clinical utility
 - The standardization of automated sequencing methods and the characterization of mutations associated with drug resistance will offer routinely genotypic-resistance testing in a time frame that impacts clinical care

EPSTEIN-BARR VIRUS (EBV)

General Characteristics

- ◆ Member of Herpes Family (type 4) characterized by dsDNA, icosahedral capsid, and a glycoprotein-containing envelope
- ◆ The genome has been sequenced: 172,282 bp of DNA encoding for 80 genes
- ◆ Most common mode of transmission of EBV is through exposure to infected saliva from asymptomatic individuals. Virus is relatively fragile and does not survive long outside the human host fluids

- ◆ Remains latent in B lymphocytes, affecting >95% of population
- ◆ Critical viral target genes: EBV nuclear antigen (*EBNA1*), latent membrane protein (*LMP1*), and *LMP2* (**Figure 17**)

Clinical Presentation

- ◆ EBV is a ubiquitous virus, which causes persistent, latent infection that can be reactivated. >90% of the adult population is estimated to demonstrate serologic evidence of prior exposure with EBV

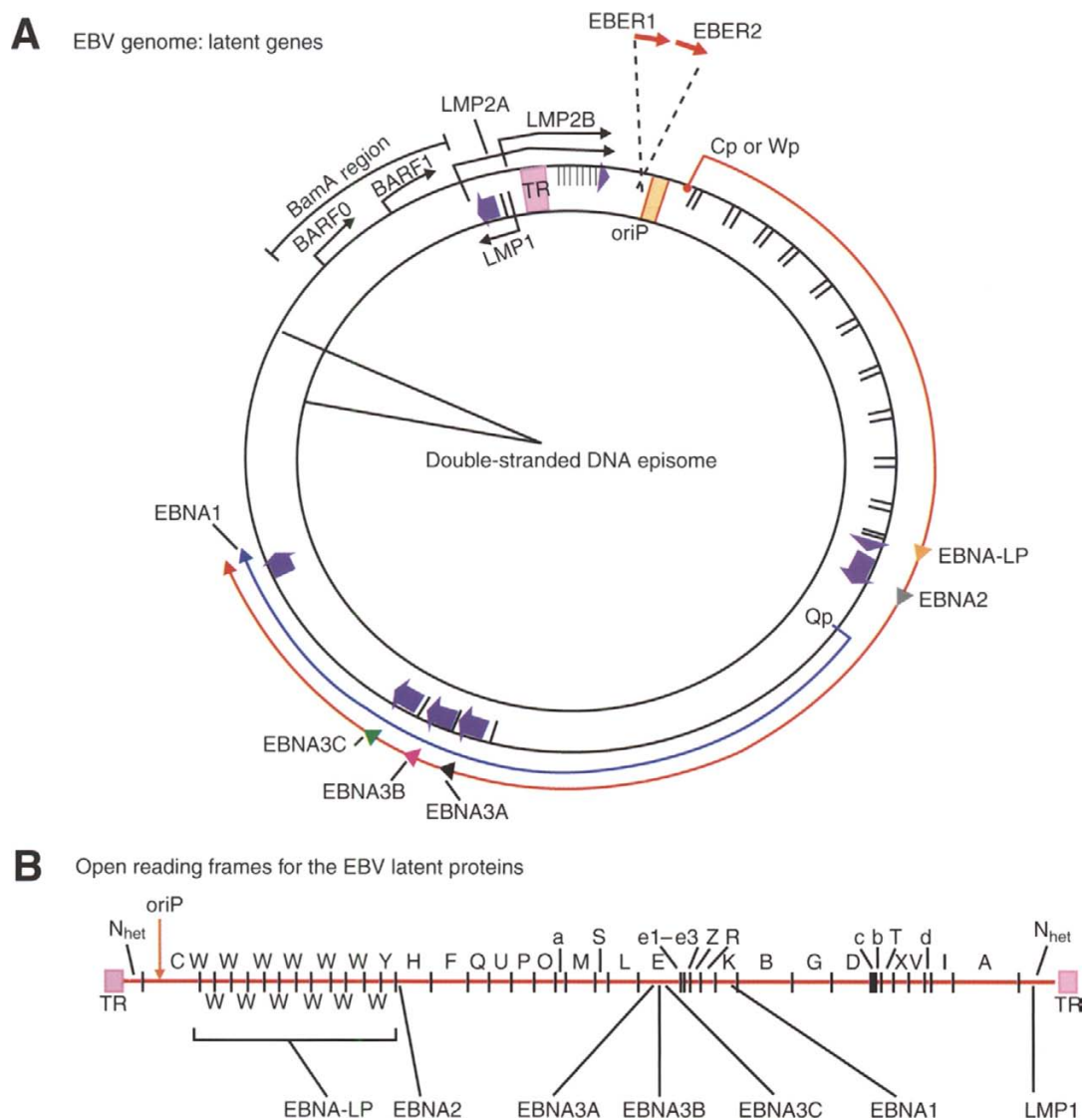

Fig. 17. EBV genome structure. (Adapted from Paul G. Murray¹ and Lawrence S. Young: Epstein–Barr virus infection: basis of malignancy and potential for therapy.)

- ◆ Primary infection in young children is often asymptomatic or causes non-specific minor illness
- ◆ For adolescents and adults, primary infection is typically manifested as infectious mononucleosis (IM), usually a self-limiting condition characterized by fever, sore throat, myalgias, lymphadenopathy, and hepatosplenomegaly
- ◆ A strong association between EBV and Burkitt's lymphoma in children of Central Africa/New Guinea and nasopharyngeal carcinoma among Chinese males
- ◆ EBV is associated with a variety of disorders in the AIDS population, i.e., oral hairy leukoplakia and CNS lymphoma
- ◆ Patients undergoing transplantation are prone to develop post-transplant lymphoproliferative disease

Diagnostic Methods

Specimens

- ◆ Whole blood, plasma, CSF, and biopsy

Conventional Tests

- ◆ Serologic
 - Antibody
 - Heterophile antibody
 - Present in 90% of adults during the course of illness
 - Non-specific serologic response to EBV infection
 - Classic Paul-Bunnell test
 - Measures agglutination of sheep RBCs by patient serum; limited by false-positive agglutinins in sera

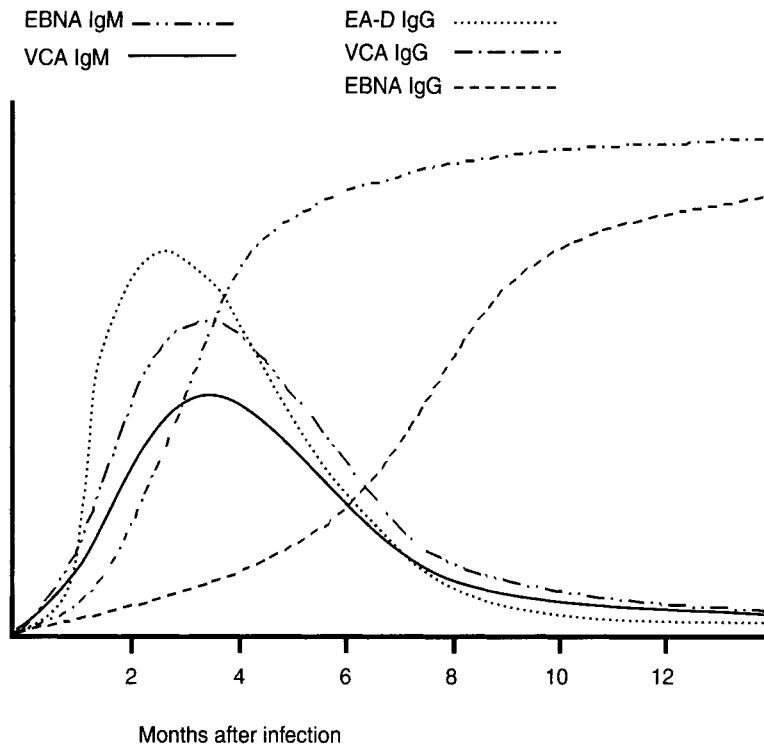

Fig. 18. Time course for appearance of antibodies in EBV infection.

of normal individuals (Forssman agglutinins) and patients with serum sickness.

- Monospot test: agglutination of horse red blood cells on exposure to heterophile antibodies
- Viral capsid antigen antibody (**Figure 18**)
 - IgM—indicates recent infection, lasts only 4–8 weeks
 - IgG—peaks during week 3–4 of infection, can persist for >1 year or entire lifetime
- Early antigen antibody, Anti-D
 - Diffusely nuclear and cytoplasmic staining of infected cells
 - Present in 40% of IM patients
 - Persists for 3–6 months
 - Detected in patients with nasopharyngeal carcinoma
- Early antigen antibody, Anti-R
 - Stains cytoplasmic aggregates
 - Found in atypical protracted cases of IM
 - Found in patients with African Burkitt's lymphoma
- Epstein Barr nuclear antigen antibody
 - Appears 3–4 weeks after infection
 - Persistent for life
 - Found in patients with Burkitt's lymphoma

Molecular Methods

In situ Hybridization (*Biogenex, San Ramon, CA*)

- ◆ Used for tissue biopsy

- ◆ The EBV (EBER) EBV-encoded RNA probe is specific for EBER RNA transcripts and is intended for the detection of latent EBV infection
- ◆ The EBV Not I/Pst I DNA probe is specific for the Not I/Pst I repeat sequence of EBV and is intended for the detection of active EBV infection

Quantitative-Competitive PCR

- ◆ Specific primers are specifically designed to the EBV viral latent membrane protein 2a (*LMP2a*) and internal competitor DNA (ssDNA) that is confirmed against a known number of Namalwa cells (B-cell lymphoma cell line containing two integrated copies of the EBV viral genome per cell)
- ◆ Four separate PCR reaction tubes each containing internal competitor DNA (8 copies/ μ L, 40 copies/ μ L, 200 copies/ μ L, or 1000 copies/ μ L) are placed in competition with EBV-specific primers for amplification of patient DNA
- ◆ PCR amplicons are examined by electrophoresis through a 2% agarose gel and visualized using a gel-imaging documentation system. The band densities are quantitatively measured using Bio-Rad's (Hercules, CA) Quantity One software and used to calculate EBV copies

Real-Time PCR (*Roche LightCycler analyte specific reagent [ASR]*)

- ◆ Detection of *LMP* gene of EBV viral genome
- ◆ EBV is amplified with specific primers in a PCR reaction. The amplicon is detected by fluorescence using a specific pair of hybridization probes
- ◆ A melting curve analysis is performed after the PCR run to differentiate positive samples from non-EBV species, i.e., other Herpes virus family

- ◆ The internal control is added already to the lysed sample before the purification step and co-purified/amplified with the EBV DNA from the specimen in the same PCR reaction (dual color detection)

Sensitivity and Specificity

- ◆ LOD for real-time LC PCR is 75–100 copies/mL. The linear range is 100–10⁵ copies/mL
- ◆ Quantitative competitive PCR (QC-PCR) is a semi-quantitative method and approximately 10-fold less sensitive than real-time PCR

Pitfalls

- ◆ QC-PCR requires analysis of absolute lymphocyte count, which inversely affects viremia; real-time PCR does not
- ◆ It is important to note that the EBV real-time PCR assay requires sequential analysis of run data prior

to result reporting to prevent false-positives i.e., pseudoamplification and amplification of non-EBV species and false-negatives, i.e., shifted melting curve for EBV variants

- ◆ PCR assays are not standardized and variations in sample handling and laboratory methods can affect the sensitivity of the assay

Clinical Utility

- ◆ Serial viral load testing can be used to monitor disease burden and assess efficacy of immunosuppressive therapy in post-transplant patients
- ◆ Detection of EBV in tissue biopsy assists the diagnosis of EBV-related malignancies, including lymphoma and nasopharyngeal carcinoma

HERPES SIMPLEX VIRUS (HSV)

General Characteristics

- ◆ Family of enveloped icosahedral nucleocapsid viruses with total nine members
- ◆ HSV type 1 and type 2 demonstrate an 83% DNA homology in protein-coding regions
- ◆ The genetic map of the two viruses is colinear and the genomes are of approximately the same size, HSV-1 of 152 kbp and HSV-2 of 155 kbp
- ◆ Humans are the only known reservoir
- ◆ Direct contact with lesion or secretions is necessary for transmission. After direct exposure to infectious material (i.e., saliva and genital secretions), initial viral replication occurs at either the skin or mucous membrane entry site, typically of epithelial cells
- ◆ HSV 1 and HSV 2 are most common. HSV 1, acquired early in life, is usually associated with oral lesions. HSV 2, acquired after onset of sexual activity, is associated with genital lesions. Both viral types can cause oral-facial and genital infections and maybe clinically indistinguishable
- ◆ Risk of transmission of HSV from HSV-infected mother during vaginal delivery to infant is 50%, estimated to be between 1 in 2000 and 1 in 5000 births
- ◆ Beyond the neonatal period, most childhood HSV infections are caused by HSV-1. The seroprevalence of HSV-1 antibodies increases with age and is 20% by age 5 years. No increase occurs until age 20–40 years, when 40–60% of individuals are HSV-1 seropositive
- ◆ A stimulus (e.g., physical or emotional stress, fever, and ultraviolet light) causes reactivation of the virus in the form of skin vesicles or mucosal ulcers, with symptoms less severe than primary infection. Latent HSV can be reactivated from the trigeminal, sacral, and vagal ganglia

Clinical Presentation

- ◆ Primary infection usually occurs with 2–20 days incubation period
- ◆ Cutaneous vesicles characterized by ulcers that eventually pustulate, dry, and crust; mucosal vesicles appear as shallow punctuate ulcers that often coalesce
- ◆ Primary herpetic gingivostomatitis/pharyngotonsillitis (HSV 1): most cases are asymptomatic. Most cases are between 6 months and 5 years. Characterized by generalized malaise, fever, linear gingivitis, and lymphadenopathy
- ◆ Primary herpes genitalis (HSV 2): genital HSV-2 infection is twice as likely to reactivate and recurs 8–10 times more frequently than genital HSV-1 infection. A classic vesicular rash may be noted; or progressive lesions (pustules or painful ulcerative lesions). Lesions may persist for as many as 3 weeks. Painful inguinal lymphadenopathy, dysuria, and vaginal discharge are frequent complaints. Most primary genital HSV infections are asymptomatic, and 70–80% of seropositive individuals have no history of symptomatic genital herpes. HSV can be transmitted in the presence or absence of symptoms
- ◆ Primary cutaneous herpetic infections can occur in wrestlers and rugby players with contaminated abrasions (herpetic gladiatorum or scrumpox)
- ◆ HSV keratitis presents with an acute onset of pain, blurring of vision, chemosis, conjunctivitis, and characteristic dendritic lesions of the cornea
- ◆ HSV meningitis
 - 1–7% of all cases of aseptic meningitis
 - Frequency: HSV-2 >> HSV-1
 - 20–45% with meningitis have recurrent episodes

- HSV accounts for 10–20% of all cases of sporadic viral encephalitis in the United States. The clinical hallmark of HSV encephalitis has been the acute onset of fever and focal neurologic (especially temporal-lobe) symptoms. Clinical differentiation of HSV encephalitis from other viral encephalitides, focal infections, or non-infectious processes is difficult
- Neonates (<6 weeks) have the highest frequency of visceral and/or CNS infection of any HSV-infected patient population
- ◆ HSV infection of visceral organs usually results from viremia, and multiple-organ involvement is common
- ◆ Recurrent infection at sites of primary infection
 - Activation of latent virus from neurons of cervical ganglia (herpes labialis, HSV 1) or sacral ganglia (HSV 2)
 - Self-inoculation of fingers and thumbs (herpetic whitlow) can occur in children with orofacial herpes, although less common
 - Anti-viral prophylaxis recommended for persistent recurrent cases
 - Some cases of erythema multiforme are believed to represent an allergic response to recurrent HSV infection
- Schell vial assay
 - A centrifugation-enhanced culture technique used to obtain rapid culture results. Generally less sensitive than conventional culture
 - The test can detect HSV in shell-vial cultures (MRC-5 cells) before the development of CPE (pre-CPE)
 - IF staining of shell vial for viral detection and typing
- ◆ Cytology
 - Intranuclear inclusion bodies
 - Multinucleated, molded giant cells
 - Margination of nuclear chromatin
- ◆ Serological studies
 - ELISA
 - Performed on fluids or other samples using HSV-specific antibody that is bound to a solid surface
 - Antibody captures antigen to which anti-HSV antibodies labeled with enzymes are added. These attach to the bound antigen and cause a color change
 - IF and immunoperoxidase assays
 - Detect HSV antigen in smears or tissues. HSV-specific antibodies are labeled with fluorescent dyes or enzymes (peroxidase)
 - Labeled antibodies are incubated with the specimen and bind to HSV antigens in the specimen, if present
 - Attached fluorescent dye or enzyme can be visualized in appropriate regions of infected cells under a microscope
 - Used in conjunction with shell vial culture
 - Enzyme-Linked Virus Inducible System (ELVIS). ELVIS is a method, with no specific manufacturer.
 - Technique combines cell culture amplification with HSV-activated reporter genes
 - The test produces results that are equal to conventional culture

Diagnostic Methods

Specimens

- ◆ Vesicular fluid, ulcerated lesions, pharyngeal and throat swabs, urine, CSF, autopsy and biopsy material, ocular exudates, and vaginal swabs
- ◆ Specimen is best collected within the first 3 days after appearance of lesion but not >7 days

Conventional Tests and Problems

- ◆ Viral culture
 - Conventional
 - Cell culture requires the collection of live virus samples that require special care in transport to the laboratory to retain viability. When viable samples are used, culture can be highly specific (if typing is performed) and positive results are generally reliable
 - The sensitivity of culture declines rapidly as lesions begin to heal and for this reason frequently non-positive result can be falsely negative. Type-specific serology tests should be used in these cases to confirm a clinical diagnosis of genital herpes
 - Many commercial cell lines are used (A-549, RK, ML, HNK, MRC-5, and so on)
 - Diagnosed by observation of CPE induced by virus, which usually occurs in 1 week after initial inoculation

Molecular Methods

Polymerase Chain Reaction

- ◆ Most home-brew methods design primers to the thymidine kinase gene. Due to the lack of standardization, variation of the sensitivity and specificity is observed

Real-time PCR (*LightCycler—HSV 1/2 Detection Kit, Roche*)

- ◆ Detection and differentiation of HSV type 1 and type 2 (HSV 1/2)
- ◆ HSV 1/2 is amplified with specific primers in a PCR reaction. The amplicon is detected by fluorescence using a specific pair of hybridization probes
- ◆ A melting curve analysis is performed after the PCR run to differentiate positive samples for HSV 1 or HSV 2. Melting points for HSV 1 and HSV 2 are significantly different (HSV-1 at 53.9°C, whereas HSV-2 at 67.1°C), and allows clear determination of the HSV type (**Figure 19**)

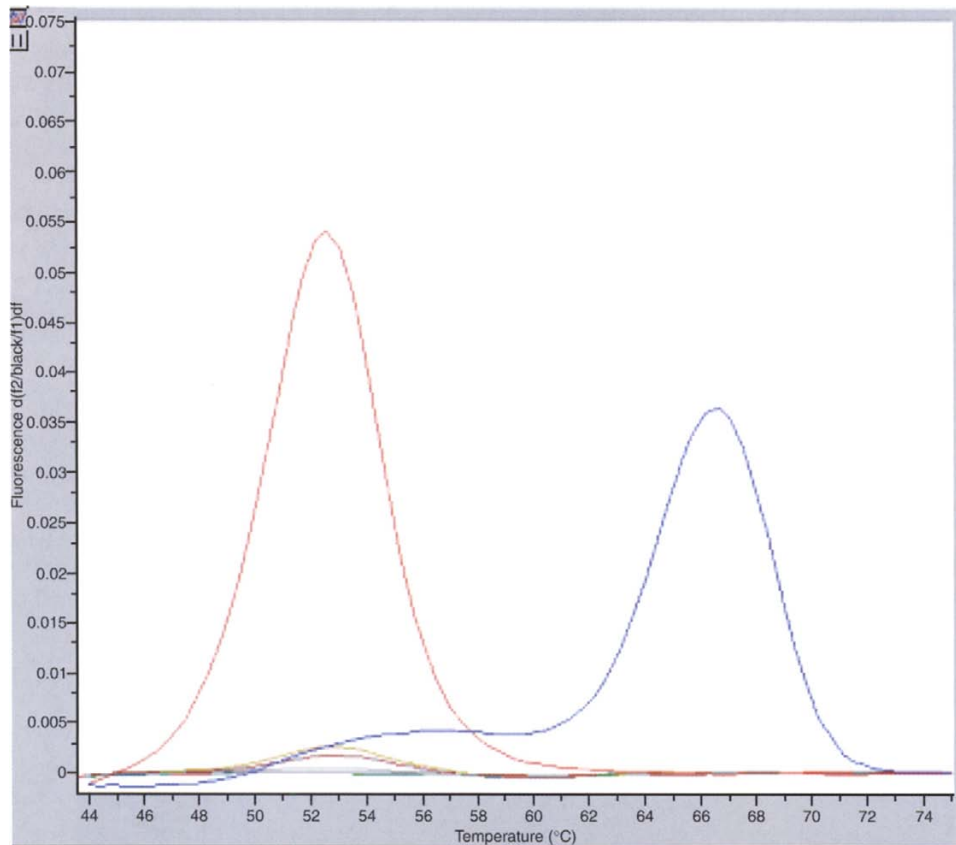

Fig. 19. Melting curve analysis of HSV1 and HSV2, HSV-1 positive samples result in a melting point signal at 53.9°C, whereas HSV-2 positive result in a melting point signal at 67.1°C. (Courtesy of Roche Diagnostics.)

- ◆ The internal control is added already to the lysed sample before the purification step and copurified/amplified with the HSV DNA from the specimen in the same PCR reaction (dual color detection)

Cepheid SmartCycler® (Cepheid, Sunnyvale, CA) System-HSV Non-Typing (ASR)

- ◆ It targets 92-bp region of the HSV type 1 and type 2 polymerase gene

Cepheid SmartCycler System HSV-Typing (ASR)

- ◆ It targets the glycoprotein D gene of HSV type 1 and the glycoprotein G gene of HSV type 2

Sensitivity and Specificity

- ◆ The lower LOD (analytical sensitivity) for HSV qualitative PCR is 25 copies/reaction (~1250 copies/mL)
- ◆ The sensitivity of PCR:
 - HSV in skin lesions (sensitivity of 83–100%) and specificity 100%
 - CSF: sensitivity 70–100%
- ◆ HSV was detected more frequently by PCR than by viral culture regardless of whether samples were obtained from HSV lesions, or from genital or oral secretions during a

period of sub-clinical shedding. Yield of virus positivity is four times greater by PCR than by culture, and the results are more reliable, especially in settings in which transport or climate may interfere with the yield from viral culture

- ◆ Due to the sensitivity of PCR, labs may now only offer PCR tests. Culture is used only when sensitivity testing is required
- ◆ CSF culture
 - Approximately 80% positive with first attack
 - 0% with recurrent episodes

Pitfalls

- ◆ Important to note that PCR assays are not standardized and variations in sample handling and laboratory methods can affect the sensitivity of the assay
- ◆ PCR cannot always diagnose HSV encephalitis in the first few days of illness and serial evaluations of CSF by PCR during the first week of illness is necessary

Clinical Utility

- ◆ Diagnosis of herpes encephalitis in neonates and immunocompromised patients by detection of HSV in CSF

- ◆ CSF PCR for HSV DNA should be performed in patients with febrile encephalopathy even in the absence of focal features, initial CSF pleocytosis, or abnormal CT. Mild or atypical HSV encephalitis may be associated with infection from HSV-1 or HSV-2
- ◆ In addition to CSF, other specimens can be used for PCR, including mucosal secretion, skin lesion, and so on
- ◆ Current treatment guidelines for herpes include three anti-viral therapies: acyclovir, famciclovir, and valacyclovir and should begin as soon as possible after symptoms begin. Anti-viral therapy may be effective when taken during onset of pro-dromal symptoms, i.e., tingling
- ◆ Anti-viral therapy will reduce the duration of outbreak by approximately 2 days
- ◆ Suppressive therapy is highly effective and can dramatically reduce the frequency of recurrences. Suppression can be continued for years with very low risk of toxicity or development of drug-resistant HSV. Suppressive therapy will also reduce the frequency of asymptomatic HSV shedding

VARICELLA ZOSTER (VZV)

General Characteristics

- ◆ Member of Herpes Family (type-3)
- ◆ The VZV genome is 125 kbp
- ◆ Isolated in patients with chicken pox (primary), subsequent latency followed by reactivation of virus, known as shingles (recurrent)
- ◆ Multiple recurrences are common and can be triggered by immunosuppression, exposure to cytotoxic drugs, radiation, and malignancy

Clinical Presentation

- ◆ Varicella (chicken pox)
 - Mild, self-limited illness common in school-aged children with fever followed by vesicular eruption on skin and mucous membranes
 - Spread by respiratory secretions with 10–14-day incubation period
 - More severe in adults, pneumonia common
- ◆ Herpes zoster (Shingles)
 - Recurrent infection, usually in adults that may be activated by trauma, neoplasm, or immunosuppression
 - Virus remains latent in sensory ganglia of spinal or cranial nerves causing dermatomal pain and vesicular eruptions, fever, and malaise. Commonly affects the trunk, but can involve any dermatome (**Figure 20**)
 - Associated with encephalitis and delayed cerebral vasculitis
- ◆ Zoster sine herpette occurs in the event of recurrence in the absence of vesicle formation
- ◆ Post-herpetic neuralgia: pain lasting >1 month after an episode, occurs in as many as 14% of affected individuals, particularly those over 60 years of age. Most neuralgias resolve within 1 year with 50% experiencing resolution within 2 months
- ◆ Ramsay Hunt syndrome: combination of cutaneous involvement of herpes zoster infection of external

auditory canal and ipsilateral facial and auditory nerve. Syndrome can cause facial paralysis, hearing deficits, and vertigo

Diagnostic Methods

Specimens (Molecular Tests)

- ◆ Skin vesicle fluid, CSF, nasopharyngeal secretion, bronchial washings, blood, amniocentesis fluid, and urine

Conventional Tests and Problems

- ◆ Viral culture
 - Conventional
 - Virus is difficult to grow in cell culture
 - Viral isolation should be attempted in cases of severe disease, especially in immunocompromised persons



Fig. 20. VZV vesicular eruption. (Courtesy to Bottone, Edward J. *An Atlas of the Clinical Microbiology of Infectious Diseases, Volume 2, Viral, Fungal & Parasitic Agents*. Taylor & Francis, New York, 2006.)

- The best results are obtained from vesicular fluid with lower yield from other sites (nasopharyngeal secretion, blood, urine, bronchial washings, and CSF)
- Diagnosed by observation of CPE induced by virus, which usually occur in 1 week after initial inoculation
- Schell vial assay
 - A centrifugation-enhanced culture technique used to obtain rapid and more sensitive culture results
 - It provides results within 2–3 days
- ◆ Cytology
 - Intranuclear inclusion bodies
 - Multinucleated, molded giant cells
 - Margination of nuclear chromatin
- ◆ Serological studies
 - ELISA—ranges in sensitivity from 86% to 97% and range in specificity from 82 to 99%
 - Latex agglutination—rapid, simple-to-perform assay to detect antibodies to VZV glycoprotein antigen
 - 96% is positive in convalescent-phase serum specimens
 - 61% is positive in persons after vaccination
 - Fluorescent antibody to membrane antigen test
 - It is highly sensitive and is the gold standard for screening for immune status for VZV
 - 100% positive in convalescent-phase serum specimens
 - 77% positive in persons after vaccination
- ◆ Direct fluorescent antibody (DFA)
 - Using fluorescein-labeled monoclonal antibodies specific for either HSV or VZV antigens
 - Results are obtained within several hours
 - Specimen is best collected from the base of a skin lesion, preferably a fresh fluid-filled vesicle
 - The use of DFA may be positive when viral cultures are negative because infected-cell viral proteins persist after cessation of viral replication

Molecular Methods

Conventional PCR

- ◆ Targets VZV *orf 29* gene, and LOD is 500 copies/mL

Real-time PCR—LightCycler (Artus VZV LC PCR Kit)

- ◆ 82-bp VZV genome
- ◆ Analytical sensitivity: 0.8 copy/ μ L
- ◆ Specificity: 100%

Other Real-Time PCR—LightCycler

- ◆ It targets gene 28, DNA polymerase, gene 29, gene 38, or DNA-binding protein
- ◆ It is 91% more sensitive than the shell vial cell culture assay from dermal specimens

Real-Time Quantitative PCR (TaqMan[®]) Technique

- ◆ It targets gene 28, gene 38, or glycoprotein B
- ◆ Assay results range from 10 copies/mL to 1×10^{10} copies/mL
- ◆ It is 53.8% more sensitive than cell culture from dermal specimens

Pitfalls

- ◆ Important to note that PCR assays are not standardized and variations in sample handling and laboratory methods can affect the sensitivity of the assay

Clinical Utility

- ◆ Intrauterine infection of the fetus with VZV virus can be detected by PCR testing of amniocentesis fluid
- ◆ It can be applied on different specimens including mucosa secretion, skin lesion, and so on
- ◆ Diagnosis of encephalitis in immunocompromised patients by detection of VZV in CSF
- ◆ Early initiation of VZV-specific anti-viral therapy may prevent serious morbidity among HIV-infected patients

HUMAN PAPILLOMA VIRUS (HPV)

General Characteristics

- ◆ HPV is a member of the *Papillomaviridae* family that can completely integrate with the DNA of the host cell. Humans are the only known reservoir for HPV
- ◆ Papilloma viruses are non-enveloped viruses of icosahedral symmetry with 72 capsomeres that surround a genome containing double-stranded circular DNA with approximately 8000 bp
- ◆ The expression of viral genes is closely associated with an epithelial localization and linked to the state of

cellular differentiation. Most viral genes are not activated until the infected keratinocyte leaves the basal layer. Production of virus particles can occur only in highly differentiated keratinocytes; therefore, virus production only occurs at the epithelial surface where the cells are ultimately sloughed into the environment

- ◆ Over 100 genotypes of HPV have been identified based on DNA sequence heterology. A specific group, termed high-risk genital HPV types (especially 16, 18, 31, 45, and 58, but also 33, 35, 39, 51, 52, 56, 59, 68, 73, and 82),

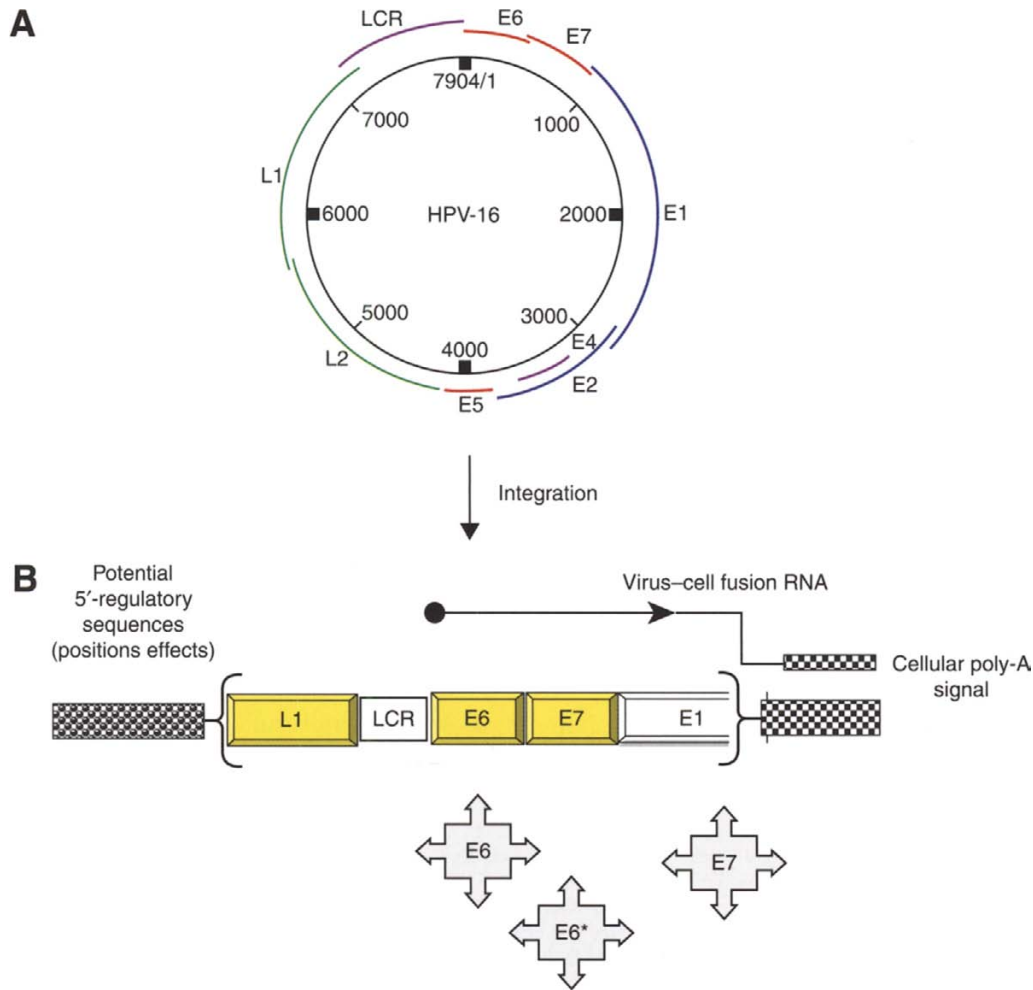

Fig. 21. Adapted from Patrick Finzer, Adriana Aguilar-Lemarroy, and Frank Rosl: the role of HPV oncoproteins E6 and E7 in apoptosis, *Cancer Lett.* 2002;188(1-2):15-24.

are recognized as a necessary factor for the development of cervical cancer

- ◆ The genome HPV virus is circular (**Figure 21**). The genome has eight open reading frames that encode ten proteins. The genes for these are divided into an early region that are expressed in the skin's infected basal cells that have yet to differentiate, and a late region with two genes whose protein products exist only in cells after cell differentiation
- ◆ The E5 (changes the cellular responses to programmed cell death or apoptosis), E6 (binds to tumor suppressor protein, p53), and E7 (binds and inactivates retinoblastoma protein, Rb) proteins are early viral proteins expressed upon infection and cause destabilization of the infected cell and induces replication
- ◆ As the cell differentiates, it migrates upward and induces expression of the E1, E2 and E4 genes; E1 and E2 cause viral replication and E4 destabilizes the cytoskeleton and prevent cellular differentiation

- ◆ In the upper epithelial cell layers the late viral proteins L1 (major capsid protein) and L2 (minor capsid protein) are expressed. They bind the viral DNA and autoassemble, giving rise to the complete virions, ready for a new infection that is released as the keratinocytes desquamate
- ◆ The most common mode of transmission is via contact, i.e., sexual or autoinoculation

Clinical Presentation

- ◆ HPV is by far the most common sexually transmitted disease. An estimated 80% of sexually active adults have been infected with one or more genital HPV strains. The vast majority of infected adults experience transient infectivity and are unaware of the condition; however, they may be able to infect others
- ◆ However, most women infected with high-risk HPV, especially women under 30 years of age, do not develop cervical cancer. Their immune system effectively clears the infection over the course of several months

- ◆ Specific factors that determine which HPV infections persist and develop into squamous intraepithelial lesions currently are unknown. Cigarette smoking, ultraviolet radiation, pregnancy, folate deficiency, and immune suppression have been implicated as possible cofactors
- ◆ Low-risk HPV types (HPV, 6, 11, 42, 43, and 44) produce benign epithelial tumors of the skin and mucous membranes. Infection with certain types of HPV (high risk) can also increase the risk of developing cervical and other cancer types. Conditions associated with HPV:
 - Veruca vulgaris (common wart)—associated with HPV-2, HPV-4, and HPV-40. Highly contagious and can spread to other sites of skin or mucous membranes via autoinoculation
 - Condyloma acuminatum (venereal wart)—associated with HPV-6, HPV-11, HPV-16, and HPV-18 is considered a sexually transmitted disease with lesions occurring in sites of sexual contact or trauma, i.e., mucous membranes of genitalia, perianal region, oral cavity, and larynx
 - Flat warts—most commonly found on the face or forehead, and are most common in children and teens
 - Plantar warts—are found on the soles of the feet
 - Sub-ungual and periungual warts—warts forming under the fingernail (sub-ungual) and around the fingernail or on the cuticle (periungual) are a subtype of the common skin wart. They may be more difficult to cure than warts in other locations
 - Butcher’s warts—caused by HPV-7 and occurs in people handling meat, poultry, and fish
 - Focal epithelial hyperplasia (Heck’s disease)—caused by HPV-13 (and possibly HPV-32) and commonly occurs in Native American and Inuits. A childhood condition characterized by multiple soft, non-tender flat papules and plaques of the oral mucous membrane
 - Laryngeal papillomatosis—frequently recur and may require repetitive surgery when interferes with breathing. Rare cases can progress to laryngeal cancer (HPV-30 and HPV-40)
 - HIV-associated papillomatosis—HPV-7 and immunocompromised states
 - Cervical cancer—history of HPV (high-risk types) infection is strongly associated with development of cervical cancer. However, most HPV infections do not progress to cervical cancer. Because the progression of transforming normal cervical into cancerous cells is a slow process, cancer occurs in people who have been infected with HPV for a long time, usually over a decade. High-risk HPV types 16 and 18 are together responsible for over 70% of cervical cancer cases; type 16 alone causes 41–54% of cervical cancers
 - Other cancers—about 15 strains of HPV (including 16, 18, and 31) can also cause anal, vulvar, head and neck, non-melanoma skin cancers, and (rarely) penile cancer. High-risk types of HPV can cause

intraepithelial neoplasias, or abnormal and pre-cancerous cell growth, in the vulva and cervix, which can progress to cancer

Diagnostic Methods

Specimens

- ◆ Cervical washings/brushings collected in liquid media (i.e., PreservCyt), Digene specimen collection tube (hybrid capture only) or biopsies

Conventional Tests and Problems

- ◆ Viral culture
 - HPV cannot be reliably cultured and is not identified using this technique
- ◆ Cytology
 - Koilocytosis describes the combination of perinuclear clearing (halo) with a pyknotic or shrunken nucleus
- ◆ Serological studies not useful for diagnosis

Molecular Methods

Nucleic Acid Hybridization

- ◆ *In situ* hybridization (INFORM HPV DNA test, Ventana Medical Systems Inc., Tucson, AZ)
 - Use tissue sections, liquid-based cytology specimens, and cervical smears
 - On slide detection of high- and low-risk HPV genotypes
 - 16 probe cocktail for high-risk HPV genotypes 16, 18, 31, 33, 35, 39, 51, 52, 56, 58, and 66
 - Six probe cocktail for low-risk HPV genotypes 6 and 11
- ◆ Digene Hybrid Capture II (Digene Corporation, Gaithersburg, MD)
 - Method utilizes a RNA probe mix for the detection of the L1 gene of HPV. Assay can identify HR HPV types 16, 18, 31, 33, 35, 39, 45, 51, 52, 56, 58, 59, and 68. In addition, a kit detecting low-risk virus (6, 11, 42, 43, and 44) is also available
 - Signal amplification is based on immunocapture of DNA/RNA hybrids that are immobilized on a 96-well microplate, reacted with alkaline phosphatase-conjugated antibodies specific for the RNA:DNA hybrids and detected with a chemiluminescent substrate
 - Can detect 5000 viral copies per sample, or 1 pg of HPV DNA per sample
- ◆ Invader assay (Third Wave Technologies)
 - This method uses isothermal signal amplification to detect 13 HR HPV types utilizing three probe pools based on phylogenetic relatedness. Three probe pools include A5/A6 (51, 56), A7 (18, 39, 45, 59, 68), and A9 pool (16, 31, 33, 35, 52, 58)
 - Invader is an isothermal linear signal amplification using structure-specific oligonucleotide cleavage and has been applied to DNA-based genotyping

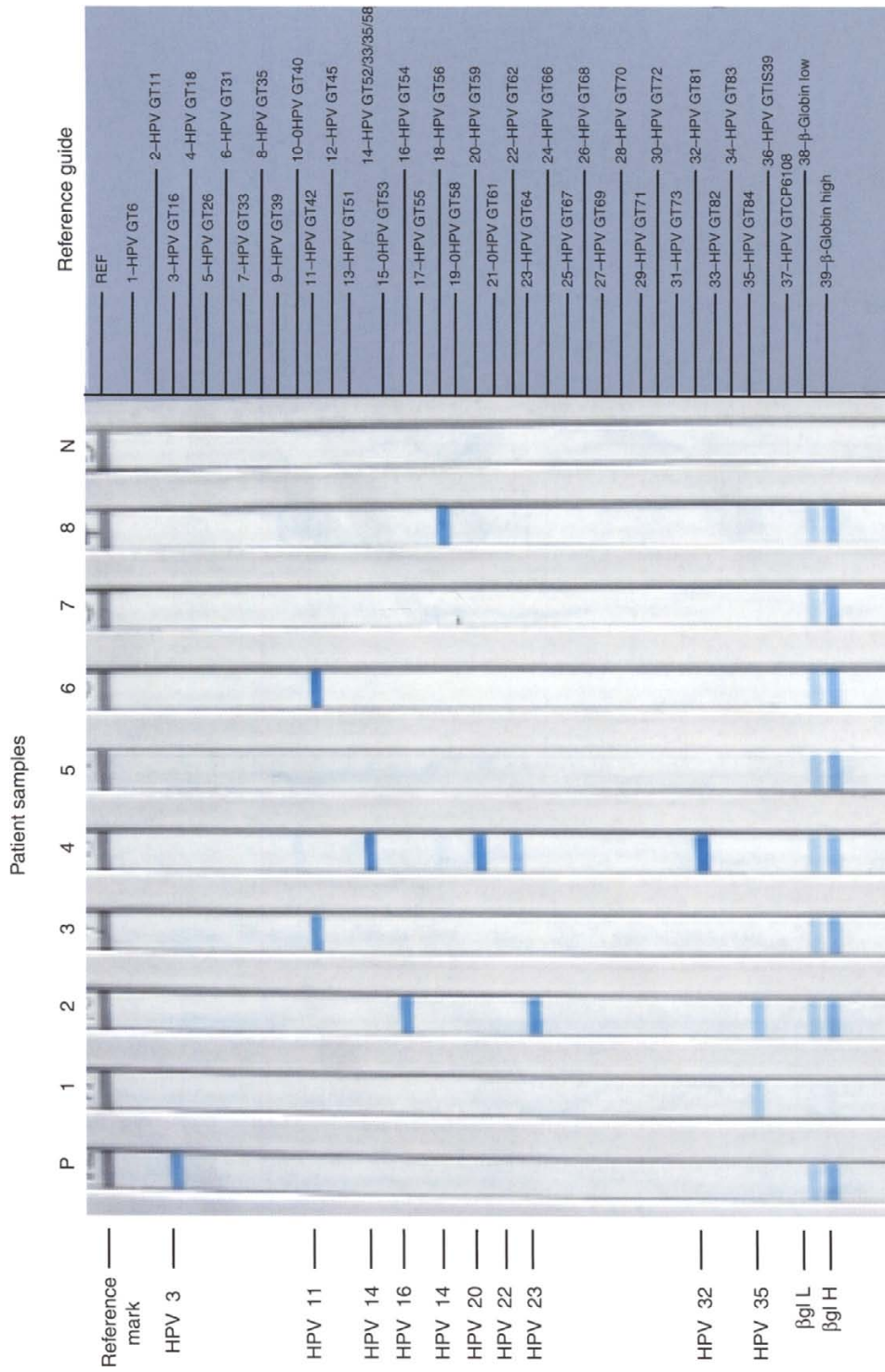

Fig. 22. Roche linear array HPV genotyping assay with reference guide utilized for interpretation. P, positive control; N, negative control; βgL, β-globulin low; βgH, β-globulin high.

Table 8. hc2 High-Risk HPV DNA Test Performance vs Consensus Histology Results (CIN 2–3)

	Age <30	Age 30–39	Age >39
Number of cases	287	233	365
Prevalence of disease (%)	12.2	11.2	2.7
Sensitivity (%)	100 (35/35)	88.46 (23/26)	80 (8/10)
95% Confidence interval	90–100	69.9–97.6	44.4–97.5
Specificity (%)	31.4 (79/252)	66.2% (137/207)	79.15 (281/355)
95% Confidence interval	25.7–37.5	59.3–72.6	74.6–83.3
Negative predictive value (%)	100 (79/79)	97.86 (137/140)	99.29 (281/283)
Positive predictive value (%)	16.83 (35/208)	24.73 (23/93)	9.76 (8/82)

Age-specific characteristics. Kaiser study data (Adapted from Digene package insert)

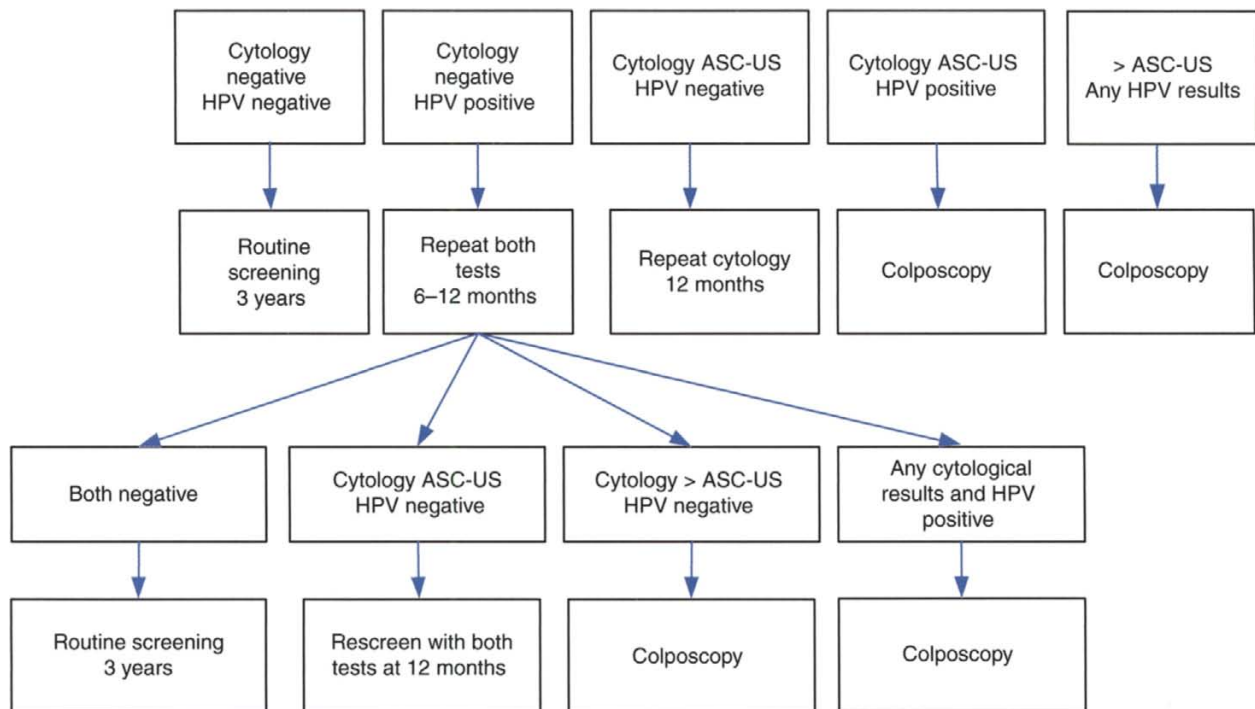

Fig. 23. Proposed management scheme of atypical squamous cells of undetermined significance based on cytology and/or High-Risk HPV DNA test. (Adapted from Wright et. al. HPV testing as adjunct to cytology, *Obstet Gynecol.* 2004;103(2):304–309; (American College of Obstetricians and Gynecologists).

- Assay utilizes an internal control for human α -actin to assure DNA quality and quantity in each reaction

Genotyping

◆ Roche linear array (Figure 22)

- Qualitative test that utilizes amplification of HPV target DNA by PCR and nucleic acid hybridization bases on four major steps:

- Sample preparation
- PCR amplification of target DNA using HPV-specific complementary primers
- Hybridization of the amplified products to oligonucleotide probes
- Colorimetric detection of the probe-bound amplified products

- Uses a pool of biotinylated primers to define a sequence of nucleotides for the L1 region of the HPV genome designed to amplify HPV DNA from 37 HPV genotypes, including 13 high-risk genotypes (16, 18, 31, 33, 35, 39, 45, 51, 52, 56, 58, 59, and 68)
- B-globulin gene is concurrently isolated and ensures adequacy of cellularity, extraction, and amplification for each processed sample

Sensitivity and Specificity

- ◆ Overall, the sensitivity for cytology for detecting high grade squamous intraepithelial lesion (HGSIL) ranges from 50–70% and specificity 86–98%
- ◆ Overall, the sensitivity of HPV DNA test for detecting HGSIL is about 80–98% and specificity 64–95%
- ◆ However, the sensitivity and specificity is influenced by the age and prevalence (**Table 8**)

Pitfalls

- ◆ Digene hybrid capture assay

- Limited sensitivity (1 pg/mL)
- Mixed high- and low-risk probes, cannot distinguish specific HPV types
- It is labor intensive

Clinical Utility

- ◆ To screen patients with atypical squamous cells of undetermined significance. Pap smear results to determine the need for referral to colposcopy. The results of this test are not intended to prevent women from proceeding to colposcopy
- ◆ In women 30 years and older the hc2 high-risk HPV DNA test can be used with Pap smear to adjunctively screen to assess the presence or absence of high-risk HPV types. This information, together with the physician's assessment of cytology history, other risk factors, and professional guidelines, may be used to guide patient management
- ◆ Recently, a new test scheme was proposed (**Figure 23**)

INFLUENZA A, B, AND C

General Characteristics

- ◆ Influenza is part of the *Orthomyxoviridae* family and can be classified into three basic types, influenza A, B, or C (**Table 9**). Each Influenza virus-type is an enveloped single-stranded RNA virus that shares structural and biological similarities but differs antigenically. Type A influenza virus, which causes pandemic is found in a variety of warm-blooded animals. Types A and B are predominantly human pathogens. Type C is found in humans and pigs
- ◆ Influenza viruses have a segmented RNA genome (**Figure 24**). Influenza A and B contain 8 distinct segments and are covered with surface glycoproteins, hemagglutinin (HA), neuraminidase (NA), and matrix 2. Influenza C has seven segments and one surface glycoprotein. The viruses are typed based on these proteins. For example, influenza A (H3N2) expresses HA 3 and NA 2
- ◆ Influenza is a dynamic virus that may evolve in two different ways via antigenic drift and antigenic shift resulting in genetic diversity. Antigenic shift occur when two different strains of influenza viruses combine with antigenically different HA and NA by reassortment of viral RNA segments; this process occurs every 10–40 years. Antigenic drift occurs by random point mutation in viral RNA leading to amino acid substitutions in HA glycoproteins. Influenza type A viruses undergo both antigenic shift and drift; influenza type B viruses undergo antigenic drift
- ◆ Each influenza RNA segment is further encapsidated by nucleoproteins to form ribonucleotide–nucleoprotein complexes surrounded by matrix proteins

- ◆ Influenza virus infections rank as one of the most common infectious diseases in humankind. However, influenza may potentially cause severe epidemics and kills an average of 20,000 individuals in the United States
- ◆ The most common prevailing human influenza A subtypes are H1N1 and H3N2. Each year, the distributed vaccine contains A strains from H1N1 and H3N2, along with an influenza B strain

Table 9. Comparison of Influenza A, B, and C

	Type A	Type B	Type C
Severity of illness	++++	+	+
Animal reservoir	Yes	No	No
Human pandemics	Yes	No	No
Human epidemics	Yes	Yes	No (sporadic)
Antigenic changes	Shift, drift	Drift	Drift
Segmented genome	Yes	Yes	Yes
Amantadine, rimantidine	Sensitive	No effect	No effect
Zanamivir (relenza)	Sensitive	Sensitive	
Surface glycoproteins	2	2	(1)

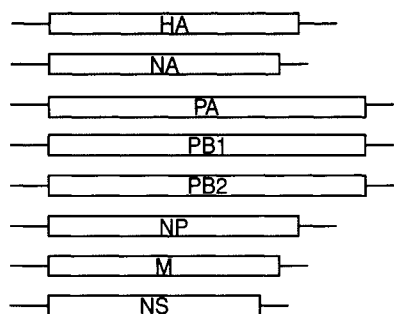

Fig. 24. Influenza virus genome: the virus contains 7-8 single-stranded RNAs (Influenza A and B contains 8 RNAs and influenza C contains 7 RNA). The RNAs cod for 9-11 viral proteins: HA, hemagglutinin; NA, neuraminidase; PA, PB1 and PB2, polymerase complex; NP, nucleoprotein; M, matrix protein; NS, non-structural protein. PCR primers usually target HA and NA consensus region.

- ◆ Influenza virus infection occurs after transmission of respiratory secretions from an infected individual to a person who is immunologically susceptible

Clinical Presentation

- ◆ Although the presentation of influenza virus infection is variable, typical symptoms may include the following: fever, sore throat, myalgia, headache, rhinitis, fatigue, and coughing. Onset of illness may be abrupt
- ◆ Patients with a pre-existing immunity or received vaccination may have mild and less severe symptoms
- ◆ Acute encephalopathy has recently been described to be associated with influenza A virus. Clinical features included altered mental status, coma, seizures, and ataxia
- ◆ The incubation period ranges from 18–72 hours

Diagnostic Methods

Specimens

- ◆ Nasopharyngeal aspirate/swab/washing, tracheal aspirate, or bronchoalveolar lavage
- ◆ Transport:
 - Culture/DFA: 3 mL (minimum 1 mL) of respiratory sample in viral transport media (Microtest M4) or in sterile leak-proof container at 2–8°C
 - Serologic—1 mL (minimum 0.5 mL) serum in a serum separation tube (SST) tube at 2–8°C
- ◆ Unacceptable specimens: dry swabs or wood and calcium alginate swabs that may inactivate the virus for culture. Plasma or hemolyzed, lipemic, icteric, turbid, bacterially contaminated, or heat-inactivated serum are inadequate for serologic testing

Conventional Tests and Problems

- ◆ Viral culture

- The criterion standard for diagnosing influenza A and B is via viral propagation in embryonated hens' eggs or Madin-Darby canine kidney cells
- Laboratory diagnosis of influenza is established once specific CPE is observed or hemadsorption testing findings are positive
- After culture isolation, final identification via immunoassays or IF
- Staining the infected cultured cell lines with fluorescent antibody confirms the diagnosis
- The viral culture process requires 3–10 days to complete
- Primary method for vaccine production
- ◆ Direct IF testing
 - The technique is more rapid (24 hours) to result; it is less sensitive than culture methods
 - This technique can distinguish between influenza A and B
- ◆ Serologic studies
 - Two samples should be collected per person. One sample within the first week (acute) of symptoms and a second sample (convalescent) 2–4 weeks later. If antibody levels increase from the first to the second sample, influenza infection likely occurred
 - Because of the length of time needed for a diagnosis of influenza by serologic testing, other diagnostic testing should be used if a more rapid diagnosis is needed
 - Inability to differentiate between current and previous infection. Cannot be used for rapid diagnosis
- ◆ Rapid testing (**Table 10**)
 - Fastest method of currently available diagnostic tools. Result may be obtained in <30 min
 - However, the technique has a sensitivity of 70–80%

Molecular Methods

RT-PCR (Artus™ Influenza LC RT-PCR Kit, Qiagen Diagnostics)—for research use

- ◆ Marked improvement in sensitivity when compared with viral culture
- ◆ Method utilizes nested RT-PCR method targeting a conserved region of the matrix, and NA genes of influenza A and B
- ◆ Additionally, the TaqMan technology allows for quantitation of viral load
- ◆ Can detect as few as 10 virions/reaction.

Cepheid SmartCycler System—Flu A and B (ASR)

- ◆ It targets a conserved region of the matrix, and NA genes of influenza A and B

Sensitivity and Specificity (**Table 11**)

- ◆ Sensitivity of DFA methodology is dependent upon adequacy of the specimen, i.e., >20 cells. Otherwise,

Table 10. Commercially Available Rapid Point-of-Care Influenza Detection Kits

Commercial name	Assay type	Virus	Specimen type	Sensitivity (%)	Specificity (%)
Directogen Flu A + B (Becton Dickinson)	Membrane filter EIA for NP	A or B	Nasal aspirate, nasopharyngeal swab/wash	72–96 71–89	91–98 90–100
			Nasal or throat swab	77	91–100
			FLU OIA (biostar)	Optical surface EIA for NP	A or B
QuickVue influenza (Quidel)	Lateral-flow strip EIA for NP	A or B	Throat swab	62	79
			Sputum	81	52
			Zstat flu (Zymtex)	NA enzyme activity	A or B
Zstat flu (Zymtex)	NA enzyme activity	A or B	Throat swab	62	99
			Nasal swab	70	92

Adapted from Douglas D. Richman, Richard J. Whitley, and Frederick G. Hayden. Clinical Virol., 2nd ed., ASM press

Table 11. Sensitivity and Specificity of Diagnostic Tests of Influenza

Assay	Sensitivity (%)	Specificity (%)
Baxter Bartels—IF	40 (19–63)	88 (74–96)
Imagen—direct immunofluorescence (DF)	65 (41–85)	92 (79–98)
BD-EIA	75 (51–92)	100 (91–100)
RT-PCR	95 (88–100)	98 (88–100)

specimen may be inadequate for accurate interpretation resulting in false-negative

- ◆ Rapid diagnostic testing is approximately >70% sensitive for detecting influenza and approximately >90% specific. Thus, as many as 30% of samples that would be positive for influenza by viral culture may give a negative rapid test result; some rapid test results may indicate influenza when a person is not infected with influenza

Pitfalls

- ◆ Due to the length of time required to perform viral culture, the assay has poor efficacy as results are obtained much after the patient has left the office or well past the time when drug therapy could be effective
- ◆ Development of PCR-based assays must always consider antigenic drift and random mutations due to viral evolution that may result in false-negatives

Clinical Utility

- ◆ Because of cost, availability, and sensitivity issues, diagnosis of influenza is often based on clinical criteria and presentation
- ◆ RT-PCR and TaqMan assays provide a rapid and specific diagnosis of influenza to allow for early therapeutic intervention and prophylactic treatment in high-risk patients, i.e., geriatric care facility
- ◆ Molecular diagnosis will play a large role in epidemiologic surveillance, vaccine strain selection, and surveillance of emergent novel influenza viruses, i.e., the Hong Kong H5N1 outbreak with sequence analysis

AVIAN INFLUENZA (BIRD) INFLUENZA (FLU) A VIRUSES

General Characteristics

- ◆ Influenza viruses that infect birds are called avian influenza viruses. Only influenza A viruses and subtypes infect birds
- ◆ There are substantial genetic differences between the subtypes that typically infect both people and birds.

Within subtypes of avian influenza A viruses there also are different strains

- ◆ These influenza viruses occur naturally among birds
 - Wild birds world wide carry the viruses in their intestines, but usually do not get sick from them

- However, avian influenza is very contagious among birds and can make some domesticated birds, including chickens, ducks, and turkeys, very sick and kill them
- ◆ There are many different subtypes of type A influenza viruses
 - These subtypes differ because of changes in certain proteins on the surface of the influenza A virus (HA and NA proteins)
 - There are 16 known HA subtypes and nine known NA subtypes of influenza A viruses
 - Many different combinations of HA and NA proteins are possible. Each combination represents a different subtype
 - Avian influenza A H5 and H7 viruses can be distinguished as “low pathogenic” and “high pathogenic” forms on the basis of genetic features of the virus and the severity of the illness they cause in poultry; influenza H9 virus has been identified only in a “low pathogenicity” form
 - Each of these three avian influenza A viruses (H5, H7, and H9) theoretically can be partnered with any one of nine NA surface proteins; thus, there are potentially nine different forms of each subtype (e.g., H5N1, H5N2, H5N3, H5N9)

Clinical Presentation

- ◆ Symptoms of avian influenza in humans
- ◆ Typical influenza-like symptoms (e.g., fever, cough, sore throat, and muscle aches)
- ◆ Eye infections
- ◆ Pneumonia and severe respiratory diseases (such as acute respiratory distress)

- ◆ The avian flu H5N1 virus is resistant to amantadine and rimantadine
- ◆ Two other anti-viral medications, oseltamivir and zanamivir, may work to treat influenza caused by H5N1 virus

Diagnostic Methods

Culture

- ◆ See Influenza A, B, and C section

Serologic Test

- ◆ See Influenza A, B, and C section

Molecular Test

- ◆ Real-time reverse transcription—(RT-PCR) (Centers for Disease Control [CDC])
- ◆ Specimens: nasal swab, bronchoalveolar lavage (BAL), stool, and culture
- ◆ FDA-cleared assay for the Influenza A/H5 (Asian lineage)
- ◆ Primer and probe set developed at CDC, is designed to detect highly pathogenic influenza A/H5 viruses from the Asian lineage
- ◆ Inactivated virus as a source of positive RNA control
- ◆ The test is limited to laboratories designated by the Laboratory Response Network

Limitation

- ◆ Due to the limitation of the assay, negative results do not preclude influenza virus infection and should not be used as the sole basis for treatment or other patient management decisions

ADENOVIRUS

General Characteristics

- ◆ Adenovirus is ubiquitous in humans and is endemic
- ◆ Adenoviruses are medium-sized (90–100 nm), non-enveloped icosahedral viruses containing dsDNA (**Figure 25**)
- ◆ 49 immunologically distinct types (six sub-genera: A–F) can cause human infections
- ◆ Adenovirus transcription can be defined as a two-phase event, early and late, occurring before and after DNA replication
- ◆ Early transcription is accompanied by a complex series of splicing events, with four early “cassettes” of gene termed *E1*, *E2*, *E3*, and *E4*. Early genes facilitate DNA replication and result in the transcription and translation of the late genes (**Figure 26**)
- ◆ Adenovirus produces cytolysis in different tissues and induces host inflammatory responses and cytokine production

- ◆ Transmission of adenovirus is via direct contact, the fecal-oral route, and occasionally waterborne transmission and occurs usually during infancy or adolescence

Clinical Presentation

- ◆ Most adults have measurable titers of anti-adenovirus antibodies, implying prior infection. However, most infections are asymptomatic
- ◆ Some adenovirus types can establish persistent sub-clinical infections in tonsils, adenoids, and intestines of infected hosts with viral shedding occurring for as long as several months to years
- ◆ Adenovirus may infect multiple organ systems and is recognized as the etiologic agent of a variety of diverse syndromes: acute respiratory disease, pharyngo-conjunctival fever, epidemic keratoconjunctivitis, acute hemorrhagic cystitis, gastroenteritis, and adenoviral infections in immunocompromised hosts

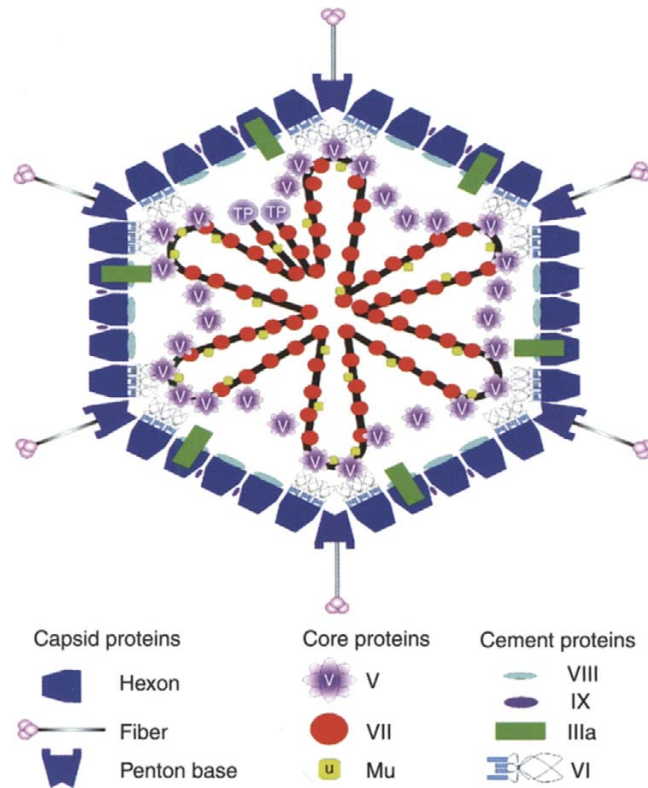

Fig. 25. Structure of adenovirus. (Adapted from W. C. Russell: Update on adenovirus and its vectors, *J. Gen. Virol.* 2000;81: 2573–2604.)

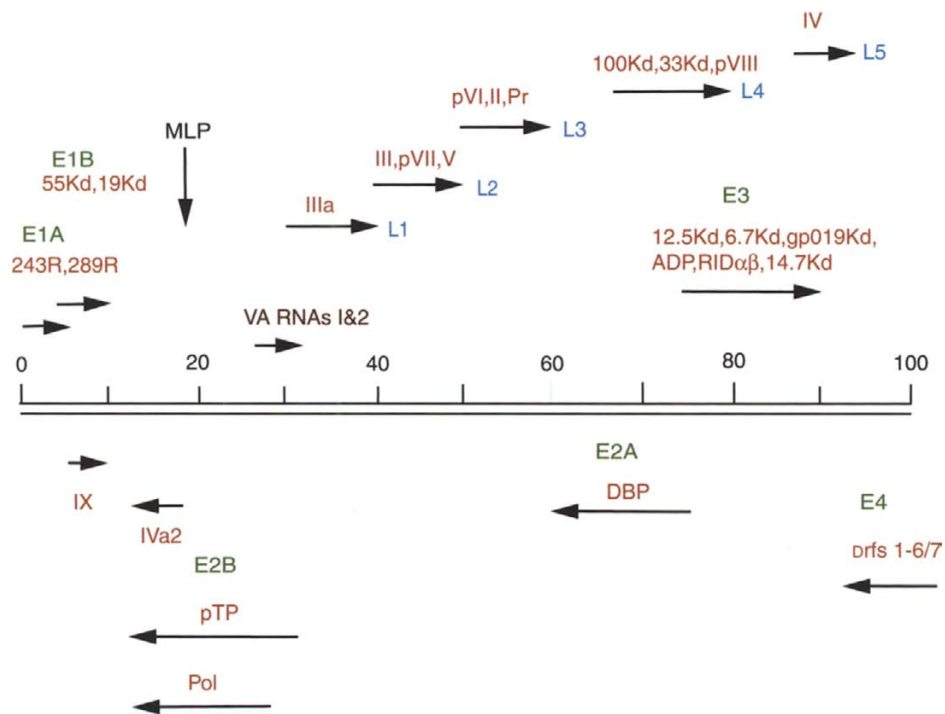

Fig. 26. Transcription of the adenovirus genome. The early transcripts are outlined in green, the late in blue. Arrows indicate the direction of transcription. The gene locations of the VA RNAs (non-translated RNAs) are denoted in brown. MLP, major late promoter. (Adapted from W. C. Russell: Update on adenovirus and its vectors, *J. Gen. Virol.* 2000;81:2573–2604.)

Diagnostic Methods

Specimens (Molecular Tests)

- ◆ Respiratory, stool, and blood

Conventional Tests and Problems

- ◆ Viral culture
 - Many adenovirus serotypes can be isolated in cell culture lines commonly used in diagnostic virology laboratories; however, others fail to grow. Primary human embryonic kidney cells support growth of many fastidious adenovirus serotypes, but the additional cost may be prohibitive in some settings. Adeno-associated virus has also been known to contaminate this cell line. Other cell lines may not support the growth of ocular strains well, may be less sensitive, or may not be maintainable to support slower-growing strains
- ◆ Serologic studies
 - Seroreactivity to adenovirus is common. Positive adenovirus titers occur in 50% of individuals >4 years old
 - Serology is less useful in the acute clinical setting
 - For a serologic diagnosis, serum should be obtained as early as possible in the clinical course, followed by a second titer 2–4 weeks later. A fourfold rise in acute titers to convalescent titers is diagnostic
- ◆ IF
 - Indirect IF assays may be used for direct examination of tissue. It uses a mouse antibody against an adenovirus group-specific *hexon* antigen

Molecular Methods

Polymerase Chain Reaction

- ◆ Marked improvement in sensitivity when compared with viral culture
- ◆ Additionally, the TaqMan technology allows for quantitation of viral load and targets *hexon* gene

Real-Time PCR

- ◆ Real-time-LightCycler, targets *hexon* gene
- ◆ Real-time-SmartCycler, targets *hexon* gene
- ◆ Sensitivity was demonstrated to <10 copies of viral genome per reaction and quantitative linearity was demonstrated from 10 to 10⁸ copies of viral DNA
- ◆ Most of real-time quantitative PCR are designed to detect adenovirus DNA from all major subgroups of the virus

Pitfalls

- ◆ Development of PCR-based assays must always consider antigenic drift and random mutations due to viral evolution that may result in false-negatives
- ◆ Important to note that PCR assays are not standardized and variations in sample handling and laboratory methods can affect the sensitivity of the assay

Clinical Utility

- ◆ PCR and TaqMan assays provide a rapid and specific diagnosis of adenovirus to allow for early therapeutic intervention and prophylactic treatment in high-risk patients, i.e., geriatric care facility and immunocompromised patients
- ◆ Detection of high viral load in blood and monitoring of viral load during treatment can correlate with disseminated adenovirus disease in immunosuppressed patients

RESPIRATORY SYNCYTIAL VIRUS (RSV)

General Characteristics

- ◆ RSV is a negative-sense, enveloped RNA virus. The virion is variable in shape and size (120–300 nm), is unstable in the environment (surviving only a few hours on environmental surfaces), and is readily inactivated with soap and water and disinfectants
- ◆ RSV is a labile paramyxovirus that produces a characteristic fusion of human cells (syncytial effect) in tissue culture
- ◆ RSV is a single-stranded enveloped RNA virus
- ◆ RSV has two heterotypic strains of viruses that are antigenically distinct, and are classified as subgroups A and B

- ◆ The major difference between these subgroups is the antigenic properties of the G surface glycoprotein
- ◆ Transmission is from aerosolized respiratory droplets via close contact with infected persons or contact with contaminated surfaces
- ◆ Most prevalent in infants aged 2–6 months, but children of any age with underlying cardiac or pulmonary disease or who are immunocompromised are at risk for serious complications from RSV infection

Clinical Presentation

- ◆ RSV infections typically occur in temperate climates during late fall through early spring

- ◆ Two subtypes have been identified. Subtype A involves a severe clinical presentation and predominates in most outbreaks. Subtype B predominates in most asymptomatic strains of the virus that the majority of the population experiences
- ◆ RSV bronchiolitis presents with a 2–3-day “pro-dromal” phase, which resembles a common viral upper respiratory tract infection. Additional symptoms include rhinorrhea, wheezing, coughing, low-grade fever, and pneumonia. Circumoral and nailbed cyanosis may occur in severely affected infants
- ◆ In the majority of patients with RSV bronchiolitis, symptoms resolve within 5–7 days

Diagnostic Methods

Specimens

- ◆ Respiratory swabs and bronchoalveolar lavage

Conventional Tests and Problems

- ◆ Viral culture
 - Inoculation in primary monkey kidney cells, human hepatoma cells, MRC-5 cells, and HEp-2 cells and assessed for CPE
 - Decreased sensitivity in adults from reduced viral shedding during acute infections as compared with adolescents
- ◆ Rapid antigen detection
 - Direct and indirect immunofluorescence (IF) methods
 - Ability to perform direct screening with low cost
 - Sensitivity between 80 and 90% and the specificity is at least 94%
 - Incorrect and indeterminate results may occur for specimens with few epithelial cells or when non-specific antibody reagents are used
 - ELISA (BD Directigen™ RSV)
 - ELISA assays do not require expensive laboratory equipment, take only 15–20 minutes, and are inexpensive compared with cell culture

- Its advantages include absence of evaluation of the quality of the clinical sample and potential false-positive results when samples with thick mucus or blood are tested
- Antibody assays
 - Acute- and convalescent-phase sera are required for the serologic diagnosis of RSV
 - A fourfold increase in antibody titer or the appearance of specific IgM antibody is required for serologic confirmation of infection
 - It includes complement fixation antibody titers, ELISA, neutralization to specific A and B subtypes, and indirect IF

Molecular Methods

- ◆ NASBA-beacon
 - NucliSens EasyQ RSV A + B assay (bioMérieux, Durham, NC)
 - Real-time PCR assay-based assay utilizing NASBA technology containing internal control and specific molecular beacon mix targeting fusion protein of RSV
 - LOD is 22 input copies of RSV
 - Improved time to result, <4 hours
- ◆ Cepheid SmartCycler system—RSV (ASR)

Sensitivity and Specificity

- ◆ Improved sensitivity and specificity when compared with conventional tests, particularly in the adult population
- ◆ No cross-reactivity was shown for PIV 1-3, influenza A and B, measles, adenovirus type 1 and 5, hMPV A1, A2 and B1, B2, indicating that the assay is specific for RSV

Pitfalls

- ◆ Cannot distinguish between RSV A and RSV B

Clinical Utility

- ◆ Ease of assay, rapid turnaround time, and improved sensitivity has enhanced clinical utility in early detection of respiratory illness

SEVERE ACUTE RESPIRATORY SYNDROME (SARS)

General Characteristics

- ◆ SARS is a recently identified respiratory illness that first infected individuals in parts of Asia, North America, and Europe in late 2002 and early 2003
- ◆ The SARS-associated coronavirus belongs to the *Coronaviridae* family, a family of large, enveloped

positive-stranded RNA viruses. It is the first example of a coronavirus causing serious disease in humans

- ◆ The SARS-coronavirus (SARS-CoV) genome is 29,272 nucleotides in length with 41% being G/C residues
- ◆ SARS is spread mainly through contact with infected saliva or droplets from coughing. Vertical transmission from mother to infant does not appear to occur

Clinical Presentation

- ◆ The SARS virus produces an atypical pneumonia that often leads to respiratory failure, with pulmonary edema and hyaline membrane formation similar to that seen with adult respiratory distress syndrome
- ◆ During the early phase of the disease, fever $>38^{\circ}\text{C}$ is the hallmark symptom. This finding is often associated by myalgia, rigors, and other flu-like symptoms
- ◆ During the second week, patients develop a dry, non-productive cough, shortness of breath, and lung infiltrates with rapid progression to respiratory distress
- ◆ The cause of death is respiratory failure, with the best predictor of mortality being old age
- ◆ Except for ventilation, no effective treatment is currently available

Diagnostic Methods

Specimens

- ◆ Respiratory sample: nasal wash, nasopharyngeal swab, BAL, bronchial wash, or sputum
- ◆ Transport: 1 mL (minimum volume 0.5mL for adults and pediatrics) respiratory sample in viral transport media (Microtest M4) or in sterile leak-proof container at $2-8^{\circ}\text{C}$
- ◆ Unacceptable conditions: dry swabs are not acceptable. Respiratory aspirates collected in containers with tubing as samples tend to leak, compromising the specimen

Conventional Tests and Problems

- ◆ Viral culture
 - Requires biological safety level (BSL)-3 facility
 - Difficulty in culturing the virus from infected individual late in the outbreak during late stages of illness due to possible genetic drift of virus
- ◆ Serologic studies
 - Utility of serologic testing is poor due to late seroconversion of infected patients, i.e., 2–4 weeks

Molecular Methods

Reverse Transcriptase-PCR

- ◆ Multiple RT-PCR assays have been developed to detect SARS RNA in clinical specimens utilizing nested, non-nested, one-step or two-step conventional, or real-time TaqMan assays
- ◆ PCR primers and probe target various regions: polymerase (*pol*) 1b region of 5' replicase, nucleocapsid (*nuc*) genes, and the 3' non-coding region of the genome
- ◆ LightCycler SARS-CoV Quantitation kit (Roche Diagnostics Corporation) for use with the LightCycler instrument

- Ready-to-use, which amplifies a 180-bp target sequence of the replicase 1AB/polymerase gene of SARS CoV
- ◆ RealArt HPA-Coronavirus RT PCR Kits (Artus) for use with the LightCycler instrument, the ABI Prism 7000, 7700, and 7900H instruments
 - Amplifies an 80-bp region of the SARS-CoV genome
- ◆ EraGen Biosciences MultiCode-RTx (Eragen Biosciences, Madison, WI) (research only)
 - EraGen's platform increases size of the genetic "alphabet" from the two DNA base pairs to six pairs with the development of eight new synthetic bases
 - It is a new, multiplexed real-time PCR platform
 - Only standard PCR primers need to be designed. Since reporters are placed directly onto the primers and not on probes
 - It targets nucleocapsid (*nuc*) or polymerase (*pol*) gene

Sensitivity and Specificity

- ◆ Sensitivity of commercial assays ranged from 36% to 80%; and specificity ranged from 80% to 100%
- ◆ The absolute sensitivity of the RT-PCR assays ranged from 10 to 100 genome equivalents per reaction

Pitfalls

- ◆ When present, SARS antibodies can be detected in serum at any point during the course of the disease. However, most patients do not seroconvert until after the second week, highlighting the importance of an RT-PCR assay for early diagnosis of the virus
- ◆ Positive results must be confirmed by repeat testing using an aliquot of the original specimen and/or another laboratory before reporting. Alternatively, testing of a second gene region may be helpful. Furthermore, testing of one sample from a single source does not rule out the presence of SARS-associated coronavirus
- ◆ A negative result does not rule out SARS as the presence of PCR inhibitors in the patient specimen, poor RNA quality, or nucleic acid concentrations below the LOD of the assay may occur

Clinical Utility

- ◆ During the first week, serum and plasma are preferred for RT-PCR. Between 1–3 weeks, these sample types are less effective; stool and respiratory samples are the preferred types. After 3 weeks, stool is the preferred sample type for RT-PCR. Viral load in the upper respiratory tract and feces is low during the first 4 days of infections and peaks at approximately the 10th day of illness
- ◆ During the 10th–15th day of illness, high viral loads are independent predictors of poor clinical outcomes

ENTEROVIRUS

General Characteristics

- ◆ Enteroviruses represent one of the most common human viruses, affecting an estimate 50 million individuals in the United States and potentially 1 billion world wide. Enterovirus infections most commonly occur in temperate zones during the summer and early fall
- ◆ Enteroviruses, a diverse group of small, non-enveloped RNA viruses that are transmitted by the fecal-oral route
- ◆ Enteroviruses comprise a group of human viruses that includes polioviruses, echoviruses, coxsackie A viruses, coxsackie B viruses, and various enterovirus subtypes. Human viruses are divided among five species based on molecular data into: poliovirus, HEV-A, HEV-b, HEV-C, and HEV-D
- ◆ Although enteroviruses undergo rapid replication in the gastrointestinal tract they rarely cause significant gastrointestinal disease. Instead, they travel via the bloodstream to target organs where they further replicate and induce pathologic alteration

Clinical Presentation

- ◆ Most infections are sub-clinical, although may cause a variety of acute and chronic diseases
 - Acute: mild upper respiratory illness (common cold), febrile rash (hand, foot, and mouth disease and herpangina), aseptic meningitis, pleurodynia, encephalitis, acute flaccid paralysis, and neonatal sepsis-like disease
 - Chronic: myocarditis, cardiomyopathy, type 1 diabetes mellitus, and neuromuscular disease

Diagnostic Methods

Specimens

- ◆ Nasal/throat swabs, BAL, serum, plasma, CSF, and feces samples transported in viral transport media, were either transported directly to the laboratory or were stored at 4°C for a maximum of 24

Conventional Tests and Problems

- ◆ Viral culture
 - Gold standard to detect enterovirus
 - Time-consuming methods and insensitive methods, relying on the presence of viable virus
 - Inability to fully characterize some enterovirus strains associated with late inadequate collection, handling and processing of samples, or because of intrinsic insensitivity to cell lines used
- ◆ Serology
 - Serotype is usually irrelevant to individual management
 - The absence of a widely shared antigen has hampered the development of immunoassays for the enterovirus

- Reports of monoclonal antibodies that cross-react with multiple enterovirus serotypes are promising, but further testing is required to determine the clinical relevance of those observations

Molecular Methods (Figure 27)

- ◆ Real-time RT-PCR—ABI Prism (Applied Biosystems, Foster City, CA)
 - Improved speed and accuracy using TaqMan assay platform
 - Targets conserve sequences of the 5' NTR and VP 1 and 2 (capsid protein). The 5' NTR is the most highly conserved region and is involved in viral protein translation
 - An enterovirus real-time TaqMan PCR analysis of serum or plasma may be a good alternative for the enterovirus culture of feces, particularly in neonates with sepsis

Real-Time—LightCycler-PCR (Home Brew)

- ◆ Targets conserve sequences of the 5' untranslated region (NTR)

Cepheid SmartCycler System

- ◆ It detects a 115-bp region of the 5' UTR

Nucleic Acid Sequence-Based Assay

- ◆ NASBA-electrochemiluminescence (ECL) and NASBA-beacon are not significantly different in sensitivity and specificity
 - Targets conserve sequences of the 5' NTR
- ◆ NASBA-ECL
 - Nuclisens Basic Kit (Organon Teknika, Durham, NC has proved of equal or greater sensitivity for detection of enteroviruses
 - In the Nuclisens Basic Kit, amplified RNA products are detected by hybridization using ECL-labeled probes, a highly sensitive methodology
- ◆ NASBA-beacon
 - Nuclisens EasyQ Enterovirus Test (bioMerieux), which utilizes real-time molecular beacons as probes (NASBA-beacon)
 - Real-time RT-PCR using TaqMan to shorten both technical hands-on time and time to result

EV Consensus (Argene Biosoft)

- ◆ For research use only in the United States
 - One-step RT-PCR of all enterovirus serotypes in one single reaction tube
 - Amplified region is in the 5' non-coding region of the genome
 - Detection is performed with a biotinylated enterovirus generic probe

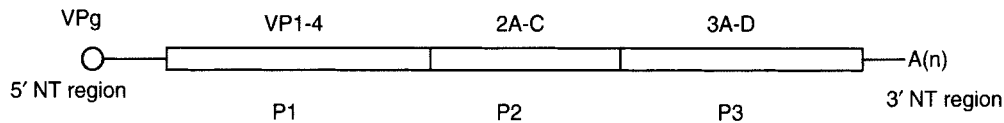

Fig.27. Enterovirus genome: 7450 nucleotide long single-stranded RNA virus with a 5' NT region of 743 NT, a 6625-coding region and 3' polyA region (VP—viral protein, P—polypeptide, NT—non-translational region). PCR primers usually design to target to 5' NT region.

Sensitivity and Specificity

- ◆ NASBA-ECL and NASBA-beacon were similar in sensitivity, (100%) and (94.5%), respectively
- ◆ RT-PCR (sensitivity 97%), while culture (sensitivity 54.5%)
- ◆ Real-time RT-PCR sensitivity is 100% and the specificity is 96.2%

Pitfalls

- ◆ Parechoviruses may cause similar clinical illnesses, but are not detected by enterovirus testing
- ◆ Poor handling of CSF or CSF collected during late infection can yield false-negative results

- ◆ Enteroviruses can be shed in high titers in stool for prolonged periods. Therefore, a positive result in stool alone may not correlate with current disease

Clinical Utility

- ◆ Enteroviral meningitis is common in the United States and leads to a large number of hospitalizations per year due to an inability to distinguish from bacterial meningitis. Therefore, enterovirus differentiation from bacterial illness can significantly reduce hospitalizations, antimicrobial use, and diagnostic testing
- ◆ Rarely, dual infections (enteroviral and bacterial) can occur. Therefore, a positive enterovirus result with clinical features incompatible with benign viral meningitis should not lead to discontinuation of antibiotics

JC/BK VIRUS

General Characteristics

- ◆ The BK (BKV) and JC viruses (JCV) are small, non-enveloped, and closed circular dsDNA virus and belong to human polyomaviruses, members of the *Papovaviridae* family
- ◆ They were first isolated in 1971 and named JC and BK after the initials of the patients in which they were first discovered. JCV was isolated from the brain tissue of a patient with progressive multi-focal leukoencephalopathy (PML); BKV was isolated from the urine of a renal transplant patient who developed ureteral stenosis post-operatively
- ◆ BKV and JCV share 75% homology at the level of nucleotide sequence. Each is 70% homologous to SV40
- ◆ The two are not cross-reactive serologically and serologic tests for antibodies are able to distinguish between BKV and JCV
- ◆ >70% of the adult population has antibodies to BKV and JCV, with primary infections typically occurring in childhood
- ◆ After an initial infection, polyomaviruses establish latency in various tissues. The primary sites of latency are uroepithelial cells for BKV and B-lymphocytes and renal tissue for JCV. Additional sites of latency for both viruses include the ureters, brain, and spleen

Clinical Presentation

- ◆ In immunocompetent individuals, primary BKV infections usually cause a mild respiratory illness, and rarely, cystitis, whereas primary JCV infections are typically asymptomatic
- ◆ Reactivation of latent as well as primary BKV and JCV infections may occur in immunocompromised individuals, i.e., organ transplantation, AIDS, and leukemia. BKV infections can lead to interstitial nephritis, tubulitis, hemorrhagic cystitis, and kidney allograft rejection
- ◆ JCV is responsible for progressive PML, a fatal demyelinating disease of the CNS seen in up to 70% of AIDS patients

Diagnostic Methods

Specimens

- ◆ Urine, plasma, CSF, and tissue biopsy

Conventional Tests and Problems

- ◆ *In situ* nucleic acid hybridization or immunocytochemistry
- ◆ Viral culture

- JCV is difficult to culture
 - The most sensitive cell type for JCV is primary human fetal glial cells, which is not an easy reagent to acquire
 - BKV will grow in common cell lines, such as human diploid fibroblasts, but several days and weeks are required before CPE is evident
- ◆ Serologic studies
- Hemagglutination-inhibition or ELISA methods can measure titers of antibodies to JCV and BKV
 - Serological tests of blood and CSF for anti-JCV and BKV antibodies are not useful in the diagnosis of PML and immunosuppressed individuals because antibodies to JCV and BKV are common and many patients with PML or immunosuppressed patients fail to develop a significant rise in anti-viral antibody titers in serum or CSF

Molecular Methods (Figure 28)

PCR, Quantitative

- ◆ JC/BK Consensus, Argene Biosoft (Unites States: for research use only)—primers/probe product is designed to amplify JCV/BKV using 5' nuclease real-time assay. The targeted sequence corresponds to a fragment of 197/198 bp located in the gene of large T antigen
- ◆ Real-time TaqMan PCR and LightCycler (home-brew)—targets highly conserved sequence of JCV/BKV genomes (VP2 gene)

Sensitivity and Specificity

- ◆ Analytical specificity: no cross-reactivity with HSV family viruses, simian virus, adenovirus, and HIV. Absolute sensitivity: 10 JCV/BKV detection
- ◆ PCR have been able to detect JCV in CSF from 80 to 90% of PML patients
- ◆ The specificity of diagnosis is influenced by the choice of primers and extraction methods but can approach 100%

Pitfalls

- ◆ Sequence variation of polyomavirus genome and within various JC/BK subtypes that may cause difficulty in primer and probe design

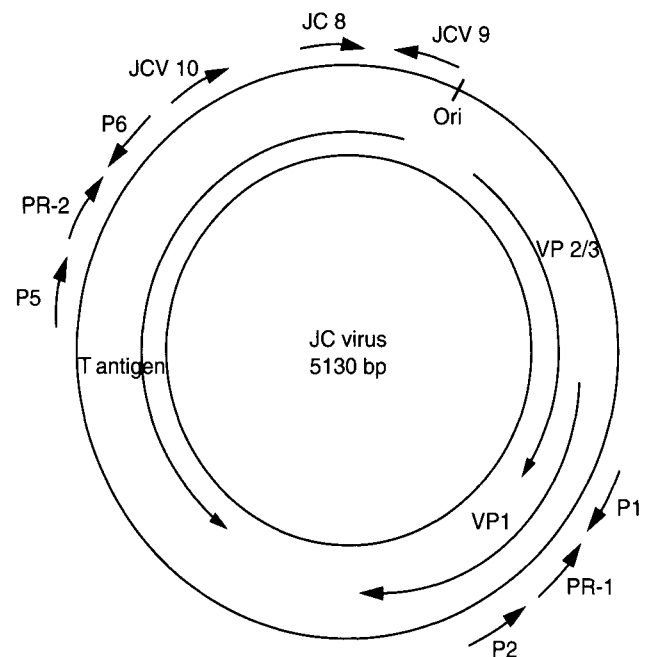

Fig. 28. JCV genome structure.

- ◆ Competition between JCV and BKV due to sensitivity may lead to false-negative PCR result

Clinical Utility

- ◆ Detection of the virus by PCR may be indicative of an active infection. Therefore, the identification of viral DNA may warrant the institution of anti-viral therapies and/or a decrease of immunosuppressive therapies
- ◆ Determination of viral DNA presence or concentration in transplant patients is useful in establishing the cause of allograft rejection. Viral load may also be useful in immunocompromised patients
- ◆ BKV nephropathy is associated with BK viremia of >5000 copies/mL (plasma) and BK viremia >10⁷ copies/mL and is seen in approximately 8% of kidney transplant recipients
- ◆ Though latency is typically associated with the absence of viremia, low levels (<2000 copies/mL plasma) are seen in some asymptomatic individuals

SUGGESTED READING

- Alejo E. Resistance of human cytomegalovirus to antiviral drugs. *Clin Microbiol Rev.* 1999;12:286–297.
- Ando Y, Terao K, Narita M, et al. Quantitative analyses of cytomegalovirus genome in aqueous humor of patients with cytomegalovirus retinitis. *Jpn. J. Ophthalmol.* 2002;46:254–260.
- Anzola M, Burgos JJ. Hepatocellular carcinoma: molecular interactions between hepatitis C virus and p53 in hepatocarcinogenesis. *Expert Rev Mol Med.* 2003;5:19.

- Boeckh M, Boivin G. Quantitation of cytomegalovirus: methodologic aspects and clinical applications. *Clin Microbiol Rev.* 1998;11:533–554.
- Bowen EF, Sabin CA, Wilson P, et al. Cytomegalovirus (CMV) viremia detected by polymerase chain reaction identifies a group of HIV-positive patients at high risk of CMV disease. *AIDS.* 1997;11:889–893.
- Cope AV, Sabin C, Burroughs A, et al. Interrelationships among quantity of human cytomegalovirus (HCMV) DNA in blood, donor-recipient serostatus, and administration of methylprednisolone as risk factors for

- HCMV disease following liver transplantation. *J. Infect. Dis.* 1997;176:1484–1490.
- Cockerill FR, Smith TF.** Response of the clinical microbiology laboratory to emerging (new) and reemerging infectious diseases. *J Clin Microbiol.* 2004;42:2359–2365.
- Comanor L, Hendricks D.** Hepatitis C virus RNA tests: performance attributes and their impact on clinical utility. *Expert Rev Mol Diagn.* 2003;3:689–701.
- Cope AV, Sweny P, Sabin C, et al.** Quantity of cytomegalovirus viremia is a major risk factor for cytomegalovirus disease after renal transplantation. *J. Med. Virol.* 1997;52:200–205.
- Ellermann-Eriksen S.** Macrophages and cytokines in the early defense against herpes simplex virus. *Virology.* 2005;2:1–30.
- Espy M, Uhl JR, Sloan LM, et al.** Real-Time PCR in clinical microbiology: applications for routine laboratory testing. *Clin Microbiol Rev.* 2006;19:165–256.
- Gault E, Michel Y, Dehée A, Belabani C, et al.** Quantification of human cytomegalovirus DNA by real-time PCR. *J. Clin. Microbiol.* 2001;39:772–775.
- Gor D, Sabin C, Prentice HG, et al.** Longitudinal fluctuation in cytomegalovirus load in bone marrow transplant patients: relationship between peak virus load, donor/recipient serostatus, acute GVHD and CMV disease. *Bone Marrow Transplant.* 1998;21:597–605.
- Kearns AM, Guiver M, James V, et al.** Development and evaluation of a real-time quantitative PCR for the detection of human cytomegalovirus. *J. Virol. Methods.* 2001;95:121–131.
- Kearns AM, Turner AJ, Eltringham GJ, et al.** Rapid detection and quantification of CMV DNA in urine using LightCycler-based real-time PCR. *J. Clin. Virol.* 2002;24:131–134.
- Kühn JE, Wendland T, Schäfer P, et al.** Monitoring of renal allograft recipients by quantitation of human cytomegalovirus genomes in peripheral blood leukocytes. *J. Med. Virol.* 1994;44:398–405.
- Landry ML, Garner R, Ferguson D.** Comparison of the NucliSens basic kit (nucleic acid sequence-based amplification) and the Argene Biosoft enterovirus consensus reverse transcription-PCR assays for rapid detection of enterovirus RNA in clinical specimens. *J Clin Microbiol.* 2003;41:5006–5010.
- Landry ML, Garner R, Ferguson D.** Real-Time nucleic acid sequence-based amplification using molecular beacons for detection of enterovirus RNA in clinical specimens. *J Clin Microbiol.* 2005;43:3136–3139.
- Machida U, Kami M, Fukui T, et al.** Real-time automated PCR for early diagnosis and monitoring of cytomegalovirus infection after bone marrow transplantation. *J. Clin. Microbiol.* 2000;38:2536–2542.
- Mahony JB, Richardson S.** Molecular diagnosis of severe acute respiratory syndrome. *J Molec Diagn.* 2005;7:551–559.
- Moore C, Valappil M, Corden S, et al.** Enhanced clinical utility of the NucliSens EasyQ RSV A+B Assay for rapid detection of respiratory syntenial virus in clinical samples. *Eur J Clin Microbiol Infect Dis.* 2006;25:167–174.
- Moret H, Brodard V, Barranger C, et al.** New commercially available PCR and microplate hybridization assay for detection and differentiation of human polyomaviruses JC and BK in cerebrospinal fluid, serum, and urine samples. *J Clin Microbiol.* 2006;44:1305–1309.
- Murray PG, Young LS.** Epstein-Barr virus infection: basis of malignancy and potential for therapy. *Expert Rev Molec Med.* 2001;3:1–20.
- Nitsche A, Steuer N, Schmidt CA, et al.** Detection of human cytomegalovirus DNA by real-time quantitative PCR. *J. Clin. Microbiol.* 2000;38:2734–2737.
- Neville BW, Dam DD, Allen CM, Bouquot JE.** Oral and Maxillofacial Pathology. Philadelphia, PA: WB Saunders Company; 1995.
- Oberste MS, Pallansch MA.** Enterovirus molecular detection and typing. *Rev Med Microbiol.* 2005;16:163–171.
- Podzorski RP.** Molecular testing in the diagnosis and management of hepatitis C virus infection. *Arch Path Lab Med.* 2002;126:285–290.
- Rasmussen L, Zipeto D, Wolitz RA, et al.** Risk for retinitis in patients with AIDS can be assessed by quantitation of threshold levels of cytomegalovirus DNA burden in blood. *J. Infect. Dis.* 1997;176:1146–1155.
- Russell WC.** Update on adenovirus and its vectors. *J Gen Virol.* 2000;81:2573–2604.
- Shinkai M, Bozzette SA, Powderly W, et al.** Utility of urine and leukocyte cultures and plasma DNA polymerase chain reaction for identification of AIDS patients at risk for developing human cytomegalovirus disease. *J. Infect. Dis.* 1997;175:302–308.
- Spector SA, Wong R, Hsia K, et al.** Plasma cytomegalovirus (CMV) DNA load predicts CMV disease and survival in AIDS patients. *J. Clin. Invest.* 1998;101:497–502.
- Taubenberger JK, Layne SP.** Diagnosis of influenza virus: coming to grips with the molecular era. *Mol Diagn.* 2001;6: 291–305.
- Tanaka N, Kimura H, Iida K, et al.** Quantitative analysis of cytomegalovirus load using a real-time PCR assay. *J. Med. Virol.* 2000;60:455–462.
- Toyoda M, Carlos JB, Galera OA, et al.** Correlation of cytomegalovirus DNA levels with response to antiviral therapy in cardiac and renal allograft recipients. *Transplantation* 1997;63:957–963.
- Whiley DM, Mackay IM, Sloots TP.** Detection and differentiation of human polyomaviruses JC and BK by LightCycler PCR. *J Clin Microbiol.* 2001;39:4357–4361.
- Zaia JA, Gallez-Hawkins GM, Tegtmeier BR, et al.** Late cytomegalovirus disease in marrow transplantation is predicted by virus load in plasma. *J. Infect. Dis.* 1997;176:782–785.
- Zoulim F.** New nucleic acid diagnostic tests in viral hepatitis. *Semin Liver Dis.* 2006;26:309–317.