

Original Article

Validation of the fear of the COVID-19 scale in Nigeria: Implications for public health practice



Terkuma Chia, M.Sc^{a,*}, Oluwatosin I. Oyeniran, M.Sc^b and Steven K. Iorfa, M.Sc^c

^a Department of Anatomy, Faculty of Basic Medical Sciences, College of Health Sciences, Nile University of Nigeria, Abuja, Nigeria

^b Department of Physiology, Faculty of Basic Medical Sciences, College of Health Sciences, Nile University of Nigeria, Abuja, Nigeria

^c Department of Psychology, University of Nigeria, Nsukka, Nigeria

Received 9 March 2021; revised 5 May 2021; accepted 8 May 2021; Available online 12 June 2021

المخلص

أهداف البحث: أثر الخوف من جائحة كوفيد-19 على مجموعة واسعة من المواقف والسلوكيات المتعلقة بالصحة في جميع أنحاء العالم. ومع ذلك، داخل السكان الأفارقة، ليس من الواضح كيف يمكن أن يكون الخوف من جائحة كوفيد-19 مهمًا بشكل خاص لصياغة سياسات الصحة العامة وتنفيذها اللاحق. كخطوة أولى، من المهم التحقق من صحة أداة القياس النفسي لتقييم الخوف من جائحة كوفيد-19 باستخدام السكان الأفارقة. تقدم هذه الدراسة التحقق الأولي من مقياس الخوف من كوفيد-19 باستخدام سكان إفريقيا جنوب الصحراء من نيجيريا.

طرق البحث: من إجمالي 1000 مدعو، استجاب 398 مدعوا. وطلب من المشاركين ملء استبانة مقياس الخوف من كوفيد-19 على شبكة الإنترنت (نماذج حوّل). تم تحليل الردود، إلى جانب بياناتهم الاجتماعية والديموغرافية، باستخدام الإحصاء الوصفي وتحليل العوامل المؤكدة.

النتائج: تراوحت أعمار المشاركين بين 21 و 30 عاما (متوسط 25.84 عاما). يتألف المشاركون في الدراسة من 220 من الذكور (56.6%) و 169 من الإناث (43.4%). وصلت عمليات تحميل العوامل لجميع العناصر السبعة في استبانة مقياس الخوف من كوفيد-19 إلى دلالة إحصائية، وبالتالي، تم الاحتفاظ بها. أشار تحليل العامل التأكيدي إلى أن الهيكل الثنائي لاستبانة مقياس الخوف من كوفيد-19 كان مناسبًا بشكل أفضل للتجمعات السكانية الفرعية النيجيرية قيد الدراسة. وكانت ألفا كرونباخ لكلا المقياسين الفرعيين مقبولة.

الاستنتاجات: يعتبر مقياس الخوف من كوفيد-19 أداة صالحة ومناسبة وفعالة للسكان الأفارقة. بالإضافة إلى ذلك، فإن الآثار المترتبة على استخدامه لممارسة الصحة العامة في أفريقيا أمر ضروري.

الكلمات المفتاحية: أفريقيا؛ كوفيد-19؛ الخوف؛ نيجيريا؛ الصحة العامة؛ مصادقة

Abstract

Objective: The fear of the COVID-19 pandemic has affected a wide range of health-related attitudes and behaviours worldwide. However, within an African population, it is not clear how the fear of the COVID-19 pandemic may be particularly important for formulating public health policies and their consequent implementation. As a first step, it is important to validate a psychometrically sound instrument to assess the fear of the COVID-19 pandemic using an African population. This study presents a preliminary validation of the fear of the COVID-19 Scale (FCV-19S) using a sub-Saharan African population from Nigeria.

Methods: Three hundred and eighty-nine people responded from a total of 1000 invitees. The participants were requested to fill a web-based (Google forms) FCV-19S questionnaire. The responses, together with their socio-demographic data, were analysed using descriptive statistics and a confirmatory factor analysis.

Results: The age of the participants ranged between 21 and 30 years (mean 25.84 years). The study participants comprised 220 males (56.6%) and 169 females (43.4%). The factor loadings of all seven items of the FCV-19S questionnaire reached statistical significance and,

* Corresponding address: Department of Anatomy, Faculty of Basic Medical Sciences, College of Health Sciences, Nile University of Nigeria, Abuja, Nigeria.

E-mail: terkumachia@hotmail.com (T. Chia)

Peer review under responsibility of Taibah University.



therefore, were retained. The confirmatory factor analysis indicated that the two-factor structure of the FCV-19S questionnaire was a better fit for the Nigerian subpopulation under consideration. Cronbach's alphas for both subscales were acceptable.

Conclusions: The FCV-19S is a valid, suitable, and effective tool for the African population. Additionally, the implications of its use for public health practice in Africa are essential.

Keywords: Africa; COVID-19; Fear; Nigeria; Public health; Validation

© 2021 The Authors.

Production and hosting by Elsevier Ltd on behalf of Taibah University. This is an open access article under the CC BY-NC-ND license (<http://creativecommons.org/licenses/by-nc-nd/4.0/>).

Introduction

For most people in the world today, the coronavirus disease 2019 (COVID-19) pandemic is a first-time pandemic experience. The last recorded pandemic of the same magnitude was the Spanish flu which lasted from 1918 to 1920 and resulted in an estimated 50 million deaths.¹ COVID-19, since its emergence in China, has spread to every region and country of the globe, resulting in 59,814,726 infections and 1,410,190 deaths worldwide as of 25th November 2020.² According to the COVID-19 Africa Watch, 2,077,611 cases of COVID-19 have been reported in Africa with mortalities of 49,961 as of 25th November 2020.³ In terms of number of infections and corresponding mortalities, the top ten most affected countries in Africa are: South Africa (769,759; 21,083), Morocco (327,528; 5,469), Egypt (113,381; 6,573), Ethiopia (106,203; 1,661), Tunisia (89,195; 2,935), Libya (78,473; 1,125), Kenya (77,785; 1,409), Algeria (75,867; 2,309), Nigeria (66,439; 1,169), and Ghana (50,941; 323).³

The rapid infection rate of the virus and its associated fatalities has led to anxiety and panic of varying degrees,^{4–9} alongside negative impacts on lifestyles¹⁰ and livelihoods.¹¹ More so, the spike in COVID-19 cases and several phases of COVID-19 waves have forced swift public health interventions by the governments of many nations,¹² including the prohibition of mass gatherings,¹³ increase in laboratory testing capacities,¹⁴ healthcare system and policies overhauls,^{15,16} amongst others. This could be linked to the unavailability of a definitive drug or vaccine¹⁷ and further compounded by the series of conspiracy theories being propounded especially via social media channels.^{18,19} It is common that in circumstances of uncertainties as this pandemic, individuals will exhibit varying degrees of emotions depending on their perceptions. One such emotion is fear, an unfriendly emotional state generated by the sensitivity of an aggressive stimulus.²⁰ Although research has revealed that fear may guide individuals to engage in precautionary measures,²¹ it is unclear how exactly this may be happening, what level of fear would be sufficient, and what mechanisms may be responsible for

translating fear into precautionary actions. It is, therefore, necessary that a robust, psychometrically valid, and dependable tool for evaluating fear of COVID-19 be put in place if the consequence of fear of COVID-19 on all other outcomes is to be scientifically determined. Such a psychometrically sound tool would be instrumental in properly gauging human behavioural responses to this pandemic and would also help enlighten public health policies and practices.

Therefore, in response to the need for a sound psychometric tool, Ahorsu et al.²¹ established the Fear of COVID-19 Scale (FCV-19S), a psychological tool for assessing the fear of COVID-19 in individuals. The initial form of the FCV-19S had ten items, but upon testing, three items failed and were subsequently expunged, resulting in the final version of seven items. Ahorsu et al.²¹ reported a one-factor structure for the 7-item FCV-19S. Subsequently, Reznik et al.²² and Bitan et al.²³ proposed a two-factor structure that reportedly performed better than the unidimensional structure proposed by the developers. The FCV-19S, since its development, has received increased attention from researchers across the board, supporting its reliability across cultures and contexts.^{23–31} This paper, therefore, presents the first known validation of the fear of the COVID-19 scale employing an African population.

A valid assessment instrument of fear of COVID-19 within the African setting would aid public health decisions and practice in several ways. Specifically, by assessing the baseline fear levels of the population, better policies would be put in place and subsequently implemented. Already, research has shown that functional fear envisages health acquiescence during the COVID-19 pandemic,³² including mental health.³³ The chief aim of this research is to assess the psychometric characteristic of FCV-19S within a Nigerian population, thereby permitting cross-cultural studies and providing comparable data with other studied populations. We hypothesized that the FCV-19S is a valid and reliable scale to assess COVID fear in the Nigerian population.

Materials and Methods

Study setting and sample

The participants in this study were randomly recruited across Nigeria during the pandemic lockdown. An online cross-sectional survey design was adopted, and the questionnaire designed as a 'Google Form' was circulated via WhatsApp and Facebook from September 10th to November 10th, 2020. Participants consented and willingly took part in the survey, which resulted in a sample of 389 Nigerians.

Measurement of the fear of COVID-19 scale (FCV-19S)

The 7-item FCV-19S (English version) established by Ahorsu et al.²¹ was used as the study instrument. An additional section of the survey obtained information on the socio-demography, including the highest educational attainment and occupation of the respondents. Ahorsu et al.²¹ reported factor loadings between 0.66 and 0.74 and corrected item–total correlation ranging from 0.47 to 0.56.

The internal consistency coefficient and test-retest reliability (ICC) stood at 0.82 and 0.72, respectively.²¹ Reznik et al.²² further validated the FCV-19S, delineating two factors from the original one-factor structure. They stated a composite Cronbach's alpha reliability of .81.

Data collection

Employing a 5-point Likert scale response format, respondents chose from 1 (strongly disagree) to 5 (strongly agree) depending on the extent to which individual questions applied to them. The entire score fell between 7 and 35, in which a greater score indicates more fear of COVID-19. This validation study was performed using Nigerians recruited through an online convenient sampling technique. Based on the limitations posed by restrictions through the initial pandemic phase, research data were collected from the respondents through Google Forms. The Google Form link containing a brief description of the study, socio-demographic questions, and the FCV-19S was widely shared on social media platforms for four weeks. A total of 389 responses were received which are sufficiently powered to perform factor analysis. VanVoorhis and Morgan³⁴ termed a sample size of ≥ 300 'as good' for factor analysis.

Data analysis

The participants' characteristics were descriptively analysed. The data generated from the participants' responses were analysed using SPSS for Windows v21 and SPSS AMOS v24. Data were presented as measures of central tendency, dispersion, frequencies, and percentages, as well as indices of internal reliability and validity using a confirmatory factor analysis (CFA). Fit indices considered from the CFA were the normed chi-square (χ^2/df), Comparative Fit Index (CFI), Tucker–Lewis Index (TLI), Goodness of Fit Index (GFI), Incremental Fit Index (IFI), and the Root Mean Square Error of Approximation (RMSEA). The normed chi-square (χ^2/df) below the cut-off value of 3.0³⁵ or 5.0³⁶ is recommended. The CFI, TLI, IFI, and GFI values greater than .90 are acceptable fits, while values greater than .95 are most preferred. RMSEA values lower than .10 indicate an acceptable fit, while values lower than .05 indicate a good fit.^{37,38}

Results

Demographic characteristics of study participants

The characteristic of the respondents showed that 389 people participated in the study, of which 220 (56.6%) were males while 169 (43.4%) were females. Age distribution was as follows: below age 20 ($n = 16$, 4.1%), age 21 to 30 ($n = 252$, 64.8%), age 31 to 40 ($n = 105$, 27.0%), age 41 to 50 ($n = 13$, 3.3%) and 51 to 60 ($n = 3$, 0.8%). Further details of the respondents, including civil status, highest educational attainment, and occupation, are shown in Table 1. Out of the possible 35 obtainable scores, participants scored a mean value of 18.19, representing their fear of COVID-19. The individual item means are shown in Table 2.

Table 1: Sociodemographic characteristics of study participants.

Variables		Frequency	Percentage
Gender	Male	220	56.6
	Female	169	43.4
Age Range	<20	16	4.1
	21–30	252	64.8
	31–40	105	27.0
	41–50	13	3.3
	51–60	3	.8
Civil Status	Never Married	243	62.5
	Married	141	36.2
	Widowed	5	1.3
Highest Educational Attainment	Primary	1	.3
	Secondary	124	31.9
	Tertiary	169	43.4
	Postgraduate	95	24.4
Occupation	Student	121	31.1
	Self-employed	79	20.3
	Government Employed	62	15.9
	Privately Employed	127	32.6
	Employed		

With a total Cronbach's Alpha coefficient of 0.904, as displayed in Table 3, the scale indicates good internal consistency. Additionally, Table 3 displays the inter-item correlations, item–total correlation, and component matrix correlation of the scale.

Following a reported two-factor structure for the FCV-19S,²² we subjected our data to preliminary factor analyses and obtained a two-factor rotated matrix as shown in Table 3. The first four items clustered around the first component, while the last three clustered around the

Table 2: Mean scores for items of the FCV-19S and Cronbach's alpha if item is deleted.²¹

Items	Mean (SD) (n = 389)	Cronbach's alpha if item is deleted
I can't sleep due to worries of getting the coronavirus.	1.78(1.16)	.898
I'm most afraid of the coronavirus.	3.00(1.48)	.891
I feel uncomfortable thinking about the coronavirus.	3.09(1.50)	.898
I'm afraid of losing my life due to the coronavirus	2.97(1.58)	.887
I become nervous or anxious whenever I watch news and stories regarding the coronavirus on social media	2.86(1.53)	.885
I develop clammy hands when I think of the coronavirus	2.32(1.44)	.888
Thoughts of getting the coronavirus races or palpitates my heart	2.17(1.40)	.883
Total Mean (Cronbach's Alpha)	18.19	(.904)

***p < 0.001 (t test)

Table 3: Inter-item correlation matrix.

Items (n = 389)	1	2	3	4	5	6	CITC	C1	C2
I'm most afraid of the coronavirus							0.708	0.853	
I feel uncomfortable thinking about the coronavirus	.58**						0.65	0.769	
I'm afraid of losing my life due to the coronavirus	.66**	.56**					0.74	0.735	
I become nervous or anxious whenever I watch news and stories regarding the coronavirus on social media	.57**	.61**	.65**				0.76	0.704	
I develop clammy hands when I think of the coronavirus	.55**	.51**	.57**	.65**			0.737	0.912	
I can't sleep due to worries of getting the coronavirus	.48**	.38**	.50**	.50**	.60**		0.647	0.814	
Thinking about getting the coronavirus races or palpitates my heart	.60**	.49**	.61**	.62**	.65**	.74**	0.782	0.684	

**= A significant at the 0.01 level (2-tailed). CITC= Corrected Item–Total Correlation; C1= Component 1; C2= Component 2.

Table 4: Summary of reliability and validity fit indices for the FCV-19S

Measures	χ^2	Df	χ^2/df	CFI	NFI	GFI	RMR	RMSEA (90%CI)	α
2-Factor FCS	67.32	13	5.18	.80	.96	.95	.11	.10(.08–.13)	.94 (.86, .86)
1-Factor FCS	97.18	14	6.94	.68	.63	.93	.12	.12(.10–.15)	.94

Note. α = Cronbach's alpha (>0.6 proposes adequate internal reliability, <0.6 proposes poor internal reliability; values in brackets represents co-efficient for dimensions) CFI: comparative fit index (>0.95 proposes good fit, >0.9 proposes adequate fit, <0.9 proposes poor fit); TLI: Tucker Lewis Index(> 0.95 shows good fit, >0.9 proposes adequate fit, <0.9 proposes poor fit); RMSEA: Root Mean Square Error of Approximation (<0.05 proposes good fit, <0.08 proposes adequate fit, >0.08 proposes poor fit); GFI: Goodness of fit Index (> 0.95 shows good fit, >0.9 proposes adequate fit, <0.9 proposes poor fit) CI: confidence interval.

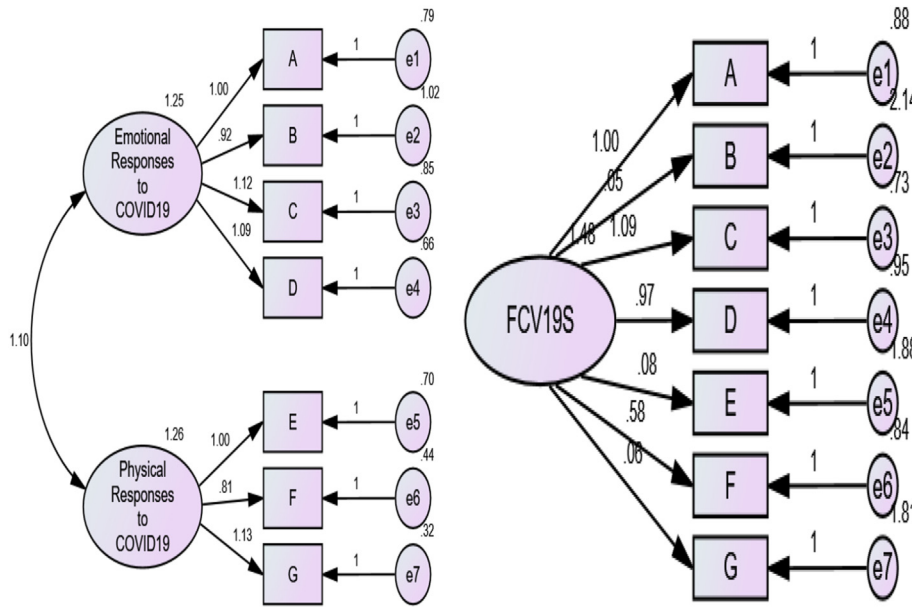

Figure 1: Diagrams showing the structure of the two-factor model of FCV-19S

second component, mirroring the emotional response and physical response dimensions of COVID-19 fear.²²

To further confirm the two-factor structure, we conducted a CFA to know if the two-factor structure would be replicated in an African population and whether it would yield a better fit than the one-factor structure earlier proposed. Overall, the FCV-19S did not perform as excellently as expected using the CFA fit indices. However, it was observed that the two-factor structure proposed by Reznik et al.²² performed better than the unidimensional structure of

Ahorsu et al.²¹ The fit indices for the two structures are shown in Table 4 below. A path diagram showing the structure of the two-factor model is also presented in Figure 1 with the unstandardized factor weights displayed.

Discussion

The central purpose of this research was to validate the FCV-19S in an African population, drawing a sample from Nigeria. It was hypothesized that the FCV-19S would be

valid and reliable within a Nigerian population. This hypothesis is confirmed by this study. The study revealed that FCV-19S is a dependable measure of COVID-19 fear among Nigerians. Factor loadings and structure were all significant and replicated those observed in previous studies.^{21–23} Although CFA results showed that both structures were not the best fit using the present data set, the two-factor model performed better than the unidimensional model. The two factors extracted were the emotional reactions to COVID-19 (Items 1–4) and the physical reactions to COVID-19 (Items 5–7).

Interestingly, the internal consistency of the FCV-19S obtained from this research was higher compared to that obtained in previous studies using different populations: (the US) 0.91,³² (the UK) 0.87,³³ (Iran) 0.82,²¹ and (Eastern Europe) 0.81.²² Hence, we can establish that the FCV-19S has good internal consistency. CFA outcomes indicated that the FCV-19S did not yield very acceptable fit indices using the present dataset; however, a more accepted model was the two-factor structure. Generally, the results obtained from the statistical analyses reveal that FCV-19S possesses sufficient properties for its purpose. These results agree with previous studies conducted in various climes among varying samples.

The knowledge of FCV-19S validity among an African sample has the following implications for research and public health practice. Firstly, researchers can now employ the FCV-19S and obtain a valid assessment of fear of COVID-19 among the population. The effect of fear of COVID-19 on mental health outcomes and other variables can also be scientifically determined. Earlier studies revealed that the fear of COVID-19 has implications for hindered access or delivery of care,^{39–42} and it would be important to anticipate similar occurrences in Africa should a second wave arise. This can only be done with a proper assessment of the fear of the COVID-19 situation within the region.

Study limitations

Due to the peculiarities of the COVID-19 pandemic, convenience sampling was used. Therefore, the findings are not readily generalizable. Secondly, individuals reported about themselves, thereby creating a possibility of bias. However, putting the mean of the respondents together, the data is a fair representation of the fear of COVID-19 among Nigerians. More rigorous forms of validation, such as criterion-related validities, which could serve as more robust indices of reliability and validity, were not conducted. Future studies may improve on the present shortcomings.

Conclusion

From the findings of this present research, we conclude that the fear of the COVID-19 Scale (FCV-19S) is valid, suitable, and purposeful in the African population.

Recommendations

Future validation studies using the African population should employ criterion-related validities, which could serve as more robust indices of reliability and validity.

Source of funding

This research did not receive any specific grant from funding agencies in the public, commercial, or not-for-profit sectors.

Conflict of interest

The authors have no conflict of interest to declare.

Ethical approval

This study was carried out following the Declaration of Helsinki. It was reviewed and granted ethical approval (UNN/ERB/2020/030) by the Ethics Committee of the University of Nigeria, Nsukka on August 23rd 2020.

Consent

All participants were advised concerning the study objective and gave informed consent before their enrolment.

Authors' contributions

TC and OIO initiated and planned the study. TC, OIO, and SKI carried out the investigation. All authors obtained, sorted, analysed, and presented the data. All authors critically reviewed and approved the final draft and are responsible for the content and similarity index of the manuscript.

Acknowledgment

We recognise Mr. Alexander Monday Etuh for his assistance and survey follow-up activities.

References

1. Dasgupta S, Crunkhorn R. A History of pandemics over the ages and the human cost. *Physician* 2020; 6(2): 1–9.
2. John Hopkins University & Medicine. *Coronavirus resource center. COVID-19 case tracker*; 2020 [Accessed 25 Nov, 2020]. Available at: <https://www.coronavirus.jhu.edu/map.html>.
3. COVID-19 Africa Watch, Milken Institute. *Data & charts*; 2020 [Accessed 25 Nov, 2020]. Available at: <https://covid19africawatch.org/data-and-charts/>.
4. Ajagbe AO, Onigbinde OA, Oyeniran OI, Terkuma CH. Mental morbidity arising from social isolation during Covid-19 outbreak. *Ulutas Med J* 2020; 6(2): 97–100.
5. Rakhmanov O, Dane S. Knowledge and anxiety levels of African university students against COVID-19 during the pandemic outbreak by an online survey. *J Res Med Dent Sci* 2020; 8: 53–56.
6. Chia T, Oyeniran OI. Human health versus human rights: an emerging ethical dilemma arising from coronavirus disease pandemic. *Ethics Med Publ Health* 2020; 14: 100511.
7. Rakhmanov O, Demir A, Dane S. A brief communication: anxiety and depression levels in the staff of a Nigerian private university during COVID 19 pandemic outbreak. *J Res Med Dent Sci* 2020; 8: 118–122.
8. Chia T, Oyeniran OI. Will Africa experience a spike in COVID-19 cases? *Asian Pac J Trop Med* 2020; 13(7): 285–287.

9. Rakhmanov O, Shaimerdenov Y, Dane S. The effects of COVID-19 pandemic on anxiety in secondary school students. **J Res Med Dent Sci** 2020; 8: 186–190.
10. Rakhmanov O, Shaimerdenov Y, Nacakgedigi O, Dane S. COVID-19 outbreak negatively impacted Nigerian secondary school students lifestyles. **J Res Med Dent Sci** 2021; 9(2): 279–284.
11. Celik B, Ozden K, Dane S. The effects of COVID-19 pandemic outbreak on the household economy. **J Res Med Dent Sci** 2020; 8: 51–56.
12. Oyeniran OI, Chia T. Novel Coronavirus disease 2019 (COVID-19) outbreak in Nigeria: how effective are government interventions? **Ethics Med Publ Health** 2020; 14: 100515.
13. Oyeniran O, Terkuma CH, Onigbinde O, Ajagbe A. Avoiding an imminent catastrophe from COVID-19 pandemic in Africa: the need to urgently prohibit mass gatherings. **Cumhuriyet Tip Dergisi** 2020; 42(2): 203–207.
14. Oyeniran OI, Chia T, Oraebosi MI. Combating covid-19 pandemic in Africa: an urgent call to scale up laboratory testing capacities. **Ethics Med Publ Health** 2020; 15: 100552.
15. Oraebosi MI, Chia T, Oyeniran OI. Preparing the next generation of African healthcare and scientists: lessons from coronavirus pandemic. **Ethics Med Publ Health** 2020; 14: 100535.
16. Igyuse SS, Chia T, Oyeniran OI. Implications of coronavirus pandemic on public health policy in Africa. **Cumhuriyet Med J** 2020; 42(3): 255–258.
17. Iorfa SK, Ottu IFA, Oguntayo R, Ayandele O, Kolawole SO, Gandi JC, et al. COVID-19 knowledge, risk perception, and precautionary behavior among Nigerians: a moderated mediation approach. **Front Psychol** 2020; 11: 566773.
18. Chukwuorji JC, Iorfa SK. Commentary on the coronavirus pandemic: Nigeria. **Psychol Trauma** 2020; 12(S1): S188–S190.
19. Romer D, Jamieson KH. Conspiracy theories as barriers to controlling the spread of COVID-19 in the U.S. **Soc Sci Med** 2020; 263: 113356.
20. Yildirim M, Geçer E, Akgül Ö. The impacts of vulnerability, perceived risk, and fear on preventive behaviours against COVID-19. **Psychol Health Med** 2020; 26(1): 35–43.
21. Ahorsu DK, Lin CY, Imani V, Saffari M, Griffiths MD, Pakpour AH. The fear of COVID-19 scale: development and initial validation. **Int J Ment Health Addiction** 2020; Mar 27: 1–9.
22. Reznik A, Gritsenko V, Konstantinov V, Khamenka N, Isralowitz R. COVID-19 fear in eastern Europe: validation of the fear of COVID-19 scale. **Int J Ment Health Addiction** 2020; May 12: 1–6.
23. Bitan DT, Grossman-Giron A, Bloch Y, Mayer Y, Shiffman N, Mendlovic S. Fear of COVID-19 scale: psychometric characteristics, reliability and validity in the Israeli population. **Psychiatr Res** 2020; 289: 113100.
24. Soraci P, Ferrari A, Abbiati FA, Del Fante E, De Pace R, Urso A, et al. Validation and psychometric evaluation of the Italian version of the Fear of COVID-19 Scale. **Int J Ment Health Addiction** 2020; May 4: 1–10.
25. Sakib N, Bhuiyan AI, Hossain S, Al Mamun F, Hosen I, Abdullah AH, et al. Psychometric validation of the bangla fear of COVID-19 scale: confirmatory factor analysis and rasch analysis. **Int J Ment Health Addiction** 2020; May 11: 1–12.
26. Martínez-Lorca M, Martínez-Lorca A, Criado-ÁlvarezJJ, Armesilla MD. The fear of COVID-19 scale: validation in Spanish university students. **Psychiatr Res** 2020; 293: 113350.
27. Alyami M, Henning M, Krägeloh CU, Alyami H. Psychometric evaluation of the Arabic version of the fear of COVID-19 scale. **Int J Ment Health Addiction** 2020; May 16: 1–14.
28. Haktanir A, Seki T, Dilmaç B. Adaptation and evaluation of Turkish version of the fear of COVID-19 scale. **Death Stud** 2020; May 28: 1–9.
29. Pang NT, Kamu A, Hambali NL, Mun HC, Kassim MA, Mohamed NH, et al. Malay version of the fear of COVID-19 scale: validity and reliability. **Int J Ment Health Addiction** 2020; Jul 3: 1–10.
30. Martínez-Lorca M, Martínez-Lorca A, Criado-ÁlvarezJJ, Armesilla MD. The fear of COVID-19 scale: validation in Spanish university students. **Psychiatr Res** 2020; 293: 113350.
31. Chang KC, Hou WL, Pakpour AH, Lin CY, Griffiths MD. Psychometric testing of three COVID-19-related scales among people with mental illness. **Int J Ment Health Addiction** 2020; Jul 11: 1–13.
32. Perz CA, Lang BA, Harrington R. Validation of the fear of COVID-19 scale in a US college sample. **Int J Ment Health Addiction** 2020; Jun 25: 1–11.
33. Harper CA, Satchell LP, Fido D, Latzman RD. Functional fear predicts public health compliance in the COVID-19 pandemic. **Int J Ment Health Addiction** 2020; Apr 27: 1–14.
34. VanVoorhis CW, Morgan BL. Understanding power and rules of thumb for determining sample sizes. **Tutor Quant Methods Psychol** 2007; 3(2): 43–50.
35. Kline RB. *Principles and practices of structural equation modeling*. 2nd ed. New York: Guilford; 2005.
36. Bentler PM. Comparative fit indexes in structural models. **Psychol Bull** 1990; 107(2): 238–246.
37. Hu L, Bentler PM. Cutoff criteria for fit indexes in covariance structure analysis: conventional criteria versus new alternatives. **Struct Equ Model** 1999; 6(1): 1–55.
38. Kline RB. *Principles and practices of structural equation modeling*. 3rd ed. New York: Guilford; 2010.
39. Lazznerini M, Barbi E, Apicella A, Marchetti F, Cardinale F, Trobia G. Delayed access or provision of care in Italy resulting from fear of COVID-19. **Lancet Child Adolesc Health** 2020; 4(5): e10–e11.
40. Megalakaki O, Kokou-Kpolou CK, Vaudé J, Park S, Iorfa SK, Derivois D. Does peritraumatic distress predict PTSD, depression and anxiety symptoms during and after COVID-19 lockdown in France? A prospective longitudinal study (2021) **J Psychiatr Res** 2021. <https://doi.org/10.1016/j.jpsychires.2021.02.035>.
41. Ojiaku MC, Iorfa SK, Mefoh PC, Ezeuzo OD, Odinko IC. COVID-19-Induced anxiety and COVID-19 precautionary measures as predictors of mental wellbeing of Nigerians. **Int J Behav Sci** 2020; 14(3): 149–154.
42. Olapegba PO, Iorfa SK, Kolawole SO, Oguntayo R, Ghandi JC, Ottu IF, Ayandele O. Survey data of COVID-19-related knowledge, risk perceptions and precautionary behavior among Nigerians. **Data Brief** 2020; 30: 105685.

How to cite this article: Chia T, Oyeniran OI, Iorfa SK. Validation of the fear of the COVID-19 scale in Nigeria: Implications for public health practice. *J Taibah Univ Med Sc* 2021;16(6):929–934.