

# Micro- and nanofabrication methods in nanotechnological medical and pharmaceutical devices

Tania Betancourt  
Lisa Brannon-Peppas

Department of Biomedical  
Engineering, University of Texas  
at Austin, TX, USA

---

**Abstract:** Micro- and nanofabrication techniques have revolutionized the pharmaceutical and medical fields as they offer the possibility for highly reproducible mass-fabrication of systems with complex geometries and functionalities, including novel drug delivery systems and biosensors. The principal micro- and nanofabrication techniques are described, including photolithography, soft lithography, film deposition, etching, bonding, molecular self assembly, electrically induced nanopatterning, rapid prototyping, and electron, X-ray, colloidal monolayer, and focused ion beam lithography. Application of these techniques for the fabrication of drug delivery and biosensing systems including injectable, implantable, transdermal, and mucoadhesive devices is described.

**Keywords:** microfabrication, nanofabrication, medical devices, drug delivery, biosensors

---

## Introduction

Micro- and nanodevices have many advantages over their macroscale counterparts. For instance, miniaturization allows for the manufacture of portable, hand-held, implantable, or even injectable devices. In addition, as a result of their minute size, these devices need less sample or reagent for analysis or operation, saving money and time. Moreover, where materials and/or processes are inhibited by lengthy diffusion times, miniaturization provides a mechanism for abbreviating these. A notable example where these microdevices allow for significant advantages over traditional technologies is in medical care. For example, point-of-care diagnostic testing, which is testing performed at the patient's bedside, permits physicians to diagnose a patient's conditions more rapidly than conventional lab-based testing. By using these devices to reduce the time to diagnoses, the physician is able to make better patient management decisions leading to improved patient outcomes and reduce the overall cost of care. Advances in microelectronics and biosensor tools have been instrumental in facilitating the development of these point-of-care diagnostic devices.

Microfabrication techniques were developed for applications in the semiconductor industry and are, consequently, not specific for biological or medical applications. Nonetheless, both micro- and nanofabrication have offered a number of possibilities for the study of chemical, biological, and physical processes at the cellular and molecular scale, and for the design of synthetic devices capable of interacting with biological systems at these levels.

Some of the advantages of micro- and nanofabricated devices include the ability to control the features to the nanometer scale for reproducible mass production of structures and devices, the ability to miniaturize already-existing systems for the study of cellular or molecular processes, the capacity of including electronics within structural devices through the use of the well-developed semiconductor techniques, and the high throughput possible with some of the micro- and nanofabrication methods.

---

Correspondence: Lisa Brannon-Peppas  
Department of Biomedical Engineering,  
The University of Texas at Austin,  
1 University Station C0300, Austin, TX  
78712, USA  
Tel +1 512 471 4348  
Fax +1 512 471 4348  
Email peppas@mail.utexas.edu

The integration of the knowledge gained from micro- and nano-fabrication can lead to design principles for nanodevices that can detect substances, analyze their environment, and perform tasks such as the release of a specific molecule. These vehicles will combine responsive polymers, nanoparticles, nucleotides, and micro-electromechanical systems (MEMS) elements.

Expertise in combining MEMS systems with environmentally sensitive polymers has led to the design of controlled release systems. For example, research in physiologically responsive materials shows how it is possible to design devices which are responsive to changes in the surrounding environment. Biological molecular recognition systems have been used widely in designing novel devices such as DNA-fueled molecular machines (Seeman 2003; Yurke et al 2003), tailored colloidal aggregates, and biomolecular nanomechanical sensors. We have also expertise in the controlled release of therapeutics, and in modifying the targeting and release properties of biodegradable nanoparticles (Blanchette et al 2004; Brannon-Peppas and Blanchette 2004). It will be important to integrate MEMS technology into the biological environment, as with polymeric nanoparticle delivery systems, and microfabricated nano- and microcontainers with responsive delivery systems (sensor-controlled delivery).

Finally, investigation of intelligent nanoscale systems with the ability of the molecules themselves to make decisions is needed in our field. Nucleic acids are likely the best candidates for sensing, transducing, deciding, and treating, as demonstrated by nucleic acid “gates” that can sense analytes, integrate information, and carry out reactions that would in turn lead to the release of therapeutic molecules, such as siRNAs. By integrating these technologies with novel drug delivery methods, it should prove possible to make extremely “smart” therapeutics.

This review focuses on the diverse micro- and nano-fabrication techniques available, and on the applications of these techniques into the construction of devices for medical applications. However, because of the vast number of techniques that have been developed in the recent years for very specific applications, this review is by no means exhaustive.

## Microfabrication techniques

A number of techniques are used for the fabrication of micron-scale devices. Some of these techniques have been adopted from the well-established field of semiconductors, but others have been specifically developed for microfabrication.

The microfabrication process utilizes these techniques in a sequential manner to produce the desired structure. These structures can be built within the bulk of a substrate material in what is known as bulk micromachining, or on the surface of the substrate through surface micromachining (Voldman et al 1999). In most cases, however, a combination of bulk and surface micromachining is utilized in the fabrication of the desired system.

The most important microfabrication techniques are photolithography, soft lithography, film deposition, etching, and bonding. Photolithography is used to transfer a user-generated shape onto a material through the selective exposure of a light sensitive polymer. Soft lithography encompasses three different techniques which are all based on the generation and utilization of the mold of a microstructure out of poly(dimethylsiloxane). Film deposition, as its name suggest, consists of the formation of micron-thick films on the surface of a substrate. Etching selectively removes materials from the surface of the microdevice by either chemical or physical processes. Finally, bonding adheres substrates together with or without the use of intermediary layers. The following section will discuss these and other techniques in more detail.

## Photolithography

Photolithography is one of the most readily employed microfabrication techniques and is used to create patterns into a material. The photolithographic technique has been reviewed thoroughly previously (Voldman et al 1999; Li et al 2003). The photolithographic process consists of a number of steps in which a desired pattern is generated on the surface of a substrate through exposure of regions of a light-sensitive material to ultraviolet (UV) light. Figure 1 summarizes the main steps followed in photolithography.

In the first step, a substrate material, such as silicone or glass, is coated with a layer of a photoresist, or light-sensitive polymer. A photomask, made by patterning with an opaque material the desired shape on a glass dish or other transparent material, is placed on top of the substrate and photoresist. This assembly is then irradiated with UV light, thus exposing the sections of the photoresist not covered by the opaque regions of the photomask. Depending on the type of photoresist utilized, the photoresist polymer will undergo one of two possible transformations upon exposure to light. When light illuminates a positive photoresist, the exposed regions break down and become more soluble in a developing solution. As a result, the exposed photoresist can be removed when in contact with the developing solution. A negative photoresist,

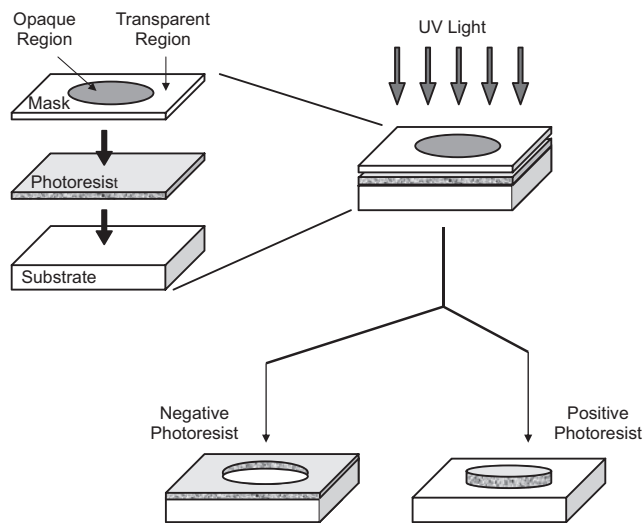

**Figure 1** Process of photolithography. A mask with opaque regions in the desired pattern is used to selectively illuminate a light-sensitive photoresist. Depending on the type of photoresist utilized, it will become more soluble (positive photoresist) or crosslinked (negative photoresist) after UV light exposure, thus generating the appropriate pattern upon developing.

on the other hand, becomes crosslinked upon exposure to light, thus becoming insoluble in the developing solution. Consequently, upon contact with the developing solution, only the parts not exposed to light will be removed.

The resulting photoresist patterns are then used to protect the covered substrate from etching, or from the deposition of compounds or biomolecules on its surface. After the desired process is completed, the photoresist can be removed, leaving the pattern design on the substrate. The technique used for photoresist removal usually consists of sonication in an organic solvent, and may consequently be undesirable for a number of systems, specially those containing biological molecules. As an alternative, water-soluble photoresists have been developed; however, concerns about the efficiency of water-soluble photoresist removal have been reported (Li et al 2003).

One of the most commonly used photoresist is SU-8, originally developed by IBM, and currently marketed by MicroChem Corporation (Newton, MA, USA), and SOTEC Microsystems (Renens, Switzerland). This negative photoresist is crosslinked upon exposure of near UV energy in the range of 350 to 400 nm, and can be developed with a number of substances including propyleneglycol monoether acetate, ethyl acetate and diacetone alcohol. One of the main advantages of SU-8 is that it permits generation of tall structures, of more than 1000  $\mu\text{m}$  in height (Becker and Gärtner 2000).

Photolithography has reached wide acceptance in the field of microfabrication because of the high resolution and

variety of pattern attributes that are possible to obtain, both of which depend on the characteristics of the photomask. Nonetheless, this technique has the limitation of requiring clean room processing.

## Soft lithography

Soft lithography, similarly to photolithography, is a method also used to transfer a pattern onto a surface. It utilizes a microstructure replica produced by molding a polymer, such as poly(dimethyl siloxane) (PDMS) to a master, which is manufactured through other microfabrication techniques such as photolithography (Li et al 2003). PDMS has been readily used in the biomedical and pharmaceutical fields because of its biocompatibility, and good thermal, mechanical and optical properties. The main advantage of soft lithography is that once the reusable mold is made, none of the other steps require clean room manipulation. As a result, it is a less expensive technique that provides great resolution through a simpler process (Li et al 2003). A great review on soft lithographic methods was previously published (Xia and Whitesides 1998).

There are three main soft lithography processes: micro-stamping, stencil patterning, and microfluidic patterning. Figure 2 depicts these three microfabrication methods.

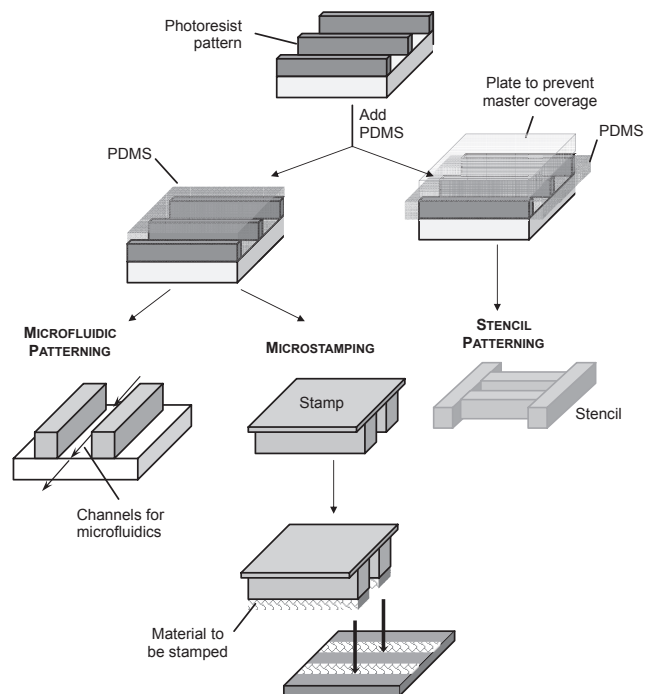

**Figure 2** Soft lithography includes the techniques of microfluidic patterning, microstamping and stencil patterning. All three techniques are based on the generation of the replica of a microstructure from a poly(dimethyl siloxane) (PDMS) mold prepared through other microfabrication methods such as photolithography.

Microstamping, also known as microcontact printing, is based on the construction of a stamp that has the desired pattern with the PDMS mold. Molecules to be transferred are placed on the surface of the stamp and “printed” on a receiving surface upon stamping, thus forming a self-assembled monolayer (SAM) (Voldman et al 1999; Chen and Pepin 2001; Curtis and Wilkinson 2001). Depending on the application, peptides, proteins, polysaccharides and other molecules can be stamped. The stamped layer can protect the substrate during etching or deposition procedures, which will be described in more detail later in this section. One great advantage of this microfabrication method is that the stamp can be reused to make pattern replicas.

The second soft lithography technique, stencil patterning, creates templates by preventing PDMS from covering the master template, as can be seen in Figure 2. The end result of this process is a PDMS model with holes in the pattern of the master. Different methods can be used to prevent PDMS from covering the master features, such as placing plates against the master following PDMS addition, or adding the PDMS to a thickness smaller than that of the master features (Li et al 2003).

Microfluidic patterning, the last of the soft lithographic techniques, utilizes a PDMS mold to create microchannels against a substrate. These microchannels can then be used to pattern fluid materials onto a substrate (Li et al 2003). This technique has been utilized for the patterning of cells in tissue engineering applications (Tan and Desai 2003). One important feature of these microchannels is their ability to maintain separate fluid streams through a single channel because of laminar flow (Andersson and van den Berg 2004). This characteristic can be utilized for the study of cellular response to the stimuli of different materials.

## Film deposition

The application or growth of layers of materials, or films, on the surface of microstructures is a common procedure of microfabrication. Films can play a structural or functional role in the design. For example, they may be used during microfabrication as sacrificial or masking layers that protect the base material from etching, or even as electrical components for a microfabricated device. Numerous types of materials are used for the generation of films. Among these, the most commonly used are plastics, silicon-containing compounds, metals, and biomolecules (Voldman et al 1999).

## Etching

Etching is a process that aims to create topographical features on a surface by selective removal of material through physical or chemical means. Etching can be isotropic if it proceeds equally in all directions or anisotropic if it proceeds in one specified direction. Figure 3 depicts these two etching mechanisms. As shown in Figure 3A, isotropic etching occurs not only in the direction of depth, but also laterally, and results in a curved profile. Anisotropic etching, shown in both Figures 3B and 3C, occurs in only in one direction, usually selectively increasing the depth of the cavity.

The mechanisms used for etching utilize liquid chemicals or gaseous physico-chemical processes. These two methods are more commonly known as wet etching or dry etching, respectively (Li et al 2003). As shown in Figures 3B and 3C, dry anisotropic etching results in a flat profile, while wet anisotropic etching results in cavities with inclined side-walls. The characteristic slanted profile of wet anisotropic etching is a result of the interaction of the etching reagent with the crystalline structure of the material being etched. The crystal structure determines the rate of etching that occurs at each crystal plane. For most applications, the flat profile of dry anisotropic etching is adequate. Reactive ion

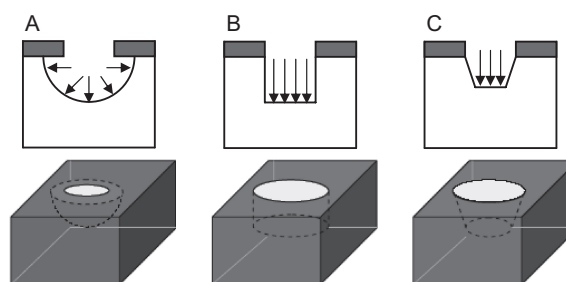

**Figure 3** Etching profiles generated with (A) isotropic etching, (B) dry anisotropic etching, and (C) wet anisotropic etching.

etching, which utilizes oxygen or fluorine plasma, has also been extensively used.

## Bonding

Reversible and irreversible bonds can be formed between microstructures to form tight seals or to obtain desired structures. There are numerous bonding methods available that are specific for the material of interest. For example, irreversible anodic bonding is possible between a silicone substrate and a non-pure glass film (Voldman et al 1999). The formation of this bond requires exposure of the system to temperatures in the order of 400°C, high pressure, and an electric field. Fusion bonding, on the other hand, consists of

the annealing of two surfaces at high temperatures ( $\sim 1000^\circ\text{C}$ ) (Voldman et al 1999).

Bonding of polymers can be carried out through heating above the glass transition temperature and applying pressure to seal the structures, through laser welding, or ultrasonic welding (Becker 2000). In addition, adhesives can also be utilized to bind two materials. However, the addition of intermediate layers will affect the properties of the system and must be taken into account.

## Nanofabrication techniques

Nanofabrication utilizes principles similar to those of microfabrication for the generation of patterns or devices at the nanoscale level, ie, of sizes ranging from 1 to 100 nm. Some authors consider sizes of up to 1000 nm to be within the realm of nanostructures. Various microfabrication techniques have been utilized to achieve features within this range. Soft lithographic techniques, for example, have been employed for the production of features with a resolution of less than 200 nm through the use of materials stiffer than PDMS for the fabrication of the stamp (Chen and Pepin 2001). Features of less than 40 nm have been produced with conventional photolithography utilizing light of 193-nm wavelength (Gates et al 2005). In addition, a number of special lithographic techniques have been developed to accomplish this miniaturization and will be discussed in the following sections.

### Electron beam lithography

Electron beam lithography is the principal nanofabrication technique used to create features at the nanoscale level on a material. This technique utilizes an electron beam to scan a material and form the desired pattern. Magnetic lenses are used to focus the beam. Commonly used electron sources are thermoionic emitters and thermal field emitters which have outputs in the range of 1 to 200 keV, but are most commonly used in the range of 50–100 keV (Chen and Pepin 2001). The resolution obtained through this type of lithography is greatly influenced by the beam spot size. Specimen position and beam characteristics are electronically controlled to achieve the desired nanoscale resolution. Various researchers have demonstrated resolutions on the order of less than 10 nm. Chen et al (1996) demonstrated the feasibility of producing 5 to 7 nm-wide etched lines on a silicon substrate by patterning a polymethylmethacrylate photoresist with an electron beam of less than 5 nm in diameter at a voltage of 80 kV (Chen and Ahmed 1993). The main drawback of electron beam lithography is the cost associated with purchase and maintenance of the system (Gates et al 2005).

### Focused ion beam lithography

This type of lithographic technique utilizes ions in place of electrons to pattern a resist. Ions are generated from a liquid metallic tip, containing elements such as gallium, “filtered” to allow only one type of ion to interact with the resist, and focused on the material surface with electrostatic lenses (Chen and Pepin 2001). Common operational energy levels are in the range of 10 to 200 keV. Focused ion beam lithography can also be used to pattern features directly to a substrate – without the need for a photomask – by either selective material removal or deposition (Gates et al 2005). Compared with electron ion beam lithography, the patterning speed offered by this technique is significantly slower because of lower achievable ion current density, when compared with that of electrons. Common feature resolutions are in the range of 20 nm, with a minimal 5 nm lateral feature size (Gates et al 2005).

### Colloid monolayer lithography

This lithographic method utilizes self-organized one- or two-dimensional colloidal systems as layers for nanofabrication. This technique is an economical alternative to the common electron or ionic lithographic methods, but is still able to produce patterns at the nanoscale. Colloidal monolayers can be generated through a number of self-assembly processes. For example, colloidal particles can be deposited on the surface of a substrate in solution prior to solvent evaporation, through spin coating, or through electrophoresis (Burmeister et al 1999).

If the size and geometry of the colloidal particles is precisely controlled, it is in theory possible to also control the spatial distribution of the colloids. For example, monodispersed spherical particles can be close-packed into hexagonally arranged monolayers, ie the conformation of highest density for this geometry (Burmeister et al 1999). Nonetheless, a number of parameters including colloid concentration, solvent evaporation rate, wetting characteristics of the substrate, and competition with multiple-layer formation influence the resulting array. It has been reported that the achievable resolution offered by this technique, when the colloidal monolayer is utilized as a resist, can be as low as 5 nm in all three dimensions (Curtis and Wilkinson 2001).

These colloid monolayers can be used as a protective barrier against etching and, consequently, transfer their semi-random distribution pattern to the substrate material (Curtis and Wilkinson 2001). More specifically, these etch masks would result in the removal of the substrate material located



below the colloid interstices. The same analogy can be made for applications in selective film deposition. Depending on the application, the colloidal particles can be either removed or left in place.

Another application of colloidal monolayers has been recently reported by the group of Dr. Saochen Chen at the University of Texas at Austin. In their design, colloidal silica spheres were deposited on the surface of a poly ( $\epsilon$ -caprolactone) film. After self-arrangement of the spheres, a laser beam was used to irradiate the samples. The spheres, which have diameters larger than the wavelength of the light, act as lenses, thus intensifying the effect of the laser beam on the substrate material (Lu and Chen 2004). Upon disappearance of the spheres due to laser action, holes arranged in the original sphere pattern are left behind. Thus, this technique can be used for high throughput patterning of *nano*holes.

## Molecular self assembly

Molecular self assembly is an alternative to lithographic techniques for the fabrication of features and structures at the nanometer scale. It is based on thermodynamically favored interactions of molecules such as peptides, proteins, and DNA, and other organic or inorganic molecules (Rajagopal and Schneider 2004). Molecules are spontaneously brought together to energetically stable conformations favored by noncovalent forces including hydrophobic, van der Waals, and electrostatic interactions, as well as hydrogen bonding. This technique has a number of advantages including the ability to fabricate three-dimensional structures and the potential for molecular control of the material (Rajadopal and Schneider 2004). Molecular self assembly is able to control pattern formation to the sub-nanometer scale. Self assembly of monolayers of amphiphilic peptide  $\beta$ -hairpins was shown to result in organized structures containing 2.5 nm hairpins spaced by less than 0.3 nm (Rajagopal and Schneider 2004).

Layer-by-layer assembly, one of the self assembly methods, is based on the consecutive deposition of multiple thin polyion films from solution utilizing the electrostatic attraction that develops between oppositely charged molecules as a driving force for assembly (Decher 1997). Time for adsorption of polyions onto surfaces ranges from minutes to hours depending on factors such as polyion type and concentration. Intermediate washes between sequential depositions are performed to avoid contamination from previous solutions. This technique has been widely accepted because it permits the use of numerous materials, including

biomolecules such as proteins (Decher 1997; Lvov et al 1998) and DNA (Taton et al 2000). This technique also provides great control over the film structure, thickness, and function. In addition, because film formation occurs by adsorption of polyanions or polycations from solution, the number of possible morphologies and sizes are only limited by those of the substrate to be coated.

## Electrically induced nanopatterning

Electrically induced nanopatterning techniques utilize electrostatic interactions between a thin dielectric material liquid film and an electric field gradient to produce lateral patterns and structures at the nanometer scale (Schäffer et al 2000). The nanofabrication system is analogous to a capacitor because it consists of two parallel electrodes separated by an air gap of less than a micron, as shown in Figure 4. A polymer, such as polystyrene, is applied to one of the electrodes by spin coating. Upon exposure to high temperature (above the glass transition temperature of the polymer) and to an electric field generated by the voltage across the electrodes, electrostatic forces develop and result in the destabilization of the polymeric film. Since the instabilities have a defined periodic undulation pattern, this system ultimately results in the formation of polymeric columns at the location of the peaks of the polymer “wave”, ie, those locations with the highest polymer thickness or smallest air gap between the polymer and the top electrode (Schäffer et al 2000, Liu et al 2003). Lateral column density and order can be altered by changing parameters such as the initial polymer film thickness, or the inter-electrode spacing (Schäffer et al 2000).

If in addition the electrode opposite to the polymer possesses microstructured patterns, the instabilities will first develop at the locations where the distance between the electrodes is minimal because of the increased electrostatic driving force. The result of these instabilities is that the polymer extends across the air gap toward the opposite electrode, thus generating nanometer scale “columns” in the specific pattern of the top electrode (Schäffer et al 2000), as can be seen in Figure 4. These columns are then solidified by cooling below the polymer’s glass transition temperature. Pattern reproductions with features of 140 nm were reported, but the authors suggest that generation of features of less than 100 nm is feasible.

This technique has further been utilized to generate porous templates for the fabrication of nanowire arrays with very high densities (Thurn-Albrecht et al 2000). This system utilized a film of the diblock copolymer of polystyrene (PS) and polymethylmethacrylate (PMMA) that self-assemble into

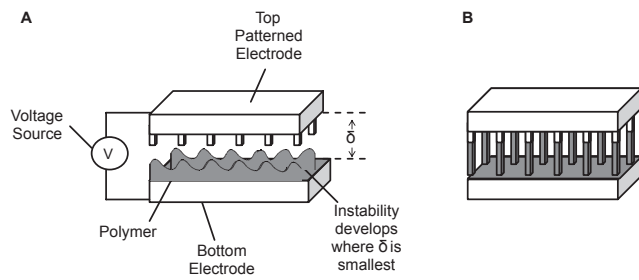

**Figure 4** Schematic of electrically-induced micropatterning process. (A) The system utilized for electrically induced micropatterning consists of two electrodes separated by an air gap of thickness  $\delta$ . A thin film of a polymer to be molded is applied to the bottom electrode. Upon exposure of an external magnetic field, electrostatic forces surpass surface tension forces, and instabilities develop on the polymer at the sites where  $\delta$  is smallest. (B) Columns formed at the sites of the major instabilities mimic the pattern of the top electrode. Based on a figure from Schäffer et al (2000).

arrays of PMMA cylinders surrounded by a PS matrix. This film was coated onto a bottom electrode, and exposed to an electric field. The material migrated toward the top electrode maintaining the self-assembled domains and, after cooling, was subjected to deep ultraviolet irradiation to crosslink the PS matrix and degrade the PMMA columns, which were then removed to form the porous template. Electroplating was later used to fill the nanopores with metals to fabricate nanowire arrays.

## Rapid prototyping

Rapid prototyping combines various nanofabrication techniques for the generation of complex geometrical patterns, multi-layered structures, and structures with chemical functionality (Fan et al 2000; Lu and Chen 2004). This technique offers advantages over common lithographic methods such as resolution of features below 100 nm, the ability to include diverse functionalities to the materials, and most importantly, the reduction of fabrication time from hours to seconds (Fan et al 2000). In general, computer assisted design (CAD) is utilized to control the fabrication process. Some of the fabrication methods that are utilized in rapid prototyping include direct deposition, three-dimensional printing, selective laser sintering, and laser stereolithography (Lu and Chen 2004; Yeong et al 2004). These techniques generate micro and nano-structures in a layer-by-layer approach. Rapid prototyping techniques have been studied for the fabrication of scaffolds for tissue engineering (Yeong et al 2004).

The utilization of rapid prototyping techniques was illustrated by a collaborating group from the University of Mexico and Sandia National Laboratories (Fan et al 2000). In this work, evaporation-induced self assembly, pen lithography, ink-jet printing and dip-coating techniques

were used for rapid fabrication of functional structures. The systems fabricated incorporated highly organized two- and three-dimensional arrangements of monodispersed pores, which could also be patterned for the formation of larger structures. In addition, different molecules were successfully added for functionality; some of the molecules utilized included mercaptopropyltrimethoxysilanes for noble metal coupling, and aminopropyltrimethoxysilanes for metal, dye, or bioactive molecule coupling (Fan et al 2000).

## X-ray lithography

This technique employs electromagnetic radiation of wavelengths in the range of 0.5 to 4 nm, commonly known as soft X-rays, for pattern transfer from a mask to a substrate material (Chen and Pepin 2001). Common sources of soft X-rays are synchrotrons or laser-induced plasma generators (Chen and Pepin 2001). X-ray masks are usually in the order of a few microns in thickness, and are usually composed of silicon carbide. Absorber patterns, analogous to the opaque regions of a photolithographic mask, are created with heavy metals such as gold, tungsten or tantalum (Chen and Pepin 2001).

In this technique, it is possible to perform lithography with a mask-to-wafer distance of several microns. However, larger gap distances proportionally reduce the achievable resolution (Chen and Rousseaux 1996; Chen and Pepin 2001). Additional parameters that influence the resolution offered by this technique are Fresnel diffraction, also known as near-field diffraction, and photoelectron diffusion into resist films, or photoelectron blur (Chen and Rousseaux 1996; Chen and Pepin 2001). Unfortunately, the Fresnel diffraction is proportional to the wavelength of energy used, while the photoelectron blur is inversely proportional. Consequently, to achieve patterns with small resolutions it is necessary to balance these two variables. Resolutions of less than 30 nm have been reported (Chen and Pepin 2001).

## Ion projection lithography

Ion projection lithography is based on the exposure of a wafer to hydrogen or helium ions (Chen and Pepin 2001). As in photolithography, ion projection lithography uses a mask to prevent exposure of part of the substrate to ions. In this case, however, the masks contain an ion absorbing material that prevents ion projection to the substrate underneath the absorbing pattern. Common ion energies range from 70 to 150 keV (Chen and Pepin 2001). Fabricated features of the order of 50 nm have been reported (Hirscher et al 2002).

## Applications

Micro- and nanofabrication techniques have enabled the scientific and medical community to expand the applications of already-existing devices through miniaturization, and to create completely new devices with use of the increased control of size, morphology, topology, and functionality offered by these techniques. These novel micro- and nanodevices have been able to contribute immensely to the fields of cell biology, molecular biotechnology, and medicine. It is now possible to study the interactions of biomaterials with biological systems at the cellular and molecular scale, and to design new synthetic systems that are able to alter physiological responses by capitalizing on these findings. Applications of micro and nanodevices in the medical and pharmaceutical field are the focus of this section.

### Drug delivery devices

Micro- and nanofabrication techniques offer a range of possibilities for the preparation of peptide, protein, drug, or gene delivery devices. The ability to control the size, architecture, topography, and functionality of drug delivery vehicles could result in the fabrication of systems that behave in highly predictable manner both *in vitro* and *in vivo*, thus surpassing the capabilities of current drug delivery systems.

### Injectable micro- and nanodevices

The fabrication of injectable self-assembled micro reservoirs for controlled drug delivery was recently reported (Pizzi et al 2004). The design of these micro reservoirs consists of metallic cylindrical containers within which the drug was loaded. The metallic cylinders, made of biocompatible metals such as titanium or gold, were capped with degradable or non-degradable temperature sensitive polymeric membranes on both ends. These membranes could either degrade or become more permeable at high temperatures. Drug release could then be controlled externally through the application of electromagnetic radiation at the site of pathology. Therapeutic effect was a result of the synergistic combination of drug delivery at the site of pathology, and heating of the metallic walls of the micro reservoirs above viable temperatures upon application of the electromagnetic radiation. Microfabrication of this system is achieved through deposition of two metal layers onto a flat silicon substrate and sacrificial layer by thermal evaporation deposition. Drugs are immobilized onto the exposed metallic surface either chemically or physically. Photolithography and wet etching techniques are then employed to form a large number of independent squared elements. Upon etching of the sacrificial layer between the

silicon substrate and the metal layers, the internal stress on the metal causes it to roll into cylindrical configuration. Cylinders as small as 1.5 microns in diameter and 5 microns in length, with walls of tens of nm in thickness were reported.

Multilayered nanoparticles prepared by atom-by-atom or layer-by-layer self assembly for the delivery of drugs or genes have been developed (Prow et al 2004). These systems offer the possibility to combine multiple sequential functional layers that guide the particles through the drug delivery process one layer at a time. For example, sequential layers can be loaded with targeting molecules, membrane entrance molecules, intracellular targeting molecules, and active agents such as drugs and genes for targeted intracellular delivery (Prow et al 2004).

### Gene delivery with micro and nano-machined devices

A number of micro and nanodevices have been used for the delivery of genes to target cells. One such system utilizes "micromechanical piercing" or microprobe elements to deliver genes coated onto their surface through cell penetration (Reed et al 1998). Microprobes of 80 microns in height and with a sharp point of less than 200 nm in diameter were reported. Successful expression of genes delivered with microprobes was demonstrated in plant, animal, and mammalian cells (Reed et al 1998; Hashmi et al 1995). This system as described is only practical as a research tool for the transfection of cell monolayers; however, application of the concept for *in vivo* therapeutic purposes is being investigated.

### Stents for drug delivery

Reed and colleagues developed microfabricated intravascular stents for the treatment of restenosis (Reed et al 1998). The design is targeted at increasing the efficacy of pharmaceutical prevention of restenosis in comparison to local administration regimes that are unable to cross the internal elastic lamina and compressed plaque that are present in pathological vessels. These stents incorporate microprobes, which upon catheter-based localized deployment are able to perforate compressed plaque and internal elastic lamina, and deliver anti-restenosis agents or therapeutic genes, which are previously coated onto the microprobe surfaces, directly into coronary tissue. Fabrication of microprobe arrays for *ex vivo* study of barrier penetration in rabbit models was carried out through oxidation, photolithography and anisotropic etching of a silicon substrate (Reed et al 1998), techniques that result in planar structures. In order for this system to be feasible for



in vivo applications, the microprobe-containing stents require cylindrical geometry and the ability for deformation during balloon-based inflation (Reed et al 1998). The authors discuss the use novel anodic oxide microfabrication to prepare structures with high aspect ratio which could be used to solve some of these problems (Reed et al 1998).

### Microneedles for transdermal drug delivery

Microneedles have been developed for transdermal administration of proteins, drugs or genes with therapeutic purposes. Transdermal administration of active agents offers advantages when compared to intravenous or oral delivery routes. Intravenous administration is associated with low patient compliance because of pain caused by the injection. Oral drug delivery, on the other hand, is hindered by the degradation of the active agent in the gastro-intestinal track, low bioavailability because of the difficulties associated with intestinal absorption, and the sequestration of much of the drug upon absorption by the liver because of the first pass effect (Lee and Yamamoto 1989). These problems are most important when the active agent is a biomolecule such as a protein or DNA. Current transdermal delivery systems, however, achieve low bioavailability because of the low permeability of the *stratum corneum*, a layer of dead cells of 10–15  $\mu\text{m}$  in thickness that acts as a barrier. Numerous chemical and physical methods have been attempted with the purpose of increasing skin permeability for drug delivery purposes, including chemical enhancers, iontophoresis, electroporation, and ultrasound permeabilization (Bommannan et al 1992; Fang et al 1998; Lombry et al 2000; Pillai and Panchagnula 2003; Kalia et al 2004). Microneedles offer an alternative to conventional transdermal delivery and to permeabilization techniques because they act as channels that transport the drug across the *stratum corneum* barrier into the deeper tissue (dermis) where it can enter the systemic circulation. In addition, by careful control of the microneedle mechanical strength and length, it is possible to deliver drugs across the dermal barrier while evading the nerves, thus resulting in painless administration (Henry et al 1998; Kaushik et al 2001; Tao and Desai 2003).

Microneedles have been fabricated out of a range of materials including silicon, metals, polymers, and glass (McAllister et al 2003). Reactive ion etching has been widely used for the production of solid and hollow silicon microneedles (Henry et al 1998; McAllister et al 2003). Here, solid silicon microneedle arrays were produced by exposing a substrate covered by a chromium mask

patterned into dots of fluorine and oxygen plasma to etch the uncovered surfaces in such a way that microneedles are formed on the regions protected by the mask (Henry et al 1998). Hollow silicon microneedles are prepared by first etching a silicon substrate to form holes or conduits, followed by the previously described procedure to form the microneedle body (McAllister et al 2003). Micromolding techniques, in conjunction with electrodeposition or microinjection molding have been used for the fabrication of metal or polymer microneedles, respectively (McAllister et al 2003). Microneedles with various tip geometries were also reported.

As a proof-of-concept study, solid silicon microneedles of 150  $\mu\text{m}$  in height and less than 1  $\mu\text{m}$  in tip radius of curvature were tested on human epidermis ex vivo. Results showed that microneedle arrays produced by this method could be easily inserted, removed, and reinserted from the skin without significant damage, and resulted in up to 25 000-fold increase in permeability of calcein as a model drug (Henry et al 1998). Later ex vivo studies on human epidermis showed that the permeability to calcein, insulin, bovine serum albumin, and even polystyrene microspheres of 50  $\mu\text{m}$  diameter was increased by more than one or two orders of magnitude when solid microneedles were either inserted, or inserted and removed, respectively (McAllister et al 2003). In vitro studies on DU145 cells showed cells could uptake calcein administered with solid microneedles with only about 10% cell mortality (McAllister et al 2003). Finally, in vivo studies of transdermal delivery with hollow microneedles in diabetic hairless rats showed that microinjection of insulin resulted in a statistically significant reduction of the blood sugar level for a period of 5 hours. In addition, in vivo use of solid microneedle arrays on human volunteers suggested that application was not painful and did not cause irritation (Henry et al 1998).

Different microneedle designs have been utilized by other groups for the delivery of the antisense oligonucleotides (Lin et al 2001), proteins (Matriano et al 2002), and plasmid DNA (Mikszta et al 2002; Chabri et al 2004). The fabrication of biodegradable microneedles has also been proposed (Park et al 2005). Figure 5 shows examples of solid silicon microneedles fabricated by reactive ion etching.

Recently, emphasis has been placed on the fabrication and utilization of devices for enhanced microneedle drug delivery. For example, Zahn and colleagues have developed an on-chip planar positive displacement pump for portable continuous drug delivery with microfabrication techniques (Zahn et al 2004).

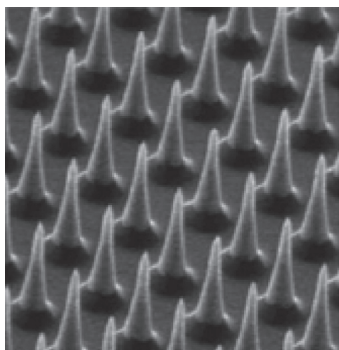

**Figure 5** Scanning electron microscopy image of relatively short solid silicon microneedles (25  $\mu\text{m}$  in height) prepared by reactive ion etching. These nanoparticles were designed for cutaneous gene delivery. Reproduced with permission from McAllister D, Wang P, Davis S, et al. 2003. Microfabricated needles for transdermal delivery of macromolecules and nanoparticles: fabrication methods and transport studies. *Proc Natl Acad Sci U S A*, 100:13755-60. Copyright © 2003 National Academy of Sciences, U.S.A.

### Implantable microfabricated drug delivery chips

Implantable microchips have been developed for on-demand pulsatile release of a number of different drugs in varied doses by the Langer group (Santini et al 1999; Langer and Peppas 2003). The design consists of the microfabrication of reservoirs within silicon substrates in which the drug is immobilized in either liquid or solid form (Santini et al 1999). These reservoirs are covered by a membrane of a material that can dissolve upon exposure to an electrochemical stimulus, such as gold. The microchip contains a cathode made of silicon nitride or silicon dioxide (Santini et al 1999). An electrical potential can be established between this cathode and one of the reservoir membranes which act as anodes. This potential triggers dissolution of the membrane, and results in the pulsatile release of the drug.

The implantable microreservoirs were generated by sequential microfabrication techniques including UV photolithography, chemical vapor deposition, electron beam evaporation and reactive ion etching (Santini et al 1999). The model microchips had a size of 17 mm on each side, and contained approximately 1000 reservoirs, each of which could contain a volume of up to 25 nL (Santini et al 1999).

More recently, a biodegradable microchip system fabricated from poly(lactic-co-glycolic acid)-based polymers was developed for long term pulsatile delivery of drugs (Richards et al 2003). Specifically, the main body of the device which contains reservoirs for drugs was made from poly(L-lactic acid) (PLLA), while the membranes covering these reservoirs were prepared from the fast-degrading polymer poly(D,L-lactic-co-glycolic acid) (PLGA). Using PLGA of different molecular weight for membrane preparation, they were able to show release of dextran,

heparin, and human growth hormone at different time intervals. Fabrication of these implantable devices utilized compression-molding for generation of the reservoirs on a PLLA disk, and microinjection for generation of reservoir membranes and drug filling (Richards et al 2003). Each 11-mm device had 36 reservoirs with a capacity of more than 120 nL each.

Low and colleagues have also developed responsive, reversible polymeric valves based on hydrogel actuators for microchip delivery of drugs in response to physiological changes (Low et al 2000). Such system would deliver active agents only when needed, thus avoiding unnecessary or possibly hazardous release of drugs which could occur from ‘pre-programmed’ microchips, such as those described above.

### Microfabricated bio- and muco-adhesive systems

Various alternative techniques have been investigated for improved oral delivery of drugs and biomolecules which currently offers only limited bioavailability as a result of the properties of the gastro intestinal track: low stomach pH and presence of proteases that degrade active agents, and poor intestinal absorption of macromolecules. Bio- and muco-adhesive systems offer the possibility to increase the residence time of drugs or drug carriers at the site of absorption, thus increasing the possibility that these drugs are able to enter the systemic circulation and exert a therapeutic effect. Micro- and nanofabrication offer the opportunity to design and produce oral drug delivery systems with high degree of functionality for bioadhesive purposes.

One such system utilizes poly(methacrylate) microparticles for bioadhesion. These microparticles were fabricated by lithography and reactive ion etching (Tao and Desai 2003), and were surface modified with amine groups to which biological molecules, such as avidin-lectin complexes, could be attached. Lectins were chosen because they are known to bind glycoconjugates on cell surfaces with great affinity. The microparticle square morphology and size (150  $\mu\text{m}$  wide by 3  $\mu\text{m}$  in thickness) were chosen in order to maximize the surface area in contact with the intestinal walls. This system was found to significantly increase binding to Caco-2 monolayers.

Other groups have proposed the use of micro- and nanofabrication techniques for the creation of patterned mucoadhesive structures based on the interactions between mucin, ie, the main organic component of intestinal mucus, and hydrophilic polymers (Kim and Peppas 2003;

Peppas and Huang 2004). Lithographic photopolymerization of hydrogels onto silicon substrates was proposed for these systems.

### Micro and nanofabricated biosensors

Sensors consist of devices that detect and/or measure a specific compound or condition in their environment, and generate a corresponding output through the action of a transducer. Depending on the design, micro- and nanosensors are able to identify changes in pressure, temperature, ionic strength, or concentration or a target molecule, just like their macro-metric counterparts.

Microcantilevers have been shown in the past to work as very sensitive transducers for sensing applications. Their function is based on the generation of surface stresses, and a subsequent bending of the cantilever in response to changes in environmental conditions, or upon binding of a target molecule.

Microcantilevers functionalized with pH-sensitive hydrogels were recently developed by the group of Dr Nicholas Peppas (Bashir et al 2002; Hilt et al 2003). The system shown in Figure 6 is an example of these environmentally sensitive cantilevers. These pH-sensitive hydrogels, in this case prepared by selective crosslinking of poly(methacrylic acid) and poly(ethylene glycol) dimethacrylate, exhibit a swelling behavior that responds to changes in the pH of the surrounding medium. Hydrogels were patterned by photolithography onto micro-machined silicon cantilevers by selective UV free-radical polymerization. An organosilane compound was used to form covalent bonds between the silicon substrate and the hydrogel polymers. Upon pH changes, the resulting hydrogel swelling creates surface stress

on the cantilever that results in a specific degree of bending. The sensitivity of these systems was observed to be of up to 1 nm per  $5 \times 10^{-5}$  pH units, with maximum sensitivity between pH 5.9 and 6.5 (Bashir et al 2002; Hilt et al 2003). Lei et al reported a similar system in which hydrogels were patterned onto microcantilevers through photolithography and dry etching, instead of through polymerization at the surface of the microcantilever (Lei et al 2004). This alternative method avoids the use of photoinitiators that could possibly impose limitations on the in vivo use of these systems.

A similar system was designed for sensing of glucose through the immobilization of the enzyme glucose oxidase (GOx) onto gold-coated silicon cantilevers. Enzymatic reaction of glucose in solution with the immobilized GOx results in a measurable cantilever deflection that is representative of the concentration of glucose in the medium (Pei et al 2004). This system was shown to be effective over a wide range of glucose concentrations up to 20 mM.

Biosensors based on configurational biomimetic imprinted hydrogels with biorecognitive properties have also been proposed (Byrne et al 2002; Hilt and Byrne 2004). Three-dimensional biomimetic imprinted polymer networks are generated by self assembly of polymers and/or functional monomers around target molecules during the formation of the hydrogels. Self assembly is driven by thermodynamically favored chemical or biological interactions (except covalent bonding) between the target molecule and the hydrogel components. Upon removal of the target molecules from these hydrogels, cavities with biorecognitive properties are left behind. Applications of biomimetic materials include biosensors that are able to recognize a target molecule, and deliver drugs or remove unwanted compounds for therapeutic purposes (Hilt and Byrne 2004).

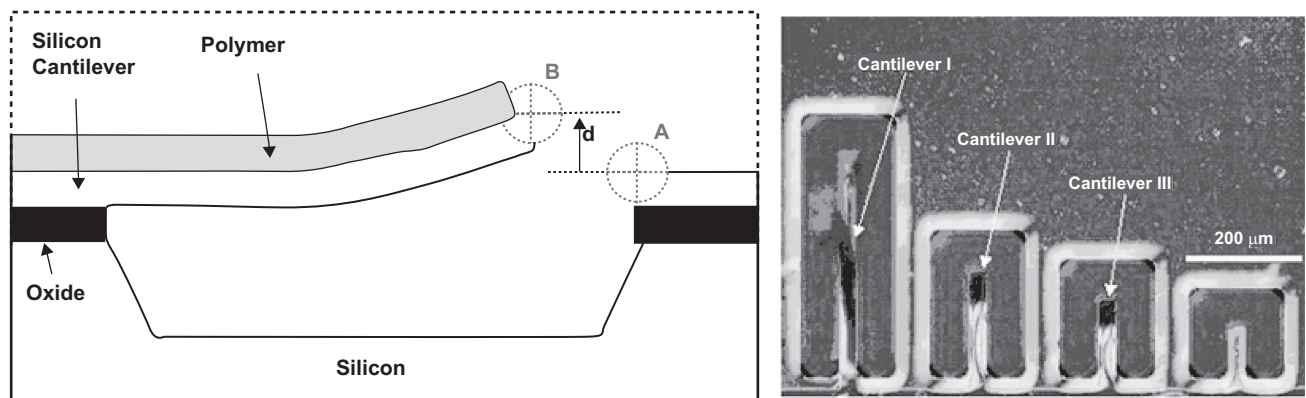

**Figure 6** Schematic (left) and image captured with a Microscope II in Nomarski mode (right) of silicon cantilevers patterned with photolithography with environmentally sensitive hydrogels. Swelling of the hydrogel as a result of pH changes results in pH-dependent deflection that can be quantified based on the differences of focus planes A and B. The thickness of the patterned hydrogels was determined to be of approximately 2.5  $\mu\text{m}$ . Unpublished images provided by Dr. Nicholas Peppas.

## Conclusions

Adaptation of micro- and nanofabrication techniques derived from the semiconductor industry has led to the creation of novel devices for use in the medical and pharmaceutical fields. These systems promise to offer improved characteristics including enhanced control of feature geometry, size and complexity, feasible mass production, portability, and miniaturization. In addition, because these techniques enable the production of devices at the cellular and sub-cellular levels, they open the doors to the creation of new strategies for the study and manipulation of molecules, cells, and tissues, thus providing new avenues for the investigation of pathological mechanisms and novel treatment options. This paper describes some of the main micro- and nanofabrication techniques that have been published in the literature and examples of how these techniques have revolutionized the fields of drug delivery and diagnostics.

## References

- Andersson H, van den Berg A. 2004. Microfabrication and microfluidics for tissue engineering: state of the art and future opportunities. *Lab on a Chip*, 4:98-103.
- Bashir R, Hilt J, Elibol O, et al. 2002. Micromechanical cantilever as an ultrasensitive pH microsensor. *Appl Phys Lett*, 81:3091-3.
- Becker H, Gärtner C. 2000. Polymer microfabrication methods for microfluidic analytical applications. *Electrophoresis*, 21:12-26.
- Blanchette JO, Kavimandan N, Peppas NA. 2004. Principles of transmucosal delivery of therapeutic agents. *Biomed Pharmacother*, 58:142-51.
- Bommannan D, Okuyama H, Stauffer P, et al. 1992. Sonophoresis. I. The use of high-frequency ultrasound to enhance transdermal drug delivery. *Pharm Res*, 9:559-64.
- Brannon-Peppas L, Blanchette JO. 2004. Nanoparticle and targeted systems for cancer therapy. *Adv Drug Deliv Rev*, 56:1649-59.
- Burmeister F, Badowsky W, Braun T, et al. 1999. Colloid monolayer lithography—a flexible approach for nanostructuring of surfaces. *Applied Surface Science*, 144-155:461-6.
- Byrne ME, Oral E, Hilt JZ, et al. 2002. Networks for recognition of biomolecules: molecular imprinting and micropatterning poly (ethylene glycol)-containing films. *Polymers for Advanced Technologies*, 13:798-816.
- Chabri F, Bouris K, Jones T, et al. 2004. Microfabricated silicon microneedles for nonviral cutaneous gene delivery. *Br J Dermatol*, 150:869-77.
- Chen W, Ahmed H. 1993. Fabrication of 5-7 nm wide etched lines in silicon using 100 keV electron-beam lithography and polymethylmethacrylate resist. *Appl Phys Lett*, 62:1499-501.
- Chen Y, Pepin A. 2001. Nanofabrication: conventional and nonconventional methods. *Electrophoresis*, 22:187-207.
- Chen Y, Rousseaux F, Haghiri-Gosnet A, et al. 1996. Proximity X-ray lithography as a quick replication technique in nanofabrication: recent progress and perspectives. *Microelectronic Engineering*, 30:191-4.
- Curtis A, Wilkinson C. 2001. Nanotechniques and approaches in biotechnology. *Trends Biotechnol*, 19:97-101.
- Decher G. 1997. Fuzzy nanoassemblies: toward layered polymeric multicomposites. *Science*, 277:1232-7.
- Fan H, Lu Y, Stump A, et al. 2000. Rapid prototyping of patterned functional structures. *Nature*, 405:56-60.
- Fang JY, Lin HH, Chen HI, et al. 1998. Development and evaluation on transdermal delivery of enoxacin via chemical enhancers and physical iontophoresis. *J Control Release*, 54:293-304.
- Gates BD, Xu Q, Stewart M, et al. 2005. New approaches to nanofabrication: molding, printing and other techniques. *Chem Rev*, 105:1171-96.
- Hashmi S, Ling P, Hashmi G, et al. 1995. Genetic transformation of nematodes using arrays of micromechanical piercing structures. *Biotechniques*, 19:766-70.
- Henry S, McAllister DV, Allen MG, et al. 1998. Microfabricated microneedles: a novel approach to transdermal drug delivery. *J Pharm Sci*, 87:922-5.
- Hilt J, Gupta A, Bashir R, et al. 2003. Ultrasensitive biomems sensors based on microcantilevers patterned with environmentally responsive hydrogels. *Biomed Microdevices*, 5:177-84.
- Hilt JZ, Byrne ME. 2004. Configurational biomimesis in drug delivery: molecular imprinting of biologically significant molecules. *Adv Drug Del Rev*, 56:1599-620.
- Hirscher S, Kummel M, Kirch O, et al. 2002. Ion projection lithography below 70 nm: tool performance and resist process. *Microelectronic Engineering*, 61-62:301-7.
- Kalia YN, Naik A, Garrison J, et al. 2004. Iontophoretic drug delivery. *Adv Drug Del Rev*, 56:619-58.
- Kaushik S, Hord AH, Denson DD, et al. 2001. Lack of pain associated with microfabricated microneedles. *Anesth Analg*, 92:502-4.
- Kim B, Peppas NA. 2003. Poly(ethylene glycol)-containing hydrogels for oral protein delivery applications. *Biomedical Microdevices*, 5:333-41.
- Langer R, Peppas NA. 2003. Advances in biomaterials, drug delivery, and bionanotechnology. *AIChE J*, 49:2990-3006.
- Lee VHL, Yamamoto A. 1989. Penetration and enzymatic barriers to peptide and protein absorption. *Adv Drug Del Rev*, 4:171-207.
- Lei M, Gu Y, Baldi A, et al. 2004. High-resolution technique for fabricating environmentally sensitive hydrogel microstructures. *Langmuir*, 20:8947-51.
- Li N, Tourovskaia A, Folch A. 2003. Biology on a chip: microfabrication for studying the behavior of cultured cells. *Crit Rev Biomed Eng*, 31:423-88.
- Lin W, Cormier M, Samiee A, et al. 2001. Transdermal delivery of antisense oligonucleotides with microprojection patch (macroflux) technology. *Pharm Res*, 18:1789-93.
- Liu T, Burger C, Chu B. 2003. Nanofabrication in polymer matrices. *Prog Colloid Polym Sci*, 28:5-26.
- Lombry C, Dujardin N, Pr at V. 2000. Transdermal delivery of macromolecules using skin electroporation. *Pharm Res*, 17:32-7.
- Low LM, Seetharaman S, He K-Q, et al. 2000. Microactuators toward microvalves for responsive controlled drug delivery. *Sens Actuators B Chem*, 67:149-60.
- Lu Y, Chen S. 2004. Micro and nano-fabrication of biodegradable polymers for drug delivery. *Adv Drug Del Rev*, 56:1621-33.
- Lvov YM, Lu Z, Schenkman JB, et al. 1998. Direct electrochemistry of myoglobin and cytochrome p450<sub>cam</sub> in alternate layer-by-layer films with DNA and other polyions. *J Am Chem Soc*, 120:4073-80.
- Matriano JA, Cormier M, Johnson J, et al. 2002. Macroflux microprojection array patch technology: a new and efficient approach for intracutaneous immunization. *Pharm Res*, 19:63-70.
- McAllister D, Wang P, Davis S, et al. 2003. Microfabricated needles for transdermal delivery of macromolecules and nanoparticles: fabrication methods and transport studies. *Proc Natl Acad Sci U S A*, 100:13755-60.
- Mikszta JA, Alarcon JB, Brittingham JM, et al. 2002. Improved genetic immunization via micromechanical disruption of skin-barrier function and targeted epidermal delivery. *Nat Med*, 8:415-19.
- Park JH, Allen MG, Prausnitz MR. 2005. Biodegradable polymer microneedles: fabrication, mechanics and transdermal drug delivery. *J Control Rel*, 104:51-66.
- Pei J, Tian F, Thundat T. 2004. Glucose biosensor based on the microcantilever. *Anal Chem*, 76:292-7.



- Peppas NA, Huang Y. 2004. Nanoscale technology of mucoadhesive interactions. *Adv Drug Del Rev*, 56:1675-87.
- Pillai O, Panchagnula R. 2003. Transdermal delivery of insulin from poloxamer gel: ex vivo and in vivo skin permeation studies in rat using iontophoresis and chemical enhancers. *J Control Rel*, 89:127-40.
- Pizzi M, De Martiis O, Grasso V. 2004. Fabrication of self assembled micro reservoirs for controlled drug release. *Biomed Microdevices*, 6:155-8.
- Prow TW, Kotov NA, Lvov YM, et al. 2004. Nanoparticles, molecular biosensors, and multispectral confocal microscopy. *Journal of Molecular Histology*, 35:555-64.
- Rajagopal K, Schneider J. 2004. Self-assembling peptides and proteins for nanotechnological applications. *Curr Opin Struct Biol*, 14:480-6.
- Reed ML, Wu C, Kneller J, et al. 1998. Micromechanical devices for intravascular drug delivery. *J Pharm Sci*, 87:1387-94.
- Richards Grayson AC, Choi IS, Tyler BM, et al. 2003. Multi-pulse drug delivery from a resorbable polymeric microchip device. *Nat Mat*, 2:767-72.
- Santini J, Cima M, Langer R. 1999. A controlled-release microchip. *Nature*, 397:335-8.
- Schäffer E, Thurn-Albrecht T, Russell TP, et al. 2000. Electrically induced structure formation and pattern transfer. *Nature*, 403:874-7.
- Seeman NC. 2003. DNA in a material world. *Nature*, 421:427-31.
- Tan W, Desai TA. 2003. Microfluidic patterning of cells in extracellular matrix biopolymers: effects of channel size, cell type, and matrix composition on pattern integrity. *Tissue Eng*, 9:255-67.
- Tao S, Desai T. 2003. Microfabricated drug delivery systems: from particles to pores. *Adv Drug Del Rev*, 55:315-28.
- Taton TA, Mucic RC, Mirkin CA, et al. 2000. The DNA-mediated formation of supramolecular mono- and multilayered nanoparticle structures. *J Am Chem Soc*, 122:6305-6.
- Thurn-Albrecht T, Schotter J, Kästle GA, et al. 2000. Ultrahigh-Density nanowire arrays grown in self-assembled diblock copolymer templates. *Science*, 290:2126-9.
- Voldman J, Gray ML, Schmidt MA. 1999. Microfabrication in biology and medicine. *Ann Rev Biomed Eng*, 1:401-25.
- Xia Y, Whitesides GM. 1998. Soft lithography. *Ann Rev Mat Sci*, 28:153-84.
- Yeong W-Y, Chua C-K, Leong K-F, et al. 2004. Rapid prototyping in tissue engineering: challenges and potential. *Trends Biotechnol*, 22:643-52.
- Yurke B, Mills AP, Blakey MI, et al. 2003. DNA fuel for free-running nanomachines. *Phys Rev Lett*, 90:118102.
- Zahn JD, Deshmukh A, Pisano AP, et al. 2004. Continuous on-chip micropumping for microneedle enhanced drug delivery. *Biomed Microdevices*, 6:183-90.