



Campylobacter upsaliensis isolated from dogs produces high titer of cytolethal distending toxin

Srinuan SOMROOP¹⁾, Noritoshi HATANAKA¹⁾, Sharda Prasad AWASTHI¹⁾, Kentaro OKUNO¹⁾, Masahiro ASAKURA¹⁾, Atsushi HINENOYA¹⁾ and Shinji YAMASAKI¹⁾*

¹⁾Graduate School of Life and Environmental Sciences, Osaka Prefecture University, Osaka 598-8531, Japan

ABSTRACT. Cytolethal distending toxin (CDT) consisting of CdtA, CdtB and CdtC has been reported to be a possible virulence factor of campylobacters including *Campylobacter upsaliensis*. In our previous study, the *cdtB* gene-based PCR-restriction fragment length polymorphism (RFLP) assay for detection and differentiation of 7 *Campylobacter* species yielded 3 different RFLP patterns (Cu-I to Cu-III). In this study, entire *cdt* (*Cucdt*) genes of each pattern were sequenced to see whether there are any differences in *cdt* genes, its amino acid sequences and biological activity of CuCDT. We found that all 3 representative strains harbor the entire *Cucdt* genes and homology between prototype and newly determined *Cucdt* genes was 94 to 98% with *cdtA*, 93 to 94% with *cdtB* and 92 to 93% with *cdtC*, while that between amino acids of CuCDT was 95 to 99% with CdtA, 97 to 98% with CdtB and 92 to 93% with CdtC. Furthermore, CDT activity produced by *C. upsaliensis* strains was examined by cytotoxicity assay with HeLa cells. Interestingly, *C. upsaliensis* produced 64 to 2,340 times higher CDT titer in comparison to other campylobacters did. In addition, Cu-III showed 64 times higher CDT titer than Cu-II, although CDT production level was almost the same by western blotting. These data suggest that CDT produced by *C. upsaliensis* might contribute more to human diseases in comparison to that produced by other campylobacters and Cu-III CDT seems to be more toxic to HeLa cells in comparison to Cu-I and Cu-II CDTs.

KEY WORDS: *Campylobacter upsaliensis*, cytolethal distending toxin, zoonotic pathogen

J. Vet. Med. Sci.
79(3): 683–691, 2017
doi: 10.1292/jvms.16-0654

Received: 28 December 2016
Accepted: 28 January 2017
Published online in J-STAGE:
16 February 2017

Several epidemiological studies have revealed that *C. upsaliensis* could be isolated from patients, particularly from children, with diarrhea [1, 9, 18, 29] and from humans suffering from extra-intestinal manifestations, such as sepsis [22], hemolytic-uremic syndrome [4], spontaneous abortion [11] and postinfectious polyneuropathy [8, 12]. *C. upsaliensis* is considered to be one of the predominant emerging campylobacters after *C. jejuni* and *C. coli* [18]. *C. upsaliensis* is commonly found in dogs and cats, regardless of whether the animals are sick or not [3, 7, 26]. Consequently, *C. upsaliensis* can cause diseases to human through healthy household pets [10, 11]. However, very little is known about pathogenic mechanisms and virulence factors of this organism.

Production of cytolethal distending toxin (CDT) and nucleotide sequence of *cdt* genes have been reported from various Gram-negative pathogenic bacteria including *C. upsaliensis* [5, 17, 21]. Thus, CDT may be a possible virulence factor of *C. upsaliensis*. Several studies have demonstrated that CDT is responsible for cytotoxicity, invasiveness and long-term gut colonization, and may play a role in intestinal diseases *in vivo* [6, 13, 25]. CDT is composed of 3 subunits, CdtA, CdtB and CdtC. CdtA and CdtC mediate toxin binding to the receptor on cell surface followed by delivery of CdtB possessing DNase I-like activity into the cytosol. Subsequently, CdtB enters nucleus and leads to DNA damage, resulting in phosphorylation of histone H2AX (γ H2AX), G₂/M cell cycle arrest, cell distention and eventually apoptotic cell death.

In our previous study, *cdtB* gene-based PCR-restriction fragment length polymorphism (RFLP) assay for detection and differentiation of *C. jejuni*, *C. coli*, *C. fetus*, *C. hyointestinalis*, *C. lari*, *C. helveticus* and *C. upsaliensis* was established [15]. In that study, however, 3 RFLP patterns, namely Cu-I, Cu-II and Cu-III, were obtained from 22 *C. upsaliensis* strains mostly isolated from dogs. Most of the *C. upsaliensis* strains including ATCC 43954 yielded expected RFLP pattern (Cu-I), while 2 additional RFLP patterns, Cu-II and Cu-III, were obtained from 4 and 2 *C. upsaliensis* strains of animal origins, respectively. Thus, we suspected that *C. upsaliensis* strains, which show different RFLP patterns, might possess different CDT variants with different characteristics.

*Correspondence to: Yamasaki, S., Graduate School of Life and Environmental Sciences, Osaka Prefecture University, 1-58, Rinkuourai-kita, Izumisano, Osaka 598-8531, Japan. e-mail: shinji@vet.osakafu-u.ac.jp

©2017 The Japanese Society of Veterinary Science



This is an open-access article distributed under the terms of the Creative Commons Attribution Non-Commercial No Derivatives (by-nc-nd) License. (CC-BY-NC-ND 4.0: <https://creativecommons.org/licenses/by-nc-nd/4.0/>)

In this study, the entire nucleotide sequence of *C. upsaliensis* *cdt* (*Cucdt*) gene cluster and CDT activity produced by filter sterilized bacterial sonic cell lysate of representative *C. upsaliensis* strains of each RFLP pattern were examined. Here, we show that *C. upsaliensis* yielded higher CDT titer than other campylobacters, and even among *C. upsaliensis* strains CDT produced by strain 99-1 which was typed Cu-III is more toxic to HeLa cells than that of strain 40-1 which was typed Cu-II, although toxin production level was nearly identical.

MATERIALS AND METHODS

Bacterial strains and growth conditions

C. upsaliensis strains, ATCC 43954, 40-1, 48-1, 99-1 and 102-1, examined previously [16] were used in this study. Recombinant *Escherichia coli* strain BL21 (DE3) with *cdt-II* (*Chcdt-II*) genes of *C. hyointestinalis* in TH-pET vector (rChCDT-II) [17] and *C. jejuni* strain K328 with 667 and 51 bp deleted regions in the *cdt* gene cluster [15], were used as positive and negative controls, respectively, for cytotoxicity assay. *Campylobacter* strains were grown on blood agar [blood base agar no. 2 (Oxoid Ltd., Basingstoke, U. K.)] supplemented with 5% (v/v) defibrinated horse blood (Nippon Bio-Supp. Center, Tokyo, Japan) under anaerobic condition (10% CO₂, 10% H₂ and 80% N₂) at 37°C for 48 hr. *E. coli* strains, JM109 and BL21 (DE3), were used as cloning and expression vectors, respectively, and they were grown aerobically in Luria-Bertani (LB; Becton, Dickinson and Co., Franklin Lakes, NJ, U.S.A.) agar at 37°C overnight. *E. coli* strains carrying a recombinant plasmid were grown in LB broth containing 30 µg/ml kanamycin (Nacalai Tesque Inc., Kyoto, Japan) at 37°C with vigorous shaking.

DNA preparation

Chromosomal DNA of *C. upsaliensis* strains, ATCC 43954, 40-1 and 99-1, was purified by using Isoplant DNA Extraction Kit (Nippon Gene Co., Ltd., Toyama, Japan).

Determination of entire *Cucdt* gene-sequence

Entire *Cucdt* gene sequences of *C. upsaliensis* strains, ATCC 43954, 40-1 and 99-1, were determined either by standard sequencing method or by genome walking as described previously [2] using primers summarized in Table S1. Synthetic primers were designed on the basis of obtained sequences including *cdtB* gene sequences of *C. upsaliensis* strains ATCC 43954 (accession number; AB872889.1), 40-1 (AB872895.1) and 99-1 (AB872904.1) reported by Kamei *et al.* [16], and genome walking was performed as described earlier with minor modification [2]. Briefly, 50 ng of genomic DNA was randomly extended with 0.4 µM random primer. PCR was performed in TaKaRa PCR thermal cycler (TaKaRa Bio Inc., Otsu, Japan) or Applied Biosystems GeneAmp PCR System 9700 (Thermo Fisher Scientific Inc., Waltham, MA, U.S.A.). Then, PCR amplification was performed with 0.4 µM of target primer. PCR products were purified by QIAquick PCR product purification kit (QIAGEN GmbH, Hilden, Germany), and sequencing was performed by the chain termination method with the BigDye terminator v1.1 cycle sequencing kit (Thermo Fisher Scientific Inc.) using an ABI PRISM 3130-Avant Genetic Analyzer (Thermo Fisher Scientific Inc.). The *Cucdt* gene sequences obtained in this study were analyzed using DNA Lasergene software package (DNASTAR Inc., Madison, WI, U.S.A.). Homology searches were performed using BLAST programs by National Center for Biotechnology Information (NCBI). Nucleotide sequence and amino acid sequence alignments were analyzed by ClustalW of MegAlign (DNASTAR Inc.).

Preparation of bacterial sonic cell lysate

Bacterial sonic cell lysate was prepared as described previously [17]. *Campylobacter* strains shown in Table 1 were cultured as described above, and recombinant *E. coli* strain BL21 (DE3) carrying the *Chcdt-II* genes in TH-pET vector was cultured in LB broth at 37°C until an optical density at 600 nm (OD₆₀₀) reached 0.3 to 0.6. Then, isopropyl-β-D-thiogalactopyranoside (IPTG) (Nacalai Tesque Inc.) was added to the culture as a final concentration of 0.1 mM and continued to culture for 18 hr at 18°C. Then, bacterial cells were harvested by centrifugation at 6,000 ×g at 4°C for 20 min and suspended in PBS (pH 7.4). The cell suspensions were adjusted to an OD₆₀₀ of 10 and sonicated on ice 3 times for 1 min duration and stored for 1 min using a handy sonicator (UR-20P; Tomy Seiko, Tokyo, Japan). The bacterial sonic cell lysates were clarified by centrifugation at 20,000 ×g at 4°C for 10 min, and supernatants were passed through a 0.22 µm cellulose acetate filter (Asahi glass Co., Ltd., Tokyo, Japan) for further cytotoxicity assay.

Eukaryotic cell culture

HeLa cells (American Type Culture Collection [ATCC]) were cultured in Eagle's minimum essential medium (MEM; Nissui Pharmaceutical Co., Ltd., Tokyo, Japan) supplemented with 5% fetal bovine serum (FBS; Thermo Fisher Scientific Inc.) at 37°C under 5% CO₂ in air. In addition, the medium was supplemented with 1% antibiotic cocktail of antibiotic-antimycotic (×100; Thermo Fisher Scientific Inc.) and 1% GlutaMax (×100; Thermo Fisher Scientific Inc.). FBS was heat inactivated at 56°C for 30 min before use.

Cytotoxicity assay

Filter sterilized bacterial sonic cell lysate was used for cytotoxicity on HeLa cells. The cells were seeded at the density of 5 × 10³ cells in 100 µl culture medium in a 96-well plate (Trueline, Nippon Genetics Co., Ltd., Tokyo, Japan) and cultured with 10 µl of 2-fold serially diluted filter sterilized bacterial sonic cell lysates with PBS at 37°C under 5% CO₂ in air for 72 hr. Then,

Table 1. Cytotoxicity of bacterial cell lysates of CDT-producing campylobacters

Bacterial species	Strain	Origin	Toxin titer ^{a)}
<i>C. upsaliensis</i>	ATCC 43954 (Cu-I) ^{b)}	Dog	8,192
	102-1 (Cu-I)	Dog	4,096
	40-1 (Cu-II)	Dog	1,024
	48-1 (Cu-II)	Dog	8,192
	99-1 (Cu-III)	Dog	65,536
<i>C. jejuni</i>	81-176	Clinical	128
	9813	Clinical	1,024
	ChB43	Chicken	128
<i>C. fetus</i>	ATCC 27374	Sheep	512
	C01-187	Clinical	1,024
	C02-150	Bovine	256
<i>C. hyointestinalis</i>	ATCC 35217	Swine	1,024
	022	Clinical	128
	130206 DCC11	Bovine	128
<i>C. lari</i>	JCM 2530	Herring gull	128
	84C-1	Clinical	128
	264	Mussel	128

a) The reciprocal of the highest dilution of filter sterilized bacterial cell lysate at which 50% of the monolayer cells showed morphological changes of enlargement and distension. b) The PCR-RFLP pattern which strains are belonging [16].

cells were stained with Giemsa solution by using Diff-quick (Sysmex, Kakogawa, Japan), and cytotoxicity was observed under a microscope. The 50% cytotoxicity dose (CD₅₀) was defined as the reciprocal of the highest dilution of filter sterilized bacterial sonic cell lysate at which 50% of the monolayer cells showed morphological changes of enlargement and distension.

Cell cycle analysis

HeLa cells were seeded at the density of 2.5×10^5 cells in 4 ml culture medium in a 25 cm² flask (Trueline, Nippon Genetics Co., Ltd.) and cultured with 100 μ l of filter sterilized bacterial sonic cell lysate at 37°C under 5% CO₂ in air. After 24 hr incubation, cells were collected by centrifugation at 1,000 \times g at 4°C for 5 min and fixed with 70% ethanol on ice for 2 hr. The cells were then collected and treated with 0.1% Triton X-100 in PBS at room temperature for 15 min. Subsequently, cells were collected, suspended in PBS containing 0.25 mg/ml of RNase A (Sigma-Aldrich, St. Louis, MO, U.S.A.) and incubated at 37°C for 15 min and further stained with propidium iodide (PI; 50 μ g/ml) at 4°C for 30 min under the dark condition. Flow cytometry analysis of DNA content of the cells was performed with a S3 cell sorter (Bio-Rad Laboratories Inc., Hercules, CA, U.S.A.), and 10,000 events were collected. Cell cycle analysis was performed by ProSort software (Bio-Rad Laboratories Inc.).

Genotoxicity assay

About 1.0×10^4 of HeLa cells in 200 μ l culture medium were seeded on a glass slide (8-well LabTek II Chamber slide system; Nalge Nunc, Rochester, NY, U.S.A.) and cultured with 10 μ l of filter sterilized bacterial sonic cell lysate at 37°C for 24 hr under 5% CO₂ in air. Subsequently, cells were fixed with 3.7% formaldehyde in PBS for 10 min, followed by treatment with 0.5% Triton X-100 for 20 min and 1.0% BSA in PBS for 1 hr at room temperature. γ H2AX in HeLa cells was stained with anti-phospho-histone-H2AX (Ser139) polyclonal antibody (Enzo Life Sciences, Inc., Farmingdale, NY, U.S.A.) at 37°C for 1 hr and Alexa Fluor 488-conjugated goat anti-mouse IgG antibody (Life Technologies, Carlsbad, CA, U.S.A.) at 37°C for 1 hr under dark condition, respectively. Intracellular F-actin was stained with Alexa Fluor 546-conjugated phalloidin (Life Technologies) at 37°C for 1 hr under dark condition. Fluorescence was observed under an epifluorescence DM2500 microscope (Leica Microsystems, Wetzlar, Germany).

Preparation of expression vector

CudtC gene was amplified from genomic DNA of *C. upsaliensis* strain ATCC 43954 by PCR using primer set 5'-ATATGAATTCTTCGCAGAAAATCCGGGC-3' and 5'-ATATAAGCTTTTATAAAACATTAGCCTT-3'. The sequences underlined represent the cleavage sites for *Eco*RI (GAATTC) and *Hind*III (AAGCTT), which were used for restriction sites of cloning. PCR mixtures contained 1 \times Q5 DNA polymerase buffer, 0.2 mM dNTP mixture, 0.5 mM each primer, 1 μ l DNA template and 1.25 U Q5 DNA polymerase (New England Biolabs Inc., Ipswich, MA, U.S.A.) in a 50 μ l reaction volume. The thermal cycling was as follows: 94°C for 30 sec, 55°C for 30 sec and 72°C for 30 sec for 35 cycles, with a final extension of 5 min. The PCR products were analyzed by electrophoresis on a 1.5% PrimeGel™ Agarose LE gel (TaKaRa Bio Inc.), and bands were visualized with ultraviolet (UV) light after staining with ethidium bromide (1 μ g/ml) and then purified using Wizard SV® Gel and PCR clean-up system (Promega Corporation, Madison, WI, U.S.A.). Purified PCR product and pET28a (+) plasmid (Novagen, Madison, CT, U.S.A.) were digested with *Eco*RI and *Hind*III according to the manufacturer's instructions (TaKaRa Bio Inc.), and

then, each digest was ligated with T4 DNA ligase (TaKaRa Bio Inc.) at 16°C overnight. Subsequently, the ligation mixture was transformed into *E. coli* strain JM109 using Gene Pulser II (Bio-Rad Laboratories Inc.). *E. coli* strain carrying the recombinant plasmid was selected on LB agar containing 30 µg/ml kanamycin and by PCR using the primer set T7 promoter and T7 terminator (Novagen). The insert was confirmed by sequencing. The recombinant plasmid DNA was then isolated from *E. coli* by using QIAGEN Plasmid Extraction kit (QIAGEN GmbH).

Expression of recombinant protein

The recombinant plasmid was transformed into *E. coli* strain BL21 (DE3), and the transformant was grown in LB broth containing 30 µg/ml kanamycin at 37°C with vigorous shaking. After OD₆₀₀ of the culture reached 0.3–0.6, IPTG (Nacalai Tesque Inc.) was added to a final concentration of 0.1 mM, and the bacteria were further cultured at 37°C for 3 hr with vigorous shaking. Bacterial cells were harvested by centrifugation at 6,000 × g at 4°C for 15 min and were further used for the purification of recombinant protein.

Purification of recombinant protein

The *E. coli* cells were suspended in 50 mM Tris-HCl buffer (pH 7.8) containing 500 mM NaCl and sonicated on ice using an Astrason ultrasonic processor (Heat System-Ultrasonics Inc., Melville, NY, U.S.A.). The bacterial sonic cell lysates were centrifuged at 48,000 × g at 4°C for 20 min. Recombinant CuCdtC with His₆-tag (rCuCdtC) was purified from inclusion bodies, and the purification procedure was adapted by Lee *et al.* [19]. Briefly, the inclusion bodies were washed twice with washing buffer (100 mM Tris-HCl buffer [pH 7.0], 5 mM ethylenediaminetetraacetic acid [EDTA], 5 mM dithiothreitol [DTT], 2 M urea and 3% Triton X-100). After centrifugation, the pellet was resuspended in solubilization buffer (50 mM Tris-HCl buffer [pH 7.8], 500 mM NaCl and 8 M urea). The suspension was further stirred at room temperature for at least 1 hr and then centrifuged at 48,000 × g at 4°C for 20 min. The solubilized recombinant protein was dialyzed against refolding buffer (50 mM Tris-HCl buffer [pH 7.8], 500 mM NaCl, 2 mM EDTA, 5 mM DTT and 10% glycerol) with gradient of urea concentration (4 to 0 M) and subsequently against 50 mM Tris-HCl buffer (pH 7.8) containing 500 mM NaCl and 10% glycerol. The protein suspension was centrifuged at 48,000 × g at 4°C for 20 min. Then, the supernatant was used for purifying the recombinant protein using Ni-Sepharose column (GE Healthcare, Little Chalfont, U.K.), and the recombinant protein was eluted with 50 mM Tris-HCl buffer (pH 7.8) containing 500 mM NaCl and 200 mM imidazole (Kishida Chemical Co., Ltd., Osaka, Japan). The purity of the recombinant protein was examined by SDS-PAGE using 15% gel. The protein concentration was quantified by Bradford assay (Bio-Rad Laboratories Inc.).

Preparation of rabbit antiserum

Antiserum against rCuCdtC was generated by immunizing an 8-week-old male New Zealand White rabbit (Oriental Yeast, Tokyo, Japan) with purified rCuCdtC. Briefly, 200 µg of purified rCuCdtC was injected into two sites each, subcutaneously into the shoulders and intramuscularly into the thighs, every week with complete Freund's adjuvant (Becton, Dickinson and Co.) for initial immunization and subsequently with incomplete Freund's adjuvant (Becton, Dickinson and Co.) for 6–8 weeks. After the last immunization, the rabbit was boosted intravenously with 1 µg of purified rCuCdtC. After 3–5 days, the rabbit was anesthetized with ketamine (35 mg/kg [body weight]) and xylazine (5 mg/kg [body weight]), blood was collected, and serum was obtained by centrifugation at 1,500 × g for 10 min. The titer of antiserum was determined by an Ouchterlony double gel diffusion test with 1 µg of rCuCdtC as described previously [31]. All animal experiments were performed according to the Guidelines for Animal Experimentation of Osaka Prefecture University and approved by the Animal Experiment Committee of Osaka Prefecture University.

Neutralization assay

Ten microliter of 2-fold serially diluted rabbit antiserum was mixed with equal volume of the CD₅₀ dose of filter sterilized bacterial sonic cell lysates. The suspension was further added to HeLa cells at the density of 5 × 10³ cells in 100 µl culture medium in a 96-well plate (Trueline, Nippon Genetics Co., Ltd.). Then, cells were cultured at 37°C under 5% CO₂ in air for 72 hr and stained with Giemsa solution by using Diff-quick (Sysmex). Cytotoxicity was determined as described above.

For cell cycle analysis, 2.5 × 10⁵ of HeLa cells in 4 ml culture medium were seeded in a 25 cm² flask (Trueline, Nippon Genetics Co., Ltd.) and cultured with 100 µl of the CD₅₀ dose of filter sterilized bacterial sonic cell lysates in the presence of equal volume of rabbit antiserum at 37°C under 5% CO₂ in air. After 24 hr incubation, cells were collected, and cell cycle analysis was performed as described above.

Southern hybridization assay

The *CucdtB* gene-probe was prepared from PCR product which was amplified by C-CdtBcom1 and C-CdtBcom2 primer set from *C. upsaliensis* strain ATCC 43954 and labeled with [α -³²P]dCTP (370 MBq/ml) using Multiprime DNA labeling system (GE Healthcare UK Ltd., Buckinghamshire, U.K.) as described previously [17]. Three microgram of genomic DNA of each *C. upsaliensis* strain (ATCC 43954, 40-1 and 99-1), *E. coli* strain C600 and *C. hyointestinalis* strain ATCC 35217 were digested with 50 U of *DraI* in M buffer (Takara Bio Inc.) or *MspI* in L buffer (Takara Bio Inc.) at 37°C for 2 hr, respectively. The digests were separated by electrophoresis on 1% Seakem[®] GTG[®] agarose gel (Lonza, Basel, Switzerland), transferred to nylon membrane (GeneScreen Plus[®]: ParkinElmer Life Sciences, Inc., Boston, MA, U.S.A.) as described by Southern [28] and hybridized with ³²P-labeled *CucdtB* gene-probe under stringent condition. Radioactivity was visualized by FLA-7000 biomolecular imager (GE Healthcare Ltd.).

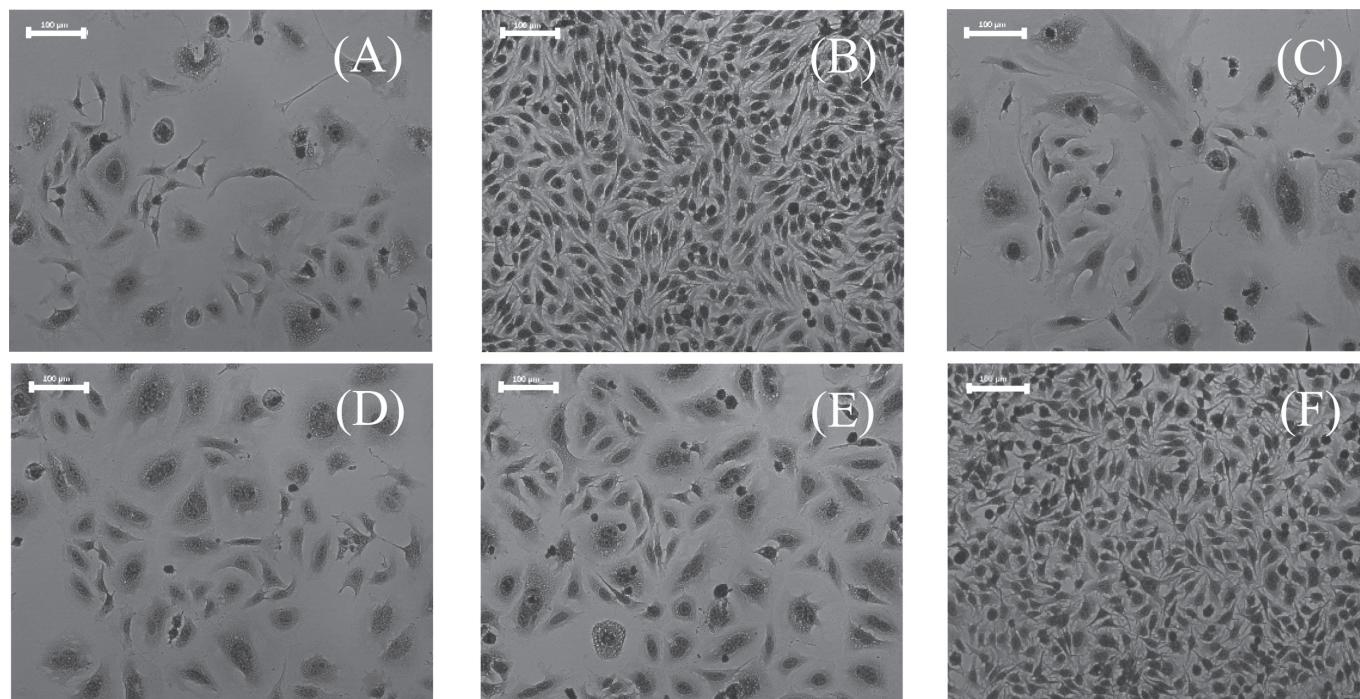

Fig. 1. Neutralization of cytotoxicity caused by bacterial sonic cell lysate of *C. upsaliensis*. HeLa cells were cultured with filter sterilized bacterial sonic cell lysate of *C. upsaliensis* strain ATCC 43954 (A) filter sterilized bacterial sonic cell lysate of *C. upsaliensis* strain ATCC 43954 with either anti-rCuCdtC (B) or pre-immunization serum (C), filter sterilized bacterial sonic cell lysate of rChCDT-II (CDT positive) (D) filter sterilized bacterial sonic cell lysate of rChCDT-II with anti-rCuCdtC serum (E) and filter sterilized bacterial sonic cell lysate of *C. jejuni* strain K328 (CDT negative) (F). After 72 hr incubation, cells were stained and observed by microscopy (magnification $\times 200$). Scale bars correspond to 100 μm in all images.

Western blotting

Western blotting was performed as described previously [17] with minor modification. Briefly, bacterial sonic cell lysate of *C. upsaliensis* strains, ATCC 43954, 40-1 and 99-1, and *C. hyointestinalis* strain ATCC 35217, purified rCuCdtC and rChCdt-IIC were analyzed by SDS-PAGE using 15% gel and blotted to polyvinylidene difluoride (PVDF) membrane by using semi-dry transfer cell (TRANS BLOT SD, Bio-Rad Laboratories Inc.). Then, the membrane was reacted with 1,000 times diluted rabbit anti-rCuCdtC serum and further incubated with 30,000 times diluted horseradish peroxidase (HRP)-conjugated donkey anti-rabbit IgG antibody (GE Healthcare Ltd.). Reactive protein was detected by using ECL Prime Western Blotting Detection Reagent (GE Healthcare Ltd.).

Nucleotide sequence accession numbers

Entire *cdt* gene sequences of *C. upsaliensis* analyzed in this study have been registered in the DNA Data Bank of Japan (DDBJ), and their details (strain/accession no.) are as follows. ATCC 43954/LC201621, 40-1/LC201622 and 99-1/LC201623.

RESULTS

Nucleotide sequences of the *Cucdt* genes

A *cdtB* gene-based PCR-RFLP assay established by Kamei *et al.* yielded 3 different RFLP patterns from *C. upsaliensis* [16]. A representative strain of each RFLP pattern was selected, and nucleotide sequence of entire *Cucdt* genes of strains ATCC 43954 (Cu-I), 40-1 (Cu-II) and 99-1 (Cu-III) was determined. Nucleotide sequence analysis revealed that each strain harbored *Cucdt* gene cluster with 2,106 bp in size, comprised of 3 adjacent genes, *cdtA* (735 bp), *cdtB* (801 bp) and *cdtC* (570 bp). Homology between prototype and newly determined *Cucdt* genes was 94 to 98% with *cdtA*, 93 to 94% with *cdtB* and 92 to 93% with *cdtC*, while that between amino acids of CuCDT was 95 to 99% with CdtA, 97 to 98% with CdtB and 92 to 93% with CdtC. The putative amino acid residues (H152, G184-N187, D222, D256 and H257) in CdtB important for DNase I activity were conserved in all strains analyzed in this study [30].

Cytotoxic effects of CuCDT on HeLa cells

As *C. upsaliensis* harbors the entire *cdt* genes, cytotoxic effects were examined in HeLa cells with filter sterilized bacterial sonic cell lysate of representative strains of each RFLP pattern. Filter sterilized bacterial sonic cell lysate of *C. upsaliensis* strain ATCC 43954 (Cu-I) caused cell distention (Fig. 1A), G₂/M cell cycle arrest (data not shown) and γ H2AX (Fig. 2A–2C) in response to

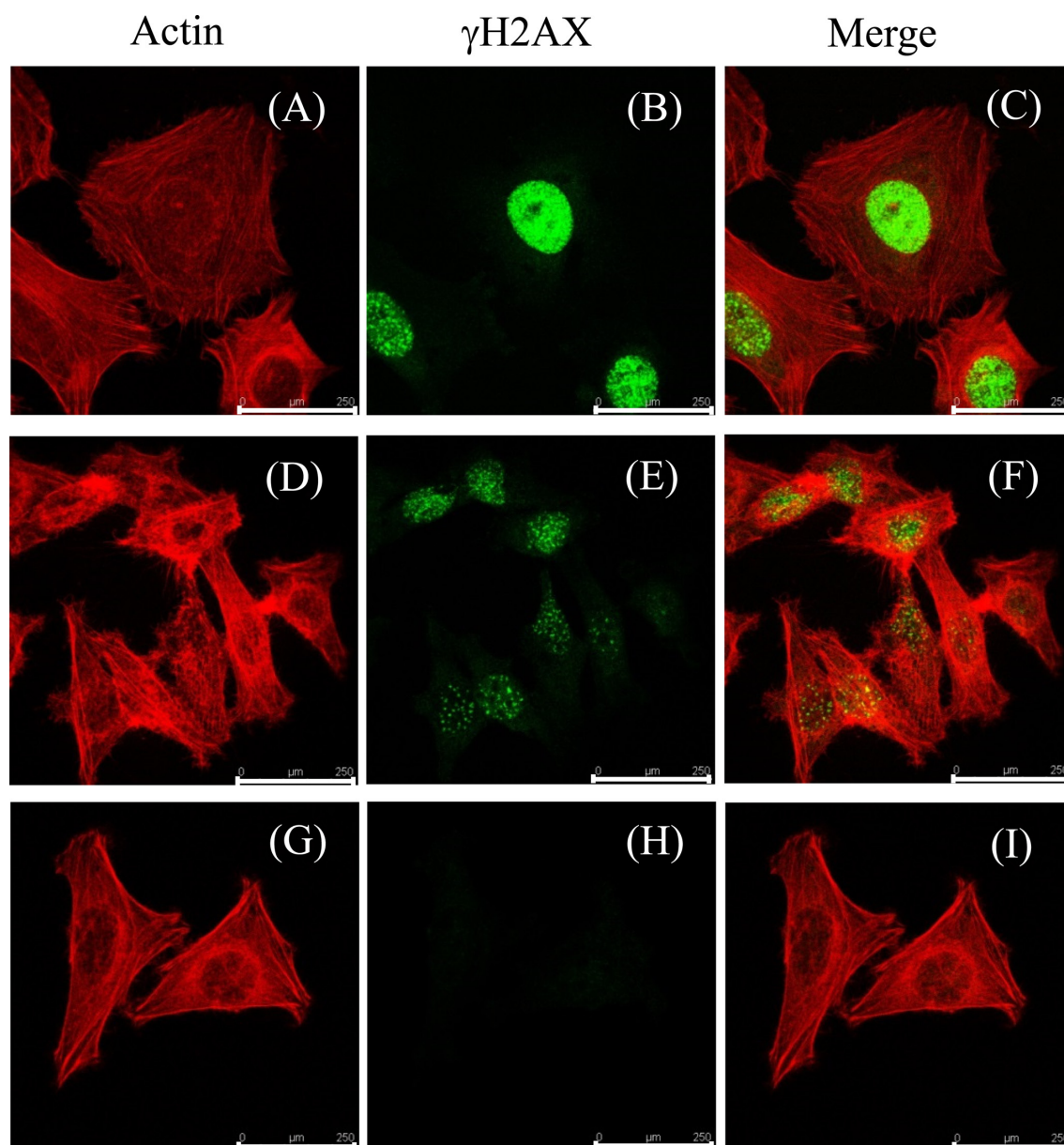

Fig. 2. Phosphorylation of histone H2AX (γ H2AX) in response to DNA damage caused by *C. upsaliensis* CDT. HeLa cells were cultured with filter sterilized bacterial sonic cell lysates of *C. upsaliensis* strain ATCC 43954 (A, B and C), rChCDT-II (CDT positive) (D, E and F) and *C. jejuni* strain K328 (CDT negative) (G, H and I). After 24 hr incubation, actins were stained with Alexa Fluor 546-conjugated phalloidin (orange color), and γ H2AX was stained with fluorescein isothiocyanate-conjugated anti-phospho-histone H2AX monoclonal antibody (green color). The cells were then observed by fluorescence microscopy (magnification $\times 630$). Scale bars correspond to 250 μ m in all images.

DNA damage in intoxicated cells. In accordance with the result of strain ATCC 43954, filter sterilized bacterial sonic cell lysate of *C. upsaliensis* strains 40-1 (Cu-II) and 99-1 (Cu-III) also showed CDT activity in intoxicated cells (data not shown). Furthermore, CDT activity was completely neutralized in the presence of antiserum against rCuCdtC (Fig. 1B), but not by pre-immunization serum (Fig. 1C). In contrast, the antiserum could not neutralize the cytotoxicity produced by rChCDT-II (Fig. 1E). In addition, G₂/M cell cycle arrest induced by filter sterilized bacterial sonic cell lysate of *C. upsaliensis* strain ATCC 43954 (Cu-I) was also completely neutralized by anti-rCuCdtC serum (data not shown). Similarly, CDT activity of *C. upsaliensis* strains 40-1 (Cu-II) and 99-1 (Cu-III) was also completely neutralized by antiserum against rCuCdtC (data not shown).

Southern hybridization assay

To examine whether high CDT titer of *C. upsaliensis* strains is due to the copy number of *Cucdt* genes, Southern hybridization assay was carried out by using ³²P-labeled *CucdtB* gene-probe. When genomic DNA was digested with *Dra*I, whose restriction site is not present in the *CucdtB* gene-probe region, only one reactive band was detected in all 3 strains. When digested with *Msp*I,

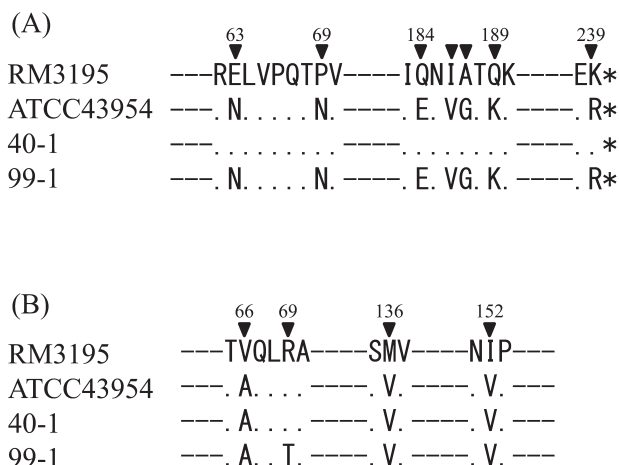

Fig. 3. Alignment of amino acids of CdtA (A) and CdtC (B) which might affect biological activity of CuCDTs. Amino acid sequences are aligned by the using the ClustalW program. Dot indicates the identical amino acid residue to that of prototype CuCDT in *C. upsaliensis* strain RM3195.

whose restriction site is there in *CucdtB* gene-probe region, 2 reactive bands were obtained from all 3 strains. On the other hand, no reactive signals were obtained from *E. coli* strain C600 and *C. hyointestinalis* strain ATCC 35217 used as a negative control (data not shown).

Quantitative analysis of CDT activity on HeLa cells

We further examined CDT activity quantitatively in comparison to that produced by other campylobacters. As shown in Table 1, CDT activity of *C. upsaliensis* on HeLa cells was much higher than that of other campylobacters, such as *C. jejuni*, *C. fetus*, *C. hyointestinalis* and *C. lari*. Interestingly, *C. upsaliensis* strain 99-1 (Cu-III) showed highest toxin titer, which was 65,536 times, and *C. upsaliensis* strain 40-1 (Cu-II) showed lowest toxin titer, which was 1,024 times. When we analyzed expression level of CuCdtC by western blotting using anti-rCuCdtC serum, there was no significant difference between these two strains (data not shown). These data indicate that CDT produced by *C. upsaliensis* strain 99-1 (Cu-III) is more toxic to HeLa cells than that of *C. upsaliensis* strain 40-1 (Cu-II).

DISCUSSION

We have previously developed a *cdtB* gene-based PCR-RFLP assay to detect and identify 7 CDT-producing *Campylobacter* species including *C. upsaliensis*. Then, 22 *C. upsaliensis* strains were typed into 3 groups (Cu-I to Cu-III) on the basis of the RFLP patterns [16]. In this study, entire *cdt* genes of 3 *C. upsaliensis* strains selected from each group were sequenced. It was found that *cdt* genes obtained were highly homologous to those of prototype reported by Fouts *et al.* [5], and there were subtle differences among *cdt* genes of each representative strain of *C. upsaliensis* (Cu-I to Cu-III) at nucleotide and amino acids levels. Interestingly, CDT activity produced by *C. upsaliensis* was much higher than that produced by other campylobacters (Table 1), although copy number of *Cucdt* genes was determined to be one in all 3 strains by Southern hybridization assay using ³²P-labeled *CucdtB* gene-probe (data not shown). Moreover, CDT activity produced by *C. upsaliensis* strains 99-1 (Cu-III) and 40-1 (Cu-II) showed highest (65,536) and lowest titer (1,024), respectively, while that produced by *C. upsaliensis* strain ATCC 43954 (Cu-I) showed titer 8,192 times. This indicates that CDT of Cu-III is 64 times higher and that of Cu-I is 8 times higher than that of Cu-II. However, production level of each CDT determined by western blotting was nearly identical among these 3 strains. When amino acid sequences of each CDT were compared, it was found that arginine at position 69 in CdtC is conserved in strains ATCC 43954 (Cu-I) and 40-1 (Cu-II), but it has been replaced with threonine of CdtC in strain 99-1 (Cu-III). Furthermore, 7 amino acid residues in CdtA of strains ATCC 43954 (Cu-I) and 99-1 (Cu-III) were conserved, but differed from those in CdtA of strain 40-1 (Cu-II) (Fig. 3). These amino acids substitution might be involved in decrease and increase of CDT activity.

To confirm this possibility, we attempted to clone the entire *cdt* genes from *C. upsaliensis* strains 99-1 (Cu-III) and 40-1 (Cu-II) by site-directed mutagenesis, however, it was unsuccessful. Then, we also attempted to clone each subunit gene, express each subunit protein and reconstitute holotoxin with rCuCdtA, rCuCdtB and rCuCdtC as described previously [27]. *CucdtB* and *CucdtC* genes were successfully cloned, their gene products were expressed in *E. coli*, and rCuCdtB and rCuCdtC were successfully purified. However, it was unsuccessful to clone *CucdtA* gene. Thus, holotoxin was unable to be reconstituted. At this moment, there is no way to confirm which amino acids contribute to increasing the CDT activity of *C. upsaliensis*. Further studies are certainly required to see which amino acid substitution is involved in differentiating the CDT activity or to understand why CuCDT produced by strain 99-1 (Cu-III) showed higher titer in comparison to other CuCDTs produced by strains ATCC 43954 (Cu-I) and 40-1 (Cu-II).

C. upsaliensis is often isolated from healthy dogs and cats. However, virulence mechanisms of *C. upsaliensis* remain unclear. It has been reported that *C. jejuni*, *C. fetus*, *C. hyointestinalis*, *C. lari*, and *C. upsaliensis* produce a biologically active CDT [17, 18, 20, 23–24, 27]. CDT is one of the possible virulence factors in campylobacters. For example, Fox *et al.* showed that CDT might be responsible for persistent gut colonization of *C. jejuni* in a mouse model [6]. Furthermore, Jain *et al.* reported that CDT produced by *C. jejuni* could cause inflammation with mucosal denudation and necrosis affecting the jejunum, ileum and colon in mice [13]. Since *C. jejuni* is being most frequently isolated *Campylobacter* species from patients, it represents the principal human pathogen of the genus [14], and accordingly, CDT might be contribute to the virulence of *Campylobacter*. *C. upsaliensis* was isolated from patient with not only diarrhea but also sepsis. But, this organism does not seem to be harmful to dogs and cats. *C. upsaliensis* producing high CDT titer seems to be more virulent to human. In this study, we only analyzed *C. upsaliensis* originated from dogs and CDT production *in vitro*. Further studies regarding sequencing of *cdt* genes and analysis of CDT activity of different human isolates of *C. upsaliensis* will be required to confirm the findings of this study.

In conclusion, we demonstrated that *cdt* genes of *C. upsaliensis* are variable, cytotoxicity caused by *C. upsaliensis* is due to CuCDT, and CDT activity produced by *C. upsaliensis* is much higher than that produced by other campylobacters. CDT activity produced by *C. upsaliensis* is variable, and high toxin titer seems to be due to amino acid substitutions in CdtA and CdtC of *C. upsaliensis*, which may affect the nature of protein conformation, but not production level. High toxin titer produced by *C. upsaliensis* may be associated with cause of human diseases, such as gastroenteritis and sepsis.

ACKNOWLEDGMENTS. We thank Dr. Rupak K. Bhadra (CSIR-Indian Institute of Chemical Biology, Kolkata, India) for the critical reading of the manuscript. *C. upsaliensis* strains (40-1, 48-1, 99-1 and 102-1) and *C. lari* strains (JCM 2530, 84c-1 and 264) were kindly provided by Prof. N. Misawa, Faculty of Agriculture, University of Miyazaki, Japan and Prof. M. Matsuda, School of Environmental Health Sciences, Azabu University, Japan, respectively. This study was performed in partial fulfillment of the requirements of a Ph.D. thesis for S. Somroop from the Graduate School of Life and Environmental Sciences, Osaka Prefecture University, Osaka, Japan. S. Somroop is recipient of scholarship from the Thai Royal Government.

REFERENCES

1. Alam, K., Lastovica, J. A., Roux, E., Anowar Hossain, M., Nazrul Islam, M., Sen, S. K., Sur, G. C., Balakrish Nair, G. and Sack, D. A. 2006. Clinical characteristics and serotype distribution of *Campylobacter jejuni* and *Campylobacter coli* isolated from diarrhoeic patients in Dhaka, Bangladesh, and Cape Town, South Africa. *Bangladesh J. Microbiol.* **23**: 121–124.
2. Asakura, M., Samosornsuk, W., Taguchi, M., Kobayashi, K., Misawa, N., Kusumoto, M., Nishimura, K., Matsuhiya, A. and Yamasaki, S. 2007. Comparative analysis of cytolethal distending toxin (*cdt*) genes among *Campylobacter jejuni*, *C. coli* and *C. fetus* strains. *Microb. Pathog.* **42**: 174–183. [Medline] [CrossRef]
3. Bojanić, K., Midwinter, A. C., Marshall, J. C., Rogers, L. E., Biggs, P. J. and Acke, E. 2016. Isolation of *Campylobacter* spp. from client-owned dogs and cats, and retail raw meat pet food in the Manawatu, New Zealand. *Zoonoses Public Health* **10.1111/zph.12323**. [Medline]
4. Carter, J. E. and Cimolai, N. 1996. Hemolytic-uremic syndrome associated with acute *Campylobacter upsaliensis* gastroenteritis. *Nephron* **74**: 489. [Medline] [CrossRef]
5. Fouts, D. E., Mongodin, E. F., Mandrell, R. E., Miller, W. G., Rasko, D. A., Ravel, J., Brinkac, L. M., DeBoy, R. T., Parker, C. T., Daugherty, S. C., Dodson, R. J., Durkin, A. S., Madupu, R., Sullivan, S. A., Shetty, J. U., Ayodeji, M. A., Shvartsbeyn, A., Schatz, M. C., Badger, J. H., Fraser, C. M. and Nelson, K. E. 2005. Major structural differences and novel potential virulence mechanisms from the genomes of multiple *Campylobacter* species. *PLoS Biol.* **3**: e15. [Medline] [CrossRef]
6. Fox, J. G., Rogers, A. B., Whary, M. T., Ge, Z., Taylor, N. S., Xu, S., Horwitz, B. H. and Erdman, S. E. 2004. Gastroenteritis in NF-kappaB-deficient mice is produced with wild-type *Campylobacter jejuni* but not with *C. jejuni* lacking cytolethal distending toxin despite persistent colonization with both strains. *Infect. Immun.* **72**: 1116–1125. [Medline] [CrossRef]
7. Giacomelli, M., Follador, N., Coppola, L. M., Martini, M. and Piccirillo, A. 2015. Survey of *Campylobacter* spp. in owned and unowned dogs and cats in Northern Italy. *Vet. J.* **204**: 333–337. [Medline] [CrossRef]
8. Goddard, E. A., Lastovica, A. J. and Argent, A. C. 1997. *Campylobacter* 0:41 isolation in Guillain-Barré syndrome. *Arch. Dis. Child.* **76**: 526–528. [Medline] [CrossRef]
9. Goossens, H., Giesendorf, B. A. J., Vandamme, P., Vlaes, L., Van den Borre, C., Koeken, A., Quint, W. G. V., Blomme, W., Hanicq, P., Koster, D. S., Hofstra, H., Butzler, J. P. and Van der Plas, J. 1995. Investigation of an outbreak of *Campylobacter upsaliensis* in day care centers in Brussels: analysis of relationships among isolates by phenotypic and genotypic typing methods. *J. Infect. Dis.* **172**: 1298–1305. [Medline] [CrossRef]
10. Goossens, H., Vlaes, L., Butzler, J. P., Adnet, A., Hanicq, P., N'Jufom, S., Massart, D., de Schrijver, G. and Blomme, W. 1991. *Campylobacter upsaliensis* enteritis associated with canine infections. *Lancet* **337**: 1486–1487. [Medline] [CrossRef]
11. Gurgan, T. and Diker, K. S. 1994. Abortion associated with *Campylobacter upsaliensis*. *J. Clin. Microbiol.* **32**: 3093–3094. [Medline]
12. Ho, T. W., Hsieh, S. T., Nachamkin, I., Willison, H. J., Sheikh, K., Kiehlbauch, J., Flanigan, K., McArthur, J. C., Cornblath, D. R., McKhann, G. M. and Griffin, J. W. 1997. Motor nerve terminal degeneration provides a potential mechanism for rapid recovery in acute motor axonal neuropathy after *Campylobacter* infection. *Neurology* **48**: 717–724. [Medline] [CrossRef]
13. Jain, D., Prasad, K. N., Sinha, S. and Husain, N. 2008. Differences in virulence attributes between cytolethal distending toxin positive and negative *Campylobacter jejuni* strains. *J. Med. Microbiol.* **57**: 267–272. [Medline] [CrossRef]
14. Kaakoush, N. O., Castaño-Rodríguez, N., Mitchell, H. M. and Man, S. M. 2015. Global Epidemiology of *Campylobacter* Infection. *Clin. Microbiol. Rev.* **28**: 687–720. [Medline] [CrossRef]
15. Kabir, S. M., Kikuchi, K., Asakura, M., Shiramaru, S., Tsuruoka, N., Goto, A., Hinenoya, A. and Yamasaki, S. 2011. Evaluation of a cytolethal distending toxin (*cdt*) gene-based species-specific multiplex PCR assay for the identification of *Campylobacter* strains isolated from diarrheal patients in Japan. *Jpn. J. Infect. Dis.* **64**: 19–27. [Medline]
16. Kamei, K., Asakura, M., Somroop, S., Hatanaka, N., Hinenoya, A., Nagita, A., Misawa, N., Matsuda, M., Nakagawa, S. and Yamasaki, S. 2014. A PCR-RFLP assay for the detection and differentiation of *Campylobacter jejuni*, *C. coli*, *C. fetus*, *C. hyointestinalis*, *C. lari*, *C. helveticus* and *C.*

- upsaliensis*. *J. Med. Microbiol.* **63**: 659–666. [Medline] [CrossRef]
17. Kamei, K., Hatanaka, N., Asakura, M., Somroop, S., Samosornsuk, W., Hinenoya, A., Misawa, N., Nakagawa, S. and Yamasaki, S. 2015. *Campylobacter hyointestinalis* isolated from pigs produces multiple variants of biologically active cytolethal distending toxin. *Infect. Immun.* **83**: 4304–4313. [Medline] [CrossRef]
 18. Lastovica, A. 2006. Emerging *Campylobacter* spp.: The tip of the iceberg. *Clin. Microbiol. Newsl.* **28**: 49–56. [CrossRef]
 19. Lee, R. B., Hassane, D. C., Cottle, D. L. and Pickett, C. L. 2003. Interactions of *Campylobacter jejuni* cytolethal distending toxin subunits CdtA and CdtC with HeLa cells. *Infect. Immun.* **71**: 4883–4890. [Medline] [CrossRef]
 20. Matsuda, M., Shigematsu, M., Tazumi, A., Sekizuka, T., Takamiya, S., Millar, B. C., Taneike, I. and Moore, J. E. 2008. Cloning and structural analysis of the full-length cytolethal distending toxin (*cdt*) gene operon from *Campylobacter lari*. *Br. J. Biomed. Sci.* **65**: 195–199. [Medline] [CrossRef]
 21. Mooney, A., Clyne, M., Curran, T., Doherty, D., Kilmartin, B. and Bourke, B. 2001. *Campylobacter upsaliensis* exerts a cytolethal distending toxin effect on HeLa cells and T lymphocytes. *Microbiology* **147**: 735–743. [Medline] [CrossRef]
 22. Nakamura, I., Omori, N., Umeda, A., Ohkusu, K. and Matsumoto, T. 2015. First case report of fatal sepsis due to *Campylobacter upsaliensis*. *J. Clin. Microbiol.* **53**: 713–715. [Medline] [CrossRef]
 23. Ohya, T., Tominaga, K. and Nakazawa, M. 1993. Production of cytolethal distending toxin (CLDT) by *Campylobacter fetus* subsp. *fetus* isolated from calves. *J. Vet. Med. Sci.* **55**: 507–509. [Medline] [CrossRef]
 24. Pickett, C. L., Pesci, E. C., Cottle, D. L., Russell, G., Erdem, A. N. and Zeytin, H. 1996. Prevalence of cytolethal distending toxin production in *Campylobacter jejuni* and relatedness of *Campylobacter* sp. *cdtB* gene. *Infect. Immun.* **64**: 2070–2078. [Medline]
 25. Purdy, D., Buswell, C. M., Hodgson, A. E., McAlpine, K., Henderson, I. and Leach, S. A. 2000. Characterisation of cytolethal distending toxin (CDT) mutants of *Campylobacter jejuni*. *J. Med. Microbiol.* **49**: 473–479. [Medline] [CrossRef]
 26. Rossi, M., Hänninen, M. L., Revez, J., Hannula, M. and Zaroni, R. G. 2008. Occurrence and species level diagnostics of *Campylobacter* spp., enteric *Helicobacter* spp. and *Anaerobiospirillum* spp. in healthy and diarrheic dogs and cats. *Vet. Microbiol.* **129**: 304–314. [Medline] [CrossRef]
 27. Samosornsuk, W., Kamei, K., Hatanaka, N., Taguchi, T., Asakura, M., Somroop, S., Sugimoto, N., Chaicumpa, W. and Yamasaki, S. 2015. A new variant of cytolethal distending toxin in a clinical isolate of *Campylobacter hyointestinalis*. *J. Med. Microbiol.* **64**: 1124–1134. [Medline] [CrossRef]
 28. Southern, E. M. 1975. Detection of specific sequences among DNA fragments separated by gel electrophoresis. *J. Mol. Biol.* **98**: 503–517. [Medline] [CrossRef]
 29. Vandenberg, O., Houf, K., Douat, N., Vlaes, L., Retore, P., Butzler, J. P. and Dediste, A. 2006. Antimicrobial susceptibility of clinical isolates of non-*jejuni/coli* campylobacters and arcobacters from Belgium. *J. Antimicrob. Chemother.* **57**: 908–913. [Medline] [CrossRef]
 30. Yamasaki, S., Asakura, M., Tsukamoto, T., Faruque, S. M., Reema, D. and Ramamurthy, T. 2006. Cytolethal distending toxin (CDT): genetic diversity, structure and role in diarrheal disease. *Toxin Rev.* **25**: 61–88. [CrossRef]
 31. Yutsudo, T., Nakabayashi, N., Hirayama, T. and Takeda, Y. 1987. Purification and some properties of a Vero toxin from *Escherichia coli* O157:H7 that is immunologically unrelated to Shiga toxin. *Microb. Pathog.* **3**: 21–30. [Medline] [CrossRef]