

Minireview

## Imprinting: silently crossing the boundary

Jo Peters

Address: Mammalian Genetics Unit, Medical Research Council, Harwell, Didcot, Oxfordshire OX11 0RD, UK.  
E-mail: J.Peters@har.mrc.ac.uk

Published: 10 November 2000

Genome **Biology** 2000, **1**(5):reviews1028.1–1028.4

The electronic version of this article is the complete one and can be found online at <http://genomebiology.com/2000/1/5/reviews/1028>

© Genome**Biology**.com (Print ISSN 1465-6906; Online ISSN 1465-6914)

### Abstract

Recent studies have identified silencers as control elements that may interact with enhancers to regulate the expression of imprinted genes.

Imprinting is an epigenetic process that marks the parental origin of a subset of genes; it results in the silencing of one or other parental copy of each gene. One mark that distinguishes the two parental alleles of imprinted genes is differential methylation: one allele is more heavily methylated than the other. In addition, an array of controlling elements with diverse functions that interact to regulate imprinting are now being identified and these, too, may be differentially methylated. Recent findings have highlighted the role of one type of controlling element, the silencer, in regulating the expression of imprinted genes, and indicate that these silencers may do this by interacting with enhancers [1-3].

The recent advances have come from work on two intensively studied imprinted genes in the mouse, *Igf2* and *H19*. *Igf2* encodes a potent fetal growth factor and *H19* encodes a non-protein-coding RNA. The two genes are closely linked, lying only 90 kilobases apart, and are reciprocally imprinted: on the paternal chromosome *H19* is not transcribed and *Igf2* is transcriptionally active, whereas the reciprocal situation occurs on the maternal chromosome. At issue is the mechanism underlying this phenomenon - and differential methylation of control elements provides the key.

### The differentially methylated domain

Several kilobases upstream of *H19* is an element called the differentially methylated domain (DMD), which has multiple functions and is essential for the imprinting of both *H19* and *Igf2* [4]. The DMD is methylated on the paternal

chromosome, where it is needed for switching off *H19*, but it is unmethylated on the maternal chromosome, where it is needed for switching off *Igf2* (Figure 1).

Transfection of the 3' region of the mouse DMD into *Drosophila* has shown that it can act as a silencer [5]. Now, work in the mouse [1,6] has shown that this 3' region (see Figure 1a) indeed silences *H19* on the methylated paternal chromosome. Thus, a targeted deletion of this silencer region on a chromosome inherited from the father allows *H19* to be active, whereas when the same chromosome is inherited from the mother, there is no detectable effect on *H19*. Surprisingly, the deletion did not affect the parent-of-origin-driven differential methylation of *H19* [1], suggesting that the sequences controlling differential methylation are upstream of the deletion.

Another role for the DMD has been found when it is maternally transmitted, and therefore unmethylated. Earlier this year, it was shown that in its unmethylated state the DMD acts as a boundary element - a *cis*-acting element that blocks the effects of distal enhancers (Figure 1b) [7-10]. The DMD lies between *Igf2* and enhancers downstream of *H19* (Figure 1). According to the current model, the unmethylated DMD blocks the interaction of enhancers with the maternal *Igf2* promoter to prevent *Igf2* expression from the maternal chromosome. By contrast, the methylated DMD does not appear to have enhancer-blocking activity, so the enhancers can access *Igf2* on the paternal chromosome, allowing expression of the gene to occur.

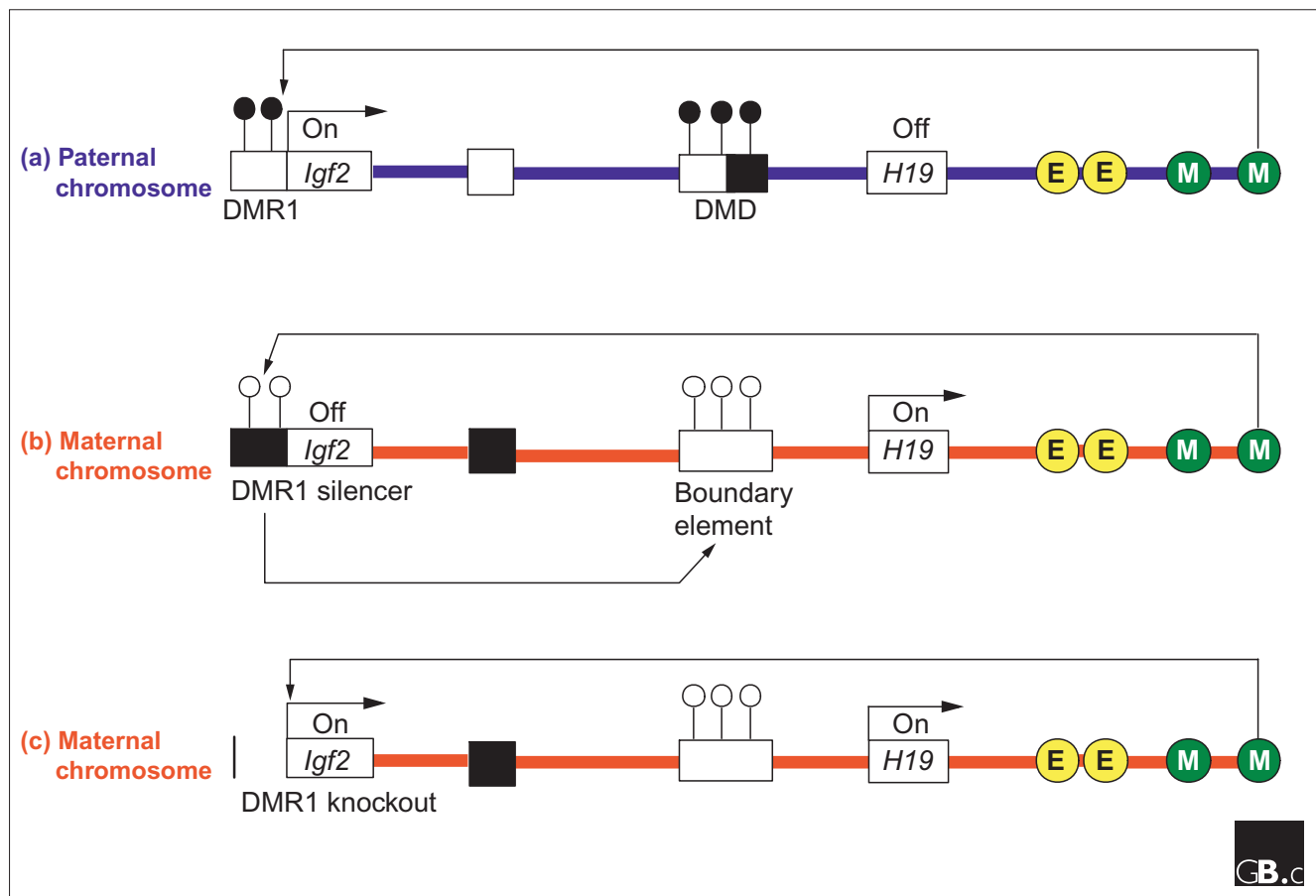
**Figure 1**

Silencers around *Igf2* and *H19*. The *Igf2* gene is expressed from the paternal and the *H19* gene from the maternal chromosome. Both genes share enhancers located downstream of *H19*, with the mesoderm (M) enhancers further downstream than the endoderm (E) enhancers. On the paternal chromosome (a), *Igf2* uses the enhancers and *H19* is switched off, whereas on the maternal chromosome (b), *H19* uses the enhancers and *Igf2* is switched off. (Transcription from *Igf2* and *H19* is shown by arrows.) Two differentially methylated regions are shown, the DMD, upstream of *H19*, and DMR1 at *Igf2*, both of which are methylated (shown by closed circles) on the paternal chromosome and unmethylated (open circles) on the maternal chromosome. The ability of the endoderm enhancers to affect transcription of *H19* and *Igf2* is controlled by the DMD, upstream of *H19*: when the DMD is methylated (on the paternal chromosome), the enhancers activate the *Igf2* promoters. When unmethylated (on the maternal chromosome) the DMD acts as a boundary element, preventing the enhancers from accessing the *Igf2* promoters. Recent work [1-3] has shown that three regions act as tissue-specific silencers (active silencers are shown by black boxes) of either *H19* or *Igf2*. One, at the DMD, silences *H19* on the paternal chromosome, and two silence *Igf2* on the maternal chromosome. One located midway between *Igf2* and *H19* silences *Igf2* in muscle, and DMR1 silences *Igf2* in other mesodermal tissues. When DMR1 is knocked out (c), the silencer activity is lost and *Igf2* is expressed from the maternal chromosome as well as the paternal chromosome: it is no longer imprinted. It is postulated that normally either the mesodermal enhancers are able to circumvent the boundary but are prevented from activating the promoter by the silencer, or that the silencer and boundary elements interact, and stop the mesodermal enhancers from accessing the promoter. When the silencer is deleted, *Igf2* can be expressed. Putative interactions between a mesoderm enhancer and promoters or silencers at DMR1 are shown by lines and arrows.

### Silencers

The identification of this DMD boundary element appears to provide a satisfactory explanation for the repression of maternal *Igf2*, but it is clearly not the whole story. New work [2,3] has shown that two further elements can prevent *Igf2* expression, and both are silencers. These elements act specifically on *Igf2* in mesodermal tissues, independent of any effect on *H19*. Interestingly, the results of the new work indicate that in the mesoderm the boundary does not form a

complete block between enhancer and promoter; it can be crossed in some circumstances.

One of the newly identified elements is another differentially methylated region, DMR1, which is about 1.5 kilobases in size and lies at the 5' end of *Igf2*. This region is hypermethylated on the paternal chromosome but is unmethylated on the maternal chromosome. It had been hypothesized that when it is unmethylated DMR1 has a silencer function, thus

preventing transcription of maternal *Igf2* [11-14]; when methylated, the silencer is envisaged to be no longer functional, allowing transcription of paternal *Igf2*. Confirmation of this idea has come from Constância and colleagues [3], in functional studies with a mouse lacking DMR1; the 'knock-out' region also encompasses a block of direct repeats just upstream of DMR1. When the knockout is maternally inherited (Figure 1c), *Igf2* is no longer silent: it is transcribed from the maternal chromosome - there is loss of imprinting resulting in biallelic expression. On paternal transmission, transcription in the embryo was unaffected. An additional finding was that the DMR1 silencer appeared to be specific for *Igf2* within mesodermal tissues only, with the exception of muscle; it did not silence *Igf2* in endoderm.

The other new *Igf2* silencer is specific for muscle [2]. This silencer is a 1 kilobase element located midway between *Igf2* and *H19* that contains nuclease-hypersensitive sites characteristic of control regions and shows homology with the corresponding human sequence but is not differentially methylated [15], so the nature of the epigenetic mark is unclear. Deletion of this element resulted in reactivation of *Igf2* in muscle on maternal transmission, particularly in the tongue [2]. This is of interest in relation to the loss of imprinting of *IGF2* that occurs in the human genetic disorder Beckwith Wiedemann syndrome (BWS), which is associated with fetal overgrowth and predisposition to childhood tumors. Enlargement of the tongue is the most consistent feature of BWS, a feature that might correspond to the strong reactivation of *Igf2*, a potent growth factor, in the mouse tongue following deletion of the muscle-specific silencer.

### Boundary effects

The model discussed here (Figure 1) for switching off maternally derived *Igf2* predicts that the boundary element located between the promoter and enhancers prevents the downstream enhancers from accessing the *Igf2* promoters, thus stopping *Igf2* transcription. The model is based on the well-known endoderm enhancers but is expected to apply to mesodermal tissues as well, because the mesodermal enhancers, like the endoderm enhancers, are distal to the boundary element (see Figure 1) [3,16,17]. According to the boundary model, maternal *Igf2* should be switched off in the DMR1 knockout - but contrary to expectation, it is in fact switched on. So how is maternal *Igf2* derepressed in the mesoderm of the knockout? Constância *et al.* [3] proposed two alternative mechanisms. One is that normally the mesoderm enhancers interact with the unmethylated DMR1 silencer on the maternal chromosome (Figure 1b), so that transcription of *Igf2* is prevented. To achieve this, the boundary element would have to be circumvented, at least partially. When DMR1 is knocked out, it is postulated that the mesoderm enhancers activate the *Igf2* promoters; there is no DMR1 silencing activity (Figure 1c). The second mechanism proposed by Constância *et al.* [3] is that DMR1

normally interacts with the boundary element to prevent the downstream enhancers from accessing the promoter (Figure 1b). This proposal implies that in mesoderm the boundary element needs to interact with the silencer to be fully functional; in the DMR1 knockout the interaction is lost, and leads to lifting of the boundary (Figure 1c). Interactions between the muscle enhancer and silencer can also be proposed. Whatever the mechanism, the experiments show that control of expression of imprinted genes can involve interaction between enhancers and epigenetically regulated silencers.

### Phenotypes

The phenotypic effects that result from deletion of DMR1 are intriguing. An unexpected result was that there was no increase in growth in mice carrying the maternally derived DMR1 knockout, despite the loss of imprinting of *Igf2*. This is surprising, because in other knockouts where biallelic expression of *Igf2* occurred, an increase in size was found; but in these mutants *H19* expression was also disrupted [4,18,19]. Future studies of the levels of Igf2 peptide in the mesoderm of DMR1 knockout mice may provide an explanation of these apparently disparate findings. A second phenotypic observation is also worthy of note. On paternal transmission, the DMR1 knockout mice underwent intrauterine growth retardation, so they were small at birth. This was expected because of the design of the knockout construct: a paternal placenta-specific transcript is absent. But both maternal and paternal transmission of the knockout allele led to extended postnatal expression of *Igf2* (suggesting that a non-imprinted element controlling the duration of expression lies in the sequence covered by the knockout). The extended postnatal expression of Igf2 enabled the mice that had a paternally derived DMR1 knockout allele and were small at birth to catch up in size with their normal sibs by the time of weaning. The situation in mice may be pertinent to that in humans, where loss of imprinting of *IGF2* can occur without altering the imprinting of *H19* in hepatoblastoma and in many patients with BWS [20-22]. The recent findings now show that loss of imprinting of *Igf2* independent of *H19* occurs in mice as well. The *Igf2* silencers identified in mice add to the ever-increasing number of elements controlling the imprinting of *Igf2*; they provide additional targets for mutations that can lead to disruption of imprinting, and to diseases including cancer.

### Towards a mechanism

Imprinted genes tend to be clustered. *Igf2* and *H19* are at one end of a much larger cluster of at least 12 genes, covering 1 megabase on mouse distal chromosome 7 and the Beckwith-Wiedemann region on human chromosome 11p15.5. Could there be coordinate control of imprinting within the cluster, alongside control at a local level? There is not a clear answer as yet. Genes at either end of the cluster are

imprinted in both species, but those in the central region are not, implying that there is not coordinate control. X-chromosome inactivation provides a precedent for a central mechanism for inactivation, but it is known that some genes can escape X inactivation. Comparative genomic sequence analysis may provide some mechanistic answers, and the first such analysis has recently been carried out: 250 kilobases of the central part of the cluster from the mouse has been compared with the orthologous Beckwith-Wiedemann region in humans [23]. Of six orthologous genes identified which showed extensive structural and functional conservation, three were similarly imprinted in both species. Two of the three remaining gene pairs showed differences in imprinting: *Tssc4* is imprinted in mice but not in humans, and *LTRPC5* is imprinted in humans but not in mice. A third gene pair *Tssc6/TSSC6* is not imprinted in either species. Thus, cross-species conservation of domains will not provide us with a simple means of identifying domains important for imprinting. Nevertheless, imprinted genes within the cluster all contained CpG islands, regions that can be differentially methylated, but the non-imprinted genes did not. CpG islands are much more frequent around imprinted genes than elsewhere in the genome; they may be an essential feature of imprinted domains and indicate the presence of controlling elements. With the recently identified silencers and boundary elements, it is increasingly evident that a wide variety of controlling elements have been drawn into the process of imprinting.

### Acknowledgements

I thank Bruce Cattanaach, Chris Williamson and Judith Skinner for stimulating discussion and helpful comments, and Colin Beechey for preparing the figure.

### References

- Drewell RA, Brenton JD, Ainscough JFX, Barton SC, Hilton KJ, Arney KL, Dandolo L, Surani MA: **Deletion of a silencer element disrupts *H19* imprinting independently of a DNA methylation epigenetic switch.** *Development* 2000, **127**:3419-3428.
- Ainscough JFX, John RM, Barton SC, Surani MA: **A skeletal muscle-specific mouse *Igf2* repressor lies 40 kb downstream of the gene.** *Development* 2000, **127**:3923-3930.
- Constância M, Dean W, Lopes S, Moore T, Kelsey G, Reik W: **Deletion of a silencer element in the *Igf2* gene results in loss of imprinting independent of *H19*.** *Nat Genet* 2000, **26**:203-206.
- Thorvaldsen JL, Duran KL, Bartolomei MS: **Deletion of the *H19* differentially methylated domain results in loss of imprinted expression of *H19* and *Igf2*.** *Genes Dev* 1998, **12**:3693-3702.
- Lyko F, Brenton JD, Surani MA, Paro R: **An imprinting element from the mouse *H19* locus functions as a silencer in *Drosophila*.** *Nat Genet* 1997, **16**:171-173.
- Brenton JD, Drewell R, Viville KJ, Hilton SC, Barton SC, Ainscough JF-X, Surani MA: **A silencer element identified in *Drosophila* is required for imprinting of *H19* reporter transgenes in mice.** *Proc Natl Acad Sci USA* 1999, **96**:9242-9247.
- Hark AT, Schoenherr CJ, Katz DJ, Ingram RS, Levorse JM, Tilghman SM: **CTCF mediates methylation-sensitive enhancer-blocking activity at the *H19/Igf2* locus.** *Nature* 2000, **405**:486-489.
- Bell AC, Felsenfeld G: **Methylation of a CTCF-dependent boundary controls imprinted expression of the *Igf2* gene.** *Nature* 2000, **405**:482-485.
- Kanduri C, Holmgren C, Pilartz M, Franklin G, Kanduri M, Liu L, Ginjala V, Ulleras E, Mattsson R, Ohlsson R: **The 5' flank of mouse *H19* in an unusual chromatin conformation unidirectionally blocks enhancer-promoter communication.** *Curr Biol* 2000, **10**:449-457.
- Szabó PE, Tang S-HE, Rentsendorj A, Pfeifer GP, Mann JR: **Maternal-specific footprints at putative CTCF sites in the *H19* imprinting control region give evidence for insulator function.** *Curr Biol* 2000, **10**:607-610.
- Sasaki HP, Jones A, Chaillet JR, Ferguson-Smith AC, Barton C, Reik W, Surani MA: **Parental imprinting: potentially active chromatin of the repressed maternal allele of the mouse insulin-like growth factor II (*Igf2r*) gene.** *Genes Dev* 1992, **6**:1843-1856.
- Brandeis M, Kafri T, Ariel M, Chaillet JR, McCarrey J, Razin A, Cedar H: **The ontogeny of allele-specific methylation associated with imprinted genes in the mouse.** *EMBO J* 1993, **12**:3669-3677.
- Feil R, Walter J, Allen ND, Reik W: **Developmental control of allelic methylation in the imprinted mouse *Igf2* and *H19* genes.** *Development* 1994, **120**:2933-2943.
- Moore T, Constância M, Zubair M, Bailleul B, Sasaki H, Reik W: **Multiple imprinted sense and antisense transcripts, differential methylation and tandem repeats in a putative imprinting control region upstream of mouse *Igf2*.** *Proc Natl Acad Sci USA* 1997, **94**:12509-12514.
- Koide T, Ainscough J, Wijgerde M, Surani MA: **Comparative analysis of *Igf2/H19* imprinted domain: identification of a highly conserved intergenic DNase I hypersensitive region.** *Genomics* 1994, **24**:1-8.
- Ishihara K, Hatano N, Furuumi H, Kato R, Iwaki T, Miura K, Jinno Y, Sasaki H: **Comparative genomic sequencing identifies novel tissue-specific enhancers and sequence elements for methylation-sensitive factors implicated in *Igf2/H19* imprinting.** *Genome Res* 2000, **10**:664-671.
- Kaffer CR, Srivastava M, Park K-Y, Ives E, Hsieh S, Batlle J, Grinberg A, Huang S-P, Pfeifer K: **A transcriptional insulator at the imprinted *H19/Igf2* locus.** *Genes Dev* 2000, **14**:1908-1919.
- Leighton PA, Ingram RS, Egenschwiler J, Efstratiadis A, Tilghman SM: **Disruption of imprinting caused by deletion of the *H19* gene region in mice.** *Nature* 1995, **375**:34-39.
- Ripoche M-A, Kress C, Poirier F, Dandolo L: **Deletion of the *H19* transcription unit reveals the existence of a putative imprinting control element.** *Genes Dev* 1997, **11**:1596-1604.
- Rainier S, Dobry CJ, Feinberg AP: **Loss of imprinting in hepatoblastoma.** *Cancer Res* 1995, **55**:1836-1838.
- Brown KW, Villar AJ, Bickmore W, Clayton-Smith J, Catchpoole, D, Maher ER, Reik W: **Imprinting mutation in the Beckwith-Wiedemann syndrome leads to biallelic *IGF2* expression through an *H19* independent pathway.** *Hum Mol Genet* 1996, **5**:2027-2032.
- Joyce JA, Lam, WK, Catchpoole DJ, Jenks P, Reik W, Maher ER, Schofield PN: **Imprinting of *IGF2* and *H19*: lack of reciprocity in sporadic Beckwith-Wiedemann syndrome.** *Hum Mol Genet* 1997, **6**:1543-1548.
- Paulsen M, El-Maarri O, Engemann S, Strödicke M, Franck O, Davies K, Reinhard R, Reik W, Walter J: **Sequence conservation and variability of imprinting in the Beckwith-Wiedemann syndrome gene cluster in human and mouse.** *Hum Mol Genet* 2000, **9**:1829-1841.