

Evaluating recurrent episodes of malaria incidence in Timika, Indonesia, through a Markovian multiple-state model



Novyan Lusiyana ^a, Atina Ahdika ^{b, *}

^a Department of Parasitology, Faculty of Medicine, Universitas Islam Indonesia, Jalan Kaliurang Km 14.5 Sleman, Yogyakarta, 55584, Indonesia

^b Department of Statistics, Faculty of Mathematics and Natural Science, Universitas Islam Indonesia, Jalan Kaliurang Km 14.5 Sleman, Yogyakarta, 55584, Indonesia

ARTICLE INFO

Article history:

Received 21 November 2021

Received in revised form 30 March 2022

Accepted 31 May 2022

Available online 6 June 2022

Handling editor: Dr Lou Yijun

Keywords:

ITNs

IRS

Malaria

Markovian multiple-state model

Recurrent episodes

ABSTRACT

Background: The high prevalence of malaria in endemic areas generally stems from recurrence events, characterized by the appearance of malaria symptoms at the time of examination; nearly every resident is at risk of experiencing such a recurrence. The verified presence of *Plasmodium* sp is referred to as the Confirmed state, while the condition without confirmed *P. falciparum* is called the Undetected Parasitaemia state. After malaria treatment, a person can be in Aparasitaemic state or return to an Undetected Parasitaemia or Confirmed state due to non-adherence in complying with malaria therapy. In this study, we evaluate the characteristics of malaria recurrence in Timika, Indonesia, using the Markovian multiple-state model. In addition, we also simulate the probability of malaria recurrence after the implementation of several control strategies, including prevention strategies using insecticide-treated nets (ITNs) and indoor residual spraying (IRS).

Objective: This study aims to identify the transition probabilities of malaria recurrence with and without control strategies.

Methods: We use data from the medical records of malaria patients from the Naena Muktipura sub-health center in Timika, Papua, Indonesia, from March 2020 to March 2021. The data were grouped into two age categories: those under or over 24 years. The incidence of malaria in this area was modeled using a Markovian multiple-state model, dividing the incidence data based on the character of the patient's condition (Undetected Parasitaemia, Confirmed, or Aparasitaemic states) in order to obtain the patient's transition probabilities in each state. Furthermore, we simulate the recurrence probability given specific control strategies.

Results: There were 964 visits to the sub-health center at Naena Muktipura in which symptoms of malaria were reported. Specifically, the number of the malaria incidences in the groups under and over age 24 were 456 and 508, respectively. The modeling results indicate that the probability of recurrence in the over-24 age group is generally higher than that in the under-24 age group. However, the probability of this recurrence decreases over time. Furthermore, providing a control strategy can reduce the probability of recurrence and increase the probability of recovery for these patients.

Conclusion: In endemic areas, adherence to treatment and preventive measures can accelerate the healing process and reduce the probability of malaria recurrence. With proper treatment management, the use of ITNs and the application of IRS, the incidence of malaria can be reduced and recovery can be accelerated.

* Corresponding author.

E-mail address: atina.a@uii.ac.id (A. Ahdika).

Peer review under responsibility of KeAi Communications Co., Ltd.

1. Introduction

Malaria is an infectious disease and one of the leading health challenges globally. This disease is reportedly endemic in 87 countries around the world, including Indonesia (WHO, 2020). The Ministry of Health of the Republic of Indonesia reports that 97% of malaria cases in Indonesia occur in Papua, where malaria is endemic and common, as evidenced by an API value (Annual Parasite Index) greater than 5/1000 population (Kemenkes, 2018). Geographic conditions, population characteristics, the presence of vectors, and inadequate health services also contribute to malaria transmission (Hasyim, Dale, Groneberg, Kuch, & Müller, 2019; Bamou et al., 2021; Meireles, De Souza Sampaio, Monteiro, & Goncalves, 2020). Consequently, malaria cases occur throughout the year (Lawpoolsri et al., 2019) and people living in endemic areas can potentially suffer from recurrent malaria. Previous research has found that 16% of malaria cases in endemic areas were recurrent episodes (Lawpoolsri et al., 2019). This finding is supported by other studies showing that the number of recurrent malaria episodes within 5 years can reach 5–16 episodes (Rono et al., 2015); these episodes occur in many children, although the incidence decreases with age (Eldh et al., 2020).

The incidence of recurrent malaria episodes is influenced by various factors. These include demographic factors such as age, gender, ethnicity, and occupation, as well as family history of suffering from malaria, which has been previously reported as risk factor (Lawpoolsri et al., 2019). Recurrent malaria is also reportedly associated with repeated infections caused by all types of *Plasmodium* (Rono et al., 2015; Taylor et al., 2019). Malaria recurrence is also related to vector interaction, treatment effectiveness (involving dosing accuracy), and control strategies related to the prevention of *Plasmodium* infection such as insecticide treated nets (ITNs) and indoor residual spraying (IRS) (Daher et al., 2019; Finda et al., 2019; Taylor et al., 2019).

The condition of patients with recurrent malaria episodes can be categorized into several states, during which patients who have had malaria can potentially be re-infect with the disease. Malaria has also different characteristics in children and adults due to the differences in immunity, health habits, the intensity of interaction with vectors, discipline in adherence to treatment, and the understanding of malaria and how to avoid it (Finda et al., 2019). Therefore, it is important to study the resulting differences in disease characteristics, in order to provide appropriate treatment and implement proper control strategies. It is necessary to model the transition of malaria incidence in each age group to estimate the transition intensities and probabilities. One model that is commonly used in such epidemiological problems is the Markovian multiple-state model. A study investigated the clinical signs of malaria infections by *Plasmodium falciparum* using a three-state Markov model includes the states of non-infected, infected without clinical sign, and infected with clinical sign (Richard, Richardson, & Maccario, 1993). This model was used to analyze the impact of an intervention trial using insecticide-treated mosquito nets for children. Gaudart et al. assessed environmental effects on malaria transmission models using the SIRS-type temporal transmission model; they used observations from the 15-day composite vegetation index (NDVI) to simulate extrinsic variables from the hidden Markov chain model (Gaudart et al., 2009). Khan et al. formulated and analyzed a stochastic epidemic model for the dynamics of transmission of a single dengue virus strain, using a stochastic model constructed from continuous time Markov chains (CTMC) (Khan, Hassan, & Imran, 2013). Furthermore, a study in 42 malaria-endemic countries in Sub-Saharan Africa models the potential public health impact of the RTS,S malaria vaccine candidate. With three levels of malaria transmission intensity and six levels of malaria immunity, this study built an individual-based Markov cohort model (Sauboin, Van Bellinghen, Van De Velde, & Van Vlaenderen, 2015). Another clinical study of malaria among the student population of Masinde Muliro University of Science and Technology has modeled transitions in the patient's disease status each time they visit the clinic. Every change in a student's malaria symptoms that became a reference for status transitions was modeled using the Bayesian Hidden Markov Model (Mbete, Nyongesa, & Rotich, 2019). Cortes et al. conducted a study related to the influenza pandemic in Egypt, which assumed the input data in the SIR model. These model consisted of the initial conditions, the contagion, and recovery states; in the transition matrix, these served a random variable, not as deterministic constant. These researchers estimated the first probability density function of its subpopulations as the appropriate state of the Markov chain (susceptible, infected, and recovered) (Cortés, El-Labany, Navarro-Quiles, Selim, & Slama, 2020). A recent study has shown that the probability of disease outbreaks that are affected by seasonal changes in temperature, humidity, and rainfall can be approximated using a solution of the backward Kolmogorov differential equation in the continuous-time Markov chain model (Nipa, Jang, & Allen, 2021).

Considering the usefulness of the Markovian multiple-state model in modeling epidemiological problems, we aim to model the characteristics of malaria in Timika, Indonesia, especially in the case of recurrent episodes. We have divided the model into four; a combination of two age groups and two types of patient adherence to protocol and treatment. First, we present the number of malaria cases for each species (*Plasmodium falciparum*, *Plasmodium vivax*, or a mix of both species). Second, we divide the incidence into four compartmental models by identifying the patient's status at the time of the visit to the health center. Furthermore, we estimate the transition intensities and probabilities of the status of malaria-infected patients, using the Kolmogorov forward differential equation in the continuous-time Markov multiple-state model; we

then interpret the results. In the final section, we perform simulations with several control strategies to reduce the probability of the patient being infected and increase the probability of the patient recovering.

2. Materials and methods

2.1. Study area

This research was conducted in Naena Muktipura Village, Timika, Papua, Indonesia. Naena Muktipura is one of seven villages in the Iwaka District working area and is a malaria-endemic village located in the lowlands. The village area is surrounded by forests and swamps with high rainfall throughout the year; it had population of 1492 in 2020, dominated by men. The productive age group in this area is 15–64 years of age, with most of the population working as farmers, planters, and traders. The ethnicity that inhabits this village consists of Timika natives and migrants who have come from various regions in Indonesia, with the largest ethnic groups being Javanese and South-East Nusa.

The distance from the village to the city center is around 50 km, while the distance to the main health center in Iwaka District is about 20 km, the villagers check themselves more often at the Naena Muktipura sub-health center. The most common type of disease diagnosed is malaria, and cases are constantly present throughout the year. The most identified types of *Plasmodium* are *Plasmodium falciparum* and *Plasmodium vivax*.

2.2. Collected data

We present here a retrospective study using secondary data from patients who were tested for malaria at the Naena Muktipura sub-health center from March 2020 to March 2021. The process of collecting medical record data was carried out for 2 months. Blood smear examination was carried out at this sub-health center, using a blood smear or RDT. The patient medical record data used in this study are age, malaria test results, and *Plasmodium* species.

Furthermore, this study divides age into two groups according to a grouping established by the WHO, which classifies age under 24 years as young adults and over 24 years as adults (WHO, 2021). These classifications are also intended to yield a more accurate number of sample calculations for each group according to the limitation of the data, especially in the younger age group which is usually classified as the under 5 years. Table 1 presents the operational definitions used in this study.

Fig. 1 illustrates the data used in this study. The total numbers of incidences in under-24 and over-24 age groups are 456 and 508, respectively. The most common type of incidence is Undetected Parasitaemia in the both age groups. Fig. 1 also shows that the highest numbers of Confirmed incidences are caused by *Plasmodium falciparum*, followed by *Plasmodium vivax* and a combination of both species.

Table 1
Operational definitions in malaria patients.

| Variable | Operational definitions |
|-------------------------|---|
| Undetected Parasitaemia | A person who shows symptoms of malaria although no <i>Plasmodium</i> is found in the blood either by microscopic examination or RDT |
| Confirmed | <i>Plasmodium</i> is found in the blood by either microscopic examination or RDT |
| Aparasitaemic | A condition marked by the absence of a visit to the public health center after 14 days is confirmed |

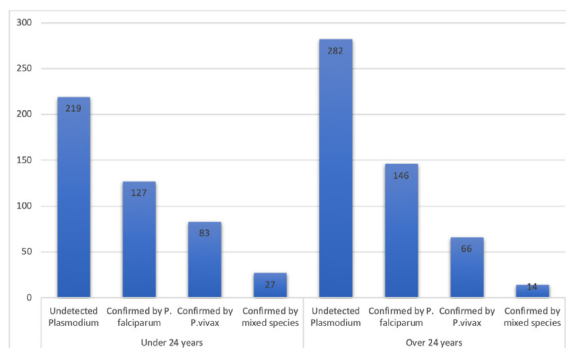

Fig. 1. The number of malaria incidences by species.

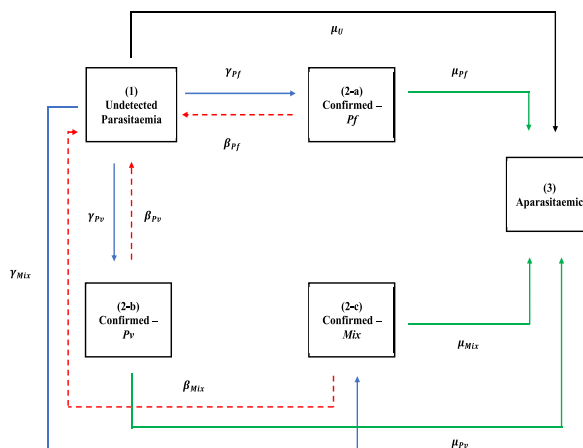

Fig. 2. Compartment model for malaria recurrences in Timika.

2.3. Ethics approval and participant consent

This study was approved by the Health Ethics Committee of the Faculty of Medicine Universitas Islam Indonesia with number 2/Ka.Kom.Et/70/KE/VI/2021 including a waiver for participant consent. We have also obtained written consent from the Timika district health office and the head of the Naena Muktapura sub-health center to conduct this research. All patient data used in this study are kept confidential, where every patient data is made in coding form and only the main researcher can access the data.

3. Methods

3.1. A Markovian multiple state model

The incidence of malaria recurrences in Timika from March 2020 to March 2021 was high, resulting from infections by *Plasmodium falciparum*, *Plasmodium vivax*, and or both species together. The mathematical model for malaria recurrences is constructed using five groups of patients: (1) Undetected Parasitaemia U , (2-a) Confirmed infection by *P. falciparum* C_{Pf} , (2-b) Confirmed infection by *P. vivax* C_{Pv} , (2-c) Confirmed infection by both species C_{Mix} , and (3) Aparasitaemic A . The set of transitions between each compartment is shown in Fig. 2.

However, due to the limitation of the representative samples from malaria incidences with each infecting species, we simplify the compartment of the confirmed incidences, which had originally been divided by species within compartment (2), Confirmed C . Table 2 describes the variables and the parameters involved in the model.

Let $[0, T]$ be a fixed finite time parameter and a state space $\{X(t)\}_{t \in [0, T]}$ which has Markovian properties. A multiple-state model for repeated malaria incidences has a state space $X = \{1 = U, 2 = C, 3 = A\}$ with an assumption that $X(0) = 1$. Suppose that $P_{ij}(z, t) = P(X(t) = j | X(z) = i)$ is a transition probability of state i at time z to state j at time t . The corresponding transition intensities are described as follows:

Table 2
Definitions of the model's variables and parameters.

| Notation | Description | Unit |
|----------------|---|--------|
| U | The number of incidences in the Undetected Parasitaemia state | people |
| C | The number of incidences in the Confirmed state | |
| A | The number of incidences in the Aparasitaemic state | |
| γ_{Pf} | Transition intensities from U to the C_{Pf} state | 1/days |
| γ_{Pv} | Transition intensities from U to the C_{Pv} state | |
| γ_{Mix} | Transition intensities from U to the C_{Mix} state | |
| β_{Pf} | Transition intensities from C_{Pf} to the U state | |
| β_{Pv} | Transition intensities from C_{Pv} to the U state | |
| β_{Mix} | Transition intensities from C_{Mix} to the U state | |
| μ_U | Transition intensities from U to the A state | |
| μ_{Pf} | Transition intensities from C_{Pf} to the A state | |
| μ_{Pv} | Transition intensities from C_{Pv} to the A state | |
| μ_{Mix} | Transition intensities from C_{Mix} to the A state | |
| $P_{ij}(z, t)$ | Transition probability from state i to j | — |

$$Q = \begin{pmatrix} -(\gamma + \mu_U) & \gamma & \mu_U \\ \beta & -(\beta + \mu_C) & \mu_C \\ 0 & 0 & 0 \end{pmatrix} \tag{1}$$

where γ denotes the transition intensities of state $i = 1$ to state $j = 2$, $\beta = p_{Pf}\beta_{Pf} + p_{Pv}\beta_{Pv} + p_{Mix}\beta_{Mix}$ denotes the transition intensities of state $i = 2$ to state $j = 1$, and $\mu_C = p_{Pf}\mu_{Pf} + p_{Pv}\mu_{Pv} + p_{Mix}\mu_{Mix}$ denotes the transition intensities of state $i = 2$ to $j = 3$, p_{Pf} , p_{Pv} and p_{Mix} are the proportions of Confirmed infection by *P. falciparum*, *P. vivax*, and by both species, respectively. The proportion is calculated from the sample size of each species.

We perform a fitting distribution over the set of days a patient spent in a given state to estimate the transition intensities in each of the defined states. Suppose that T_{ij} is a random variable representing the number of days that a patient spent in given state i before moving to state j , $i \neq j$. Assuming that the transition intensities $\Omega_{ij} = \{\gamma, \mu_U, \beta, \mu_C\}$ is time-independent, then Ω_{ij} can be estimated using a maximum likelihood estimation with the log likelihood function, as follows:

$$\log L(\Omega_{ij}; T_{ij}) = \log \left(\prod_{i=1}^3 \prod_{j=1}^3 f(t_{ij}; \Omega_{ij}) \right) \tag{2}$$

Ω_{ij} is obtained by solving the following formula.

$$\hat{\Omega}_{ij} = \arg \max_{\Omega_{ij}} \log L(\Omega_{ij}; T_{ij}) \tag{3}$$

Furthermore, using the Kolmogorov forward differential equations (Baione & Levantesi, 2014; Haberman & Pitacco, 1998), we obtain a set of simultaneous differential equations of the transition intensities $P_{ij}(z, t)$:

$$\frac{dP_{11}(z, t)}{dt} = -(\gamma + \mu_U)P_{11}(z, t) \tag{4}$$

$$\frac{dP_{12}(z, t)}{dt} = \gamma P_{11}(z, t) - (\beta + \mu_C)P_{12}(z, t) \tag{5}$$

$$\frac{dP_{13}(z, t)}{dt} = \mu_U P_{11}(z, t) + \mu_C P_{12}(z, t) \tag{6}$$

$$\frac{dP_{21}(z, t)}{dt} = \beta P_{22}(z, t) - (\gamma + \mu_U)P_{21}(z, t) \tag{7}$$

$$\frac{dP_{22}(z, t)}{dt} = -(\beta + \mu_C)P_{22}(z, t) \tag{8}$$

$$\frac{dP_{23}(z, t)}{dt} = \mu_U P_{21}(z, t) + \mu_C P_{22}(z, t) \tag{9}$$

The solutions to the transition probabilities of Equations (4)–(9) given as follows:

$$P_{11}(z, t) = \exp \left\{ - \int_z^t (\gamma + \mu_U) du \right\} \tag{10}$$

$$P_{12}(z, t) = \int_z^t \gamma P_{11}(z, u) P_{22}(u, t) du \tag{11}$$

$$P_{13}(z, t) = 1 - P_{11}(z, t) - P_{12}(z, t) \tag{12}$$

$$P_{22}(z, t) = \exp \left\{ - \int_z^t (\beta + \mu_C) du \right\} \tag{13}$$

$$P_{21}(z, t) = \int_z^t \beta P_{22}(z, u) P_{11}(u, t) du \tag{14}$$

$$P_{23}(z, t) = 1 - P_{21}(z, t) - P_{22}(z, t) \tag{15}$$

Based on the solutions to the transition probabilities obtained above, the probability of a repeated malaria incidence can be estimated using the transition intensities of the Confirmed state to the Undetected Parasitaemia (at a rate of β) and to the Aparasitaemic state (at a rate of μ_C). Then, using a Bayes concept, we estimate the probability of a person being infected again by *Plasmodium falciparum*, *Plasmodium vivax*, or both species together if they are ever in Confirmed state.

3.2. Control strategy

Based on the malaria control strategy that continues to be developed, we carried out control simulations for prevention using insecticide-treated nets and indoor residual spraying. Insecticide-treated nets (ITNs) have proven to be effective for malaria prevention (Njumkeng et al., 2019). Apinjoh et al. have shown that the use of ITNs has been effective in reducing the prevalence of malaria cases, especially in the South-West Region of Cameroon (Apinjoh et al., 2015). In addition to ITNs, indoor residual spraying (IRS) is a primary method for eliminating malaria (Nájera, González-Silva, & Alonso, 2011). Gimnig et al. have found that IRS reduced malaria prevalence in a moderately high transmission setting in sub-Saharan Africa. (Gimnig et al., 2016).

There has never been a control strategy using ITNs and IRS in Timika, Papua. However, previous studies have shown that the control strategy using ITNs and IRS in high malaria endemic areas can reduce the prevalence rate, mortality rate and positivity rate of malaria (Larsen et al., 2014; Namuganga et al., 2021). Therefore, in this study, we use ITNs and IRS as control strategies to prevent malaria transmission in Timika. We use the control strategy model that has been conducted by Larsen et al. (2014) and Namuganga et al. (2021), assuming that the results of the implementation of malaria control in previous studies generally have the same effect on any endemicity condition.

We use the prevalence rates calculated from previous studies on the prevention control strategies to formulate the parameter for decreasing the transmission rate in our compartment model. Based on studies conducted by Larsen et al. (2014), the coverage of ITNs use varies from > 30% to > 70%. They provided the prevalence rate of the community with and without ITNs and divided it into three age groups; children aged 1–59 months, infants aged 1–11 months, and children aged 12–59 months. However, we use the parameter of the last age group to calculate the ratio of the prevalence rate between areas with and without ITNs and assumed that the parameters in the largest age group are generally applicable to all age groups. Fig. 3 shows the prevalence rate in the areas with and without ITNs based on Larsen et al. (2014)'s study (with some adjustments to facilitate the delivery of information).

Furthermore, the application of IRS both initiation and continuous can reduce the incidence rate ratio of malaria compared to discontinuation of IRS. Previous study conducted by Namuganga et al. (2021) showed that the average of the incidence rate ratio at the initiation of the IRS application is 0.37 and after the application is carried out continuously, the incidence rate ratio decreases to 0.207. This shows a significant decrease in the incidence rate because the discontinuation of the IRS application caused the incidence rate to rise to 5.5. Based on the effect of using ITNs and IRS on reducing the incidence or prevalence rate, we assume that these two controls can be applied to reduce the incidence of malaria in Timika, Papua.

In this study, we carried out simulations related to the effect of using ITNs with various coverage and IRS both at the beginning of use and continuous use on reducing the incidence of malaria to be applied to the real malaria incidence data in

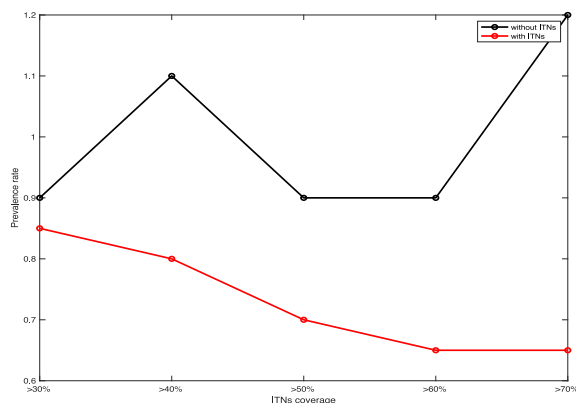

Fig. 3. Prevalence rate in areas with and without ITNs.

Table 3
Control parameters.

| Description | Parameter | Value | Ref. |
|---|-----------------------|-----------|-------------------------|
| Ratio of the prevalence rate between areas with and without ITNs coverage | | | |
| a. > 30% coverage | $\kappa_{P_{1,30}}$ | 0.85/0.9 | Larsen et al. (2014) |
| b. > 40% coverage | $\kappa_{P_{1,40}}$ | 0.8/1.1 | |
| c. > 50% coverage | $\kappa_{P_{1,50}}$ | 0.7/0.9 | |
| d. > 60% coverage | $\kappa_{P_{1,60}}$ | 0.65/0.9 | |
| e. > 70% coverage | $\kappa_{P_{1,70}}$ | 0.65/1.2 | |
| Ratio of the prevalence rate between areas with and without IRS coverage | | | |
| a. IRS initiated | $\kappa_{P_{2,init}}$ | 0.37/5.5 | Namuganga et al. (2021) |
| b. IRS sustained | $\kappa_{P_{2,sust}}$ | 0.207/5.5 | |

Timika, Papua. The decrease in the incidence rate is illustrated by a decrease in the transition probability from both Undetected to Confirmed conditions and in Confirmed Recurrent conditions. Therefore, the control parameters defined are the effect of the use of both controls on the incidence rate and are provided in Table 3.

Suppose that the control parameters are κ_P and κ_C for prevention and cure, respectively; then, we have a new transition intensities matrices, as follow:

$$Q^* = \begin{pmatrix} -(\gamma\kappa_{P_i} + \mu_U) & \gamma\kappa_{P_i} & \mu_U \\ \beta & -(\beta + \mu_C\kappa_{P_i}^{-1}) & \mu_C\kappa_{P_i}^{-1} \\ 0 & 0 & 0 \end{pmatrix} \tag{16}$$

and

$$Q^{**} = \begin{pmatrix} -(\gamma + \mu_U) & \gamma & \mu_U \\ \beta & -(\beta + \kappa_C) & \kappa_C \\ 0 & 0 & 0 \end{pmatrix} \tag{17}$$

where Q^* and Q^{**} are the transition intensities matrices for the prevention and cure control strategies, respectively.

3.3. Model assessment

Based on the study conducted by Larsen et al. (2014), after all of the analysis, the use of ITNs can reduce the positivity rate by 14% for all coverages. Furthermore, the use of the IRS in the first round for 6 months resulted in a positivity rate of 48.5–72.0%. Meanwhile, the routine use of the IRS resulted in a positivity rate of 23.7–25.9% (Namuganga et al., 2021). Therefore, as a form of validation of the proposed model and control strategy, we evaluate the level of positivity generated by our model which is manifested in the form of transition probabilities, both from Undetected to Confirmed and Confirmed Recurrent based on the information on the decrease in the positivity rate. We evaluate our model at the 5% significance level using z-test and test whether our model gives significant results or not. The null hypothesis is set to test that the average positivity rate of our model is the same as that of the Larsen et al. (2014) and Namuganga et al. (2021) model, and is contrasted with the alternative hypothesis in which the positivity rate of our model is lower than that of the two models. The statistics test used is

$$Z = \frac{\hat{p} - p_0}{\sqrt{\frac{p_0(1-p_0)}{n}}} \tag{18}$$

where \hat{p} is the positivity rate of our model which is expressed in the form of transition probabilities from Undetected to Confirmed and the transition probabilities of Confirmed Recurrent, p_0 is the positivity rate resulted from the use of ITNs and IRS, and n is the sample size.

4. Results and discussion

To estimate the transition intensities, we collected the number of days spent by each patient in state i at time z before moving to state j at time t ; these data are provided it in Figs. 4 and 5 for under-24 and over-24 groups, respectively.

Based on the distribution fitting on the number of days spent by patients in each state, we obtain the estimation of the transition intensities, which is provided in Table 4.

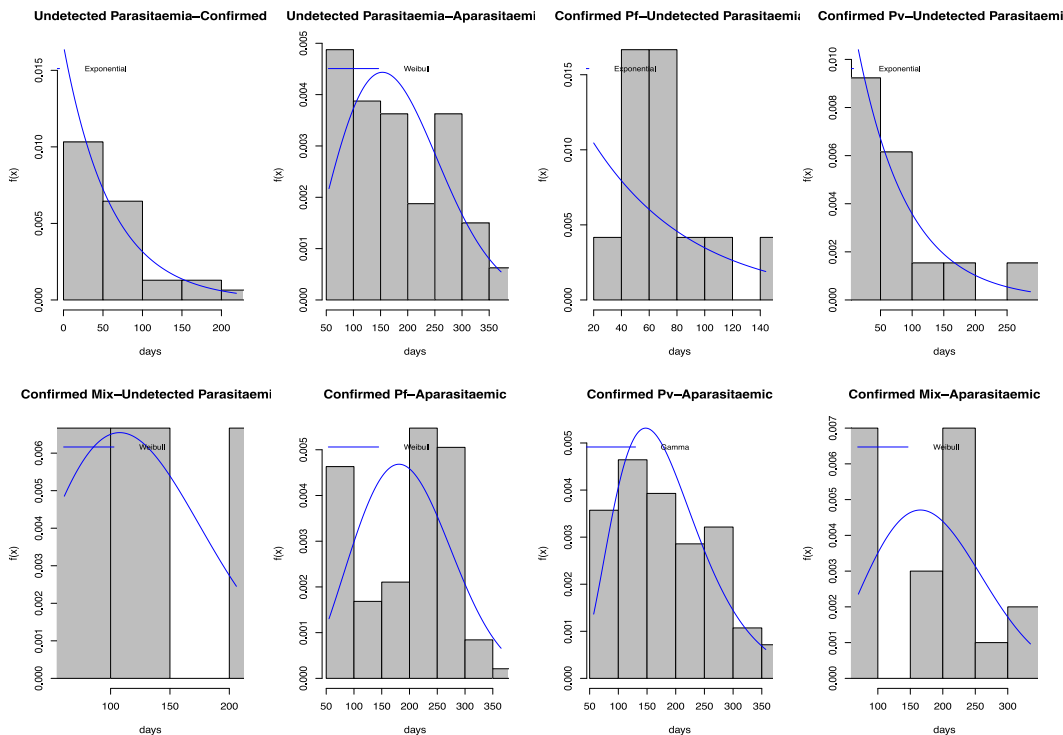

Fig. 4. Distribution of the number of days spent by patients under 24 years.

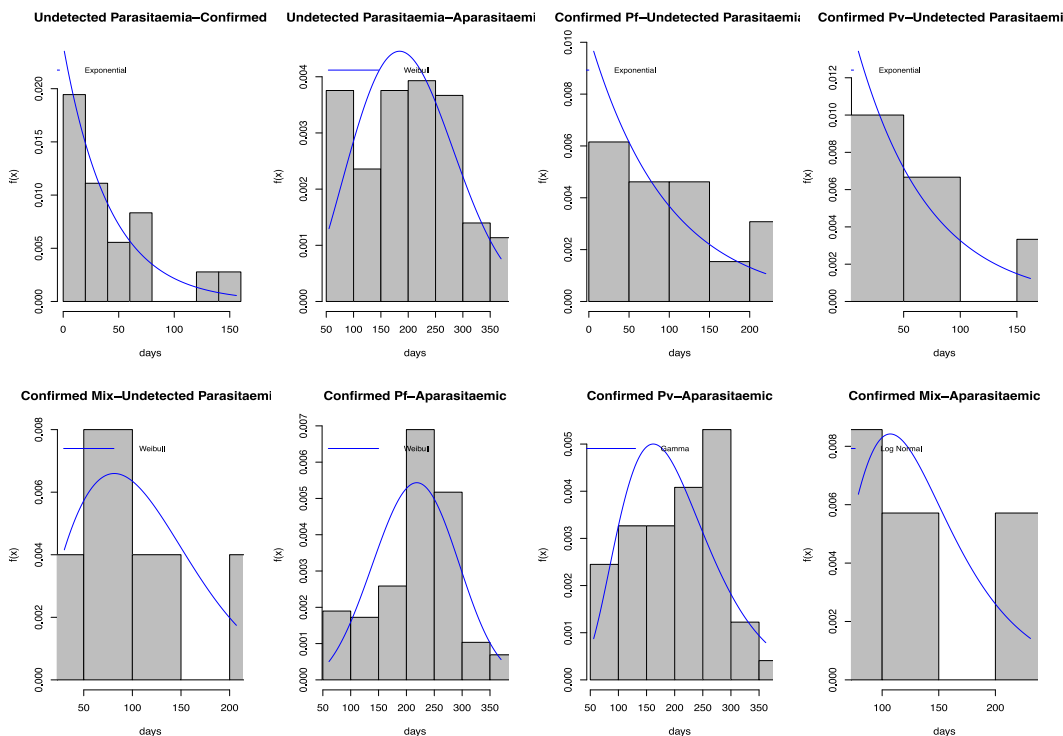

Fig. 5. Distribution of the number of days spent by patients over 24 years.

Furthermore, Table 5 provides the proportion of Confirmed infection by *P. falciparum*, *P. vivax*, and by both species. It also provides the value of parameter β and μ_C which are the weighted transition intensities based on the proportion of the three species.

According to the model construction, there are four models in total, for each combination of the two age groups and the two types of patient adherence to the treatment protocol. A significant difference is shown by the estimated transition intensity from the Confirmed to the Aparasitaemic state (μ_C) in the two types of patient adherence. The estimated μ_C in patients who did not adhere was much lower than that of those patients who did adhere. This shows that the speed of recovery among patients who adhere to the protocol and treatment is greater than the speed among non-adherent patients. These two assumptions are then used to estimate and analyze the transition probabilities obtained from Equations (10)–(15).

The graph in the first row in Fig. 6 shows that the transition probability of the patients in the Undetected Parasitaemia state remaining in the same state over a certain period of time becomes smaller in all age groups. The presence of Parasitaemia in the blood is called parasitaemia; in this condition, the number of organism/ μl of blood varies greatly between individuals. In endemic areas, the condition of Undetected Parasitaemia does not rule out the presence of *Plasmodium* infection. On microscopic examination and RDT, if the number of *Plasmodium* is < 5 parasites/ μl , then the presence of *Plasmodium* is difficult to detect (Carrasco-Escobar et al., 2017). This condition is known as a malaria incidence with low-density parasitaemia; more sensitive tests such as PCR are necessary to detect *Plasmodium* (Arwati, Yotopranoto, Rohmah, & Syafruddin, 2018; Hartley et al., 2020). Low-density parasitaemia may be characterized by fever-like symptoms, as demonstrated in this study. These symptoms may stem from infection with *Plasmodium* or a virus; they disappear as the infection diminishes. The results of this study indicate that the probability of the transition from Undetected Parasitaemia to remaining in the same condition within a certain period of time decreases over time. If the condition of Undetected Parasitaemia stems from low-density parasitaemia, the density of the parasites will fall, leading to a mild disease without complications (Hartley et al., 2020).

The second graph in Fig. 6 shows that the probability of transition from Undetected Parasitaemia to Confirmed state is greater in the non-adherent group; the transition rate is faster in the over-24 age group. Studies show that malaria is suffered more commonly by this age group (Jenkins et al., 2015). A study in Kulonprogo Yogyakarta suggests that work, activity, and behavior at night were associated with malaria (Bamou et al., 2021; Basseri, Abai, Raeisi, & Shahandeh, 2012; Finda et al., 2019; Sulistyawati & Fitriani, 2019). Risky work requires a person to be active until night, which can increase the possibility of contact with malaria vectors (Finda et al., 2019). These findings align with the results of our own study, which finds that the transition probabilities from the Undetected Parasitaemia state to the Confirmed state is also greater in the group that engages in activities that can increase the risk of malaria transmission. Moreover, there are two real possible conditions for those in the Undetected Parasitaemia state: either low-density parasitaemia or negative *Plasmodium*. If a patient's real condition is low-density *Plasmodium*, they are more likely to move from the Undetected Parasitaemia state to the Confirmed state over time. Meanwhile, if a patient's real condition is negative *Plasmodium*, they are more likely to move to a Aparasitaemic state over time. This also confirms the results shown in the first graph in Fig. 6, in which both possibilities reduce the patient's probability of remaining in the Undetected Parasitaemia state.

The transition probabilities from Undetected Parasitaemia to the Aparasitaemic state, as shown by the graph in the third row in Fig. 6, are greater in the adherent group, whereas the transition intensities are faster in the under-24. The Undetected Parasitaemia state, which is associated with low-density parasitemia, is generally characterized by a mild or even asymptomatic infection (Hartley et al., 2020; Pava et al., 2016). If the patient avoids malaria risk behaviors, they can avoid exposure to *Plasmodium*, which can move a person into the Confirmed state. In adults, the rate of recovery is influenced by several factors, such as risky behaviors (or the avoidance thereof) and the presence of other systemic diseases (White, 2011). Furthermore, people in the under-24 age group have low mortality and rarely have comorbidities. Therefore, this age group have a faster aparasitaemic rate than the over-24 age group.

The first graph in Fig. 7 shows that the transition probabilities from Confirmed to the Undetected Parasitaemia state increase in all age groups over time; the rate of transition is faster in the non-adherent group. If a patient with uncomplicated malaria does not comply with taking medication according to the guidelines, the levels of parasites in the blood are generally low, and 1 day of antimalarial treatment alone can eliminate complaints (Challenger, Bruxvoort, Ghani, & Okell, 2017). However, this keeps the parasite from being completely eliminated, thereby leading to a recurrence characterized by mild symptoms and low parasitemia in which the parasite cannot be detected by microscopic examination or RDT (Undetected Parasitaemia). This condition could be caused by incorrect prescribing practices, suboptimal drug quality and parasite resistance (Bate, Coticelli, Tren, & Attaran, 2008; Douglas et al., 2017; Riley, Dellicour, Ouma, Kioko, Ter, Duru, Witkowski, & Ménard, 2016; Kuile, Omar, Kariuki, Buff, Desai and Gutman, 2016). A patient who shows symptoms of malaria and receives immediate treatment is at a higher risk of non-adherence than a person who has symptoms of malaria but does not seek immediate treatment. However, someone who immediately receives treatment after symptoms appear and is diagnosed with malaria has a low chance of transmitting malaria (Challenger et al., 2019). Our study shows that the transition probability from Confirmed to the Undetected Parasitaemia state increased over time in the non-adherent group. This shows that low medication adherence can prevent *Plasmodium* in the blood from being eliminated properly, leading to the condition of Undetected Parasitaemia. According to (Banek et al., 2021), people who receive treatment immediately after experiencing symptoms of malaria are at a greater risk of non-adherence than people who have symptoms of malaria but do not seek immediate treatment. This behavior can also keep *Plasmodium* from being completely eliminated, leading to a recurrence. However, a patient who immediately receives treatment after symptoms appear and is diagnosed with malaria has a low

Table 4
Transition intensities estimates.

| Parameter | Estimates | |
|---------------------|-----------|---------|
| | Under-24 | Over-24 |
| $\hat{\gamma}$ | 0.01662 | 0.02410 |
| $\hat{\mu}_U$ | 0.00553 | 0.00498 |
| $\hat{\beta}_{Pf}$ | 0.01026 | 0.01027 |
| $\hat{\beta}_{Pv}$ | 0.01570 | 0.01571 |
| $\hat{\beta}_{Mix}$ | 0.00908 | 0.00910 |
| $\hat{\mu}_{Pf}$ | 0.00525 | 0.00460 |
| $\hat{\mu}_{Pv}$ | 0.00543 | 0.00500 |
| $\hat{\mu}_{Mix}$ | 0.00544 | 0.00791 |
| $\hat{\mu}_C$ | 0.07143 | 0.07143 |

$\hat{\mu}_C$ is the estimates for model with the assumption of patients' adherence to protocol and treatment.

Table 5
Proportion of Confirmed infection by species and the weighted transition intensities.

| Species | Proportion | |
|----------------------|------------|---------|
| | Under-24 | Over-24 |
| <i>P. falciparum</i> | 0.5359 | 0.6460 |
| <i>P. vivax</i> | 0.3502 | 0.2920 |
| Mixed | 0.1139 | 0.0619 |

| Parameter | Estimates | |
|---------------|-----------|---------|
| | Under-24 | Over-24 |
| β | 0.01204 | 0.01178 |
| $\hat{\mu}_C$ | 0.00533 | 0.00492 |

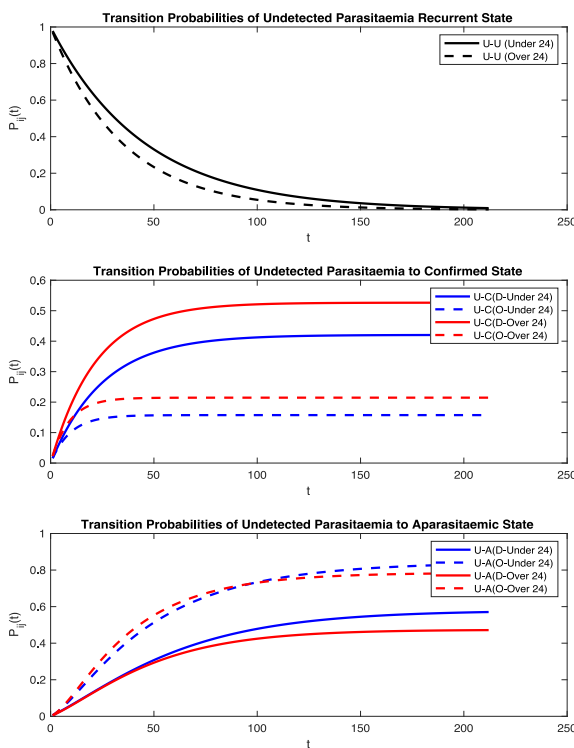

Fig. 6. Transition probabilities from Undetected Parasitaemia to other states.

chance of transmitting malaria (Challenger et al., 2019). If the patient adheres to treatment, the probability to be in Aparasitaemic state is greater than it is among the non-adherent. This causes the transition probabilities from Confirmed to the Undetected Parasitaemia state to decrease over time.

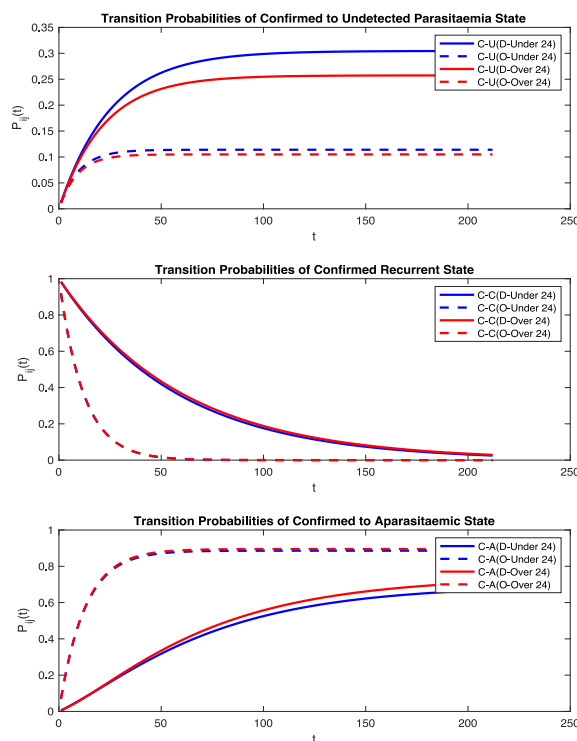

Fig. 7. Transition probabilities from Confirmed to other states.

The transition probabilities from Confirmed to the Aparasitaemic state, as shown by the third graph in Fig. 7, increase in all age groups; the rate of transition is higher in the treatment-adherent group and in the over-24 age group. For this age group, knowing the importance of malaria treatment, adhering to medication treatment, and avoiding contact with vectors after confirmation of malaria are all behaviors that have explain why this age group has a greater possibility of recovering (along with a faster recovery time) than the under-24 age group. Unlike the situation with the transition from Undetected Parasitaemia to the Aparasitaemic state, the undetected malaria patients feel that they are not sick, so they continue to engage in activities that involve contact with vectors. In contrast, in the Confirmed condition, patients realize that they are infected by malaria and are therefore more disciplined in avoiding contact with vectors.

The second graph in Fig. 7 shows that the transition probabilities of the Confirmed Recurrent state decrease over time in all age groups for both fadherent and non-adherent patients. These results are in accordance with those of study (Daher et al., 2019) finding no difference in the time and frequency of recurrences between adherent and non-adherent patients. However, the rate of transition is faster in the treatment-adherent group, indicating that the recurrence of Plasmodium infection is correlated to treatment supervision—malaria recurrence increases in the absence of treatment supervision and decreases with treatment supervision conducted by health workers (Dinely et al., 2021). Consistently taking medication according to the guidelines leads to the elimination of Plasmodium from the bloodstream. In turn, this prevents transmission from confirmed patients to healthy people through vector intermediaries. Linking the results shown in the second graph to those in the first and third graphs in Fig. 7, if a patient has a confirmed malaria infection and receives treatment (to which they are either adherent and non-adherent), it is possible that the condition of the patient will change to Aparasitaemic or low-density parasitaemia (Undetected Parasitaemia), as opposed to remaining in the Confirmed state.

One of the control strategies in preventing malaria is to use ITNs. Based on information from the health office and the Limau Asri health center, it is known that the ITNs application has never been carried out in Naena Muktipura Village; therefore, we try to simulate if an attempt is made to use ITNs and study how it affects the patient's condition. Fig. 8 shows the simulation of the control strategy for the prevention of malaria disease using ITNs with 30%, 40%, 50%, 60%, and 70% coverage levels. With the use of ITNs, the prevalences of transitions from Undetected Parasitaemia to the Confirmed state is decreasing, as is the prevalence of Confirmed-state patients remaining in the Confirmed state. This demonstrates that the use of ITNs can prevent contact between humans and vectors (Moiroux, Chandre, Hougard, Corbel, & Pennetier, 2017). The results of this study align with those of the research performed by Njumkeng et al. (Njumkeng et al., 2019), who conclude that, as ITNs coverage increases, the prevalence of malaria decreases. Greater use of ITNs by individuals leads to more effective protection for the community. Thus, the effectiveness of ITNs is strongly influenced by individual actions (Levitz et al., 2018). Long-term and mid-term use of ITNs can also reduce the incidence and mortality of malaria (Ferreira, Lyra, Azevedo, Greenhalgh, & Massad, 2017).

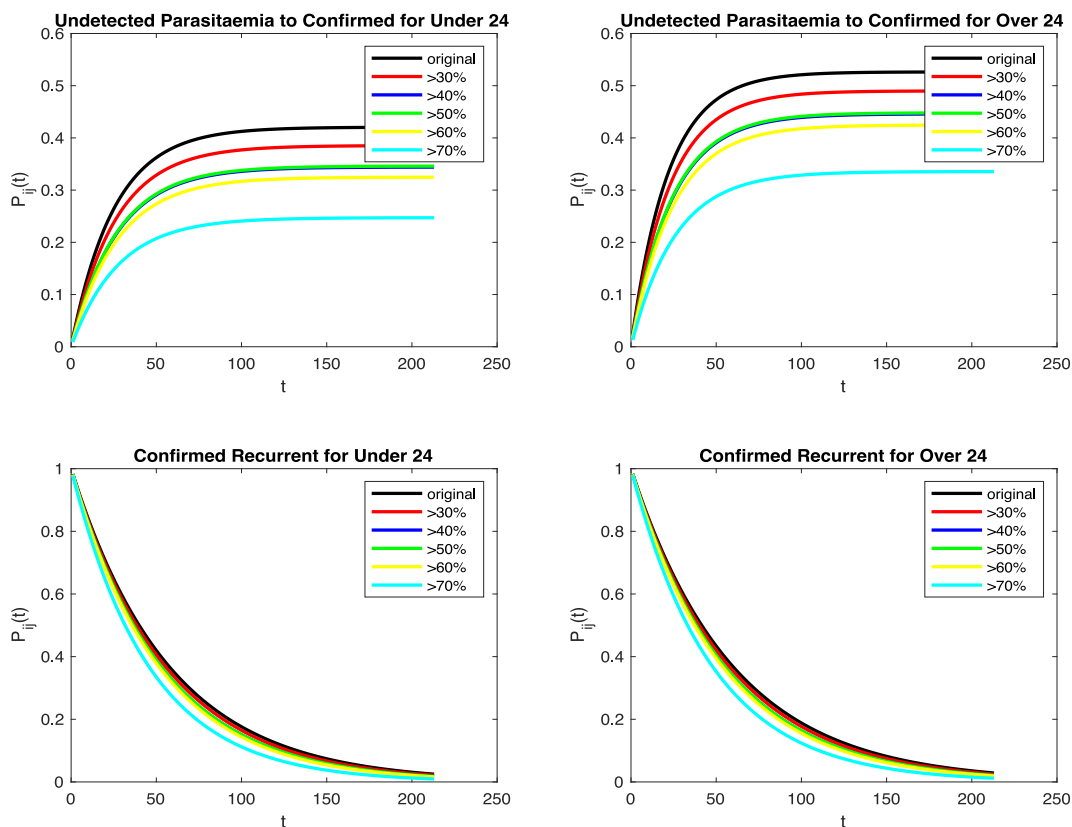

Fig. 8. Transition probabilities with ITNs-based control strategy.

Fig. 9 shows the simulation of a control strategy for preventing malaria disease using IRS. The use of IRS significantly reduced the probability of a transition from Undetected Parasitaemia to a Confirmed state in all age groups, although the transition rate was faster among those over 24 years of age. These results are in line with those of previous studies concluding that the use of IRS can reduce the prevalence and incidence of malaria. The use of this IRS can also reduce the length of *Plasmodium* infection (Kané et al., 2020). This is because IRS can prevent contact with malaria vectors at home, even for those who do not use ITNs while sleeping (Wagman et al., 2021; West et al., 2015). IRS is also suitable for use in areas either high or low malaria endemicity (West et al., 2015).

The estimated probability of transition from the Undetected Parasitaemia state in the original data of this study shows that the malaria incidence was 0.4–0.55 higher than it was with IRS use. These results are reinforced by the finding that non-use of IRS can increase malaria incidence by 5 times (Namuganga et al., 2021). IRS application can provide a protective effect on both an individual and community level, compared to using ITNs only (West et al., 2015).

The probability of a patient in the Confirmed state remaining there decreases in all age groups after using IRS. Keating et al. (Keating et al., 2021) have shown that the use of IRS can reduce the overall malaria incidence. The reduction in malaria incidence in areas that use IRS on an ongoing basis can be 70–85% greater than in areas that do not use IRS (Namuganga et al., 2021; Wagman et al., 2018). The use of IRS is also cheap, safe, and cost-effective, thereby freeing up other funds allocated for malaria treatment for use in control activities and other malaria elimination programs (Bath et al., 2021; Wagman et al., 2018). In addition to providing wider and more effective protection, IRS and ITNs must also be accompanied by monitoring for their impacts on the environment and on malaria vectors themselves (Hii, Hustedt, & Bangs, 2021). In addition, the protective effect of ITNs decreases over the length of their use (Sugiarto, Hadi, Soviana, & Hakim, 2017). Therefore, a combination of various malaria prevention efforts is necessary to eliminate malaria.

Finally, to evaluate our model, we tested the hypothesis of whether the positivity rate resulting from our analysis was within the range of expected positivity levels based on Larsen et al. (2014) and Namuganga et al. (2021)’s model. Table 6 shows the results of the model assessment of our model.

Table 6 shows that all of the results of *p* – value in z-test worth less than the significant level of 0.05 which means that all the tests reject H_0 . The rejection on H_0 means that the positivity rate of our model is less than Larsen et al. (2014) and Namuganga et al. (2021)’s model. Therefore, we can conclude that the control strategies applied to our model give a very good results in reducing the positivity rate of the malaria incidence in Timika, Papua.

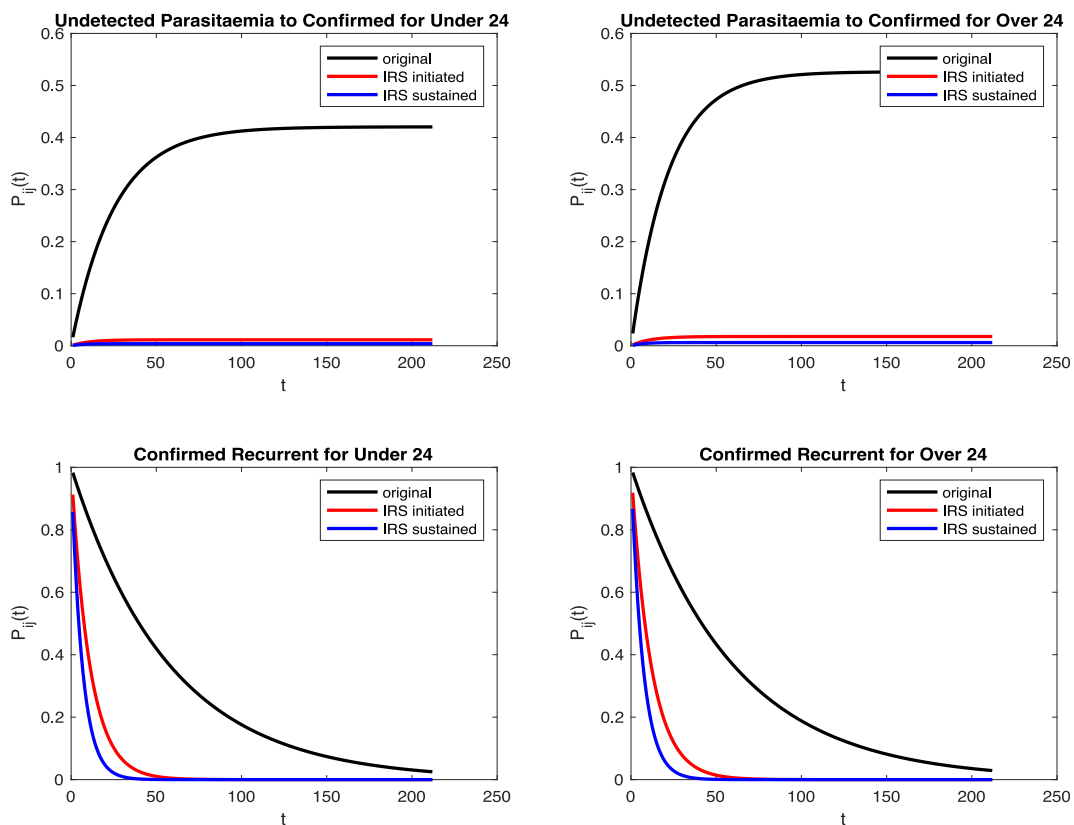

Fig. 9. Transition probabilities with IRS-based control strategy.

Table 6
Model assessment.

| Control strategy | Age group | Transition states | Treatment | z – stat | p – value |
|------------------|-----------|----------------------|----------------|----------|------------------------|
| ITNs-based | Under 24 | Undetected-Confirmed | > 30% coverage | -5.376 | 3.80×10^{-08} |
| | | | > 40% coverage | -5.762 | 4.16×10^{-09} |
| | | | > 50% coverage | -5.744 | 4.62×10^{-09} |
| | | | > 60% coverage | -5.941 | 1.42×10^{-09} |
| | | | > 70% coverage | -6.647 | 1.50×10^{-11} |
| | | Confirmed Recurrent | > 30% coverage | -6.271 | 1.80×10^{-10} |
| | | | > 40% coverage | -6.386 | 8.50×10^{-11} |
| | | | > 50% coverage | -6.381 | 8.81×10^{-11} |
| | | | > 60% coverage | -6.444 | 5.80×10^{-11} |
| | | | > 70% coverage | -6.706 | 9.99×10^{-12} |
| | Over 24 | Undetected-Confirmed | > 30% coverage | -4.350 | 6.81×10^{-06} |
| | | | > 40% coverage | -4.779 | 8.80×10^{-07} |
| | | | > 50% coverage | -4.759 | 9.71×10^{-07} |
| | | | > 60% coverage | -4.984 | 3.11×10^{-07} |
| | | | > 70% coverage | -5.822 | 2.91×10^{-09} |
| | | Confirmed Recurrent | > 30% coverage | -6.171 | 3.39×10^{-10} |
| | | | > 40% coverage | -6.286 | 1.63×10^{-10} |
| | | | > 50% coverage | -6.280 | 1.69×10^{-10} |
| | | | > 60% coverage | -6.343 | 1.13×10^{-10} |
| | | | > 70% coverage | -6.605 | 1.99×10^{-11} |
| IRS-based | Under 24 | Undetected-Confirmed | Initiated | -7.318 | 1.26×10^{-13} |
| | | | Sustained | -2.644 | 4.10×10^{-03} |
| | | Confirmed Recurrent | Initiated | -6.924 | 2.20×10^{-12} |
| | | | Sustained | -2.392 | 8.39×10^{-03} |
| | Over 24 | Undetected-Confirmed | Initiated | -7.256 | 1.99×10^{-13} |
| | | | Sustained | -2.622 | 4.37×10^{-03} |
| | | Confirmed Recurrent | Initiated | -6.884 | 2.91×10^{-12} |
| | | | Sustained | -2.367 | 8.97×10^{-03} |

5. Conclusion

This study shows that the transition probabilities between the Undetected Parasitaemia, Confirmed, and Aparasitaemic states are not always influenced by age, although they are influenced by malaria prevention measures and medication adherence. The rate of transition to recovery in a patient who adheres to prevention and treatment measures is faster than among non-adherent patients, while their probability of re-infection is lower. Our modeling of the control strategies with ITNs and IRS—and with different treatment duration—shows a decrease in the incidence of malaria in the working area of the Naena Muktupura sub-health center. Our findings indicate that the likelihood of recurrences is influenced by adherence to the preventive measures. Therefore, it is necessary to take malaria preventive measures as soon as possible such as using ITNs and IRS to reduce the incidence of malaria in Timika.

CRedit authorship contribution statement

Novyan Lusiyana: Conceptualization, Data curation, Methodology, Interpretation, Writing original draft, Writing, review, and editing. **Atina Ahdika:** Conceptualization, Formal analysis, Methodology, Software, Interpretation, Writing original draft, Writing, review, and editing.

Declaration of interests

The authors declare that they have no known competing financial interests or personal relationships that could have appeared to influence the work reported in this paper.

Acknowledgments

The authors would like to thank all of the staff at the Naena Muktupura Community Health Center, the head of the Limau Asri Public Health Center, and the Timika Health Office, who have assisted tremendously in performing this research. The authors also express their gratitude for the research grant provided by the Faculty of Medicine, Universitas Islam Indonesia Number 600/Dek/70/Adm.Jur/VI/2021 for funding this research.

References

- Apinogh, T. O., Anchang-Kimbi, J. K., Mugri, R. N., Tangoh, D. A., Nyingchu, R. V., Chi, H. F., et al. (2015). The effect of Insecticide Treated Nets (ITNs) on plasmodium falciparum infection in rural and semi-urban communities in the South West Region of Cameroon. *PLoS One*, *10*, 1–13. <https://doi.org/10.1371/journal.pone.0116300>
- Arwati, H., Yotopranoto, S., Rohmah, E. A., & Syafruddin, D. (2018). Submicroscopic malaria cases play role in local transmission in Trenggalek district, East Java Province, Indonesia. *Malaria Journal*, *17*, 1–6.
- Baione, F., & Levantesi, S. (2014). A health insurance pricing model based on prevalence rates: Application to critical illness insurance. *Insurance: Mathematics and Economics*, *58*, 174–184.
- Bamou, R., Rono, M., Degefa, T., Midega, J., Mbogo, C., Ingosi, P., et al. (2021). Entomological and anthropological factors contributing to persistent malaria transmission in Kenya, Ethiopia, and Cameroon. *The Journal of Infectious Diseases*, *223*, S155–S170.
- Banek, K., Webb, E. L., Doogue, E. B., Smith, S. J., Chandramohan, D., & Staedke, S. G. (2021). Factors associated with access and adherence to artemisinin based combination therapy (ACT) for children under five: A secondary analysis of a national survey in Sierra Leone. *Malaria Journal*, *20*, 1–13.
- Basseri, H. R., Abai, M. R., Raeisi, A., & Shahandeh, K. (2012). Community sleeping pattern and anopheline biting in Southeastern Iran: A country earmarked for malaria elimination. *The American Journal of Tropical Medicine and Hygiene*, *87*, 499–503.
- Bate, R., Coticelli, P., Tren, R., & Attaran, A. (2008). Antimalarial drug quality in the most severely malarious parts of Africa - a six country study. *PLoS One*, *3*, 3–5. <https://doi.org/10.1371/journal.pone.0002132>
- Bath, D., Cook, J., Govere, J., Mathebula, P., Morris, N., Hlongwana, K., et al. (2021). Effectiveness and cost-effectiveness of reactive, targeted indoor residual spraying for malaria control in low-transmission settings: A cluster-randomised, non-inferiority trial in South Africa. *The Lancet*, *397*, 816–827. [https://doi.org/10.1016/S0140-6736\(21\)00251-8](https://doi.org/10.1016/S0140-6736(21)00251-8). URL:.
- Carrasco-Escobar, G., Miranda-Alban, J., Fernandez-Miñoque, C., Brouwer, K. C., Torres, K., Calderon, M., et al. (2017). High prevalence of very-low Plasmodium falciparum and Plasmodium vivax parasitaemia carriers in the Peruvian Amazon: Insights into local and occupational mobility-related transmission. *Malaria Journal*, *16*, 1–15.
- Challenger, J. D., Bruxvoort, K., Ghani, A. C., & Okell, L. C. (2017). Assessing the impact of imperfect adherence to artemether-lumefantrine on malaria treatment outcomes using within-host modelling. *Nature Communications*, *8*. <https://doi.org/10.1038/s41467-017-01352-3>. URL:.
- Challenger, J. D., Gonçalves, B. P., Bradley, J., Bruxvoort, K., Tiono, A. B., Drakeley, C., et al. (2019). How delayed and non-adherent treatment contribute to onward transmission of malaria: A modelling study. *BMJ Global Health*, *4*, 1–11. <https://doi.org/10.1136/bmjgh-2019-001856>
- Cortés, J. C., El-Labany, S. K., Navarro-Quiles, A., Selim, M. M., & Slama, H. (2020). A comprehensive probabilistic analysis of approximate SIR-type epidemiological models via full randomized discrete-time Markov chain formulation with applications. *Mathematical Methods in the Applied Sciences*, *43*, 8204–8222.
- Daher, A., Silva, J. C., Stevens, A., Marchesini, P., Fontes, C. J., Ter Kuile, F. O., et al. (2019). Evaluation of plasmodium vivax malaria recurrence in Brazil 11 medical and health sciences 1117 public health and health services. *Malaria Journal*, *18*, 1–10.
- Dinelly, K. M. O., Vitor-Silva, S., Brito-Sousa, J. D., Sampaio, V. S., Silva, M. G. O., Siqueira, A. M., et al. (2021). Evaluation of the effect of supervised anti-malarial treatment on recurrences of Plasmodium vivax malaria. *Malaria Journal*, *20*, 1–6. <https://doi.org/10.1186/s12936-021-03793-0>. URL:.
- Douglas, N. M., Poespoprodjo, J. R., Patriani, D., Malloy, M. J., Kenangalem, E., Sugiarto, P., et al. (2017). Unsupervised primaquine for the treatment of plasmodium vivax malaria relapses in southern Papua: A hospital-based cohort study. *PLoS Medicine*, *14*, 1–19. <https://doi.org/10.1371/journal.pmed.1002379>

- Duru, V., Witkowski, B., & Ménard, D. (2016). Review article plasmodium falciparum resistance to artemisinin derivatives and piperazine: A major challenge for malaria elimination in Cambodia. *The American Journal of Tropical Medicine and Hygiene*, 95, 1228–1238. <https://doi.org/10.4269/ajtmh.16-0234>
- Eldh, M., Hammar, U., Arnot, D., Beck, H. P., Garcia, A., Liljander, A., et al. (2020). Multiplicity of asymptomatic plasmodium falciparum infections and risk of clinical malaria: A systematic review and pooled analysis of individual participant data. *Journal of Infectious Diseases*, 221, 775–785.
- Ferreira, C. P., Lyra, S. P., Azevedo, F., Greenhalgh, D., & Massad, E. (2017). Modelling the impact of the long-term use of insecticide-treated bed nets on Anopheles mosquito biting time. *Malaria Journal*, 16, 1–11.
- Finda, M. F., Moshi, I. R., Monroe, A., Limwagu, A. J., Nyoni, A. P., Swai, J. K., et al. (2019). Linking human behaviours and malaria vector biting risk in south-eastern Tanzania. *PLoS One*, 14, 1–23.
- Gaudart, J., Touré, O., Dessay, N., Dicko, A. L., Ranque, S., Forest, L., et al. (2009). Modelling malaria incidence with environmental dependency in a locality of Sudanese savannah area, Mali. *Malaria Journal*, 8.
- Gimmig, J. E., Otieno, P., Were, V., Marwanga, D., Abong'o, D., Wiegand, R., et al. (2016). The effect of indoor residual spraying on the prevalence of malaria parasite infection, clinical malaria and anemia in an area of perennial transmission and moderate coverage of insecticide treated nets in western Kenya. *PLoS One*, 11, 1–29.
- Haberman, S., & Pitacco, E. (1998). *Actuarial models for disability insurance* (1st ed.). London: Chapman and Hall.
- Hartley, M. A., Hofmann, N., Keitel, K., Kagoro, F., Moniz, C. A., Mlaganile, T., et al. (2020). Clinical relevance of low-density plasmodium falciparum parasitemia in untreated febrile children: A cohort study. *PLoS Medicine*, 17, 1–21.
- Hasyim, H., Dale, P., Groneberg, D. A., Kuch, U., & Müller, R. (2019). Social determinants of malaria in an endemic area of Indonesia. *Malaria Journal*, 18, 1–11.
- Hii, J., Hustedt, J., & Bangs, M. J. (2021). Residual malaria transmission in select countries of Asia-Pacific region: Old wine in a new barrel. *The Journal of Infectious Diseases*, 223, S111–S142. <https://doi.org/10.1093/infdis/jiab004>
- Jenkins, R., Omollo, R., Ongecha, M., Sifuna, P., Othieno, C., Ongeri, L., et al. (2015). Prevalence of malaria parasites in adults and its determinants in malaria endemic area of Kisumu County, Kenya. *Malaria Journal*, 14, 1–6.
- Kané, F., Keïta, M., Traoré, B., Diawara, S. I., Bane, S., Diarra, S., et al. (2020). Performance of IRS on malaria prevalence and incidence using pirimiphos-methyl in the context of pyrethroid resistance in Koulikoro region, Mali. *Malaria Journal*, 19, 1–9. <https://doi.org/10.1186/s12936-020-03357-8>. URL:..
- Keating, J., Yukich, J. O., Miller, J. M., Scates, S., Hamainza, B., Eisele, T. P., et al. (2021). Retrospective evaluation of the effectiveness of indoor residual spray with pirimiphos methyl (Actellic) on malaria transmission in Zambia. *Malaria Journal*, 20, 1–7. <https://doi.org/10.1186/s12936-021-03710-5>. URL:..
- Kemenkes, R. I. (2018). *Situasi terkini perkembangan program pengendalian malaria di Indonesia tahun 2018*. Technical Report.
- Khan, A., Hassam, M., & Imran, M. (2013). The effects of a backward bifurcation on a continuous time Markov chain model for the transmission dynamics of single strain dengue virus. *Applied Mathematics*, 663–674, 04.
- Larsen, D. A., Hutchinson, P., Bennett, A., Yukich, J., Angiewicz, P., Keating, J., et al. (2014). Community coverage with insecticide-treated mosquito nets and observed associations with all-cause child mortality and malaria parasite infections. *The American Journal of Tropical Medicine and Hygiene*, 91, 950–958. <https://doi.org/10.4269/ajtmh.14-0318>
- Lawpoolsri, S., Sattabongkot, J., Sirichaisinthop, J., Cui, L., Kiattitubtr, K., Rachaphaew, N., et al. (2019). Epidemiological profiles of recurrent malaria episodes in an endemic area along the Thailand-Myanmar border: A prospective cohort study. *Malaria Journal*, 18, 1–11.
- Levitz, L., Janko, M., Mwandagaliwa, K., Thwai, K. L., Likwela, J. L., Tshetu, A. K., et al. (2018). Effect of individual and community-level bed net usage on malaria prevalence among under-fives in the Democratic Republic of Congo. *Malaria Journal*, 17, 1–8. <https://doi.org/10.1186/s12936-018-2183-y>. URL:..
- Mbete, D., Nyongesa, K., & Rotich, J. (2019). Estimation of malaria symptom data set using hidden Markov model. *Asian Journal of Probability and Statistics*, 4, 1–29.
- Meireles, B. M., De Souza Sampaio, V., Monteiro, W. M., & Goncalves, M. J. F. (2020). Factors associated with malaria in indigenous populations: A retrospective study from 2007 to 2016. *PLoS One*, 15, 1–14.
- Moiroux, N., Chandre, F., Hougard, J. M., Corbel, V., & Penetier, C. (2017). Remote effect of insecticide-treated nets and the personal protection against malaria mosquito bites. *PLoS One*, 12, 1–13.
- Nájera, J. A., González-Silva, M., & Alonso, P. L. (2011). Some lessons for the future from the global malaria eradication programme (1955-1969). *PLoS Medicine*, 8.
- Namuganga, J. F., Epstein, A., Nankabirwa, J. I., Mpimbaza, A., Kiggundu, M., Sserwanga, A., et al. (2021). The impact of stopping and starting indoor residual spraying on malaria burden in Uganda. *Nature Communications*, 12, 1–9. <https://doi.org/10.1038/s41467-021-22896-5>. URL:..
- Nipa, K. F., Jang, S. R., & Allen, L. J. (2021). The effect of demographic and environmental variability on disease outbreak for a dengue model with a seasonally varying vector population. *Mathematical Biosciences*, 331, Article 108516.
- Njumkeng, C., Apinjoh, T. O., Anchang-Kimbi, J. K., Amin, E. T., Tanue, E. A., Njua-Yafi, C., et al. (2019). Coverage and usage of insecticide treated nets (ITNs) within households: Associated factors and effect on the prevalence of malaria parasitemia in the Mount Cameroon area. *BMC Public Health*, 19, 1–11. <https://doi.org/10.1186/s12889-019-7555-x>
- Pava, Z., Burdam, F. H., Handayani, I., Trianty, L., Utami, R. A., Tirta, Y. K., et al. (2016). Submicroscopic and asymptomatic plasmodium parasitaemia associated with significant risk of anaemia in Papua, Indonesia. *PLoS One*, 11, 1–17.
- Richard, A., Richardson, S., & Maccario, J. (1993). A three-state Markov model of Plasmodium falciparum parasitemia. *Mathematical Biosciences*, 117, 283–300.
- Riley, C., Dellicour, S., Ouma, P., Kioko, U., Ter Kuile, F. O., Omar, A., et al. (2016). Knowledge and adherence to the national guidelines for malaria case management in pregnancy among healthcare providers and drug outlet dispensers in rural, western Kenya. *PLoS One*, 11, 1–18. <https://doi.org/10.1371/journal.pone.0145616>
- Rono, J., Färnert, A., Murungi, L., Ojal, J., Kamuyu, G., Guleid, F., et al. (2015). Multiple clinical episodes of Plasmodium falciparum malaria in a low transmission intensity setting: Exposure versus immunity. *BMC Medicine*, 13, 1–11.
- Sauboin, C. J., Van Bellinghen, L. A., Van De Velde, N., & Van Vlaenderen, I. (2015). Potential public health impact of RTS,S malaria candidate vaccine in sub-Saharan Africa: A modelling study. *Malaria Journal*, 14, 1–17.
- Sugiarto, S., Hadi, U. K., Soviana, S., & Hakim, L. (2017). Evaluation of long-lasting insecticidal nets on An. sudaicus (Diptera: Culicidae) in Sebatik Island, North Kalimantan. *Jurnal Vektor Penyakit*, 11, 61–70. <https://doi.org/10.22435/vektor.v11i2.7584.61-70>
- Sulistyawati, S., & Fitriani, I. (2019). Risk factor and cluster analysis to identify malaria hot spot for control strategy in Samigaluh Sub-District, Kulon Progo, Indonesia. *Iranian Journal of Public Health*, 48, 1647–1653.
- Taylor, A. R., Watson, J. A., Chu, C. S., Puaprasert, K., Duangpajama, J., Day, N. P., et al. (2019). Resolving the cause of recurrent Plasmodium vivax malaria probabilistically. *Nature Communications*, 10, 1–11.
- Wagman, J., Gogue, C., Tynuv, K., Mihigo, J., Bankineza, E., Bah, M., et al. (2018). An observational analysis of the impact of indoor residual spraying with non-pyrethroid insecticides on the incidence of malaria in Ségou region, Mali: 2012-2015. *Malaria Journal*, 17, 1–15. <https://doi.org/10.1186/s12936-017-2168-2>. URL:..
- Wagman, J. M., Varela, K., Zulliger, R., Saifodine, A., Muthoni, R., Magesa, S., et al. (2021). Reduced exposure to malaria vectors following indoor residual spraying of pirimiphos-methyl in a high-burden district of rural Mozambique with high ownership of long-lasting insecticidal nets: Entomological surveillance results from a cluster-randomized t. *Malaria Journal*, 20, 1–17. <https://doi.org/10.1186/s12936-021-03583-8>. URL:..

- West, P. A., Protopopoff, N., Wright, A., Kivaju, Z., Tiggererwa, R., Mosha, F. W., et al. (2015). Enhanced protection against malaria by indoor residual spraying in addition to insecticide treated nets: Is it dependent on transmission intensity or net usage? *PLoS One*, 10, 1–14. <https://doi.org/10.1371/journal.pone.0115661>
- White, N. J. (2011). Determinants of relapse periodicity in *Plasmodium vivax* malaria. *Malaria Journal*, 10.
- WHO. (2020). *World malaria report 2020*. Technical Report.
- WHO. (2021). Adolescent health in the South-East Asia Region. Retrieved January 16, 2020,. URL: <https://www.who.int/southeastasia/health-topics/adolescent-health>.