

Source and Sinks for the Calcium Released during Fertilization of Single Sea Urchin Eggs

ANDREW EISEN and GEORGE T. REYNOLDS

The Children's Hospital of Philadelphia, Philadelphia, Pennsylvania 19104; Department of Physics, Princeton University, Princeton, New Jersey 08544; and The Marine Biological Laboratory, Woods Hole, Massachusetts 02543

ABSTRACT The source and sinks for the intracellular calcium released during fertilization were examined in single eggs from the sea urchin, *Arbacia punctulata*. Single eggs were microinjected with the calcium photoprotein, aequorin. The calcium-aequorin luminescence was measured with a microscope-photomultiplier or observed with a microscope-image intensifier-video system. In the normal egg a propagated release has been observed.

The source of the calcium was investigated in the organelle-stratified centrifuged egg and by the use of mitochondrial uncouplers. In the organelle-stratified centrifuged egg, the calcium-aequorin luminescence was found to originate from the clear zone. The principal constituent of the clear zone is the endoplasmic reticulum.

Other potential sources of calcium are the mitochondria. Their contribution to the calcium transient was investigated by exposure of aequorin-injected eggs to mitochondrial uncouplers either before or after fertilization. There was no calcium released from the mitochondria before fertilization. A very large calcium store was released from the mitochondria after fertilization.

Interestingly, eggs fertilized in the presence of uncouplers showed no increase in the calcium-aequorin luminescence over untreated eggs. Apparently, in the absence of mitochondrial uptake, other sinks for calcium with affinity and capacity similar to the mitochondria exist, but their nature is unknown.

We suggest that the endoplasmic reticulum is the source of the intracellular calcium released upon fertilization and that the mitochondria are the principal sink. The results are discussed with regard to the metabolic activation of the egg.

A transient increase in cytoplasmic free calcium occurs during fertilization in sea urchin and other eggs (12, 13, 15, 20, 28, 43, 48). The increase in free calcium is thought to be essential for structural and metabolic changes attendant upon fertilization (18, 21, 22). We previously have shown that the free calcium increases to $\sim 1 \mu\text{M}$ at ~ 23 s after the onset of the fertilization potential in the egg from the sea urchin, *Arbacia punctulata*. The increase in cytoplasmic free calcium originates at the point of insemination and rapidly expands across the egg within 6–9 s (13, 15). In these studies we have used the calcium-specific photoprotein, aequorin, as an indicator of cytoplasmic free calcium. The calcium-aequorin luminescence was measured with a microscope-photomultiplier or spatially resolved with a microscope-image intensifier-video system.

We have investigated the sources of and sinks for the intracellular calcium released during fertilization of single eggs of the sea urchin, *A. punctulata*. The egg from this species of sea urchin is remarkable in that, when centrifuged, the organelles will stratify within the living, fertilizable egg according to their specific gravity (1, 22). From centripetal to centrifugal poles the strata as seen in the light microscope include the lipid cap, clear zone, granular zone, and pigment granules. The cortex remains undisplaced. Ultrastructural studies have better defined the constituents of each stratum (1). Although there is imperfect separation of the organelles, the centrifuged egg provides a way to examine the subcellular source of and sink for the released calcium under physiologic conditions in a single, living egg. If aequorin is used as the indicator of free calcium, then the luminescence will be observed originating

from the stratum containing the source.

The source of released calcium and the sink that buffers the cytoplasmic free calcium concentration in the sea urchin egg and other stimulus-responsive cells are of widespread interest. Much recent work has focused on two cellular components that are thought to regulate cytoplasmic free calcium: endoplasmic reticulum and mitochondria (4, 5, 26, 38, 42). In the centrifuged egg, the endoplasmic reticulum is the principal constituent of the clear zone (1). The mitochondria are scattered throughout the egg with an increased density in the lipid cap and between the clear and granular zones (1, 12, 22).

In this study we report direct observations of the calcium-aequorin luminescence during fertilization of single, aequorin-injected, centrifugally stratified *A. punctulata* eggs. We find that the luminescence originates principally from the clear zone. This suggests that the endoplasmic reticulum is the source of the released calcium. A mitochondrial contribution to the released calcium has been excluded by the discovery that no calcium can be released with uncoupling agents prior to fertilization. On the other hand, a very large store of calcium can be released from the mitochondria after fertilization. This indicates that the mitochondria are quite effective in buffering the cytoplasmic free calcium. Additional studies suggest that other sinks exist which are capable of significant calcium buffering.

MATERIALS AND METHODS

Gametes were obtained from *Arbacia punctulata* by electrical stimulation or intracoelomic injection of 0.5 M KCl (9). Eggs were washed twice in artificial or filtered natural sea water. Eggs were immobilized, compressed and slightly flattened, between parallel coverslips in a chamber designed for microinjection (27). Freshly diluted sperm were added to the chamber in the dark through a micropipette positioned near the egg. Sperm have access to the egg in a restricted equatorial distribution. Solutions of mitochondrial uncouplers in sea water (~1 μ M carbonyl cyanide-*p*-trifluoromethoxy phenylhydrazone [FCCP]¹ and 5 mM 2,4-dinitrophenol) were similarly added through micropipettes positioned near the egg. Experiments were conducted at room temperature (18–20°C).

Eggs were organelle-stratified by placing 0.5 ml of a suspension of washed eggs in sea water atop a 0.5-ml cushion of 1 M sucrose in an Eppendorf centrifuge tube. This was then centrifuged in either an Eppendorf microfuge or an inexpensive kitchen blender modified to operate as a centrifuge under the same conditions. Centrifuge times varied with the batch of eggs from 1–3 min. The stratified eggs were removed from the sea water–sucrose cushion interface and loaded into the injection chamber which was then filled with sea water. With care it is possible to microinject the stratified eggs without disrupting the stratification (12).

Aequorin or acetylated aequorin, a sensitive and specific calcium photoprotein (6, 39, 40), was pressure-injected into a single 75- μ m-diam *A. punctulata* egg (either normal or stratified) for each experiment; about 14 μ l of the aequorin solution was injected (10 mg/ml in 50 mM HEPES, 0.2 mM EGTA, pH 6.9–7.0). It was found that HEPES buffer was tolerated better on injection into the cells than others that were tried (12). The inclusion of EGTA in the injection buffer protected the aequorin from accidental contamination and led to light signals higher than those from chelator-free preparations (12). The acetylated aequorin was used in later studies. It produces a greater luminescence than the native protein (40). The final concentration of aequorin in the injected *A. punctulata* egg was ~13 μ M. The aequorin distribution in the microinjected eggs was assumed to approximate the distribution of fluorescein isothiocyanate-labeled albumin which was shown to distribute in the aqueous cytoplasm (12).

For the detection of the calcium-aequorin luminescence, light collected by an "objective" (Nikon 24 \times , 1.15 NA condenser; Zeiss 25 \times , 0.8 NA; Zeiss 25 \times , 0.6 NA, Leitz 50 \times , 1.0 NA) was directed to either a photomultiplier or an image intensifier. An EMI 6256 photomultiplier was operated at ~1100 V and had a dark current of ~10 pA. The output was amplified with a Kiethley electrometer, and the current was recorded on a Gould chart recorder (Gould Inc., Rolling Meadows, IL). The output of the EMI four-stage, magnetically

¹ Abbreviation used in this paper: FCCP, carbonyl cyanide-*p*-trifluoromethoxy phenylhydrazone.

focused image intensifier (9912) was photographically integrated for various periods on Polaroid 3000 ASA film during the initial studies with the native aequorin. In later studies with both the native and acetylated aequorin, the image intensifier output was observed in real time with a Dage silicon-intensified target vidicon (Dage-MTI Inc., Wabash, MI) and recorded on videotape. The video record was photographically integrated for various periods from the video monitor on Plus-X film. The microscopic system also included a Zeiss epifluorescence attachment for examination of the pyridine nucleotide fluorescence (8, 16, 17). Excitation is at 365 nm with fluorescence at 450 nm. Fig. 1 presents a schematic of the experimental system which is described in detail elsewhere (35–37).

Photographs of the eggs before and after fertilization were taken by conventional photomicrography. Analysis of both the temporal and spatial dynamics of the calcium transient was accomplished by photographing the video monitor during video playback for successive 1-s intervals with ~1/4 s between exposures for automatic advancement of the film. The photographs could be subsequently analyzed by densitometry.

RESULTS

The calcium transient that occurs following fertilization of the *Arbacia punctulata* egg has been described in detail (12, 13, 15). In brief, the cytoplasmic free calcium begins to increase at the point of insemination, and the region of increased free calcium rapidly expands across the egg in 6–10 s. The onset of the calcium transient occurs ~23 s after the fertilization potential (13). The free calcium concentration increases from <0.1 μ M to ~1 μ M as the expansion occurs. The free calcium remains at its peak value for 15–60 s and then decays to its previous level over several minutes (12, 14, 15).

In these experiments, we planned to observe the location of the calcium-aequorin luminescence in single, centrifugally stratified *A. punctulata* eggs. Of concern was the possibility that centrifugation, which would concentrate the source(s) of the calcium that is released, would alter the nature of the calcium transient. It does not do so. This can be seen in the photomultiplier traces in Fig. 2. In Fig. 2A the transient from a single, normal, aequorin-injected egg is seen. Fig. 2B shows the transient from a single, stratified, aequorin-injected egg. Both transients are of similar magnitude and duration. The cytoplasmic free calcium concentration increases from <0.1 μ M to ~1 μ M (13). Both normal and stratified eggs show similar egg-to-egg variation in the shape of the calcium transient. (Compare, for example, Fig. 2A and Fig. 4B.)

Also of concern was the possibility that the different strata

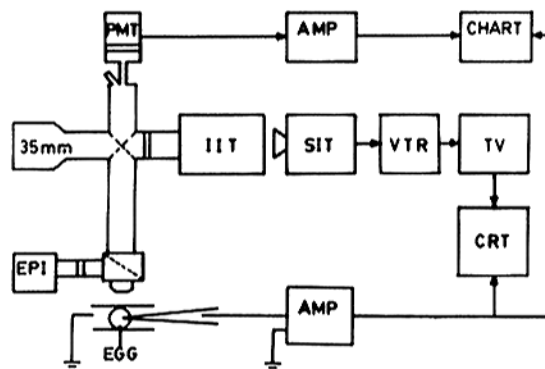

FIGURE 1 System schematic. The experimental system consists of a microscope with a DC-regulated Hg arc epifluorescence attachment, low-noise/high-gain photomultiplier tube (PMT), and image intensifier tube (IIT), silicon-intensified target vidicon (SIT), and with various amplifiers and recording devices to obtain temporal and spatial records of the fluorescent or luminescent changes occurring within a single egg.

would have markedly different transmission properties for the calcium-aequorin luminescence. When measured, the transmission of 460 nm (blue) light through an entire normal and stratified egg is 28 and 38%, respectively (data not shown). The overall difference is small and can probably be attributed to the displacement of the pigment granules in the stratified egg. Given that the overall transmission properties and the luminescence signals from the normal and the stratified egg

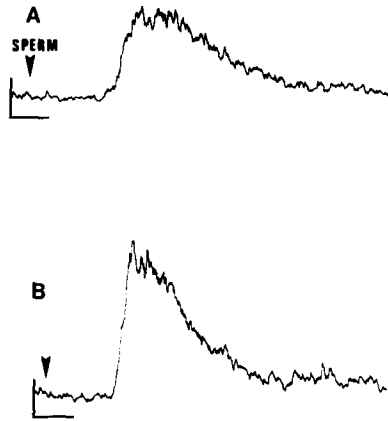

FIGURE 2 Calcium transients. The two photomultiplier traces record the calcium-aequorin luminescence upon fertilization with sperm from a single, normal *Arbacia punctulata* egg (A) and from a single, centrifugally stratified *A. punctulata* egg (B). The vertical bar is 20 pA and the horizontal bar is 25 s.

are comparable, the luminescence distribution in the stratified egg is likely to represent the distribution of the source of the calcium released during fertilization.

The distribution of the calcium-aequorin luminescence can be determined in the stratified egg by using the microscope-image intensifier-video system. Fig. 3 shows this distribution: the four panels record sequential 1-s photographs taken of the video monitor during playback of the real-time video record of the calcium transient. The single, centrifugally stratified *A. punctulata* egg had been injected in this case with the high-luminescence acetyl-aequorin. Each spot in the figure is the consequence of a single photon generated by the calcium-aequorin luminescence reaction. Despite the photon-limited nature of the calcium-aequorin luminescence from a single egg, the distribution is quite clear.

Rather quickly the entire egg seems to be luminescent as seen in the final photograph of panel Fig. 3a. This is similar to the normal, unstratified egg. However, unlike the normal egg in which the luminescence ultimately is uniform, the luminescence in the stratified egg has a non-uniform distribution. The luminescence signal grows principally within the clear zone to the point of saturating these 1-s photographic exposures. The distribution within the clear zone is apparent in panels Fig. 3, b-d when compared with the bright-field photomicrograph of the egg following fertilization (Fig. 3e).

When the individual photographs of the luminescence distribution in Fig. 3 or from the records of the calcium transient in other stratified eggs are processed using a densitometer, the

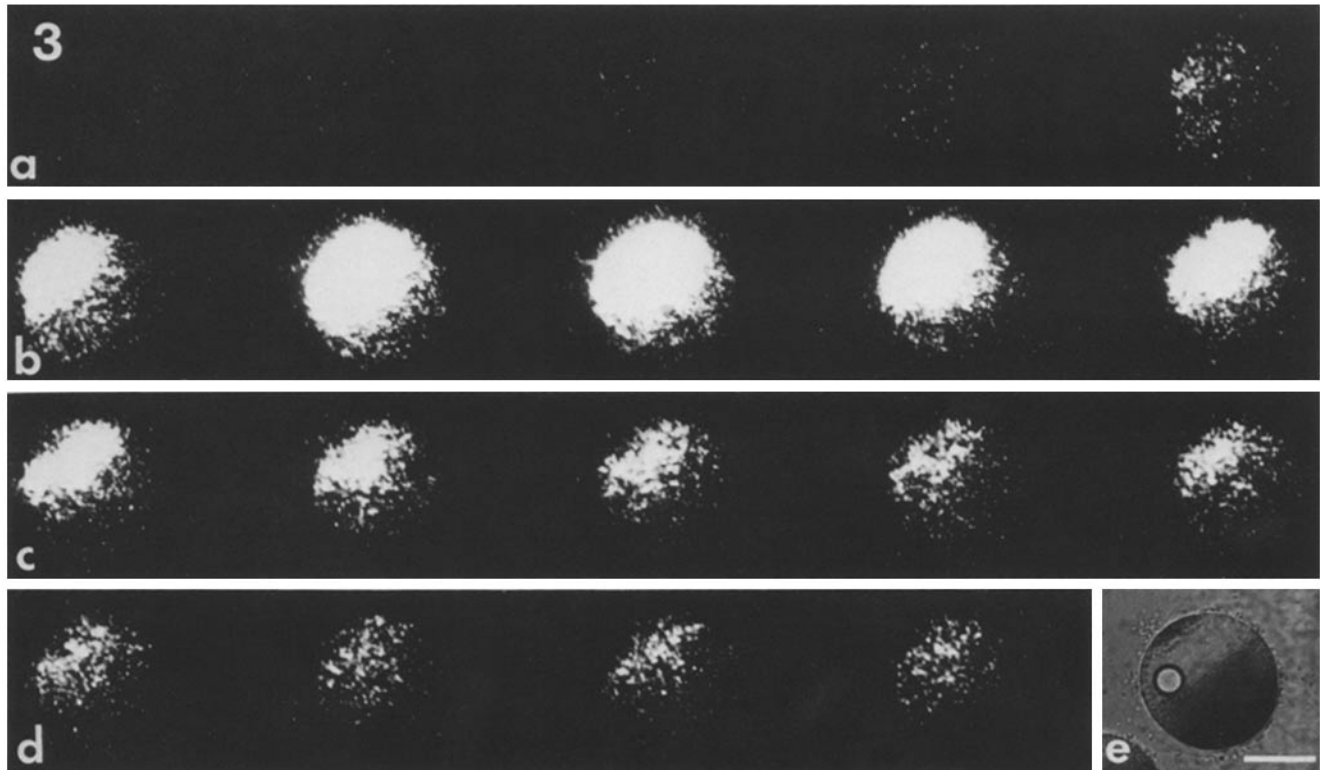

FIGURE 3 Luminescence distribution. A single, centrifugally stratified *Arbacia punctulata* egg was injected with the high-luminescence acetyl aequorin. The luminescence was observed with the microscope-image intensifier-SIT video system in real time and recorded on videotape. a-d present successive photographic integrations of 1 s each taken from the video monitor of the calcium-aequorin luminescence during playback of the real-time record. Rather quickly, luminescence is detected over the whole egg as seen in the final photograph of a. However, as the luminescence increases it does so with an asymmetric distribution, becoming most intense over the clear zone when compared with the bright-field photomicrograph of the egg after fertilization (e). The bright sphere within the clear zone is an oil droplet which accompanies the aequorin microinjection. Bar, 50 μm . $\times 190$.

distribution is better defined. The analysis was accomplished with the digital video densitometer developed by Dr. J. C. Haselgrove (University of Pennsylvania). The distribution as defined by such an analysis of Fig. 3 shows the luminescence to originate principally from the clear zone. However, as the luminescence is decaying the distribution shifts slightly to the interface between the clear and the granular zones (not shown).

The data suggest that the source of the calcium released at fertilization is found in the clear zone. The principal constituent of the heterogeneous clear zone, as defined by ultrastructural studies, is the endoplasmic reticulum (1). The slight shift in the luminescence distribution to the interface between the clear and granular zones suggests either that there is a small contribution from a second source or that the distribution is shifting to the location of the principal sink for the calcium.

There is an increased concentration of mitochondria, which are found in all strata, at the interface between the clear and the granular zones (1, 12). The mitochondria could also be either a source or sink for the calcium released at fertilization. These possibilities were examined with the use of the mitochondrial uncoupling agents 2,4-dinitrophenol and FCCP which will release mitochondrial calcium stores (2, 19, 33).

When either 2,4-dinitrophenol or FCCP is applied to the unfertilized, aequorin-injected *A. punctulata* egg, there is no demonstrable change in the cytoplasmic free calcium concentration as detected by calcium-aequorin luminescence. This can be seen in Fig. 4A which is the photomultiplier record from an aequorin-injected egg exposed to FCCP. If, however, an aequorin-injected egg is first fertilized and then exposed to an uncoupler, a very large store of calcium can be released from the mitochondria. This can be seen in Fig. 4, B and C. In Fig. 4B an aequorin-injected egg is fertilized with sperm and a fairly typical calcium transient is recorded. Subsequent to fertilization this same egg was exposed to FCCP, and an enormous luminescence signal resulted from the reaction of the cytoplasmic aequorin with the released calcium (Fig. 4C). These observations suggest that there is no releasable calcium

in the mitochondria before fertilization but that the mitochondria are very effective in buffering the cytoplasmic free calcium once it becomes elevated. To this end one would expect to find a very large calcium transient upon fertilization of the egg in which mitochondrial uptake is prevented. The prevention of mitochondrial calcium uptake can be accomplished with either exposure to an uncoupler or by the injection of ruthenium red. When these experiments are performed, the results are quite surprising.

Instead of a large luminescence signal, a rather typical calcium transient results when eggs exposed to an uncoupler are fertilized. This can be seen in Fig. 4D. Here the same egg that was exposed to FCCP in Fig. 4A was fertilized with sperm. The calcium-aequorin luminescence is not significantly different from that of the normal egg. In addition, a normal fertilization membrane formed. Likewise, eggs injected with ~14 pl of a 30 μ M ruthenium red solution (final intracellular concentration of ~1 μ M) do not demonstrate a calcium transient different from the normal egg (not shown). This suggests that a nonmitochondrial sink can sequester significant amounts of calcium in the absence of mitochondrial uptake.

It can be shown that the uncouplers enter the egg. If an uncoupler enters the egg it should abolish the pyridine nucleotide fluorescence (8). Uncouplers do so in both the unfertilized and the fertilized sea urchin egg (12). Within seconds after exposure to the uncoupler the pyridine nucleotide fluorescence is abolished. This demonstrates that uncouplers enter the egg, exert their physiologic effect, and should therefore release mitochondrial calcium. As uncouplers that enter the egg cannot release calcium from the mitochondria before fertilization but can do so after fertilization, we conclude that there is no releasable calcium in the mitochondria before fertilization and that the mitochondria become loaded with releasable calcium during fertilization.

This implies that the luminescence distribution at fertilization, which peaks over the clear zone (endoplasmic reticulum), should shift after fertilization after exposure to an uncoupler to a mitochondria-type distribution. That is, it should peak over the interface between the clear and granular zones, with the bulk of the luminescence originating from the granular zone. This can be seen in the luminescence distribution from a single egg that is fertilized and then exposed to FCCP, which is shown in Fig. 5. A video-densitometric analysis of the luminescence distribution of Fig. 5, a and b is shown in Fig. 6.

DISCUSSION

These studies were undertaken to discover the intracellular source of the calcium that is released upon fertilization. Evidence from various cell types indicates that there are two principal organelles that regulate the cytoplasmic free calcium concentration: the endoplasmic reticulum and the mitochondria (4, 5, 26, 38, 42). The evidence comes from several types of studies which include permeabilization of the cell membrane and exposure to releasing agents; cell fractionation; and ultrastructural staining (5, 7, 25, 26, 34, 38, 46, 47). Each of these methods has its advantages and disadvantages. The major disadvantages are that they require significant disruption of cell membranes and the replacement of the normal extracellular environment; complete disruption of the cell and the normal relationships among the organelles; and fixation and mixing artifacts.

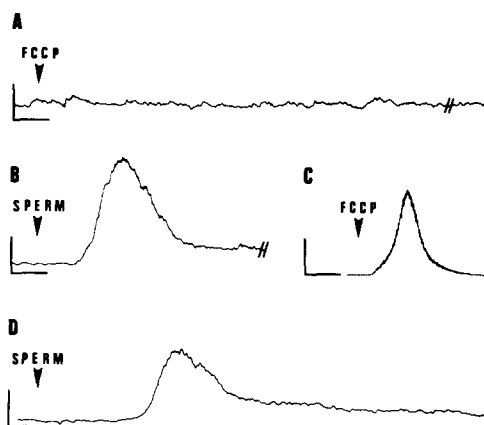

FIGURE 4 Response to uncouplers. The traces record the luminescence from single, aequorin-injected *Arbacia punctulata* eggs in response to sperm or FCCP. In A an egg is exposed to FCCP without any luminescence being detected. In B an egg is fertilized and a typical calcium transient results. In C the egg fertilized in B is then exposed to FCCP and a large luminescence response, ~50 times as bright as fertilization, is recorded. In D the egg exposed to FCCP in A is then fertilized and a typical, not larger than usual, calcium transient results. Each horizontal bar is 25 s. The vertical bars are 0.02, 0.05, 5.0, and 0.05 nA in A–D, respectively.

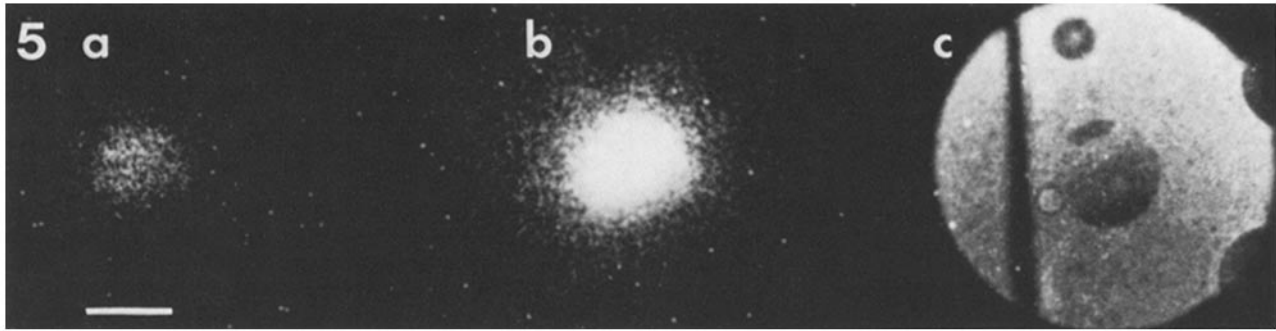
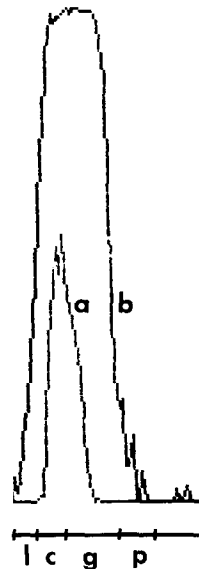

FIGURE 5 Luminescence distribution. The figure shows a single, centrifugally stratified *Arbacia punctulata* egg injected with native aequorin and seen through the image intensifier-photographic camera system. Image *a* is a 60-s integration of the luminescence from the calcium transient at fertilization. Image *b* is a 60-s integration of the luminescence from the fertilized egg after exposure to FCCP. Image *c* shows the orientation of the egg afterward viewed with dim background illumination. The luminescence distribution peaks over the clear zone in *a* and over the granular zone in *b*; see Fig. 6. Bar, 50 μm . $\times 222$.

FIGURE 6 Densitometry. The luminescence distributions across the images of the stratified egg in Fig. 5 are presented here. Densitometer traces *a* and *b* were obtained from images *a* and *b* of Fig. 5, respectively. The densitometer measures the density of the photograph in a narrow band which crosses the middle of the stratified egg from the centripetal pole to the centrifugal pole. The luminescence is displayed on an arbitrary scale along the vertical axis. The position in the photograph is displayed on the horizontal axis. The path traverses the lipid cap (*l*), clear zone (*c*), granular zone (*g*), and pigment granules (*p*), in that order. The luminescence distribution during fertilization (*a*) peaks over the clear zone. The peak shifts toward the centrifugal pole of the egg after the application of FCCP (*b*) once fertilization has occurred.



In this study we hoped to avoid these problems by examining the subcellular distribution of the calcium transient in intact, single eggs. The subcellular separation of the organelles was accomplished by centrifugation of the whole, living egg. While the separation of the organelles in the centrifuged egg does not approach the purity of cell fractionation, it is far more physiologic. These centrifugally stratified eggs will fertilize, elevate fertilization membranes, and develop normally (22). Furthermore, the separation is sufficient to draw conclusions about the subcellular source of the calcium that is released upon fertilization. Microinjection of aequorin is the only disruptive technique used in this study. Although microinjection has been associated with some cellular damage (32), it is possible, with careful technique, to prevent damage that has any demonstrable effect on development. Apart from injection techniques, it has been our experience that aequorin has deleterious effects on later stages of development but leaves the early stages of development unaffected (12).

We have demonstrated that the calcium released upon fertilization in the single, centrifugally stratified *Arbacia punctulata* egg is localized principally in the clear zone. As the major constituent of the clear zone is the endoplasmic reticulum, it would seem that the endoplasmic reticulum is the source of the calcium. This is consistent with evidence that a vesicular calcium buffering system exists in whole sea urchin eggs (27), in the isolated mitotic apparatus from sea urchin

eggs (41), and in purified microsomes from sea urchin eggs (25). Furthermore, it has been demonstrated that a physiological change in the microsomes occurs after fertilization (25).

The change that occurs in the isolated microsomes from the sea urchin egg may be the consequence of earlier biochemical changes that occur upon fertilization. One such change which has been described recently is an increase in the level of polyphosphoinositides (45). Elevated levels of inositol triphosphate are known to release calcium from the endoplasmic reticulum (3, 30, 31, 34, 44) and this appears to occur before the onset of the calcium transient in the sea urchin egg.

After the calcium is released from the endoplasmic reticulum it is avidly taken up principally by the mitochondria such that the cytoplasmic free calcium concentration does not go above 1 μM . This was demonstrated by releasing the mitochondrial calcium with uncouplers before and after fertilization. To our surprise, there was no releasable calcium in the mitochondria before fertilization. There was a very large store of calcium that could be released from the mitochondria after fertilization, which often produced calcium-aequorin luminescence signals 100 times as great as did fertilization.

The influx of calcium into the mitochondria may represent an extreme example of a metabolic control system such as that proposed by Denton et al. (10) and Denton and McCormick (11, 29). They have postulated that cellular metabolism is regulated by several mitochondrial dehydrogenases. The dehydrogenases are quite sensitive to the level of mitochondrial free calcium which, in turn, is a reflection of the cytoplasmic free calcium concentration. The cytoplasmic free calcium is regulated by other calcium buffering systems such as the endoplasmic reticulum. Indeed the unfertilized sea urchin egg is a metabolically quiescent cell which is "turned on" at fertilization (16-18, 23). This could be accomplished by the influx of calcium into the calcium-deficient mitochondria. In addition to the physiologic evidence presented here for the influx of calcium into the mitochondria of the sea urchin egg, there is also morphologic and physiologic evidence from other studies that such occurs during fertilization (24).

We postulate that the mitochondria are the principal sink for the calcium which is released at fertilization. To this end we were surprised to find that the calcium-aequorin luminescence signal after fertilization, in the presence of uncouplers or after prior injection of ruthenium red, is no different from the signal in their absence. This might be explained by the results of a study on the microsomes isolated from sea urchin eggs. This study reported a fivefold greater uptake of calcium

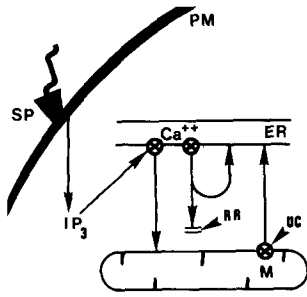

FIGURE 7 Calcium fluxes. This figure summarizes our findings and speculations about the calcium fluxes at fertilization in single sea urchin eggs. Sperm (SP) initiates a rise in the cytosolic inositol triphosphate (IP_3) through changes mediated at the egg plasma membrane (PM). The IP_3 , in turn, promotes the release of Ca^{++} from the endoplasmic reticulum (ER). The principal flux is from the endoplasmic reticulum to the calcium-deficient mitochondria (M). When mitochondrial calcium uptake is blocked by ruthenium red (RR) or when calcium is released by uncouplers (UC) the calcium is sequestered by the endoplasmic reticulum.

after fertilization (25). Perhaps this is a consequence of the changes conferred upon the microsomes by inositol triphosphate. These findings and speculations are presented in schematic form in Fig. 7.

We have identified the endoplasmic reticulum as the likely source of the calcium released at fertilization. There is circumstantial evidence to suggest that this is mediated by an increase in the level of inositol triphosphate. This remains to be proven in the sea urchin egg.² We also have suggested that the flux is principally into the mitochondria. In this fashion the metabolically quiescent egg is activated to begin development. The sea urchin egg mitochondria would therefore seem ideal for the study of metabolic control systems. Indeed our own studies of the pyridine nucleotide metabolism in the centrifugally stratified egg implicate the mitochondria as prime participants in the activation of the metabolism at fertilization (13). These studies will be described at a later date.

We thank Dr. O. Shimomura for his gifts of aequorin and acetyl aequorin; Drs. A. Gelperin, J. C. Haselgrove, S. Inoué, L. A. Jaffe, S. K. Joseph, J. S. Leigh, Jr., and A. Walton for lively discussions; Drs. G. W. Ellis, A. Gelperin, J. C. Haselgrove, and A. Walton for the loan of laboratory equipment; Dr. S. Douglas for the use of his photographic dark room; and Dr. Wm. Schwartz for the use of his word processor.

This work was supported by Department of Energy grant DE-AC02-76LCV03120 (to G. T. Reynolds).

Received for publication 11 October 1984, and in revised form 2 January 1985.

REFERENCES

- Anderson, E. 1970. A cytological study of the centrifuged whole, half, and quarter eggs of the sea urchin, *Arbacia punctulata*. *J. Cell Biol.* 47:711-733.
- Beatrice, M. C., J. W. Palmer, and D. R. Pfeiffer. 1980. The relationship between mitochondrial membrane potential, permeability and the retention of calcium by mitochondria. *J. Biol. Chem.* 255:8863-8871.
- Beaven, M. A., J. P. Moore, G. A. Smith, T. R. Hesketh, and J. C. Metcalf. 1984. The calcium signal and phosphatidylinositol breakdown in 2H3 cells. *J. Biol. Chem.* 259:7137-7142.
- Becker, G. L., G. Fiskum, and A. L. Lehninger. 1980. Regulation of free Ca^{++} by liver mitochondria and endoplasmic reticulum. *J. Biol. Chem.* 255:9009-9012.
- Burgess, G. M., J. S. McKinney, A. Fabiato, B. A. Leslie, and J. W. Putney, Jr. 1983. Calcium pools in saponin permeabilized guinea pig hepatocytes. *J. Biol. Chem.* 258:15337-15345.
- Blinks, J. R., F. G. Prendergast, and D. G. Allen. 1976. Photoproteins as biological calcium indicators. *Pharmacol. Rev.* 28:1-93.
- Cardasis, C. A., H. Schuel, and L. Herman. 1978. Ultrastructural localization of calcium in unfertilized sea urchin eggs. *J. Cell Sci.* 31:101-115.
- Chance, B., and B. Thorell. 1959. Localization and kinetics of reduced pyridine nucleotides in living cells by microfluorimetry. *J. Biol. Chem.* 234:3044-3050.
- Costello, D. P., and C. Henley. 1971. Methods for Obtaining and Handling Marine Eggs and Embryos. Marine Biological Laboratory, Woods Hole, MA. Second ed. 247 pp.
- Denton, R. M., J. G. McCormick, and N. J. Edgell. 1980. Role of calcium ions in the regulation of intramitochondrial metabolism. *Biochem. J.* 190:107-117.
- Denton, R. M., and McCormick, J. G. 1980. On the role of the calcium transport cycle in heart and other mammalian mitochondria. *FEBS (Fed. Eur. Biochem. Soc.) Lett.* 119:1-18.
- Eisen, A. 1982. Local intracellular metabolism at fertilization in single marine eggs. Ph.D. thesis. University of Pennsylvania, Philadelphia, PA. 169 pp.
- Eisen, A., D. P. Kiehart, S. J. Wieland, and G. T. Reynolds. 1984. The temporal sequence and spatial distribution of early events of fertilization in single sea urchin eggs. *J. Cell Biol.* 99:1647-1654.
- Eisen, A., and G. T. Reynolds. 1981. Source and behavior of the pyridine nucleotide fluorescence change in single, marine, invertebrate eggs. *Biol. Bull. (Woods Hole)*. 161:355a. (Abstr.)
- Eisen, A., G. T. Reynolds, S. J. Wieland, and D. P. Kiehart. 1983. Calcium transients during fertilization in single sea urchin eggs. *Biol. Bull. (Woods Hole)*. 165:514a. (Abstr.)
- Epel, D. 1964. A primary metabolic change at fertilization: interconversion of pyridine nucleotides. *Biochem. Biophys. Res. Commun.* 17:62-68.
- Epel, D. 1964. Simultaneous measurement of TPNH formation and respiration following fertilization of the sea urchin egg. *Biochem. Biophys. Res. Commun.* 17:69-73.
- Epel, D. 1978. Mechanisms of activation of sperm and egg during fertilization of sea urchin gametes. *Curr. Top. Dev. Biol.* 12:185-246.
- Fiskum, G., and A. L. Lehninger. 1980. The mechanisms and regulation of mitochondrial calcium transport. *Fed. Proc.* 39:2432-2436.
- Gilkey, J. C., L. F. Jaffe, E. B. Ridgway, and G. T. Reynolds. 1978. A free calcium wave traverses the activating egg of the Medaka, *Orizayas latipes*. *J. Cell Biol.* 76:448-466.
- Hagamuchi, Y., and Y. Hiramoto. 1981. Activation of sea urchin eggs by microinjection of calcium buffers. *Exp. Cell Res.* 134:171-179.
- Harvey, E. B. 1956. The American Arbacia and Other Sea Urchins. Princeton University Press, Princeton, NJ. 298 pp.
- Horwitz, B. A. 1965. Rates of oxygen consumption of fertilized and unfertilized *Asterias*, *Arbacia*, and *Spisula* eggs. *Exp. Cell Res.* 38:620-625.
- Innis, M. A., T. R. Beers, and S. P. Craig. 1976. Mitochondrial regulation in sea urchins. *Exp. Cell Res.* 98:47-56.
- Inoue, H., and T. Yoshioka. 1982. Comparison of Ca^{++} uptake characteristics of microsomal fractions isolated from unfertilized and fertilized sea urchin eggs. *Exp. Cell Res.* 140:283-288.
- Joseph, S. K., K. E. Coll, R. H. Cooper, J. S. Marks, and J. R. Williamson. 1983. Mechanisms underlying calcium homeostasis in isolated hepatocytes. *J. Biol. Chem.* 258:731-741.
- Kiehart, D. P. 1981. Studies on the *in vivo* sensitivity of spindle microtubules to calcium ions and evidence for a vesicular sequestering system. *J. Cell Biol.* 88:606-617.
- Kiehart, D. P., G. T. Reynolds, and A. Eisen. 1977. Calcium transients during early development in echinoderms and teleosts. *Biol. Bull. (Woods Hole)*. 153:335a. (Abstr.)
- McCormick, J. G., and R. M. Denton. 1980. Role of calcium in the regulation of intramitochondrial metabolism. *Biochem. J.* 190:95-105.
- Majerus, P. W., E. J. Neufeld, and D. B. Wilson. 1984. Production of phosphoinositide-derived messengers. *Cell.* 37:701-703.
- Michell, R. H., S. S. Jafferji, and L. M. Jones. 1977. The possible involvement of phosphatidylinositol breakdown in the mechanism of stimulus-response coupling at receptors which control cell surface calcium gates. *Adv. Exp. Med. Biol.* 83:447-464.
- Miller, D. S., Y. T. Lau, and S. B. Horowitz. 1984. Artifacts caused by cell microinjection. *Proc. Natl. Acad. Sci. USA.* 81:1426-30.
- Nicholls, D. 1981. Some recent advances in mitochondrial calcium transport. *Trends Biochem. Sci.* 36-38.
- Prentki, M., T. J. Biden, D. Janjic, R. F. Irvine, M. J. Berridge, and C. B. Wollheim. 1984. Rapid mobilization of Ca^{++} from rat insulinoma microsomes by inositol 1,4,5 triphosphate. *Nature (Lond.)*. 309:562-564.
- Reynolds, G. T. 1972. Image intensification applied to biological problems. *Q. Rev. Biophys.* 5:295-347.
- Reynolds, G. T. 1980. Applications of image intensification to low level fluorescence studies of living cells. *Microsc. Acta.* 83:55-62.
- Reynolds, G. T., and D. L. Taylor. 1980. Image intensification applied to light microscopy. *Bioscience.* 30:586-592.
- Ronning, S. A., G. A. Heatley, and T. F. J. Martin. 1982. Thyrotropin-releasing hormone mobilizes Ca^{++} from endoplasmic reticulum and mitochondria of GH3 pituitary cells: characterization of cellular Ca^{++} pools by a method based on digitonin permeabilization. *Proc. Natl. Acad. Sci. USA.* 79:6294-6298.
- Shimomura, O., F. H. Johnson, and Y. Saiga. 1962. Extraction, purification and properties of aequorin, a bioluminescent protein from the luminous hydromedusean, *Aequora*. *J. Cell. Comp. Physiol.* 59:223-239.
- Shimomura, O., and A. Shimomura. 1982. EDTA-binding and acylation of the calcium-sensitive photoprotein aequorin. *FEBS (Fed. Eur. Biochem. Soc.) Lett.* 138:201-204.
- Silver, R. B., R. D. Cole, and W. Z. Cande. 1980. Isolation of mitotic apparatus containing vesicles with calcium sequestration activity. *Cell.* 19:505-516.
- Somlyo, A. P. 1984. Cellular site of calcium regulation. *Nature (Lond.)*. 309:516-517.
- Steinhardt, R. A., R. Zucker, and G. Schatten. 1977. Intracellular calcium release of fertilization in the sea urchin egg. *Dev. Biol.* 58:185-196.
- Streb, H., R. F. Irvine, M. J. Berridge, and I. Schultz. 1983. Release of Ca^{++} from a nonmitochondrial intracellular store in pancreatic acinar cells by inositol 1,4,5 triphosphate. *Nature (Lond.)*. 306:67-69.
- Turner, P. R., M. P. Sheetz, and L. A. Jaffe. 1984. Fertilization increases the polyphosphoinositol content of sea urchin eggs. *Nature (Lond.)*. 310:414-415.
- Walz, B. 1982. Ca^{++} sequestering smooth endoplasmic reticulum in an invertebrate photoreceptor. I. Intracellular topography as revealed by OsFeCN staining and in situ Ca accumulation. *J. Cell Biol.* 93:839-848.
- Walz, B. 1982. Ca^{++} sequestering smooth endoplasmic reticulum in an invertebrate photoreceptor. II. Its properties as revealed by microphotometric measurements. *J. Cell Biol.* 93:849-859.
- Zucker, R. S., R. A. Steinhardt, and M. M. Winkler. 1978. Intracellular calcium release and the mechanism of parthenogenetic activation of the sea urchin egg. *Dev. Biol.* 65:285-295.

² After this manuscript was accepted for publication, M. Whitaker and R. F. Irvine reported that inositol 1,4,5-triphosphate microinjection activates sea urchin eggs (1985, *Nature [Lond.]*, 312:636-639).