



OPEN

SUBJECT AREAS:

QUANTUM
INFORMATION

QUANTUM PHYSICS

Extreme violation of local realism with a hyper-entangled four-photon-eight-qubit Greenberger-Horne-Zeilinger state

Huai-Xin Lu, Lian-Zhen Cao, Jia-Qiang Zhao, Ying-De Li & Xiao-Qin Wang

Department of Physics and Electronic Science, Weifang University, Weifang, Shandong 261061, China.

Received
24 December 2013Accepted
11 March 2014Published
26 March 2014Correspondence and
requests for materials
should be addressed to
H.-X.L. (luhuaixin@wfu.
edu.cn)

The highest qubit Ardehali inequality violation with 203 standard deviations is first experimentally demonstrated using the hyper-entangled four-photon-eight-qubit Greenberger-Horne-Zeilinger (GHZ) state. Moreover, we experimentally investigate the robustness of the Ardehali inequality for the four-, six-, and eight-qubit GHZ states in a rotary noisy environment systematically. Our results first validate the Ardehali' theoretical statement of relation between violation of Ardehali inequality and particle number, and proved that Ardehali inequality is more robust against noise in larger number qubit GHZ states, and provided an experimental benchmark for us to estimate the safety of quantum channel in the noisy environment.

Nonlocality is one of the most surprising and important features of quantum physics. It is firstly referred by Einstein, Podolsky and Rosen (EPR), and has been receiving an enormous attention and interest of scientists since Bell designed an inequality to expose it. Bell-type inequalities against local realism (LR) model not only plays a crucial role in fundamental research, but is also at the basis of nearly all quantum information protocols applying process, such as proving the security of quantum cryptography, the reduction of communication complexity, the estimates for the dimension of the underlying Hilbert space, and the entangled games¹⁻⁴. For example, in Ekert's quantum key distribution (QKD) protocol⁵, one encrypts the key into the non-compatible qubit and the security of quantum cryptography is based on maximal violation of local realism, that is, the greater of the violation value means that the QKD scheme is more security. So, it is useful to know the largest violation of a given Bell inequality that quantum mechanics makes possible, and, in addition, which quantum state will produce this violation⁶.

What's even more exciting is Mermin and Ardehali showed that quantum mechanics (QM) can violate the multi-particle Bell-type inequalities imposed by LR by an amount that grows exponentially with particle number $n^{7,8}$, that is, going to higher entangled systems the conflict between QM and LR becomes ever stronger. Over the past years, great efforts have been devoted to generate and manipulate more qubits and get the larger violation between QM and LR. However, the effect of quantum mechanics violates the Bell inequalities by an amount that grows exponentially with the number of particles is difficult to observe in real experiments because the low multi-photon ($n > 4$) coincidence count rate and the higher double-pair emission noise effect⁹⁻¹². To the best of our knowledge, the highest qubit number experimentally used to demonstrate to the violation of the multi-particle Bell-type inequalities is only six by now¹³. Fortunately, one can encode quantum information not only in the polarization of a single photon, and in its spatial modes¹⁴, arrival time or orbital angular momentum as well¹⁵. Obviously, using the hyper-entangled technology, one can effectively achieve higher qubit entanglement states, which significantly reduces the decoherence problems and dramatically increases the efficiency of detecting EPR elements of reality¹⁶. So, hyperentangled photonic states have been experimentally realized^{17,18}, and shown to offer significant advantages in quantum super-dense coding¹⁹, efficient construction of cluster states^{20,21} and multiqubit logic gates²².

Moreover, the robustness of multi-bit hyper-entangled system with noise has almost no further research. As we all know, in realistic applications, pure entangled states become mixed states due to different types of noise, which will lead to the failure of the information processing^{23,24}. It is lucky that the violations of Bell inequalities provide a method to characterize the robustness of the entanglement against noise. Thus, the experimental investigations of the robustness of Bell's inequality of multi-particle hyperentanglement states have important physical significance and application value.

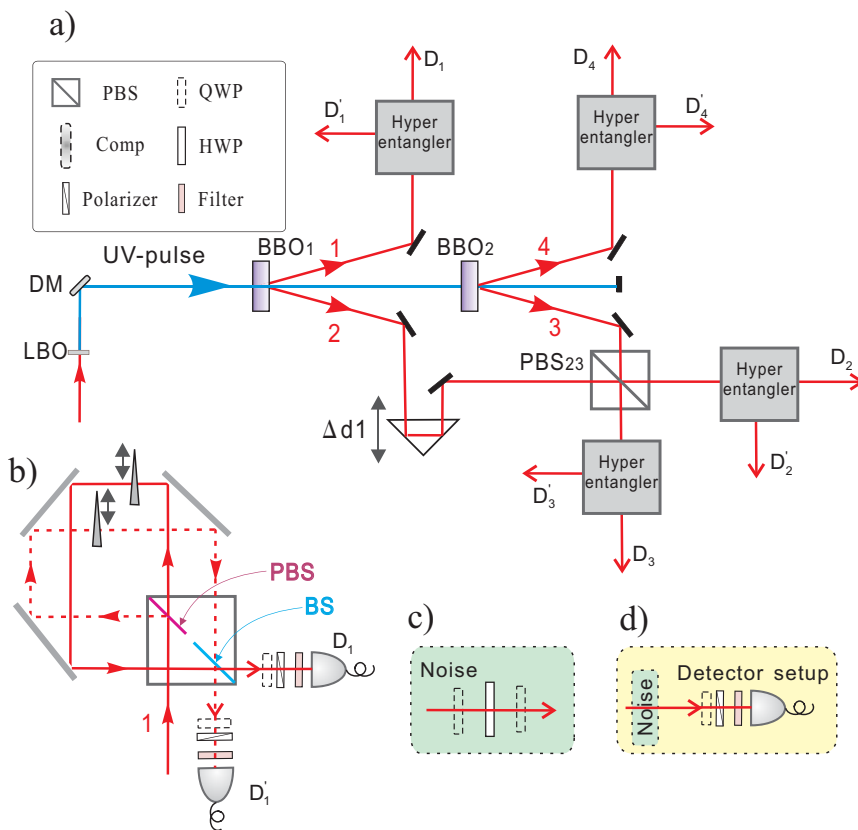

Figure 1 | (a), Schematic drawing of the experimental set-up for the generation of hyper-entangled eight-qubit GHZ states. (b), The experimentally stable interferometer with a Sagnac-like configuration. The specially designed beam splitter cube (PNBS) is half-PBS coated and half-NBS coated. High-precision small-angle prisms are inserted for fine adjustments of the relative delay of the two different paths. (c). The setup for engineering rotary noise. Noisy quantum channels are engineered by one HWP sandwiched by two QWPs. (d). The detector setup.

In this work, using the hyper-entangled four-photon-eight-qubit GHZ states with a fidelity of $(79.6 \pm 0.5)\%$ exploited both the photons' polarization and spatial degrees of freedom, we demonstrated the highest qubit (eight qubits) Bell inequality violation with 203 standard deviations. Most importantly, we systematically experimentally investigated the robustness of the Bell-type inequality for the four, six, eight-qubit GHZ states in a rotary noisy environment, and first proved that the Ardehali inequality is more robust in larger number bits GHZ states.

Results

Theoretical model. Using the Bell' theorem, Mermin⁷ derived an n-particle Bell inequality, and Ardehali derived an optimized Bell inequality for an n-particle system in a GHZ state⁸. Consider an n-particle GHZ state $|\Phi_n\rangle = (|H \dots H_i \dots H_n\rangle + |V \dots V_i \dots V_n\rangle) / \sqrt{2}$, where H_i and V_i are horizontal and vertical polarization of i particle. According to the local realism assumption, the nonlocal character of the state $|\Phi_n\rangle$ can be characterized if defined the operator A as $A = A_1 + A_2$, with

$$A_1 = \left(\sigma_x^1 \sigma_x^2 \sigma_x^3 \dots \sigma_x^{(n-1)} - \sigma_y^1 \sigma_y^2 \sigma_x^3 \dots \sigma_x^{(n-1)} + \sigma_y^1 \sigma_y^2 \sigma_y^3 \sigma_x^4 \dots \sigma_x^{(n-1)} - \dots + \dots \right) (\sigma_a^n - \sigma_b^n), \tag{1}$$

and

$$A_2 = \left(-\sigma_y^1 \sigma_x^2 \dots \sigma_x^{(n-1)} + \sigma_y^1 \sigma_y^2 \sigma_y^3 \sigma_x^4 \dots \sigma_x^{(n-1)} - \sigma_y^1 \dots \sigma_y^5 \sigma_x^6 \dots \sigma_x^{(n-1)} + \dots - \dots \right) (\sigma_a^n + \sigma_b^n). \tag{2}$$

here σ_a and σ_b are defined as $\sigma_a = (\sigma_x + \sigma_y) / \sqrt{2}$, and $\sigma_b = (\sigma_x - \sigma_y) / \sqrt{2}$, respectively. Using the generalized Clauser-Horne-Shimony-Holt lemma²⁵, the upper bound of the function F can be got according to the assumption of LR

$$F \leq \begin{cases} 2^{n/2}, & n(\text{even}) \\ 2^{(n+1)/2}, & n(\text{odd}). \end{cases} \tag{3}$$

In comparison, the expected value of A standard rules of QM can be calculate as

$$\langle \Phi_n | A | \Phi_n \rangle = 2^{n-1/2}. \tag{4}$$

It can be seen that quantum theoretic value exceeds the limit imposed by the premises of EPR by an exponentially large amount of $2^{(n-2)/2}$ for n odd or $2^{(n-1)/2}$ for n even.

For eight qubits states, the Ardehali operator can be shown as

$$\mathcal{A} = \left(\sigma_x^1 \sigma_x^2 \sigma_x^3 \dots \sigma_x^7 - \sigma_y^1 \sigma_y^2 \sigma_x^3 \dots \sigma_x^7 + \dots - \dots \right) (\sigma_a^8 - \sigma_b^8) + \left(-\sigma_y^1 \sigma_x^2 \dots \sigma_x^7 + \sigma_y^1 \sigma_y^2 \sigma_y^3 \dots \sigma_x^7 - \dots + \dots \right) (\sigma_a^8 + \sigma_b^8). \tag{5}$$

Experiment model. Here we experimentally observed violation of Bell inequality in case of eight qubit GHZ state. The four-photon-eight-qubit hyperentangled state exhibit maximal both in polarization and spatial degrees of freedom, which can be shown as

$$|GHZ_8\rangle = \frac{1}{\sqrt{2}} (|HHHHH'H'H'H'\rangle + |VVVVVV'V'V'V'\rangle) \tag{6}$$

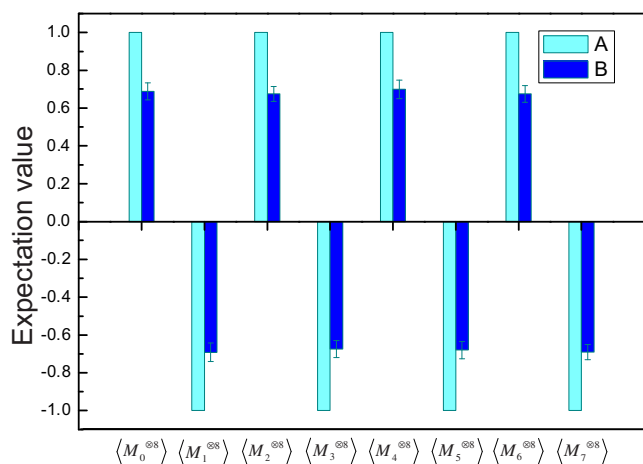

Figure 2 | Experimental results of expectation values of $M_k^{\otimes 8}$. The settings are measured in 30 minute. Error bars indicate one standard deviation deduced from propagated Poissonian counting statistics of the raw detection events. (A), the theoretical value. (B), the experimental value.

here H and V denote horizontal and vertical polarization and H' and V' label two orthogonal spatial modes of the photons.

The first step to create an eight qubit GHZ state is produce a four photon entangled GHZ state by combining two polarization entangled pairs into a polarization beam splitter (PBS) which produced from SPDC process in BBO. The experimental setup is shown in Fig. 1a and the operating steps are similar to Refs. 18, 26, 27. In which two pairs of entangled photons are produced by spontaneous parametric down-conversion²⁸ in the state $(|H_1H_2\rangle + |V_1V_2\rangle)/\sqrt{2}$ in paths 1-2 and $(|H_3H_4\rangle + |V_3V_4\rangle)/\sqrt{2}$ in paths 3-4, respectively. The photon 2 is combined with photon 3 on a polarizing beam splitter (PBS). When the polarization of the two photons is identical, the four-photon GHZ entanglement state $|GHZ\rangle_p^4 = (|H\rangle^{\otimes 4} + |V\rangle^{\otimes 4})/\sqrt{2}$ is prepared.

Then, four qubits in spatial modes are added to construct eight-qubit cat state. Consider a polarized single-photon qubit in the state $\alpha|H\rangle + \beta|V\rangle$ that passes through a PBS (see Fig. 1b). The PBS separates the photon into two possible spatial modes H' and V' , according to their polarization H and V , respectively. The state of this single photon can now be written as $\alpha|HH'\rangle + \beta|VV'\rangle$, an entangled state

between its polarization and spatial degree of freedom. Thereby, the hyper-entangled 8-qubit GHZ state (6) can be created.

A noisy quantum channels $R_x(\pm\theta)$ (see Experimental result section) is experimentally simulated by using one half-wave plate (HWP) sandwiched with two quarter-wave plates (QWPs)²⁹ (see Fig. 1(c)).

$$R_x(\pm\theta) = \begin{pmatrix} \cos 2\theta & \mp i \sin 2\theta \\ \mp i \sin 2\theta & \cos 2\theta \end{pmatrix} \quad (7)$$

The operation for qubit i with probability λ i.e. noisy intensity is given by³⁰, here λ is equivalent for every one of the qubits (The noise is only generated on the polarization qubits). The HWP is switched angles θ and the QWPs are set at 0° with respect to the vertical direction. In this way, the noisy quantum channel can be engineered with intensity $\lambda = \sin^2(2\theta)$. The measurement of polarization qubits is performed using HWPs, QWPs and Polarizers as shown in Fig. 1(d). We measure the spatial qubit by using an optical interferometer which combine the two pathes onto a non-polarizing beam splitter and controlling the relative phase with an adjustable delay between these two paths (see Fig. 1(b)).

Discussion

To verify that $|H\rangle^{\otimes 4}|H'\rangle^{\otimes 4}$ and $|V\rangle^{\otimes 4}|V'\rangle^{\otimes 4}$ are indeed in a coherent superposition, the measurement in the basis $|H\rangle \pm e^{i\theta}|V\rangle(|H'\rangle \pm e^{i\theta}|V'\rangle)$ is preformed, where $\theta = k\pi/8 (k = 0, 1 \dots 7)$. The expectation values of the observable $\langle M_k^{\otimes 8} \rangle = \langle (\cos\theta\sigma_x + \sin\theta\sigma_y)^{\otimes 8} \rangle$ are shown in Fig. 2. From the experimental result in Fig. 2, we can further calculate the fidelity of the 8-qubit cat state and confirm the presence of genuine multi-particle entanglement. For the 8-qubit GHZ state, the fidelity can be measured using the operator $\mathcal{B} = 1/2 [(|H\rangle|H'\rangle\langle H'|\langle H|)^{\otimes 4} + (|V\rangle|V'\rangle\langle V'|\langle V|)^{\otimes 4}] + 1/16 \sum_{k=0}^7 (-1)^k (M_k)^{\otimes 8}$. According to the data shown in Fig. 2, the fidelity observed for the state prepared in our experiment is $(79.6 \pm 0.5)\%$, which is greatly exceed the minimum bound of 50% ³¹. Thus, with high statistical significance, genuine n -qubit entanglement of the GHZ states created in our experiment is confirmed. Furthermore, we give the measurement results in the $|H\rangle/|V\rangle(|H')/|V'\rangle$ basis, as shown in Fig. 3 a, b, and c for $|\Phi\rangle^{\otimes 4}$, $|\Phi\rangle^{\otimes 6}$, and $|\Phi\rangle^{\otimes 8}$, which show that the signal-to-noise ratio (defined as the ratio of the desired components to that of the other non-desired ones) is about 11 : 1, 8.97 : 1, and 7.04 : 1 respectively.

In the following, let us analyze the QM predictions for the eight-qubit GHZ state (6). As the polarization states of a photon are a realization of a qubit, one can represent it as $|H\rangle$ and $|V\rangle$. That is,

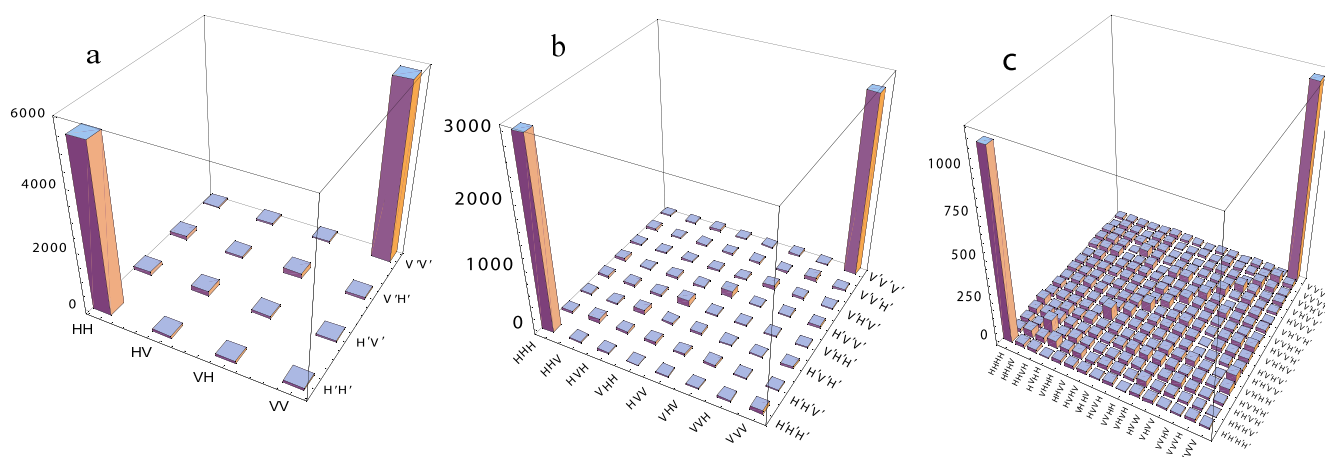

Figure 3 | Experimental results for determination of the four-, six-, and eight-qubit GHZ states. (a), (b), and (c), Coincidence counts obtained in the the $|H\rangle/|V\rangle$ basis ($|H'\rangle/|V'\rangle$) basis, accumulated for 600 s, 900 s, and 1800 s for four-(a), six- (b), and eight-qubit (c) state respectively.



Table 1 | Experimental values of the fidelity, the violation, the statistical error, and the standard deviations of states for different values of θ . λ , ν , \mathcal{E} , \mathcal{S} , and \mathcal{F} represent the values of rotary noise, violation, statistical error, standard deviation and fidelity correspondingly. Each setting $\sigma_x^1 \sigma_x^2 \dots \sigma_x^7 \sigma_y^8$ in the Bell inequality is measured for 1800 s, $\sigma_x^1 \sigma_x^2 \dots \sigma_x^5 \sigma_y^6$ for 900 s, and $\sigma_x^1 \sigma_x^2 \sigma_x^3 \sigma_y^4$ for 600 s, respectively. The average total count number for each inequality is about 4000 for eight-bits, 6500 for six-bits, and 12000 for four-bits. The error represent one standard deviation deduced from propagated Poissonian counting statistics of the raw detection events

θ	λ	4-qubit				6-qubit				8-qubit			
		F	ν	\mathcal{E}	\mathcal{S}	F	ν	\mathcal{E}	\mathcal{S}	F	ν	\mathcal{E}	\mathcal{S}
$\pm 0^\circ$	0	0.848	4.12	0.13	31.7	0.839	22.73	0.25	90.9	0.796	91.2	0.45	202.8
$\pm 2^\circ$	0.0049	0.841	3.84	0.14	27.4	0.762	15.71	0.24	62.8	0.735	69.9	0.42	166.5
$\pm 4^\circ$	0.0194	0.822	3.28	0.13	25.2	0.716	11.59	0.25	46.4	0.675	48.1	0.43	111.8
$\pm 6^\circ$	0.0432	0.787	2.51	0.13	19.3	0.663	6.75	0.23	29.3	0.644	36.3	0.43	84.4
$\pm 8^\circ$	0.0760	0.750	1.36	0.14	9.7	0.636	4.34	0.25	17.4	0.604	21.8	0.42	51.9
$\pm 10^\circ$	0.1170					0.606	1.63	0.24	6.52	0.577	11.8	0.44	26.9
$\pm 12^\circ$	0.1654									0.565	7.6	0.43	17.7
$\pm 14^\circ$	0.2204									0.549	1.2	0.43	2.9

they can be treated as the two eigenvectors of Pauli operator σ_z with eigenvalues $+1$ and -1 , respectively. Adopting the methods of Refs. 26, we consider measurements of linear polarization H/V , and $+/-$ where $|+\rangle = (|H\rangle + |V\rangle)/\sqrt{2}$ and $|-\rangle = (|H\rangle - |V\rangle)/\sqrt{2}$, or of circular polarization R/L , where $|R\rangle = (|H\rangle + i|V\rangle)/\sqrt{2}$ and $|L\rangle = (|H\rangle - i|V\rangle)/\sqrt{2}$, can be represented as the two eigenstates of Pauli operator σ_y , with eigenvalues ± 1 . For the convenience of presentation, we define a measurement of $+/-$ linear polarization as an x measurement and one of R/L circular polarization as a y measurement.

The conflict between the quantum predictions for the GHZ states and local realism can be shown via violation of a suitable Ardehali inequality. In this case taking account of the errors is straightforward. A number of inequalities for n -particle GHZ states have been derived^{17,8,32,33}. According to the optimal Bell inequality for eight-qubit GHZ state⁸, LR imposes a constraint on statistical correlations of polarization measurements on the eight-qubit system as the following

$$|\langle \mathcal{A} \rangle_{LR}| \leq 16 \quad (8)$$

QM predicts $|\langle \mathcal{A} \rangle_{QM}| = 128\sqrt{2}$ with a maximal violation of the constraint of LR by an exponential factor of $8\sqrt{2}$. To measure the

expectation value of \mathcal{A} , we need to perform one hundred and twenty eight measurements such as $\sigma_x^1 \sigma_x^2 \sigma_x^3 \dots \sigma_x^7 \sigma_y^8$ measurement on qubit 8 is obtained if we insert in its path a quarter wave plate, whose optical axis is set at 45° with respect to the horizontal direction. Then, the two eigenstates of operator σ_a are converted into linear polarizations which are polarized along the directions of 22.5° and 67.5° . In the same way, the two eigenstates of operator σ_b can be converted into -67.5° and 22.5° linear polarizations. Substituting the experimental results into the left-hand side of inequality gives $|\langle \mathcal{A} \rangle_{Exp}| = 107.2 \pm 0.45$ which violate the inequality (8) by over $\mathcal{S} = 202.8$ standard deviations, hence demonstrating the largest conflict between QM and LR using an eight qubits hyper-entangled GHZ states.

Next, we experimentally investigate the robustness of the Ardehali inequality for the eight-qubit GHZ states in noisy environment. We define \mathcal{V} as the violation of the Ardehali inequality and the $\mathcal{V} = \langle B \rangle - C_{lhv}$, here C_{lhv} is the up threshold of one inequality for local realism. Then the standard deviations of an entanglement test can be defined as²⁸

$$\mathcal{S} = \mathcal{V} / \mathcal{E} \quad (9)$$

where \mathcal{E} is the statistical error of the experiment. Table I shows our experimental results on the violation, statistical error, and standard

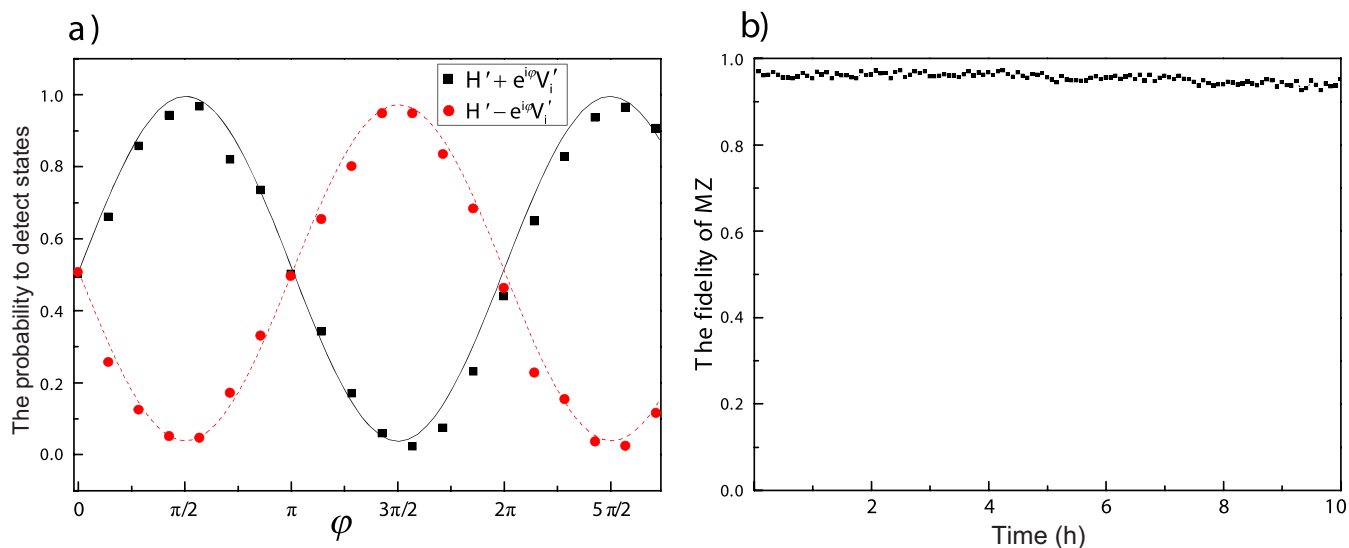

Figure 4 | Experimental results of the visibility and the stability of one interferometer. (a), The phase scanning curves. (b), The passive stability curves (10 hour).



deviation at different noise levels. As a comparison, we give the results of four-bits and six-bits respectively. From the results shown in Table I, it can be seen that with different noise levels the experimental results of the violation, the standard deviations of the Ardehali inequality decrease accordingly. When $\theta = \pm 0^\circ$, the standard deviations of the Bell inequality in our hyper-entangled 8-qubit states is $S = 202.8$. Moreover, when $\theta \geq 14^\circ$ the measured value of Bell operator will not violate the Ardehali inequality. It is worth pointing out that the noise level of $\theta = 14^\circ$ is three times of four photos GHZ states³⁰ and twenty times of three photos GHZ states²⁶, and at this noise level the Ardehali inequality still deviate LR verdict with $S = 2.8$ standard deviations. It proves that the Ardehali inequality in hyper-entangled eight-qubit GHZ states is more robust against stronger noise.

It should be pointed out that the generation of the hyper-entangled state and the observation of the Ardehali inequality using hyperentanglement implies that some of the qubits are carried by the same photon, and, therefore cannot be spatially separated. So our setup cannot be used to close the locality loophole. However, the higher dimension entanglement state is helpful to relax the detection efficiencies required for closing the detection loophole in Bell tests^{13,16}. At the same time, in both approaches, a good measure of nonlocality is the ratio between experimental value and the maximal possible value allowed by the local realistic theories. This measure is related both to the number of qubits needed to communicate nonlocally in order to emulate the experimental results by a local realistic theory, and also to the minimum detection efficiency needed for a loophole-free experiment. In this sense, a higher value of this ratio, we experimentally demonstrated, is a significant step toward a loophole-free Bell test^{34,35}.

In summary, using the hyper-entangled four-photon-eight-qubit GHZ states generated by exploiting both the photons' polarization and spatial degrees of freedom, we experimentally demonstrate the highest qubit Ardehali inequality violation with 203 standard deviations. It is important to point out that the higher violation is a basis for some quantum information processing process such as QKD. Moreover, we experimentally investigated the robustness of the Ardehali inequality for the four, six, eight-qubit GHZ states in a rotary noisy environment systematically and first proved that the Ardehali inequality with a higher qubit is more robust against noise. Our work, besides its significance in quantum foundations, could also be applied to investigate the basic quantum-information processing, such as quantum computation with linear optics³⁶, topological error correction³⁷ and quantum metrology³⁸ and so on.

Methods

Generation of the hyper-entangled four-photon-eight-qubit GHZ states. A mode-locked Ti:sapphire laser outputs an infrared (IR) light pulse with a central wavelength of 780 nm, a pulse duration of 100 fs and a repetition rate of 80 MHz, which passes through a LiB_3O_5 (LBO) crystal and is converted to ultraviolet (UV) light pulse with a central wavelength at 390 nm and average power is 250 mW. Behind the LBO, five dichroic mirrors are used to separate the mixed IR and UV components. The ultraviolet light is focused on two β -barium borate (BBO) crystals to produce two pairs of entangled photons. Prisms $\Delta D1$ is used to ensure that the input photons arrive at the PBS_{23} at the same time. Finally they are detected by fiber-coupled single-photon detectors and the coincidence events are registered by a programmable multichannel coincidence unit. Conceptual interferometer for implementation and analysis of hyper-entanglement. An incoming photon is split into two possible spatial modes by the PBS with regard to its polarization forming an Einstein-Podolsky-Rosen-like entangled state between the photons' spatial and polarization degrees of freedom. A Mach-Zehnder-type interferometer with an NPBS (Seord038088, CASTECH Co.) is used to coherently measure the spatial mode qubit, and subsequently at both of its output ports conventional polarization analysis is carried out. QWP: quarter-wave plate; HWP: half-wave plate. The high visibility and the long-term stability (10 hour) of one interferometer used in our experiment are shown in Fig. 4.

1. Acin, A. *et al.* Device-independent security of quantum cryptography against collective attacks. *Phys. Rev. Lett.* **98**, 230501 (2007).

2. Buhrman, H., Cleve, R., Massar, S. & Wolf, R. D. Nonlocality and communication complexity. *Rev. Modern Phys.* **82**, 665 (2010).
3. Brunner, N. *et al.* Testing the dimension of Hilbert spaces. *Phys. Rev. Lett.* **100**, 210503 (2008).
4. Chuan, T. K. *et al.* Quantum discord bounds the amount of distributed entanglement. *Phys. Rev. Lett.* **109**, 070501 (2012).
5. Ekert, A. K. Quantum cryptography based on Bell's theorem. *Phys. Rev. Lett.* **67**, 661 (1991).
6. Güney, V. U. & Hillery, M. Maximum quantum violations of a class of Bell inequalities. *Phys. Rev. A* **87**, 052126 (2013).
7. Mermin, N. D. Extreme quantum entanglement in a superposition of macroscopically distinct states. *Phys. Rev. Lett.* **65**, 1838 (1990).
8. Ardehali, M. Bell inequalities with a magnitude of violation that grows exponentially with the number of particles. *Phys. Rev. A* **46**, 5375 (1992).
9. Zhao, Z. *et al.* Experimental violation of local realism by four-photon Greenberger-Horne-Zeilinger entanglement. *Phys. Rev. Lett.* **91**, 180401 (2003).
10. Zhao, Z. *et al.* Experimental demonstration of five-photon entanglement and open-destination teleportation. *Nature* **430**, 54 (2004).
11. Lu, C. Y. *et al.* Experimental entanglement of six photons in graph states. *Nature Phys.* **3**, 91 (2007).
12. Yao, X. C. *et al.* Observation of eight-photon entanglement. *Nature Photonics* **6**, 225 (2012).
13. Gao, W. B. *et al.* Bell inequality tests of four-photon six-qubit graph states. *Phys. Rev. A* **82**, 042334 (2010).
14. Barreiro, J. T., Langford, N. K., Peter, N. A. & Kwiat, P. G. Generation of hyperentangled photon pairs. *Phys. Rev. Lett.* **95**, 260501 (2005).
15. Mair, A., Vaziri, A., Weihs, G. & Zeilinger, A. Entanglement of the orbital angular momentum states of photons. *Nature* **412**, 313 (2001).
16. Barbieri, M., Martini, F. D., Mataloni, P., Vallone, G. & Cabello, A. Enhancing the violation of the Einstein-Podolsky-Rosen local realism by quantum hyperentanglement. *Phys. Rev. Lett.* **97**, 140407 (2006).
17. Schuck, C., Huber, G., Kurtsiefer, C. & Weinfurter, H. Complete deterministic linear optics Bell state analysis. *Phys. Rev. Lett.* **96**, 190501 (2006).
18. Gao, W. B. *et al.* Experimental demonstration of a hyper-entangled ten-qubit Schrödinger cat state. *Nature Phys.* **6**, 331 (2010).
19. Barreiro, J. T., Wei, T. C. & Kwiat, P. G. Beating the channel capacity limit for linear photonic superdense coding. *Nature Phys.* **4**, 282 (2008).
20. Chen, K. *et al.* Experimental realization of one-way quantum computing with two-photon four-qubit cluster states. *Phys. Rev. Lett.* **99**, 120503 (2007).
21. Vallone, G., Pomarico, E., Martini, F. D. & Mataloni, P. Active one-way quantum computation with two-photon four-qubit cluster states. *Phys. Rev. Lett.* **100**, 160502 (2008).
22. Lanyon, B. P. *et al.* Simplifying quantum logic using higher-dimensional Hilbert spaces. *Nature Phys.* **5**, 134 (2009).
23. Almeida, M. L., Barrett, S. J., Toth, G. & Acin, A. Noise robustness of the nonlocality of entangled quantum states. *Phys. Rev. Lett.* **99**, 040403 (2007).
24. Bovino, F. A., Castagnoli, G., Cabello, A. & Linares, A. L. Experimental noise-resistant Bell-inequality violations for polarization-entangled photons. *Phys. Rev. A* **73**, 062110 (2006).
25. Clauser, J. F., Horny, M. A., Shimony, A. & Holt, R. A. Proposed experiment to test local hidden-variable theories. *Phys. Rev. Lett.* **23**, 880 (1969).
26. Lu, H. X., Zhao, J. Q., Cao, L. Z. & Wang, X. Q. Experimental investigation of the robustness against noise for different Bell-type inequalities in three-qubit Greenberger-Horne-Zeilinger states. *Phys. Rev. A* **84**, 044101 (2011).
27. Lu, H. X., Zhao, J. Q. & Wang, X. Q. Characterization of a high-intensity three-qubit GHZ state using state tomography and Gisin's inequality. *Phys. Lett. A* **375**, 1850 (2011).
28. Lu, H. X., Zhao, J. Q., Wang, X. Q. & Cao, L. Z. Experimental demonstration of tripartite entanglement versus tripartite nonlocality in three-qubit Greenberger-Horne-Zeilinger class states. *Phys. Rev. A* **84**, 012111 (2011).
29. Chen, Y. A., Zhang, A. N., Zhao, Z., Zhou, X. Q. & Pan, J. W. Experimental quantum error rejection for quantum communication. *Phys. Rev. Lett.* **96**, 220504 (2006).
30. Jungnitsch, B. *et al.* Increasing the statistical significance of entanglement detection in experiments. *Phys. Rev. Lett.* **104**, 210401 (2010).
31. Ryff, L. C. Bell and Greenberger, Horne, Zeilinger theorems revisited. *Am. J. Phys.* **65**, 1197 (1997).
32. Belinskii, A. V. & Klyshko, D. N. Interference of light and Bell's theorem. *Phys. Usp.* **36**, 653 (1993).
33. Żukowski, M. Bell theorem involving all settings of measuring apparatus. *Phys. Lett. A* **177**, 290 (1993).
34. Almeida, M. L., Pironio, S., Barrett, J., Toth, G. & Acin, A. Noise robustness of the nonlocality of entangled quantum states. *Phys. Rev. Lett.* **99**, 040403 (2007).
35. Brunner, N., Young, A. B., Hu, C. Y. & Rarity, J. G. Proposal for a loophole-free Bell test based on spin-photon interactions in cavities. *New J. Phys.* **15**, 105006 (2013).
36. Pan, J. W. *et al.* Multiphoton entanglement and interferometry. *Rev. Mod. Phys.* **84**, 777 (2012).
37. Yao, X. C. *et al.* Experimental demonstration of topological error correction. *Nature* **482**, 489 (2012).



38. Jin, X. M. *et al.* Sequential path entanglement for quantum metrology. *Sci. Rep.* **3**, 1779 (2013).

Acknowledgments

We thank C. Lu, W. Gao, and O. Gühne for valuable discussions. This work was supported by the Natural Science Foundation of China (Grant No.11174224), the Natural Science Foundation of Shandong Province (Grant No.ZR2011AL012, ZR2013FM001, 2013SJGZ10), the Science and Technology Development Program of Shandong Province(Grant No.2011YD01049), and Higher School Science and Technology Program of Shandong Province(Grant No.J13LJ54).

Author contributions

H.X.L., L.Z.C. and J.Q.Z. had the idea for and initiated the experiment. H.X.L., Y.D.L. and X.Q.W. contributed to the general theoretical work. H.X.L., L.Z.C. and J.Q.Z. designed the

experiment. J.Q.Z. and L.Z.C. carried out the experiment. Y.D.L. and X.Q.W. analysed the data. H.X.L., L.Z.C. and J.Q.Z. wrote the manuscript. H.X.L. supervised the whole project.

Additional information

Competing financial interests: The authors declare no competing financial interests.

How to cite this article: Lu, H.-X., Cao, L.-Z., Zhao, J.-Q., Li, Y.-D. & Wang, X.-Q. Extreme violation of local realism with a hyper-entangled four-photon-eight-qubit Greenberger-Horne-Zelinger state. *Sci. Rep.* **4**, 4476; DOI:10.1038/srep04476 (2014).



This work is licensed under a Creative Commons Attribution-NonCommercial-NoDerivs 3.0 Unported license. To view a copy of this license, visit <http://creativecommons.org/licenses/by-nc-nd/3.0>