

Is Vestibular Self-Motion Perception Controlled by the Velocity Storage? Insights from Patients with Chronic Degeneration of the Vestibulo-Cerebellum

Giovanni Bertolini^{1,2*}, Stefano Ramat², Christopher J. Bockisch^{1,3,4}, Sarah Marti¹, Dominik Straumann¹, Antonella Palla¹

1 Department of Neurology, Zurich University Hospital, Zurich, Switzerland, **2** Department of Computer Science, University of Pavia, Pavia, Italy, **3** Department of Otorhinolaryngology, Head and Neck Surgery, Zurich University Hospital, Zurich, Switzerland, **4** Department of Ophthalmology, Zurich University Hospital, Zurich, Switzerland

Abstract

Background: The rotational vestibulo-ocular reflex (rVOR) generates compensatory eye movements in response to rotational head accelerations. The velocity-storage mechanism (VSM), which is controlled by the vestibulo-cerebellar nodulus and uvula, determines the rVOR time constant. In healthy subjects, it has been suggested that self-motion perception in response to earth-vertical axis rotations depends on the VSM in a similar way as reflexive eye movements. We aimed at further investigating this hypothesis and speculated that if the rVOR and rotational self-motion perception share a common VSM, alteration in the latter, such as those occurring after a loss of the regulatory control by vestibulo-cerebellar structures, would result in similar reflexive and perceptual response changes. We therefore set out to explore both responses in patients with vestibulo-cerebellar degeneration.

Methodology/Principal Findings: Reflexive eye movements and perceived rotational velocity were simultaneously recorded in 14 patients with chronic vestibulo-cerebellar degeneration (28–81yrs) and 12 age-matched healthy subjects (30–72yrs) after the sudden deceleration ($90^\circ/s^2$) from constant-velocity ($90^\circ/s$) rotations about the earth-vertical yaw and pitch axes. rVOR and perceived rotational velocity data were analyzed using a two-exponential model with a direct pathway, representing semicircular canal activity, and an indirect pathway, implementing the VSM. We found that VSM time constants of rVOR and perceived rotational velocity co-varied in cerebellar patients and in healthy controls (Pearson correlation coefficient for yaw 0.95; for pitch 0.93, $p < 0.01$). When constraining model parameters to use the same VSM time constant for rVOR and perceived rotational velocity, moreover, no significant deterioration of the quality of fit was found for both populations (variance-accounted-for > 0.8).

Conclusions/Significance: Our results confirm that self-motion perception in response to rotational velocity-steps may be controlled by the same velocity storage network that controls reflexive eye movements and that no additional, e.g. cortical, mechanisms are required to explain perceptual dynamics.

Citation: Bertolini G, Ramat S, Bockisch CJ, Marti S, Straumann D, et al. (2012) Is Vestibular Self-Motion Perception Controlled by the Velocity Storage? Insights from Patients with Chronic Degeneration of the Vestibulo-Cerebellum. PLoS ONE 7(6): e36763. doi:10.1371/journal.pone.0036763

Editor: Mark W. Greenlee, University of Regensburg, Germany

Received: July 6, 2011; **Accepted:** April 9, 2012; **Published:** June 15, 2012

Copyright: © 2012 Bertolini et al. This is an open-access article distributed under the terms of the Creative Commons Attribution License, which permits unrestricted use, distribution, and reproduction in any medium, provided the original author and source are credited.

Funding: This work was supported by the Swiss National Science Foundation #32323B_119376; the Betty and David Koetser Foundation for Brain Research; the Baasch Medicus Foundation and the Zurich Center for Integrative Human Physiology. The funders had no role in study design, data collection and analysis, decision to publish, or preparation of this manuscript.

Competing Interests: The authors have declared that no competing interests exist.

* E-mail: bertoweb@gmail.com

Introduction

In the absence of visual cues, it is mainly the vestibular system providing the brain with a sense of body and spatial orientation. The semicircular canals detect rotational movements and the otolith organs detect translational movements as well as the orientation of the head relative to gravity. Specifically, the semicircular canals sense angular and the otolith organs sense linear acceleration. Thus, when the head moves at a constant angular velocity, after an initial deflection, the cupula of the sensory organ passively returns to its resting position resulting in a decay of the firing rate of the vestibular nerve and, therefore, in a decrease of movement sensation. The semicircular canal

cupular time constant has been estimated to range between 3 and 7 seconds [1,2,3,4,5,6,7,8,9]. The vestibular nystagmus that emerges from a constant-velocity rotation in darkness (i.e. the compensatory eye movements evoked by a head rotation), however, outlasts the duration of the semicircular canal input. It is currently believed that a central brainstem and cerebellar network, known as the velocity storage mechanism, prolongs the semicircular canal afferent signal, extending the duration of reflexive eye movements and improving the compensatory response to low-frequency head rotations [8,10,11].

Although the concept of the velocity storage mechanism has been developed based on reflexive eye movements, Okada et al. have suggested that this velocity storage mechanism is also present

at higher-level cortical processes such as in rotational self-motion perception [12]. Our recent observations in healthy human subjects support such hypothesis as we found that self-motion perception after the sudden deceleration from constant-velocity rotations (i.e. angular velocity steps) could be modeled using the same central velocity storage element as the rotational vestibulo-ocular reflex (rVOR) [13]. In contrast to the current opinion [12,14], therefore, our results suggested that no additional, e.g. cortical, mechanisms are required to explain the perceptual dynamics in healthy subjects and, thus, corroborate the hypothesis that the velocity storage mechanism plays an important role also in self-motion perception. In the present study, we aimed at further investigating this hypothesis. Specifically, we speculated that if our hypothesis about a common velocity storage mechanism in the rVOR and in rotational self-motion perception is correct, a dysfunction of velocity storage would result in similar changes in reflexive and perceptual responses.

The velocity storage mechanism is modulated by the vestibulo-cerebellum, specifically the nodulus and ventral uvula [15]. Lesions of these structures impair the ability to realign the eye velocity vector towards the gravito-inertial acceleration vector, i.e. the ability to transform sensory signals encoded in a head-fixed reference frame into a gravitational (i.e. spatially linked) reference frame, a behavior typically attributed to the velocity storage mechanism [16,17,18,19,20,21,22,23,24,25,26,27,28]. The influence of the nodular and uvular structures on the velocity storage activity regarding the control of the time constant of rVOR responses, however, is less clear. Large nodular lesions in monkey, for example, lengthen the overall duration of horizontal rVOR

responses, while more circumscribed medial lesions, apparently, slightly shorten them [15,17,23,29]. Similarly, ambiguous findings are reported in humans where even in comparable nodular lesions due to ischemic strokes, some authors observed prolonged horizontal rVOR responses during earth-vertical axis rotations [26], while others found the rVOR duration ranging within normal limits [27,28]. It has been suggested that these discrepancies resulted from a heterogeneous distribution pattern of affected vestibulo-cerebellar structures [23].

To investigate our hypothesis, namely whether the rVOR and rotational self-motion perception share a common velocity storage mechanism, we decided to explore perceptual and reflexive eye movement responses in patients with midline cerebellar lesions. Even though we could not predict the effect of the cerebellar lesions on the duration of both responses, i.e. whether we would find a prolongation or shortening of the responses, we, nevertheless, expected to find a correlation of both responses in the case of a common velocity storage mechanism. Alternatively, the lack of correlation would imply that vestibular signals for rotational self-motion perception are further processed, possibly at a more rostral level in the central nervous system.

Methods

Subjects

14 patients (4 females; mean age 53 yrs, range 28–81yrs) with chronic degeneration of the vestibulo-cerebellum due to hereditary or sporadic disease (see Table 1) and 12 age-matched healthy subjects (5 females; mean age 56 yrs, range 30–72 yrs) participated

Table 1. Diagnosis, most prominent clinical and MRI findings in cerebellar patients.

Patient No., gender, age (y)	Diagnosis	Main clinical findings	Brain MR
1, m, 66	SAOA	DBN, GEN, SP, GA	slight atrophy of VestCb
2, m, 70	SAOA	DBN, GEN, SP, GA	moderate atrophy of V
3, m, 81	SAOA	DBN, GEN, saccadic SP, GA	severe atrophy of VestCb
4, f, 34	most probably sporadic	GA, LA, upper limb rebound phenomenon	slight atrophy of V and cerebellar hemispheres
5, m, 78	SAOA	DBN, GEN, GA, (SP), (LA)	severe atrophy of VestCb and cerebellar hemispheres
6, f, 57	probably immune-mediated (Glutenataxia)	DBN, GA, SP	no atrophy
7, m, 66	SAOA	(DBN), SP, GEN, Dysarthria, (GA), (LA)	severe atrophy of V and cerebellar hemispheres
8, m, 35	hereditary or sporadic	GA, (LA), Dysarthria, (SP)	slight atrophy of V and cerebellar hemispheres
9, m, 38	ADCA III	DBN, GEN, GA, Dysarthria	atrophy of V and cerebellar hemispheres
10, m, 45	ADCA III	(DBN), SP, GEN, GA, LA, Dysarthria	severe atrophy of V and cerebellar hemispheres
11, m, 28	most probably hereditary	GA, (LA), (SP)	severe atrophy of V and cerebellar hemispheres
12, m, 39	probably ADCA III	DBN, GEN, SP	slight atrophy of V and cerebellar hemispheres
13, f, 66 *	SAOA	(DBN), GEN, SP, ocular flutter, (GA)	slight atrophy of VestCb, cerebellar hemispheres, and colliculus superior
14, m, 51 *	most probably ADCA III	(DBN), GEN, saccadic SPEM, GA, (LA)	slight atrophy of V and cerebellar hemispheres

Definitive or suspected diagnosis, most prominent clinical and MRI findings in the 14 patients studied. Sporadic adult onset ataxia (SAOA); Autosomal-dominantly inherited cerebellar ataxia type III (ADCA III); Downbeat nystagmus (DBN); Gait ataxia (GA); Horizontal gaze evoked nystagmus (GEN); Limb ataxia (LA); Impaired horizontal smooth pursuit eye movements (SP); Vermis (V); Vestibulo-cerebellum (VestCb). Patient No 9 and No 10 are brothers. *: two patients only tested during earth-vertical yaw axis, because of reported motion sickness during earth-vertical pitch rotations.

doi:10.1371/journal.pone.0036763.t001

in the study. Informed consent of all participants was obtained in written form after full explanation of the experimental procedure. The protocol was approved by the Ethics Committee of the Canton of Zurich, Switzerland (Protocol N°E-33/2007), and was in accordance with the ethical standards laid down in the 1964 Declaration of Helsinki for research involving human subjects.

Experimental Setup

Participants were seated on a turntable with three servo-controlled motor-driven axes (prototype built by Acutronic, Switzerland). They were positioned so that the intersection of the inter-aural and naso-occipital axes was at the intersection of the three axes of the turntable. The head was restrained with an individually molded thermoplastic mask (Sinmed BV, Recuwijk, The Netherlands). Pillows and safety belts minimized movements of the body.

Recording of rotational self-motion perception. Participants were asked to turn a lever attached to a potentiometer that was fixed to the chair. The instruction was to match the rate of lever spinning with the perceived rotational velocity and to stop spinning when the rotation was not felt anymore (for details about instructions see [13]). To avoid additional sensory cues possibly biasing 'pure' vestibular rotatory sensation (e.g. auditory cues and/or proprioceptive cues due to chair vibration and/or airflow, which might prolong the vestibular induced spinning sensation during constant velocity rotation) white noise was delivered through headphones and only postrotatory responses (i.e. data collected after stopping the turntable) were analyzed [12]. Experimental instructions were always given by the same experimenter (A.P.) to guarantee consistent information among all participants.

Recording of eye movements. Three-dimensional eye movements were recorded monocularly with scleral search coils (Skalar Instruments, Delft, Netherlands) after anesthetizing the conjunctiva with 0.4% Oxybuprocaine. Search coil annuli were calibrated with a method described elsewhere [30]. A turntable-fixed aluminum coil frame (side length 0.5 m) surrounded the head and generated three orthogonal digitally synchronized magnetic wave fields of 80, 96, and 120 kHz. Technical details about data acquisition were described previously [13].

Experimental Procedure

Participants were rotated in complete darkness about the earth-vertical axis while seated upright (yaw rotation with predominant horizontal semicircular canal activation) or lying on their left side (pitch rotation with predominant vertical semicircular canal activation). Two patients (indexed as 13 and 14 in Table 1) were rotated about the earth-vertical yaw axis only due to motion sickness during earth-vertical pitch rotations. Data of single participants was obtained during a single session recorded at a determined day.

Within the same session, recordings were restricted to four trials of yaw and four trials of pitch rotations, as habituation of the rotational vestibulo-ocular reflex and of the sensation of self-rotation takes place after ten consecutive trials of steps of angular velocity about the yaw axis [31]. By restricting the number of trials, we also avoided effects of decreasing alertness. Because of this trial restriction and in order to investigate the reproducibility of the perceptual response, however, passive rotations (angular velocity: $90^\circ/s$; acceleration and deceleration: $90^\circ/s^2$; duration: 90 s) were delivered only in counterclockwise direction (i.e. positive rotation about the upward pointing space-fixed z-axis according to the right-hand rule [32]). This corresponded to a participant's backward rotation when lying on the left side.

Postrotatory recording in darkness continued until nystagmus (leftward beating in upright position and upward beating in 90° left ear down position) decayed to zero and participants indicated that their perception of rotational motion had vanished. Yaw and pitch rotation trials were pseudo-randomly intermingled for each participant. Between rotation trials, a 30 s to 1 minute break was given with the test room illuminated.

Data analysis

Parameter estimation. A model previously developed for monkeys representing the step responses of the rotational vestibulo-ocular reflex (rVOR) was fitted to our data [10,33]. Figure 1 (solid lines) provides a graphical representation of this model together with an example of the slow-phase eye velocity responses of one cerebellar patient (indexed as 8 in Table 1) to one trial of earth-vertical yaw rotation (gray trace in insert C). The function that generates the curve that best fits slow-phase eye velocity (bold trace in insert C) can be divided into two components. The first, accounting for the semicircular canal activity, is a single exponential with a time constant τ_C and is shown in the figure by solid thin traces (see inserts A and C). The second component of the function represents the central processing called the velocity storage mechanism and is the difference of two exponentials with two different time constants, τ_C and τ_{VSM} . It is depicted as dashed traces (see inserts B and C).

The mathematical function describing the curve fit, i.e. the step response of the rVOR is:

$$\dot{\theta} = g_D e^{-t/\tau_C} + g_I \frac{\tau_C \tau_{VSM}}{\tau_C - \tau_{VSM}} \left(e^{-t/\tau_C} - e^{-t/\tau_{VSM}} \right)$$

where τ_C and τ_{VSM} are the semicircular canal and velocity storage time constants, respectively, and g_D and g_I are the gains, i.e. the strength or weight of the peripheral and central contributions (for further details on the mathematical description of the model see [13,34]). All parameter were iteratively optimized using a nonlinear least-squares algorithm. In order to minimize the impact of approximating a 'pure' step response by the actual $90^\circ/s^2$ ramp response used in this study, the end of chair deceleration phase was set at $t=0$ and used as first data point of the data fitting procedure.

In a previous study in healthy subjects we demonstrated that the same function could be used to fit perceived rotational velocity during step responses [13]. Notably, the accuracy of the fit did not decrease when restraining the model to use the same τ_C and τ_{VSM} for both slow-phase eye velocity and perceived rotational velocity, suggesting the existence of a common – or at least an equivalent – central processing of reflexive eye movements and self-motion perception. The dashed-dotted lines in figure 1 represent the assumption that self-motion perception and eye movements share a common central processing. In the following, the model will be applied to our data without and with the constraint of a common central processing, i.e. by letting τ_{VSM} free to change or by using the same τ_{VSM} . Note that the assumption about the model constraint holds only for the time constants τ_C and τ_{VSM} , whereas g_D and g_I , i.e. the relative weighting of the peripheral and central pathways, will be left free to change. This is justified since the two gains do not model the time constant substitution accomplished by the velocity storage mechanism, but just the balancing between the velocity storage contribution and the direct semicircular canals signal. Even assuming a common velocity storage, this weighting can easily be different for reflexes and perception as it can occur independently from the velocity storage processing.

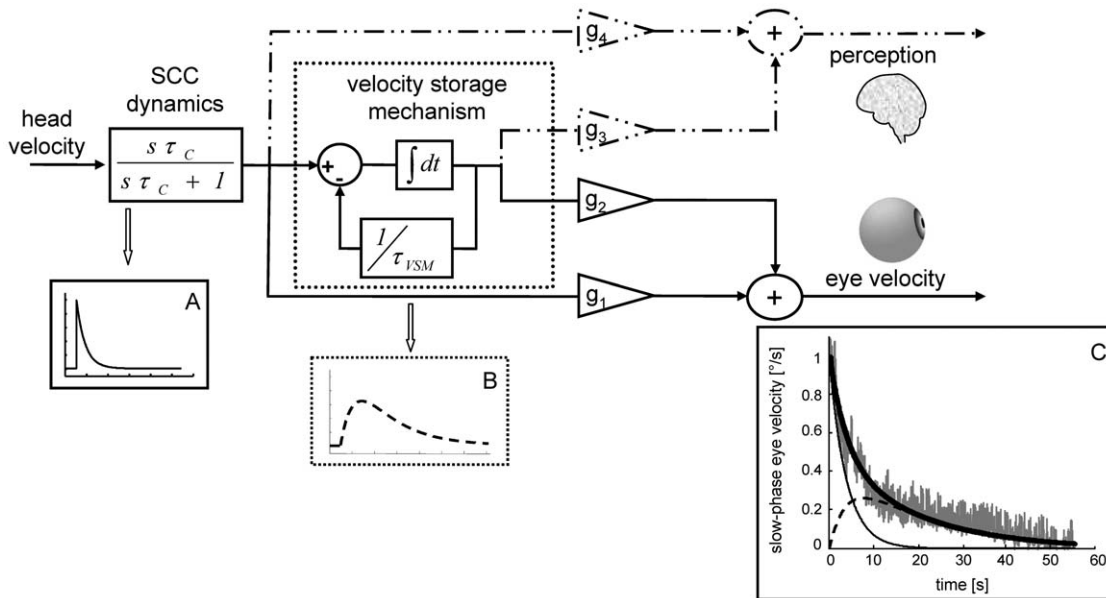

Figure 1. Proposed model structure according to the Raphan, Cohen, and Matsuo model with corresponding modifications for self-motion perception. Block diagram representation of the velocity storage model as previously developed for the rotational vestibulo-ocular reflex (solid lines) [10,33] and recently modified [13] for rotational self-motion perception (dashed-dotted lines) under the assumption of a common central processing (see text for details). Insert A: Example of the output of the block accounting for the semicircular canal (SCC) dynamics. Insert B: Example of the output of the block representing the central velocity storage mechanism. Insert C: Output of the model (bold black line) generating a curve that best fits slow-phase eye velocity responses (gray traces) of the rotational vestibulo-ocular reflex. The thin and dashed black lines in insert C represent the two components (SCC and velocity storage mechanism) generating the overall data fit (bold line). g_{1-4} : gains, i.e. strength or weight of individual pathway contributions.
doi:10.1371/journal.pone.0036763.g001

Statistical analysis. Normal distribution of time constants and gains of each participant was evaluated using Lilliefors test. Pearson correlation coefficients were used for co-variance analysis of τ_{VSM} estimates resulting from the model fit of slow-phase eye velocity and perceived rotational velocity without the ‘common central processing’ parameter constraint; p values less than 0.05 were considered significant. A measure of the goodness of fit of the model with and without the τ_{VSM} constraint was, furthermore, provided by the variance-accounted-for technique [35]. Finally, Bayesian information criterion was computed as a measure of the adequacy of model complexity [36]. Whereas the variance-accounted-for measure provides a goodness of fit criterion that is independent of the number of parameters in the fitting model, the Bayesian information criterion takes the number of parameters into account, ‘penalizing’ more complex models for the overfitting. Variance-accounted-for values should be larger to indicate a superior fit, whereas Bayesian information criterion values should be lower to indicate a more appropriate model. Bayesian information criterion (BIC) was calculated as follows [37]:

$$BIC = \frac{N}{\sigma^2_{err}} (MSE + \log(N) * \frac{d}{N})$$

where N is the overall number of data points, d is the number of model parameters, MSE is the mean squared error and σ^2_{err} is the variance of the error.

Results

As outlined previously (see Figure 1), slow-phase eye velocity and perceived rotational velocity responses to velocity steps of earth-vertical yaw and earth-vertical pitch rotations were fitted by

Table 2. Best fit parameters of simulated slow-phase eye velocity and perceived rotational velocity curves.

	cerebellar patients	healthy controls	p-value
unconstrained fit			
<i>yaw rotations</i>			
τ_c	4.2 ± 1.1	5.0 ± 1.2	p = 0.07
$\tau_{VSM} (eye)$	14.6 ± 3.8	17.4 ± 4.4	p = 0.10
$\tau_{VSM} (perception)$	14.4 ± 3.7	13.9 ± 7.1	p = 0.81
<i>pitch rotations</i>			
τ_c	4.0 ± 1.0	4.8 ± 1.0	p = 0.09
$\tau_{VSM} (eye)$	8.8 ± 4.3	5.3 ± 3.2	p = 0.06
$\tau_{VSM} (perception)$	9.7 ± 4.6	7.4 ± 5.3	p = 0.29
constrained fit			
<i>yaw rotations</i>			
τ_c	4.4 ± 1.3	5.1 ± 1.3	p = 0.18
τ_{VSM}	14.4 ± 3.8	15.3 ± 4.2	p = 0.59
<i>pitch rotations</i>			
τ_c	4.4 ± 1.4	5.0 ± 1.3	p = 0.30
τ_{VSM}	9.3 ± 4.5	6.0 ± 3.0	p = 0.06

Best fit parameters of simulated slow-phase eye velocity and perceived rotational velocity curves in cerebellar patients and in age-matched healthy obtained with and without constraining the velocity-storage time constant (τ_{VSM}). Values are means ± 1SD. τ_c : estimated peripheral semicircular canal time constants; τ_{VSM} : estimated central velocity storage time constants.
doi:10.1371/journal.pone.0036763.t002

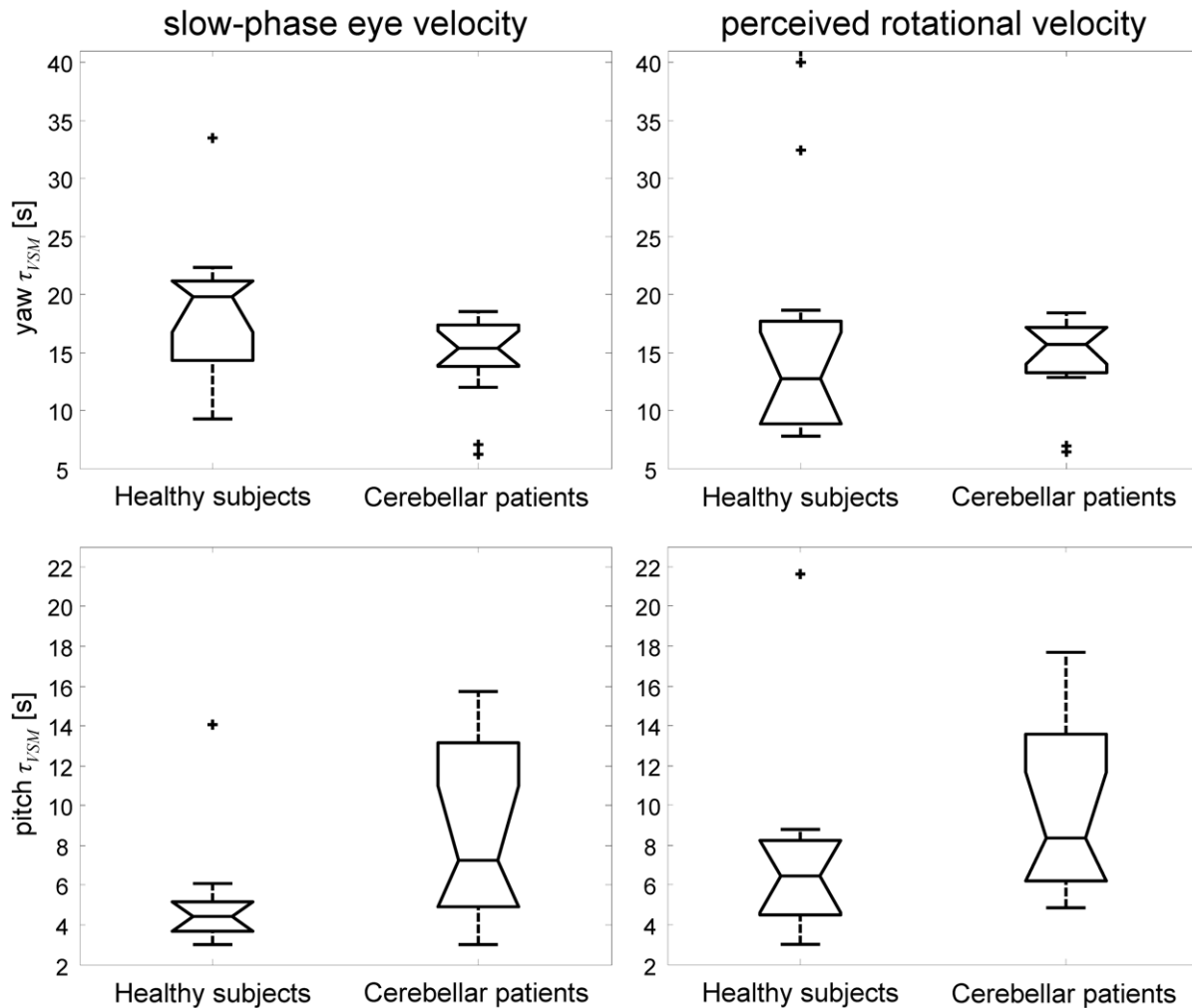

Figure 2. Comparison of velocity storage time constants of reflexive eye and perceptual responses in healthy subjects and cerebellar patients. Box plot representation of velocity storage time constant (τ_{VSM}) estimates in healthy subjects and cerebellar patients. Unconstrained model fit, i.e. fitting procedure with τ_{VSM} free to change for reflexive eye and perceptual responses. Note the different time scales for yaw and pitch rotations. Although no significant difference was found between τ_{VSM} for reflexive and perceptual responses, values estimated from pitch responses (left and right bottom graphs) show a larger τ_{VSM} spread in patients compared to healthy subjects. doi:10.1371/journal.pone.0036763.g002

the sum of two exponentials: one with a time constant accounting for the peripheral, i.e. semicircular canal (τ_C), and another with a time constant accounting for the central, i.e. velocity storage (τ_{VSM}), dynamics.

Slow-phase eye velocity and perceived rotational velocity responses were first fitted by letting τ_{VSM} free to change (see *Data analysis* in Methods for further details). This allowed us to explore the relation of τ_{VSM} of eye movements and τ_{VSM} of perception responses without assuming any shared central processing. Recall, that, however, as a logical consequence of the simultaneous recording of eye movement and perception data, we constrained the model to use the same semicircular canal time constant τ_C for fitting slow-phase eye velocity and perceived rotational velocity. Estimated model parameters are presented in Table 2 (see unconstrained fit). For comparison, values from age-matched healthy controls are also provided. Time constants of all samples were normally distributed and no statistical differences between patients and healthy controls were found during both yaw and pitch rotations (paired t-test $p > 0.1$).

Figure 2 provides a graphical representation of τ_{VSM} values between patients and healthy subjects. Note that even though overall τ_{VSM} was not statistically different between both groups, during pitch rotations τ_{VSM} are spread over a wider range in the cerebellar patients.

The model function used to fit the data has previously been shown to be accurately applicable in healthy subjects [13]; its performance in the pathophysiological condition of cerebellar atrophy, however, has still to be proven. The goodness of fit (variance-accounted-for) in cerebellar patients for slow-phase eye velocity and for perceived rotational velocity was 0.83 ± 0.09 and 0.87 ± 0.07 during yaw rotations, and 0.80 ± 0.16 and 0.89 ± 0.06 during pitch rotations, respectively. Thus, also in cerebellar patients, self-motion perception and reflexive eye movement curves were fitted well by the model.

τ_{VSM} of slow-phase eye velocity and perceived rotational velocity during trials of earth-vertical yaw and during trials of earth-vertical pitch rotations covaried in all cerebellar patients (Pearson correlation coefficient between rVOR τ_{VSM} and perception τ_{VSM} : 0.95 for yaw and 0.93 for pitch, $p < 0.001$),

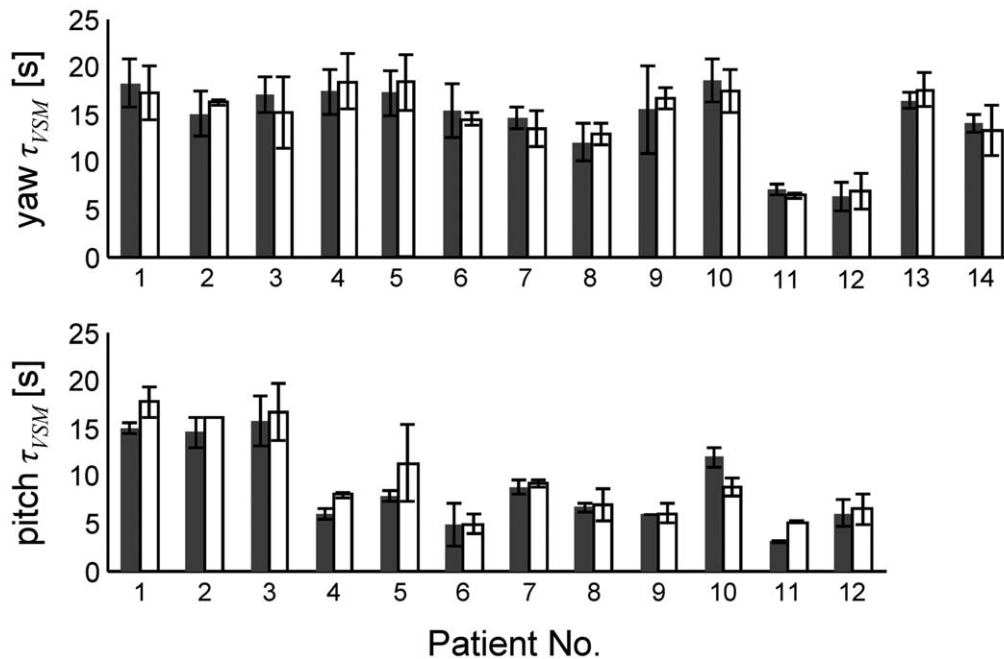

Figure 3. Velocity storage time constants of reflexive eye and perceptual responses. Comparison of the time constants (mean \pm SD) describing the velocity storage activity (τ_{VSM}) between slow-phase eye velocity (gray bars) and perceived rotational velocity (white bars) obtained by the model when letting τ_{VSM} free to change. Each block of two bars represents the results in one subject. Two patients were rotated about the earth-vertical yaw axis only, because they reported motion sickness during earth-vertical pitch rotations. doi:10.1371/journal.pone.0036763.g003

indicating a possible link between the central time constant τ_{VSM} of slow-phase eye velocity and perceived rotational velocity. Figure 3 shows τ_{VSM} of slow-phase eye velocity and perceived rotational velocity (mean \pm SD of all yaw and pitch traces) in individual patients.

We subsequently constrained the model to use the same τ_{VSM} for fitting slow-phase eye velocity and perceived rotational velocity traces. Estimated model parameters with constrained τ_{VSM} are presented in Table 2 (see constrained fit). For comparison, values from age-matched healthy controls are also provided. As for unconstrained τ_{VSM} parameters, time constants of all samples were normally distributed and no statistical differences between patients and healthy controls were found during both yaw and pitch rotations (paired t-test $p > 0.1$).

Similar to the unconstrained model condition, we found that cerebellar eye velocity and perceptual curves were fitted well by the model (variance-accounted-for during yaw rotations: 0.82 ± 0.10 for slow-phase eye velocity and 0.86 ± 0.05 for perceived rotational velocity; during pitch rotations: 0.80 ± 0.13 for slow-phase eye velocity and 0.88 ± 0.07 for perceived rotational velocity). The eligibility of the model when reducing the number of parameters by using the same τ_{VSM} was additionally evaluated using the Bayesian information criterion (see *Statistical analysis* in Methods). With the model constrained to use the same τ_{VSM} for fitting slow-phase eye velocity and perceived rotational velocity traces, Bayesian information criterion over all patients was 89 ± 17 for yaw and 58 ± 15 for pitch rotations, respectively. Such Bayesian information criterion values were not significantly different from those obtained when allowing the optimization procedure to vary τ_{VSM} values for fitting slow-phase eye velocity and perceived rotational velocity (Bayesian information criterion values: 103 ± 27 for yaw and 66 ± 16 for pitch rotations; paired t-test for values obtained during yaw and pitch rotations: $p > 0.1$).

Figure 4 and 5 show slow-phase eye velocity and perceived rotational velocity traces during yaw and pitch rotations in typical cerebellar patients and in a healthy age-matched subject. Figure 5 moreover highlights the wide spread of reflexive and perceptual responses found for pitch rotations in cerebellar patients.

From both figures one can also infer that the main characteristics of slow-phase eye velocity and perceived rotational velocity responses were similar in our patients and in healthy subjects. Specifically, slow-phase eye velocity showed an almost immediate rise followed by a slower decay approximating a single exponential curve, while perceived rotational velocity rise is followed by a plateau-like phase. The latter is especially evident in patients having a long τ_{VSM} , such as the one shown in the first column of Figure 5. We previously found and explained this plateau-like behavior by proposing an increased relative weighting of the central velocity storage activity (for details about the qualitative description of reflexive and perceptual responses see [13]).

Values of gain ratios of the velocity storage component to the semicircular canals component in cerebellar and healthy subjects are provided in Table 3. Note that only arbitrarily scaled gains can be defined for perception of rotational velocity using a magnitude estimation method as done in this study [38]. Therefore the fitting procedure allows only to draw conclusions about the relative gain ratio between the direct, i.e. semicircular canals, and the indirect, i.e. velocity storage, pathways. A significant increase of the relative strength of the perceptual velocity storage pathway can be, nevertheless, seen in cerebellar patients for both yaw and pitch rotations and is in line with healthy subjects (see [13]).

Discussion

In patients with chronic degeneration of the vestibulo-cerebellum due to hereditary or sporadic disease, we studied the vestibulo-ocular reflex and self-motion perception after a sudden

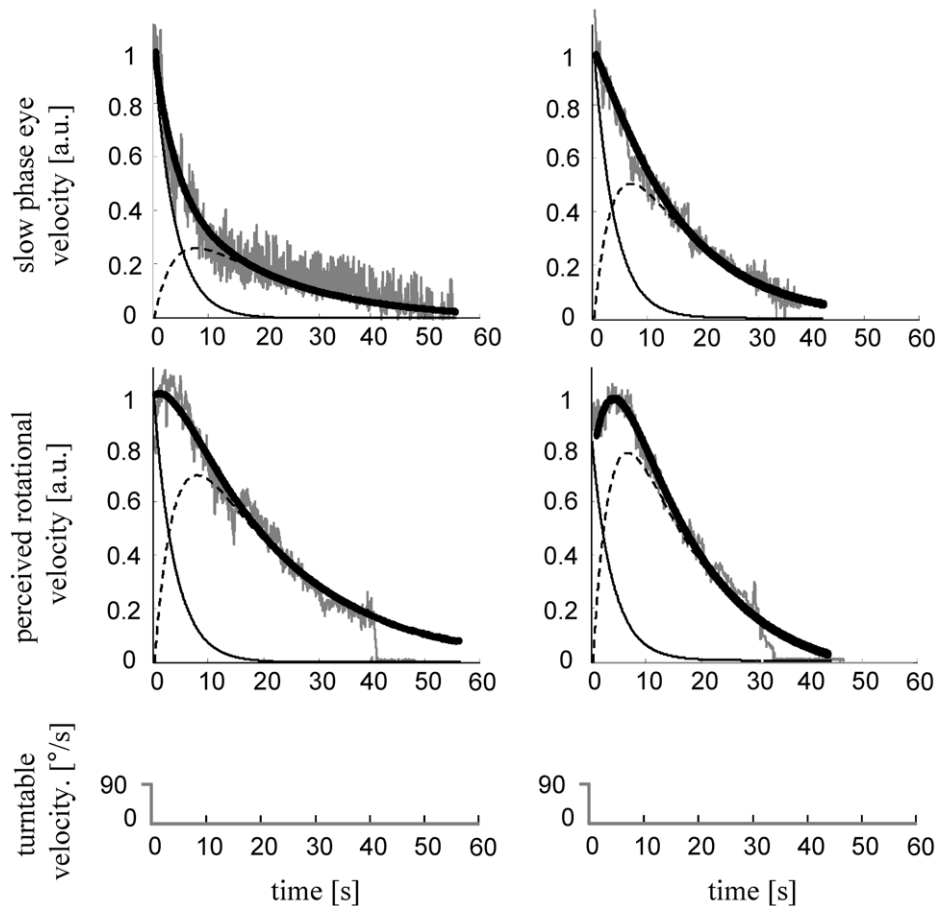

Figure 4. Variability of reflexive eye and perceptual responses in two cerebellar patients during yaw rotations. Slow-phase eye velocity and perceived rotational velocity responses with corresponding simulated curves in one patients (patient no. 8 [left column]) and one healthy subject (right column) after the sudden stop from an earth-vertical yaw rotation. doi:10.1371/journal.pone.0036763.g004

stop from a sustained rotation about the earth-vertical axis (angular velocity step response) while seated either in the upright position (earth-vertical yaw rotation) or lying on the left side (earth-vertical pitch rotation). We aimed to investigate whether the loss of the regulatory control of the brainstem velocity-storage mechanism by midline cerebellar structures due to cerebellar atrophy would induce similar changes in rotational self-motion perception and in reflexive eye movements. Such finding would emphasize a possible sharing of the velocity storage mechanism between the rotational vestibulo-ocular reflex (rVOR) and self-motion perception. Results from this study support that hypothesis.

We found that reflexive eye movement and self-motion perception responses to an angular velocity step behaved similarly. By using a model originally developed for reflexive eye movements [10,33] and recently adapted for explaining perceptual responses in healthy subjects [13], we specifically were able to accurately fit both rVOR and self-motion perception and observed a covariation of the estimated reflexive and perceptual central time constants, these latter representing the velocity storage activity (see Fig. 1). When restraining the model to use the same central time constant for reflexive and perceptual responses, moreover, fitting accuracy was maintained, which reinforces our hypothesis about a possible common velocity storage mechanism in reflexive eye movements and self-motion perception.

A correlation of vestibulo-ocular and vestibulo-perceptual responses has previously been shown by Bronstein et al. in a similar population of patients with midline cerebellar degeneration [39]. While Bronstein et al. [39], however, determined the overall decay time constant of reflexive and perceptual responses, the present study provides a deeper insight into the possible role of the brainstem velocity storage mechanism itself. Specifically, the model-based approach allowed us to separate the peripheral (i.e. semicircular canal) and central (i.e. velocity storage) dynamics that contribute to the rVOR, and, thus, to estimate the parameters determining the contribution of velocity storage mechanism. The fact that perceptual responses could be accurately simulated by the same model architecture that was originally developed for the rVOR and – even more importantly – by restraining the model to use the same central time constant as for reflexive eye movement responses enforces our hypothesis of a common brainstem velocity storage mechanism in perceptual and vestibulo-ocular responses. The presence of similar rotational response dynamics reflecting velocity storage properties in thalamic and vestibular nuclei neurons [40,41,42,43,44], moreover, underpin our assumption that – at least for angular velocity step stimuli – a further perceptual, presumably cortical, processing is not necessary. Of course, we cannot rule out the possibility that different neuronal subgroups within the velocity storage mechanism contribute to reflexive and perceptual responses, as the velocity storage

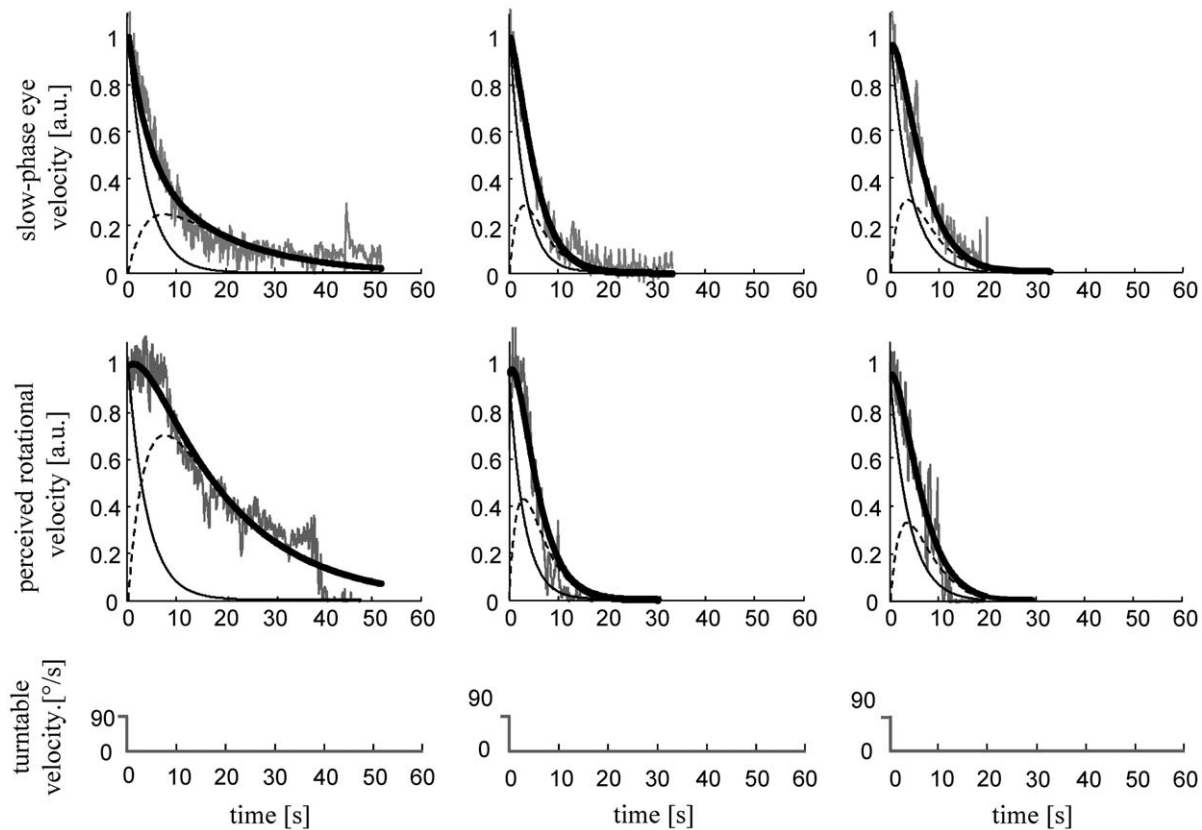

Figure 5. Variability of reflexive eye and perceptual responses in two cerebellar patients during pitch rotations. Slow-phase eye velocity and perceived rotational velocity responses with corresponding simulated curves in two patients (patient no. 2 [left column], patient no. 7 [middle column]) and one healthy subject (right column) after the sudden stop from an earth-vertical pitch rotation. The two patients demonstrate the wide spread of reflexive and perceptual responses observed during earth-vertical pitch rotations. doi:10.1371/journal.pone.0036763.g005

constitutes a network of neurons within the brainstem and cerebellum. The fact that a plateau-like behavior, quantitatively reflected by the significant difference in gain ratios between eye and perceptual velocities, was found only in perceptual but not in eye movement responses at least allows such speculation. At this point of time, in fact, we simply can provide evidence that the same model architecture holds for reflexive eye movements and

perceptual responses. Further studies investigating perceptual responses in animals with single cell recordings will possibly shed further light on this conundrum (see [45] for a recent review).

We did not find any significant difference in the duration of reflexive eye movements and sensation in our patients compared to healthy age-matched subjects. This contrasts Bronstein et al. findings of a shortening of the vestibulo-ocular and vestibulo-perceptual responses compared to healthy controls. It is conceivable that this discrepancy might originate from subtle differences in the populations of patients, e.g. in etiology, disease duration, and region predominantly affected by cerebellar atrophy. Regarding this latter, in fact, ablation in rhesus monkeys point to a separate control of the horizontal and vertical/torsional rVOR time constants by different regions (specifically the lateral and central portions) of the nodulus and ventral uvula [23]. Moreover, as already outlined in the Introduction, studies in primates and in humans support the assumption that lesions along different neural structures of the vestibulo-cerebellum may cause somewhat opposite effects on the rVOR duration [15,17,23,26,27,28,29].

A last remark concerns the finding of a wide spread in the duration of reflexive and perceptual responses observed during earth-vertical pitch rotations in our patients (see Figure 2 and 3). Specifically, in three patients, reflexive and perceptual central velocity storage time constants were even twice the mean central time constants found in our healthy control group. Presumably, such prolonged time constant resulted from a loss of the suppressive effect of the

Table 3. Ratios of best fit gain parameters of simulated slow-phase eye velocity and perceived rotational velocity curves.

	cerebellar patients	healthy controls	p-value
<i>yaw rotations</i>			
R_{vor}	0.20±0.11	0.15±0.07	p = 0.17
R_{perc}	0.48±0.30	0.30±0.14	p = 0.07
<i>pitch rotations</i>			
R_{vor}	0.22±0.16	0.10±0.07	*p = 0.03
R_{perc}	0.45±0.26	0.35±0.18	p = 0.30

Ratios of best fit gain parameters obtained with constrained velocity-storage time constant (τ_{VSM}). Values are means \pm 1SD. R_{vor} and R_{perc} : ratio of indirect pathway gain to direct pathway gain estimated for slow-phase eye velocity and perceived rotational velocity, respectively.

doi:10.1371/journal.pone.0036763.t003

vestibulo-cerebellum on the velocity storage network, known to occur in physiological conditions [15,46,47,48]. Interestingly, moreover, motion sickness was foreground in those three patients during earth-vertical pitch rotations. Precisely how motion perception is linked to the velocity storage network is still unknown. rVOR habituation, a phenomenon producing the shortening of the time constant of the rVOR and depending on the integrity of the vestibulo-cerebellum [46], however, has been shown to decrease the susceptibility to motion sickness in humans as recently suggested in a study on healthy subjects [49]. Thus, although the exact nature and interplay between perception, the velocity storage mechanism and the vestibulo-cerebellum remains to be elucidated, our study evidences a crucial contribution of the velocity storage mechanism to perceptual control [19]. It furthermore underlines the important role of the vestibulo-cerebellum in the processing of motion

perception [49,50,51] and provides support to the discussion about the role of the cerebellum in non-motor higher cognitive, behavioral and affective functions coined by Schmahmann and Sherman (1998) as the 'cerebellar cognitive affective syndrome' [52].

Acknowledgments

The authors thank M. Penner for technical assistance.

Author Contributions

Conceived and designed the experiments: GB AP SM. Performed the experiments: AP. Analyzed the data: GB AP. Contributed reagents/materials/analysis tools: GB SR CB DS. Wrote the paper: GB AP. Model development: GB AP SR.

References

- Blanks RH, Estes MS, Markham CH (1975) Physiologic characteristics of vestibular first-order canal neurons in the cat. II. Response to constant angular acceleration. *J Neurophysiol* 38: 1250–1268.
- Buttner U, Waespe W (1981) Vestibular nerve activity in the alert monkey during vestibular and optokinetic nystagmus. *Exp Brain Res* 41: 310–315.
- Cohen B, Henn V, Raphan T, Dennett D (1981) Velocity storage, nystagmus, and visual-vestibular interactions in humans. *Ann N Y Acad Sci* 374: 421–433.
- Curthoys IS, Blanks RH, Markham CH (1977) Semicircular canal functional anatomy in cat, guinea pig and man. *Acta Otolaryngol* 83: 258–265.
- Dai M, Klein A, Cohen B, Raphan T (1999) Model-based study of the human cupular time constant. *J Vestib Res* 9: 293–301.
- Fernandez C, Goldberg JM (1971) Physiology of peripheral neurons innervating semicircular canals of the squirrel monkey. II. Response to sinusoidal stimulation and dynamics of peripheral vestibular system. *J Neurophysiol* 34: 661–675.
- Gizzi MS, Harper HW (2003) Suppression of the human vestibulo-ocular reflex by visual fixation or forced convergence in the dark, with a model interpretation. *Curr Eye Res* 26: 281–290.
- Leigh RJ, Zee DS, editors (2006) *The neurology of eye movements*. 4 ed.
- Oman CM, Marcus EN, Curthoys IS (1987) The influence of semicircular canal morphology on endolymph flow dynamics. An anatomically descriptive mathematical model. *Acta Otolaryngol* 103: 1–13.
- Raphan T, Matsuo V, Cohen B (1979) Velocity storage in the vestibulo-ocular reflex arc (VOR). *Exp Brain Res* 35: 229–248.
- Robinson DA (1977) Vestibular and optokinetic symbiosis: an example of explaining by modeling. In: Berthoz RBA, editor. *Control of Gaze by Brain Stem Neurons*: Elsevier Amsterdam. 49–58.
- Okada T, Grunfeld E, Shallo-Hoffmann J, Bronstein AM (1999) Vestibular perception of angular velocity in normal subjects and in patients with congenital nystagmus. *Brain* 122 (Pt 7): 1293–1303.
- Bertolini G, Ramat S, Laurens J, Bockisch CJ, Marti S, et al. (2010) Velocity storage contribution to vestibular self-motion perception in healthy human subjects. *J Neurophysiol* 105: 209–223.
- Sinha N, Zaher N, Shaikh AG, Lasker AG, Zee DS, et al. (2008) Perception of self motion during and after passive rotation of the body around an earth-vertical axis. *Prog Brain Res* 171: 277–281.
- Waespe W, Cohen B, Raphan T (1985) Dynamic modification of the vestibulo-ocular reflex by the nodulus and uvula. *Science* 228: 199–202.
- Angelaki DE, Hess BJ (1994) Inertial representation of angular motion in the vestibular system of rhesus monkeys. I. Vestibuloocular reflex. *J Neurophysiol* 71: 1222–1249.
- Angelaki DE, Hess BJ (1995) Inertial representation of angular motion in the vestibular system of rhesus monkeys. II. Otolith-controlled transformation that depends on an intact cerebellar nodulus. *J Neurophysiol* 73: 1729–1751.
- Cohen B, John P, Yakushin SB, Buettner-Ennever J, Raphan T (2002) The nodulus and uvula: source of cerebellar control of spatial orientation of the angular vestibulo-ocular reflex. *Ann N Y Acad Sci* 978: 28–45.
- Green AM, Angelaki DE (2003) Resolution of sensory ambiguities for gaze stabilization requires a second neural integrator. *J Neurosci* 23: 9265–9275.
- Merfeld DM, Young LR, Paige GD, Tomko DL (1993) Three dimensional eye movements of squirrel monkeys following postrotatory tilt. *J Vestib Res* 3: 123–139.
- Sheliga BM, Yakushin SB, Silvers A, Raphan T, Cohen B (1999) Control of spatial orientation of the angular vestibulo-ocular reflex by the nodulus and uvula of the vestibulocerebellum. *Ann N Y Acad Sci* 871: 94–122.
- Wearne S, Raphan T, Cohen B (1996) Nodulo-uvular control of central vestibular dynamics determines spatial orientation of the angular vestibulo-ocular reflex. *Ann N Y Acad Sci* 781: 364–384.
- Wearne S, Raphan T, Cohen B (1998) Control of spatial orientation of the angular vestibuloocular reflex by the nodulus and uvula. *J Neurophysiol* 79: 2690–2715.
- Hain TC, Zee DS, Maria BL (1988) Tilt suppression of vestibulo-ocular reflex in patients with cerebellar lesions. *Acta Otolaryngol* 105: 13–20.
- Heide W, Schrader V, Koening E, Dichgans J (1988) Impaired discharge of the eye velocity storage mechanism in patients with lesions of the vestibulo-cerebellum. *Adv Otorhinolaryngol* 41: 44–48.
- Jeong HS, Oh JY, Kim JS, Kim J, Lee AY, et al. (2007) Periodic alternating nystagmus in isolated nodular infarction. *Neurology* 68: 956–957.
- Moon IS, Kim JS, Choi KD, Kim MJ, Oh SY, et al. (2009) Isolated nodular infarction. *Stroke* 40: 487–491.
- Wiest G, Deecke L, Trattmig S, Mueller C (1999) Abolished tilt suppression of the vestibulo-ocular reflex caused by a selective uvulo-nodular lesion. *Neurology* 52: 417–419.
- Angelaki DE, Hess BJ (1995) Lesion of the nodulus and ventral uvula abolish steady-state off-vertical axis otolith response. *J Neurophysiol* 73: 1716–1720.
- Stroumann D, Zee DS, Solomon D, Lasker AG, Roberts DC (1995) Transient torsion during and after saccades. *Vision Res* 35: 3321–3334.
- Clement G, Tilikete C, Courjon JH (2008) Retention of habituation of vestibulo-ocular reflex and sensation of rotation in humans. *Exp Brain Res* 190: 307–315.
- Haustein W (1989) Considerations on Listing's Law and the primary position by means of a matrix description of eye position control. *Biol Cybern* 60: 411–420.
- Raphan T, Cohen B, Matsuo V (1977) A velocity storage mechanism responsible for optokinetic nystagmus, optokinetic after-nystagmus and vestibular nystagmus. In: Bakers R, Berthoz A, editors. *Control of gaze by brain stem neurons*. Amsterdam: Elsevier. 37–47.
- Ramat S, Bertolini G (2009) Estimating the time constants of the rVOR. A model-based study. *Ann N Y Acad Sci* 1164: 140–146.
- Galiana HL, Smith HL, Katsarkas A (1995) Comparison of linear vs. non-linear methods for analysing the vestibulo-ocular reflex (VOR). *Acta Otolaryngol* 115: 585–596.
- Schwarz G (1978) Estimating the dimension of a model. *Ann Stat* 6: 461–464.
- Hastie T, Tibshirani R, Friedman J (2001) *Model assessment and selection. The elements of statistical Learning, Data Mining, Interference and Prediction*, Springer Series in Statistics. New York: Springer. 539–548.
- Guedry FE (1974) *Psychophysics of vestibular sensation. Handbook of Sensory Physiology*: Springer-Verlag. 3–154.
- Bronstein AM, Grunfeld EA, Faldon M, Okada T (2008) Reduced self-motion perception in patients with midline cerebellar lesions. *Neuroreport* 19: 691–693.
- Buttner U, Henn V, Oswald HP (1977) Vestibular-related neuronal activity in the thalamus of the alert monkey during sinusoidal rotation in the dark. *Exp Brain Res* 30: 435–444.
- Dickman JD, Angelaki DE (2004) Dynamics of vestibular neurons during rotational motion in alert rhesus monkeys. *Exp Brain Res* 155: 91–101.
- Magnin M, Fuchs AF (1977) Discharge properties of neurons in the monkey thalamus tested with angular acceleration, eye movement and visual stimuli. *Exp Brain Res* 28: 293–299.
- Marlinski V, McCrea RA (2008) Activity of ventroposterior thalamus neurons during rotation and translation in the horizontal plane in the alert squirrel monkey. *J Neurophysiol* 99: 2533–2545.
- Meng H, May PJ, Dickman JD, Angelaki DE (2007) Vestibular signals in primate thalamus: properties and origins. *J Neurosci* 27: 13590–13602.
- Bremmer F (2011) Multisensory space: from eye-movements to self-motion. *J Physiol* 589: 815–823.
- Cohen H, Cohen B, Raphan T, Waespe W (1992) Habituation and adaptation of the vestibuloocular reflex: a model of differential control by the vestibulocerebellum. *Exp Brain Res* 90: 526–538.
- Jager J, Henn V (1981) Vestibular habituation in man and monkey during sinusoidal rotation. *Ann N Y Acad Sci* 374: 330–339.
- Solomon D, Cohen B (1994) Stimulation of the nodulus and uvula discharges velocity storage in the vestibulo-ocular reflex. *Exp Brain Res* 102: 57–68.
- Dai M, Kumin M, Raphan T, Cohen B (2003) The relation of motion sickness to the spatial-temporal properties of velocity storage. *Exp Brain Res* 151: 173–189.

50. Cohen B, Dai M, Raphan T (2003) The critical role of velocity storage in production of motion sickness. *Ann N Y Acad Sci* 1004: 359–376.
51. Green AM, Angelaki DE (2004) An integrative neural network for detecting inertial motion and head orientation. *J Neurophysiol* 92: 905–925.
52. Schmahmann JD, Sherman JC (1998) The cerebellar cognitive affective syndrome. *Brain* 121 (Pt 4): 561–579.