

Optimized Design and Experiment of a Spatially Stratified Proportional Fertilizer Application Device for Summer Corn

Zheng Zuo,[†] Jianguo Zhao,* Baozhong Yin,[†] Lixia Li,[†] Hetong Jia, Baochuan Zhang, Zhikai Ma, and Jianjun Hao



Cite This: *ACS Omega* 2022, 7, 20779–20790



Read Online

ACCESS |

Metrics & More

Article Recommendations

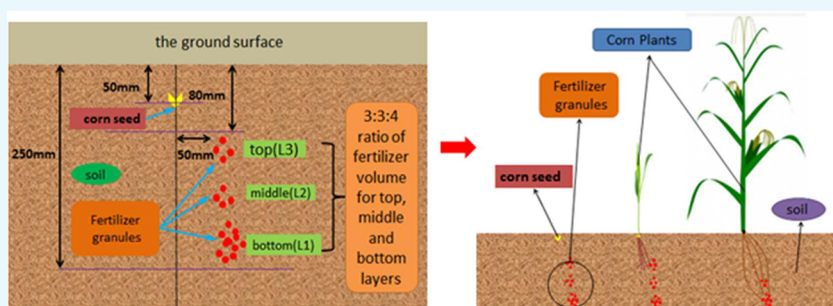

ABSTRACT: In this study, a spatially stratified proportional fertilizer application device was designed, which was mainly composed of a fertilizer equalization and stirring structure, fertilizer guide plate, and fertilizer plate. This was aimed at solving challenges presented by current fertilizer devices that include a poor layering effect due to untimely return of soil, excess nutrients in the early stages of plant growth, and insufficient quantities in the later stages. The “seed fertilizer + chasing fertilizer” is time-consuming and laborious; seed and fertilizer (without layering) are applied to the soil at once, which tends to cause too much nutrients for plants in the early stage and not enough nutrients in the later stage; and the layered fertilizer machines currently on the market have a poor layering effect due to untimely soil return. Through theoretical analysis and calculation, the structural parameters of the device were determined, and the main influencing factors of the movement law of fertilizer in the device were analyzed. Through simulating soil tank tests, the main factors affecting the effect of fertilizer spatial stratification were designed by quadratic regression orthogonal rotation combination designs. The optimal parameters including the length of the first fertilizer plate was 100 mm, the installation angle of the fertilizer plate was 80°, the spacing of the fertilizer port was 30 mm, and the uniform stirring speed was 650 r/min. The results of the bench test showed that the fertilizer granules could be uniformly stirred at the optimized stirring speed, with average values of 74.56, 76.56, and 105.19 g, which met the agronomic fertilizer application requirements, and the coefficient of variation of fertilizer application amount in each layer was less than 1%. The field test results showed that the stratified proportional fertilizer application device could achieve the stratified proportional application of fertilizer in the soil in ranges of 80.2–95.4, 150.3–180.2, and 230.3–250.4 mm for the upper, middle, and lower layers, respectively, with an error within 10 mm from the designed theoretical application depth. Compared with the conventional fertilizer application method, this fertilizer application method had a more obvious promotion effect on the 100-grain weight and yield of corn.

1. INTRODUCTION

Fertilizer plays an irreplaceable role in food production and is a key element in increasing food production.^{1–3} The International Fertilizer Industry Association (IFA) projects a 3% decrease in global fertilizer consumption at year 2022–2023 relative to the previous year due to increased prices.⁴ However, the global scale of fertilizer use still has room for growth. At the same time, the utilization rate of fertilizer varies greatly among countries; the utilization rate of fertilizer in European and American developed countries reaches 50–60%, while that in China is only about 35%.⁵ Maize is widely planted, has a long reproductive cycle and high yield, and requires more fertilizer than other cereal crops. As shown in the literature, fertilizer

applied, according to the local normal urea fertilization amount, is 6.5 kg of urea per mu for soybean and 26 kg per mu for corn, and the rest are treated according to conventional field management, without additional fertilizer application.⁶ Therefore, reasonable and precise fertilizer application is

Received: March 3, 2022

Accepted: May 23, 2022

Published: June 6, 2022



essential for growth and development of maize as well as for the protection of the ecological environment.^{7–9} At present, the main fertilizer application methods for maize in China are one-time application with seeding fertilizer,¹⁰ deep soil stratified fertilizer application,¹¹ or full-layer fertilizer application.¹² The one-time application method has low fertilizer utilization efficiency and is prone to environmental pollution.^{10,13} The stratified application method applies a certain amount of fertilizer into the soil at a certain depth in layers at one time; this method can meet the needs of maize growth cycle, and it can improve the efficiency and reduce pollution to the environment.^{14,15} Studies on stratified fertilizer application of maize in the literature^{16–18} showed that the yield of maize has a significant advantage over the quantity of fertilizer applied in one shallow or one deep application and can replace the traditional phased application in some areas.

A stratified fertilizer application device is a key component to achieve stratified application. Yang et al.⁹ designed a corn spatially stratified fertilizer application device installed behind the shovel handle of a curved deep pine shovel, and by adjusting the fertilizer application adjustment piece, the fertilizer application device could achieve 3:3:4 stratified fertilizer application in the soil space. Wansheng et al.¹⁹ designed a combined same-groove stratified fertilizer sowing opener, which could realize the application of seed, seed fertilizer, and base fertilizer into the soil in three layers on the vertical space, while the fertilizer of seed fertilizer and base fertilizer in the soil was 3:7. Junxiong et al.²⁰ designed a maize stratified orthotropic hole fertilizer precision sower, which mainly used a microcontroller-controlled intermittent mechanism at the fertilizer opening to control the fertilizer into different stratified soil layers. The fertilizer was applied in the soil layer from 7 to 23 cm below the seeds, and the fertilizer was distributed in decreasing order from the deep to shallow soil layer, in accordance with the growth pattern of maize. Jin et al.²¹ controlled the fertilizer distribution at different depths by adding fertilizer adjustment pieces in the fertilizer guide tank and determined through field tests that when the angle between the fertilizer tube and the vertical direction did not exceed 45°, the fertilizer distribution could be less at the top and more at the bottom to meet the needs of maize growth, and this fertilizer application method mainly achieved full-layer application. Jinbao et al.²² designed a layered fertilizer application device for spiral fertilizer guide groove. The fertilizer flowed down the spiral fertilizer guide groove and was discharged from outlets at different depths. By adjusting the parameters of the application port, the quantity of fertilizer applied in each layer could be adjusted. Wang et al.²³ designed a layered fertilizer application device with application tablets. By adjusting the angle of the layered fertilizer application device and the working length of the fertilizer application sheet in the middle fertilizer application port, the proportion of the quantity of fertilizer applied in each layer was adjusted. Xiaolong et al.²⁴ designed a granular fertilizer spiral combination centralized fertilizer supply device based on the mechanical and physical characteristics of granular fertilizers and the fertilizer application volume requirements. The findings of the aforementioned studies are valuable and are applied in production, but the effect of stratified fertilizer application in practice is not ideal, and it is difficult to achieve accurate proportional stratified fertilizer application under variable speeds or vibrations of machine operation.²⁵ To address the above problems, a spatially stratified proportional

fertilizer applicator was designed and the stirring structure and fertilizer guide plate in the applicator were optimized to achieve a constant proportional and stratified application volume effect. In related works on agronomic requirements, the fertilizer application depth for summer maize of generally between 80 and 250 mm can well improve the crop yield, and the fertilizer is applied to the soil in the ratio of 3:3:4 for optimal yields, which does not cause seedling burn and ensures sustained supply of nutrients at all stages of plant growth.²⁶

2. MATERIALS AND METHODS

2.1. Overall Structure and Working Principle of the Layered Fertilizer Application Device. A layered fertilizer application device was designed, and the structure diagram is shown in Figure 1. It has three fertilizer application ports at the

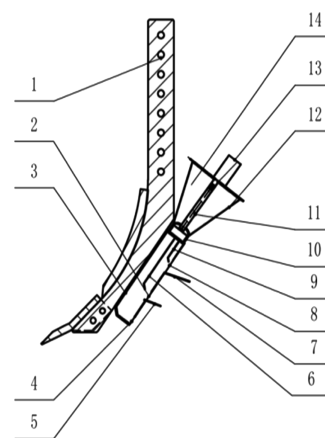

Figure 1. Structure diagram of the layered fertilizer application device.

top, middle, and bottom, mainly composed of a deep loosening shovel, fertilizer guide box, stirring structure, fertilizer guide plate, fertilizer application sheet, funnel, and motor. The stirring structure is driven by a motor, and the fallen fertilizer is stirred evenly at the fertilizer port. Then, the fertilizer flows into the preset proportional channel of the fertilizer guide plate, and under the combined action of the fertilizer guide plate and the soil return, the purpose of fixed proportion and stratification is achieved.

As shown in Figure 2, when the three fertilizer application ports on the fixed score layer applicator are working normally, the applied fertilizer is at distances of L1, L2, and L3 from the ground surface of 230–250, 150–170, and 70–100 mm, respectively, taking the mean values designed as 240, 160, and 85 mm for L1, L2, and L3, respectively.⁹

2.2. Structural Design of Key Components. 2.2.1. Stirring Structure Design. The length of the stirring shaft of the stirring structure was designed to be 160 mm, and the stirring blades were designed to be curved, mainly because the contact time between the blades and the fertilizer was longer and the stirring was more uniform during the stirring,²⁷ and since the height of the funnel was 180 mm, the length of the stirring blades was calculated to be 23 mm, and the length of the stirring structure was designed to be exactly the same as the height of the funnel, which was convenient for the fertilizer to be stirred evenly at the dispensing port. Therefore, the stirring structure is the main force structure controlling the fall of fertilizer granules. The design of the stirring structure mainly considers the strength of the shaft and the force of each blade

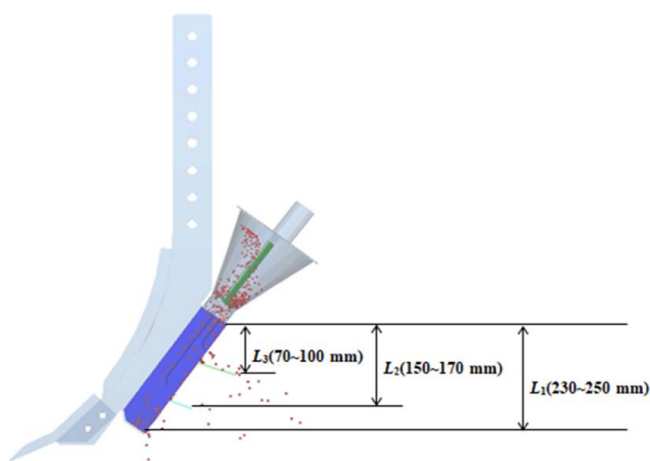

Figure 2. Effect diagram of layered fertilization.

of the stirring structure, which is mainly composed of two parts: one is the material gravity acting on the surface of the blade of the partial load G ; the other is the blade movement by the shear resistance and friction main force F . The force analysis of the blade is shown in Figure 3.

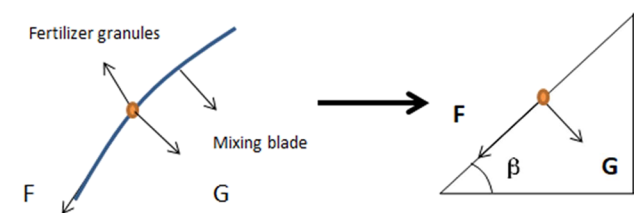

Figure 3. Force analysis of the mixing blade.

During operation, the central shaft of the mixer needs to overcome the friction moment M_f generated by the blade and material friction and the push moment M_t generated by the material gravity acting on the blade surface when pushing the material to rotate. Among them, $G = \rho gh \cos \beta$; $F = \mu \rho gh \sin \beta$. The integral method is used to calculate each moment applied to the spindle separately:²⁸

$$M_f = \int_0^l \mu \rho gh \sin \beta \cos \beta b x dx \tag{1}$$

Propulsion torque M_t

$$M_t = \int_0^l \rho gh \sin \beta \cos \beta b x dx \tag{2}$$

The comprehensive formula for each blade subject to the total moment M is

$$M = M_f + M_t = \int_0^l \rho gh (1 + \mu) \sin \beta \cos \beta b x dx = \frac{\rho gh (1 + \mu) b l^2}{2} \tag{3}$$

where ρ is the fertilizer granule density (1328 kg/m^3); g is the gravitational acceleration (9.8 N/kg); l is the blade length (m); b is the width of the central section of the blade and also the diameter of the circular blade (m); h is the height of the material on the blade (m); μ is the coefficient of friction between the material and blade, with the coefficient of dynamic friction taken as 0.01; β is the angle of the stirring blade with the horizontal plane after differentiation ($^\circ$); and x is the integral variables in the blade length direction.

From the safety aspect, the distance h between the material on the blade and the blade is 0.008 m. At this time, the device uses a circular interface. b is 0.003 m, and the length of the blade l is 0.023 m. Bringing the parameters into the equation, the moment of the blade is calculated as $M = 8.3 \times 10^{-5} \text{ N} \cdot \text{m}$.

In order to ensure a safe and reliable design, a safety factor was added, the material used was 45 steel, and the minimum diameter of the mixing shaft button turn strength was calculated as

$$\tau = \frac{\psi T}{W_T} \leq [\tau_T] \tag{4}$$

where τ_T is the allowable torsional shear stress (Mpa); ψ is the safety factor, equal to 1; τ is the torsional shear stress (Mpa); and T is the torque applied to the shaft ($\text{N} \cdot \text{mm}$). The torsional section factor of the hollow shaft is calculated as

$$W_T = \frac{\pi(D^4 - d^4)}{16D} \tag{5}$$

where W_T is the torsional section factor of the shaft (mm^3); D is the outer diameter of the stirring shaft (mm); and d is the inner diameter of the stirring shaft (mm).

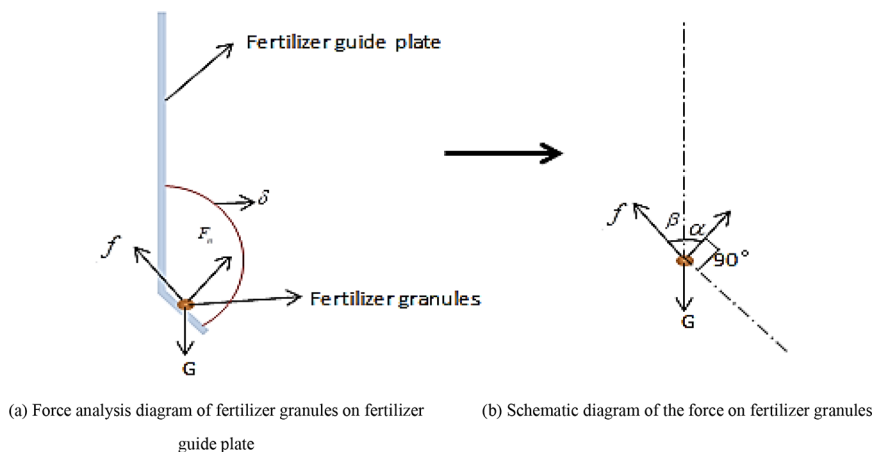

Figure 4. (a) Force analysis of fertilizer particles on the fertilizer guide plate and (b) simplified structure diagram.

The calculation yield $d \geq 10$ mm; rounding, d takes 10 mm, and D takes 16 mm.

2.2.2. Design of the Fertilizer Guide Plate. The relationship between the forces of the fertilizer granule and the fertilizer guide during the descent of the fertilizer granule at the application port is shown in Figure 4 below.

The mechanical analysis of the fertilizer granules according to the above figure leads to the following relationships (eqs 6 and 7):

$$F_n \cos \alpha + f \cos \beta = G \quad (6)$$

$$F_n \sin \alpha > f \sin \beta \quad (7)$$

Of which, $f = \mu F_n$. The derivation from eq 7 yields

$$\frac{\sin \alpha}{\sin \beta} > \frac{f}{F_n} = \frac{\mu F_n}{F_n} = \mu \quad (8)$$

where F_n is the support reaction force of the fertilizer guide plate to the fertilizer granules (N); f is the frictional force to which the fertilizer granules are subjected on the fertilizer guide plate (N); G is the gravity of the fertilizer granules (N); μ is the fertilizer granules and fertilizer guide plate friction coefficient; α is the angle between the support reaction force on the fertilizer and the fertilizer guide ($^\circ$); β is the angle between the friction and the fertilizer guide ($^\circ$); and δ is the bending angle of the fertilizer guide plate ($^\circ$).

According to eq 8, it can be derived that $\sin \alpha > \mu \sin \beta$ because $0 \leq \mu \leq 1$; in order for the equation to hold exactly, the limit value of α 45° was taken because $\alpha + \beta = 90^\circ$ and $\beta = 45^\circ$. Also, because $\beta + \delta = 180^\circ$, so the bending angle δ of the fertilizer guide plate is 135° . However, the impact of the particles falling on the fertilizer guide plate is still relatively small, so the thickness of the fertilizer guide plate is set at 1.5 mm for easy processing, and the distance between the fertilizer guide plate and the two sides of the fertilizer guide box is 0.5 mm when the fertilizer guide plate is installed.

2.2.3. Proportion Design of the Fertilizer Outlet. In order to achieve the effect of agronomic fertilizer application with a spatially stratified application ratio of 3:3:4, the area of the fertilizer distribution port is divided into 3:3:4 by using a fertilizer guide plate.

2.3. Test Conditions and Simulation Parameter Settings. The soil in the experimental area (North China Plain) is silty light loam, with 16.7 g/kg organic matter, 1.1 g/kg total nitrogen, 12.1 mg/kg $\text{NH}_4^+\text{-N}$, 31.6 mg/kg $\text{NO}_3^-\text{-N}$, 14.8 mg/kg available phosphorus, and 174.0 mg/kg available potassium. The fertilizer used in this experiment is a compound fertilizer with 15% N, 15% P_2O_5 , and 15% K_2O supplied from Stanley Fertilizer Co., Ltd.²⁹ The fertilizer belongs to sphere-like particles, in which the percentage of spherical shape is more than 90%, so the spherical particles can be used instead of fertilizer particles in the simulation.^{30,31} The material parameters set in the simulation software are shown in Table 1,³² and the contact parameters among the materials are shown in Table 2.³³

The particle plant was set up with a particle generation rate of 500 particles/s and a drop velocity of 23 cm/s. Hertz-Mindlin (no slip) was used as the contact model between particles and particles and particles and geometry. The simulation time was set to 10 s, the Rayleigh time stepping was 20%, and the data recording interval was 0.1 s.^{33–35}

2.4. Simulation Model of the Fertilization Device under Different Stirring Speeds. In order to establish the

Table 1. Material Parameters in Simulation Software

materials	density (kg/m ³)	Poisson's ratio	shear modulus (MPa)
compound fertilizer granules	1328	0.25	1.0×10^7
soil	2500	0.3	1.0×10^6
fertilizer application device (steel)	7800	0.3	7.0×10^{10}

Table 2. Contact Parameters between Materials in Simulation Software

parameters	crash recovery factor	static friction coefficient	coefficient of dynamic friction
compound fertilizer granules	0.307	0.372	0.123
fertilizer application device with compound fertilizer	0.590	0.312	0.010
soil particles	0.200	0.400	0.300
fertilizer application device and soil	0.300	0.500	0.050
compound fertilizer granules and soil	0.020	1.250	1.240

optimal stirring uniformity of the stirring structure, the three-dimensional diagram of the stirring structure was added to the simulation software, and the simulation set the stirring speed of the structure at 400, 500, 600, 700, 800, and 900 r/min. The final simulation model of the fertilizer stirring structure is shown in Figure 5.

2.5. Quadratic Regression Orthogonal Rotation Combination Design Simulation Experiment. At the same time, taking the simulation of three-layer fertilizer in the soil trough with the proportion stratified fertilizer applicator as the test index, the quadratic regression orthogonal rotation combination design simulation experiment was carried out to study the influence of various factors on stratification so as to optimize the stratified application device and working parameters. The coding of test factors is shown in Table 3. The test factors are shown in Figure 6.

2.6. Soil Simulation Model Construction. According to Jin et al.³⁴ the shape of soil particles is generally spherical, nuclear, and columnar. The smaller the size of soil particles, the longer the simulation calculation time. To improve the calculation efficiency and save time, a sphere with a diameter of 6 mm was used to represent the spherical shape, a nuclear soil particle consisted of a combination of particles with a length of 12 mm and a width of 6 mm spherical shapes, and a column shape consisted of three spheres.³⁶

A virtual soil tank with dimensions of 600 mm (length) \times 400 mm (width) \times 400 mm (height) was created in the simulation software. Soil particles were stacked in a 1:1:1 ratio of spheres, nuclei, and columns, and the soil trough stacking was completed. The effect of the simulated fertilizer application device in the soil is shown in Figure 7, from which it can be seen that the optimized fertilizer application device is significantly more effective than the non-optimized one.

A quadratic regression orthogonal rotational combination experimental design was conducted using Design-Expert, and a total of 17 sets of simulation tests were performed. The three factors were A being the length of the first fertilizer application plate, B being the installation angle of the fertilizer application plate, and C being the spacing of the fertilizer outlet, and the test protocols and results are shown in Table 4.

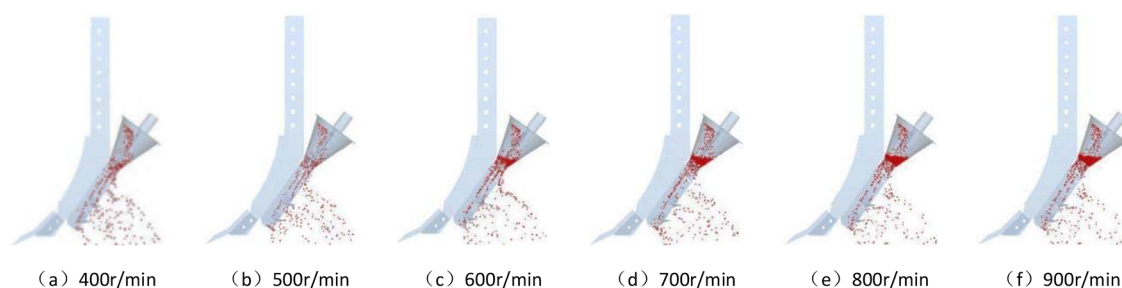

Figure 5. (a–f) Fertilizer dropping effect of the fertilization device at stirring speeds of 400–900 r/min.

Table 3. Coding of Test Factors

codes	factors		
	A (mm)	B (°)	C (mm)
−1	80	70	30
0	90	80	40
1	100	90	50

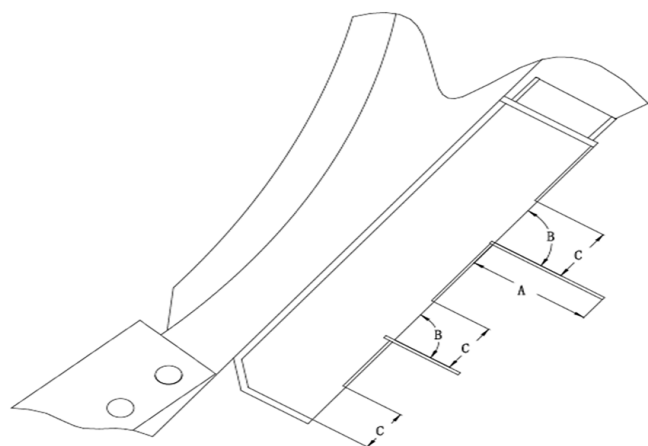
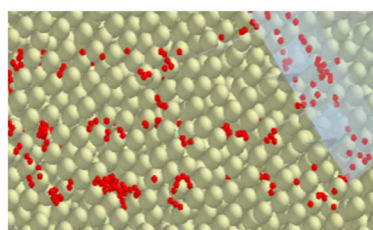
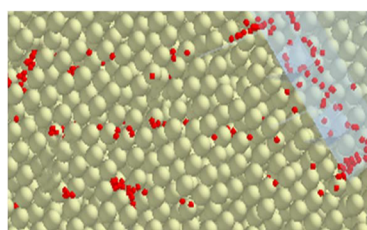

Figure 6. Schematic diagram of the factors to be optimized.

2.7. Bench Validation Test. **2.7.1. Test Conditions and Evaluation Indicators.** In order to verify the effect of static fertilization, a 3D printer was used to print out the parts of the stratified proportional fertilizer application device, and the stirring structure was made with 45 steel. After the fertilizer application device was made, the bench test was carried out. During the experiment, 1 kg of compound fertilizer was taken each time, and then the compound fertilizer was imported into the fertilizer applicator through the fertilizer inlet. After the fertilizer was dropped, the weight of the fertilizer discharged from the three fertilization outlets was collected and weighed, and the fertilizer proportion of each layer was calculated. The



(a) The effect of the model before optimization



(b) The effect after model optimization

Figure 7. Comparison of simulation effects (a) before and (b) after optimization of the fertilizer application device.

Table 4. Test Scheme and Results^a

number	A (mm)	B (°)	C (mm)	RI
1	80	70	40	2
2	100	70	40	5
3	80	90	40	1
4	100	90	40	2
5	80	80	30	3
6	100	80	30	5
7	80	80	50	1
8	100	80	50	2
9	90	70	30	5
10	90	90	30	2
11	90	70	50	2
12	90	90	50	1
13	90	80	40	3
14	90	80	40	3
15	90	80	40	3
16	90	80	40	4
17	90	80	40	3

^aThe results were 1, 2, 3, 4, and 5. The higher the value, the better the effect of stratified application.



1. Deep loosening shovel 2. Fertilizer equalization and mixing device 3. Fertilizer guide box

Figure 8. Test site.

experiment was repeated three times, and the average value was calculated, as shown in Figures 15 and 16.

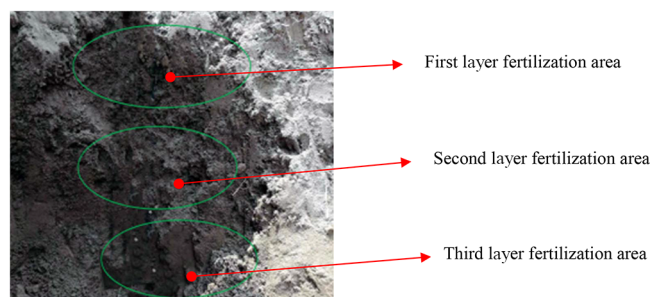

Figure 9. Effect of stratified fertilizer application.

2.8. Field Trials and Experimental Phenomena. A field experiment was conducted in Dingzhou Experimental Base of Hebei Province on June 22, 2021 to verify the effect of the spatially stratified proportional fertilizer application device. The tractor was Revo M1054-F, the test speed was 3.5 km/h, and the stirring speed of the stirring structure was 650 r/min. The machine forwarded the fertilizer application operation 200 m and, every 20 m, selected a measuring point, for a total of eight measuring points. The fertilization equipment and field test are shown in Figure 8, measuring the depth of layered fertilization and three layers of fertilizer spatial distribution, as shown in Figure 9.

2.9. Effect of Different Fertilizer Application Methods on Physical Characteristics and Yield of Maize. In the experimental field of Malan farm in Xinji City, Hebei Province, parameters such as plant height, stem diameter, dry weight, and yield at maturity of summer maize were sampled and compared in 2 years from 2020 to 2021. Mature corn samples were randomly selected from the experimental field for measurement and recording, and finally, each parameter of maize was obtained and the mean value of each parameter is presented, as shown in Table 8.

3. RESULTS AND DISCUSSION

3.1. Comparative Simulation Analysis of the Structure with and without Stirring. In order to test the role of the stirring structure in the fixed score layer fertilizer spreader, the fertilizer spreader with and without the stirring structure was simulated and compared in the simulation software. After the simulation was completed, a counter for calculating the number of fertilizer particles was set at the three outlets of the fertilizer applicator, and the results are shown in Figure 10, implying that the fertilizer applicator with the stirring structure

had an improved effect compared with the applicator without the stirring structure.

3.2. Optimal Stirring Speed Analysis of the Stirring Structure. From the simulation test in Figure 5, it can be seen that when the stirring speed was lower than 600 r/min, the stirring effect was not good, and the best agronomic effect of layered fertilizer application 3:3:4 cannot be achieved, that is, the effect of uniform stirring was not obvious; when the stirring speed was greater than 700 r/min, the fertilizer was clogged in its stirring, and the stirring speed between 600 and 700 r/min had a better fertilizing effect. In order to further study the effect of stirring speed on the uniformity of fertilizer granules, three counters were set in the software for calculating the fertilizer that came out of the fertilizer dispensing port to check whether the stirring structure could stir the fertilizer granules uniformly. The optimum stirring speed of the stirring structure was determined to be 650 r/min, the simulation of fertilizer stirring uniformity was carried out at this speed, the total simulation time was set to 16 s, and the counters counted every 4 s. The effect of the simulation is shown in Figure 11 below.

3.3. Simulation Analysis of Static Fertilization by Fertilizer Apparatus. Under the action of the stirring structure, the fertilizer flow entered the setup proportional stratified fertilizer applicator through the fertilizer guide plate; the static simulation effect is shown in Figure 12. The fertilizer volumes at the three outlets were 454, 455, and 598 granules, with a fertilizer application ratio of approximately 3:3:4.

3.4. Single-Factor Analysis of Fertilization Device Tests. As it is a direct fertilizer applicator, the path of the first layer of fertilizer application opening is short and the fertilizer at this location is most likely to fall to the bottom of the trench, while the soil return effect at the first layer of the fertilizer outlet is worse than that of the following two layers, resulting in unsatisfactory layered fertilization.³⁷ Therefore, the parameters of the first layer of the fertilizer application plate were optimized. At the same time, the installation angle of the fertilizer plate³⁸ and the spacing of the fertilizer outlet³⁹ also had an effect on the layered fertilization, and finally, the length *A*, the installation angle *B*, and the spacing *C* of the fertilizer outlet of the first layer of the fertilizer plate were used as the test factors, and a single-factor test was conducted on these three factor indicators; the effect is shown in Figure 13a.

Figure 13a shows that the static effect of the fertilizer application device was better when the length of the first layer of the fertilizer plate was gradually increased, and since the length of the second layer of the fertilizer plate was 50 mm, the

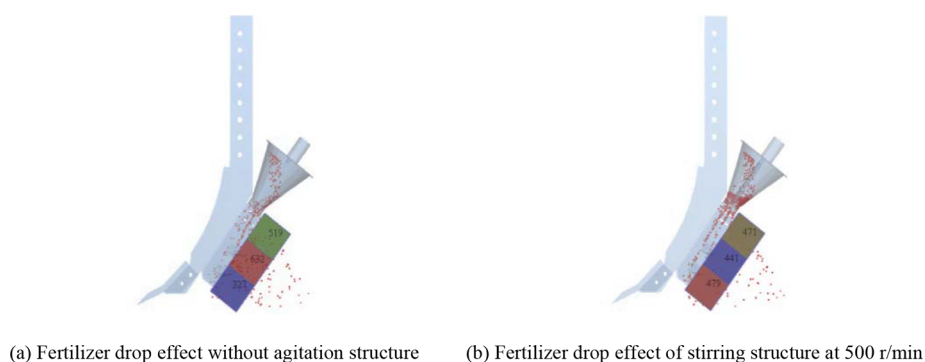

(a) Fertilizer drop effect without agitation structure

(b) Fertilizer drop effect of stirring structure at 500 r/min

Figure 10. Comparison of drop fertilizer effects between (a) no stirring structure and (b) 500 r/min stirring structure of the fertilizer application device.

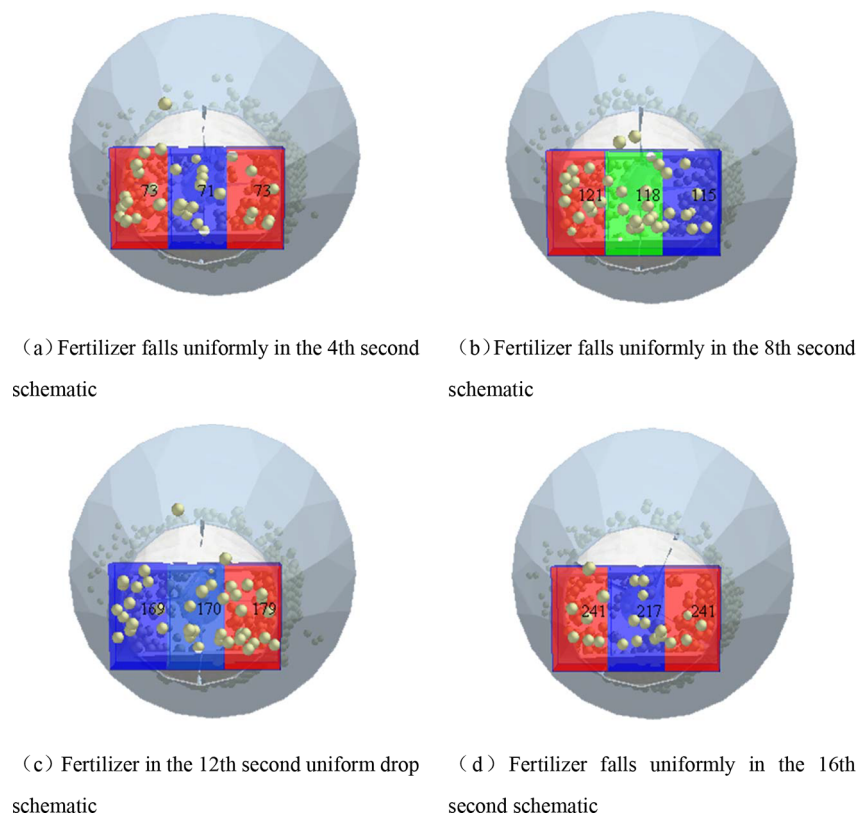

Figure 11. (a–d) Fertilizers are tested for uniformity every 4 s under the stirring speed of 650 r/min four times.

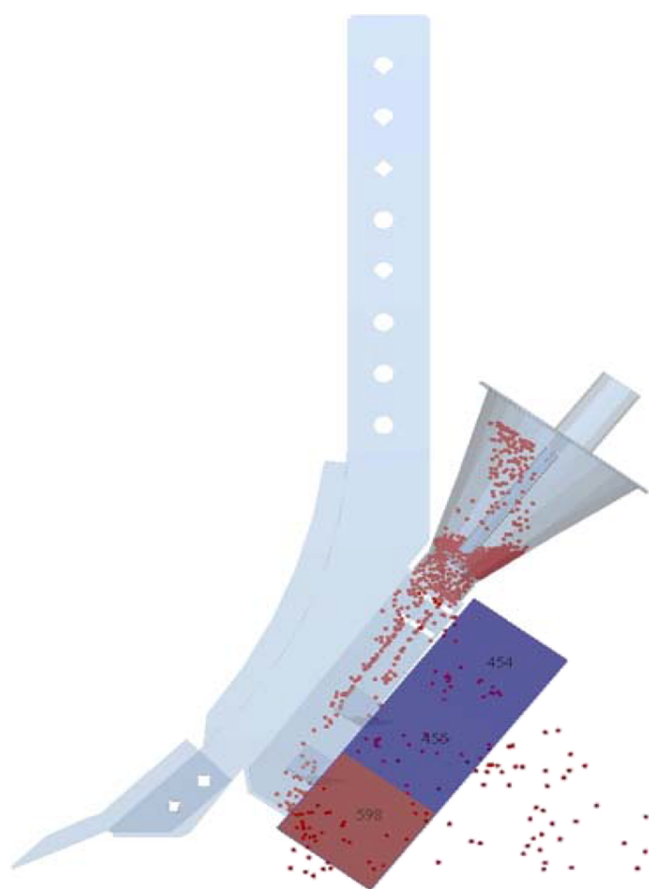

Figure 12. Effect of simulation at the optimum speed.

value range of length A of the first layer of the fertilizer plate was determined to be 80–100 mm in order to make the fertilizer application effect obvious.

As shown in Figure 13b, the fertilizer application effect was not good when the installation angle of fertilizer plate was lower than 60° , and the fertilization effect of the fertilization device became more and more obvious when the installation angle was greater than 70° , so the installation angle of the fertilizer plate took a value range of $70\text{--}90^\circ$.

From Figure 13c, it can be seen that the fertilizer application effect of the fertilization device tended to become better as the spacing of the spout increased, but when the spacing of the spout was greater than 50 mm, the fertilizer application effect of the device became worse, and the spacing C of the spacing of the fertilizer outlet was taken to be in the range of 30–50 mm, considering the phenomenon of clogging.

The level range of each test factor was determined by single-factor experiments as follows: the length of the first layer of the fertilizer application plate (A) was 80–100 mm; the fertilizer application plate installation angle (B) was $70\text{--}90^\circ$; and the outlet spacing (C) was 30–50 mm.

3.5. Test of Variance and Quadratic Regression Model Results and Analysis. Analysis of variance was performed on Table 4, and the results are presented in Table 5. Excluding insignificant items, the quadratic regression model of the error between the stratification effect of the actual fertilizer application device and the stratification effect of the target fertilizer application device is obtained as

$$Y_1 = 3.20 + 0.88A - B - 1.13C - 0.50AB + 0.50BC - 0.47B^2 \quad (9)$$

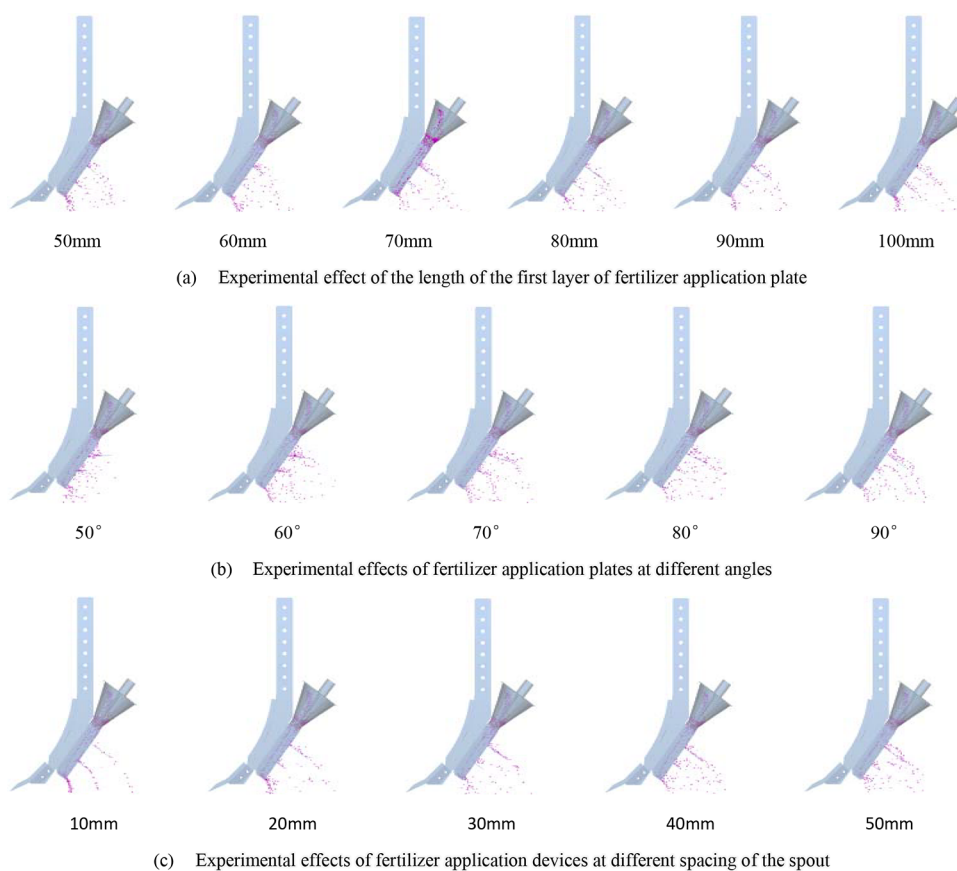

Figure 13. Single-factor simulation tests were carried out for (a) the first layer of the fertilizing board, (b) the installation angle of the fertilizer guide box, and (c) the distance between fertilizing ports.

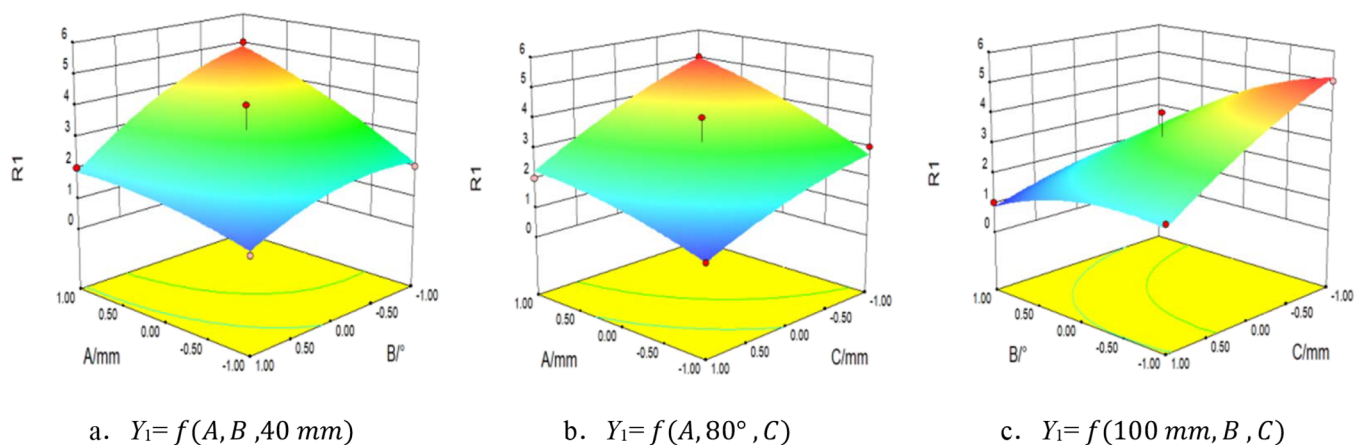

Figure 14. (a–c) Response surface of interaction factors to the error.

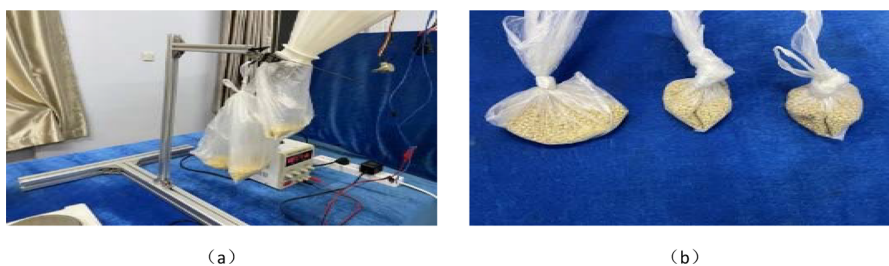

Figure 15. (a, b) Field diagram of the bench experiment.

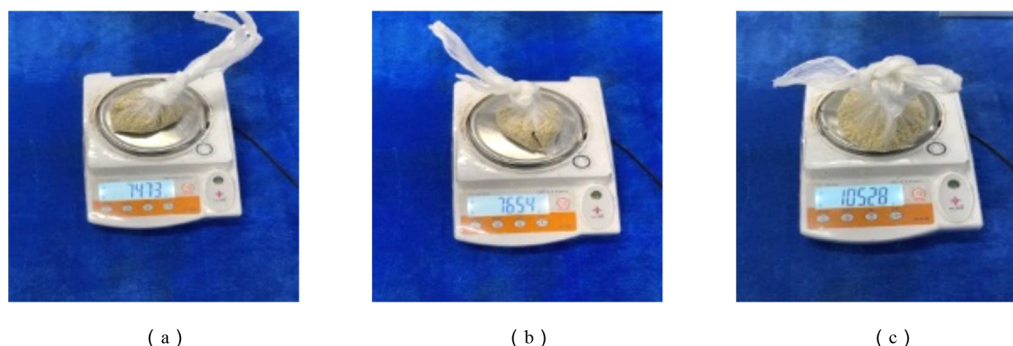

Figure 16. (a–c) Effect diagrams of fertilizer application weight verification of the three fertilizer application ports in the static test of the fertilizer application device.

Table 5. Variance Analysis Check^a

sources	sum of squares	degree of freedom	mean square	F value	P Prob > F
models	112.04	9	12.45	20.75	0.0003
A	24.50	1	24.50	40.83	0.0004
B	32.00	1	32.00	553.33	0.0002
C	40.50	1	40.50	67.50	<0.0001
AB	4.00	1	4.00	6.67	0.0364
AC	1.00	1	1.00	1.67	0.2377
BC	4.00	1	4.00	6.67	0.0364
A2	0.85	1	0.85	1.42	0.2721
B2	3.80	1	3.80	6.33	0.0400
C2	0.85	1	0.85	1.42	0.2721
residuals	4.20	7	0.60		
lack of fit	1.00	3	0.33	0.42	0.7510
pure error	3.20	4	0.80		
sum	116.24	16			

^a $P < 0.01$ was the extremely significant influence; $0.01 \leq P \leq 0.1$ was the significant effect.

According to Table 5, it can be seen that the quadratic regression model $P < 0.01$ was highly significant, and the loss of fit term $P > 0.1$ was not significant, which indicates that the fitted model can correctly reflect the relationship between each factor and the error and can better predict the test results; A, B, C, AB, BC, and B² are significant, and the rest of the terms are not significant, and according to the size of the model regression coefficient, it can be seen that the influence of each factor on the error in order from the largest to smallest is C, B, and A.

By fixing any factor at the level of 0, the response surface diagram of the interaction between the two factors on the error between the actual fertilizer application ratio and the target fertilizer application ratio was obtained, as shown in Figure 14. It can be seen from Figure 14a that the minimum error exists when the spacing of the fertilizer outlet is at the level of 0 and the length of the first fertilizer plate is 10 mm; from Figure 14b, it can be seen that the minimum error exists when the

Table 7. Measurement Results of the Fertilizer Application Position

serial no.	upper layer fertilizer (mm)	middle layer fertilizer (mm)	lower layer fertilizer (mm)
1	83.3	150.4	232.3
2	83.5	156.8	236.7
3	90.2	170.2	247.6
4	90.3	168.3	245.9
5	80.6	168.7	237.8
6	80.7	165.1	233.4
7	90.8	160.3	240.4
8	90.3	168.9	237.7
average value	86.2	163.6	239.0

installation angle of the fertilizer plate is at the level of 0 and the spacing of the outlet is 30 mm. From Figure 14c, it can be seen that the minimum error exists when the length of the first fertilizer plate is at 0 level and the installation angle of the fertilizer plate is 70° or the spacing of the fertilizer outlet is 30 mm. The optimal parameter combination obtained by using the software Optimization-Numerical module is A = 100 mm, B = 80°, and C = 30 mm. Combined with the machining practice, the optimal parameters are determined as A = 100 mm, B = 75°, and C = 30 mm.

3.6. Results and Analysis of Three Repeated Tests.

3.6.1. Test Conditions and Evaluation Indicators. Figure 16 shows the second set of experiments in a replicated experiment. Panels (a), (b), and (c) are the weight values of fertilizers discharged from the upper, middle, and lower fertilization ports of the fertilization device, which are 74.73, 76.54, and 105.28 g, respectively. After calculation, the average weights of fertilizers discharged from the upper, middle, and lower fertilization ports of the fertilization device obtained from the three repeated experiments were 74.53, 76.56, and 105.22 g, respectively.

3.6.2. Experimental Results and Analysis. **3.6.2.1. Results and Analysis of Parameters Related to Stratified Fertilization.** The results of the bench test are shown in Table 6. The

Table 6. Fertilization Ratio for Each Layer

fertilizing placement	test times and results (g)			mean value (g)	coefficient of variation (%)	relative error (%)
	1	2	3			
upper level	73.67	74.73	75.21	74.53	0.13	0.63
middle level	76.48	76.54	76.67	76.56	0.09	2.08
lower level	105.42	105.28	104.98	105.22	0.10	5.22

Table 8. Interaction of Different Fertilizer Application Methods on Growth and Yield Traits of Summer Maize at Maturity^a

year	treatment	plant height (cm)	dry matter accumulation (g/plant)	stem diameter (cm)	panicles per unit area ($\times 10^4/\text{hm}^2$)	grain number	100-grain weight (g)	yield (kg/hm^2)
2020	CK	282.6	267.5	7.82	59379.2	491.9	33.4	98564.1
	LF	279.6	281.6	7.79	58952.6	493.2	35.9	105936.2
2021	CK	274.9	273.9	7.91	58814.2	493.1	32.8	96843.6
	LF	283.6	294.1	7.88	59324.7	511.6	36.2	110562.5
year		ns	**	**	ns	**	ns	*
treatment		ns	**	ns	ns	**	**	**
year \times treatment		ns	ns	ns	*	**	*	**

^ans indicates no significant difference; * indicates that there is a significant difference at a level of 0.05; ** indicates that there is a significant difference at a level of 0.01. CK indicates conventional fertilizer application treatment; LF indicates layered fertilizer application treatment.

test was evaluated by the error between the target fertilizer application ratio and the actual fertilizer application ratio, and the coefficient of variation of fertilizer discharge stability in the upper, middle, and lower levels, and the coefficient of variation of fertilizer discharge stability was obtained from eq 10.

$$CV = \left[\frac{\sqrt{\frac{1}{N-1} \sum_{i=1}^N \left(x_i - \frac{\sum_{i=1}^N x_i}{N} \right)^2}}{\frac{\sum_{i=1}^N x_i}{N}} \right] \times 100\% \quad (10)$$

where N is the number of tests, x_i is the amount of fertilizer discharged (g), and CV is the coefficient of variation of fertilizer discharge stability (%).

It can be seen from Table 6 that the ratio of the average fertilization amount of the upper, middle, and lower layers of the fertilization device is 74.53 g:76.56 g:105.22 g, which can meet the agronomic requirements of 3:3:4, the coefficient of variation is within 1%, and the relative error is within 6%. In three repeated experiments, the lowest fertilization amount was 28.83% of the total fertilization amount and the highest fertilization amount was 29.28% of the total fertilization amount. The coefficient of variation of the fertilization amount of the upper and lower layers was larger, which was 0.04%, and the coefficient of variation of the upper and middle layers was smaller, which was 0.03%. The analysis shows that the main reason is that the fertilizer particles collide with the funnel under the rotation of the stirring structure, and the movement trajectory of the fertilizer particles changes obviously, which has a great influence on the amount of fertilizer applied to the upper layer.

3.7. Analysis of Field Test Results of the Fertilizer Application Device. It was established that the fertilizer discharged from the upper discharge port of the spatial layered fertilizer application device was mainly distributed between 80.6 and 90.8 mm from the ground surface, the fertilizer discharged from the middle discharge port was mainly distributed between 150.4 and 170.2 mm, and the fertilizer discharged from the lower discharge port was mainly distributed between 232.2 and 247.6 mm, which was within 10 mm from the designed theoretical fertilizer application depth (85, 160, and 240 mm). The difference was within 10 mm. The distribution of fertilizer in each layer showed that there was more fertilizer in the lower layer and less in the upper and middle layers, which achieved the expected effect (Table 7).

3.8. Analysis of Different Fertilizer Application Methods on Physical Characters and Yield of Maize.

From the parameter comparison in Table 8, it can be seen that under the conventional fertilizer application treatment and the layered fertilizer application treatment, the maize plant heights in 2020 were 282.6 and 279.6 cm, respectively, and the maize plant heights in 2021 were 274.9 and 283.6 cm, respectively. The diameters of corn stems in 2020 were 7.82 and 7.79 cm, respectively, and the diameters of corn stems in 2021 were 7.91 and 7.88 cm, respectively. From the maize plant height and stalk diameter data for the past 2 years, it can be seen that the data measured for maize plant height and stalk diameter was almost the same for both the stratified and conventional fertilizer application treatments, so there was no significance between the stratified and conventional fertilizer application treatments. Therefore, the stratified fertilizer application treatment could replace the conventional fertilizer application treatment, and the same can be applied to the number of panicles per unit area. However, the dry matter accumulation, grain number, 100-grain weight, and yield of maize in the stratified fertilizer application treatment were all better than those in the conventional fertilizer application treatment; especially in 2020 and 2021, the 100-grain weight and yield of maize in the stratified fertilizer application were 2.5 g, 3.4 g, 7372.1 kg/hm^2 , and 13718.9 kg/hm^2 higher than those in the conventional fertilizer application treatment, respectively. Therefore, the stratified fertilizer application treatment has a promoting effect on the growth of summer maize compared with the conventional fertilizer application treatment.

4. CONCLUSIONS

(1) A deep pine space layered proportional fertilizer application device was designed. It mainly consisted of an agitation structure, fertilizer guide sheet, and fertilizer application sheet. The designed stirring shaft diameter was 16 mm, and the bending angle of the fertilizer guide sheet was 135° . When the stirring speed of the stirring structure was 650 r/min, the fertilizer stirring uniformity was better and the agronomic requirement of 3:3:4 fertilizer application ratio for the upper, middle, and lower layers could be met.

(2) The quadratic regression orthogonal rotational combination design was used to optimize the design of the layered fertilizer application structure parameters, and a better layered fertilizer application effect was achieved when the length of the first layer of the fertilizer application plate was 100 mm, the spacing of the fertilizer application outlet was 30 mm, and the installation angle of the fertilizer application plate was 80° .

(3) The bench experiment showed that the errors of fertilizer application amount of each layer were 0.13, 0.09, and 0.1%, respectively, compared with the simulation results, and the coefficient of variation was not more than 1%. The field test showed that the error of fertilizer distribution depth in the soil of each layer was within 10 mm compared with the theoretical design, which met the design requirements.

(4) The layered fertilizer application device design had excellent promotion effects on various parameters of summer corn growth and maturity compared to the traditional fertilizer application method, such as an increase of 2–3 g in 100-grain weight and an increase of 1000–3000 kg/hm² in yield.

AUTHOR INFORMATION

Corresponding Author

Jianguo Zhao – College of Mechanical and Electrical Engineering, Agricultural University of Hebei, 071001 Baoding, China; Email: zjg790710@126.com

Authors

Zheng Zuo – College of Mechanical and Electrical Engineering, Agricultural University of Hebei, 071001 Baoding, China; orcid.org/0000-0002-2364-156X

Baozhong Yin – College of Plant Protection, Agricultural University of Hebei, 071001 Baoding, China

Lixia Li – Institute of Plant Nutrition, Resources and Environment, Beijing Academy of Agriculture and Forestry Sciences, 00097 Beijing, China; orcid.org/0000-0002-5202-0295

Hetong Jia – College of Mechanical and Electrical Engineering, Agricultural University of Hebei, 071001 Baoding, China

Baochuan Zhang – College of Mechanical and Electrical Engineering, Agricultural University of Hebei, 071001 Baoding, China

Zhikai Ma – College of Mechanical and Electrical Engineering, Agricultural University of Hebei, 071001 Baoding, China

Jianjun Hao – College of Mechanical and Electrical Engineering, Agricultural University of Hebei, 071001 Baoding, China

Complete contact information is available at: <https://pubs.acs.org/10.1021/acsomega.2c01273>

Author Contributions

[†]Z.Z., B.Y., and L.L. are the co-first authors.

Notes

The authors declare no competing financial interest.

ACKNOWLEDGMENTS

Thanks to Mechanical and Electrical Engineering College of Hebei Agricultural University for providing the experimental site. Thanks to the Hebei Provincial Key R&D Program (20326407D) for funding all authors of this project.

REFERENCES

- (1) Mutlu, A. The effect of organic fertilizers on grain yield and some yield components of barley (*Hordeum vulgare* L.). *Fresenius Environ. Bull.* **2021**, *29*, 10840–10846.
- (2) Drazic, M.; Gligorevic, K.; Pajic, M.; Zlatanovic, I.; Spalevic, V.; Sestras, P.; Skataric, G.; Dudic, B. The influence of the application technique and amount of liquid starter fertilizer on corn yield. *Agriculture* **2020**, *10*, 347.

(3) Sarkadi, L. S. Effects of Fertilizer on Food Supply. M./Chemistry's Role in Food Production and Sustainability: Past and Present. *J. Am. Chem. Soc.* **2019**, *129*–145.

(4) There will be a shortage of global fertilizer supply. EB/OL. 2022-02-15. <http://epaper.nfncb.cn/nfnc/content/20220215/Articel08002MT.htm>.

(5) What is the root cause of low fertilizer utilization rate? EB/OL. 2021-10-15. <https://wenku.baidu.com/view/52566ae72fc58bd63186bceb19e8b8f67c1cef33.html>

(6) Qin, Y. Effects of biochar application on soil physicochemical properties and microbial diversity of black soil in Northeast China. *D. Chang Chun: University of Chinese Academy of Sciences* **2017** (in Chinese with English abstract).

(7) Corrêa, J. C.; Grohskopf, M. A.; Rebellatto, A.; Rigo, A. Z.; Coldebella, A. Fertilization of high-yield corn with poultry litter based on nitrogen doses. *J. PESQUI AGROPECU BRAS.* **2018**, *53*, 342–350.

(8) Zhao, J.; Yang, X.; Dai, S.; Lv, S.; Wang, J. Increased utilization of lengthening growing season and warming temperatures by adjusting sowing dates and cultivar selection for spring maize in Northeast China. *Eur. J. Agron.* **2015**, *67*, 12–19.

(9) Yang, Q.; Xingyuan, H.; Wang, Q.; Hongwen, L.; Wang, Y.; Wang, L. Structure optimization and experiment of corn layered fertilization device. *Trans. Chin. Soc. Agric. Mach.* **2020**, *51*, 175–185 (in Chinese with English abstract).

(10) Wu, D.; Xu, X.; Chen, Y.; Shao, H.; Sokolowski, E.; Mi, G. Effect of different drip fertigation methods on maize yield, nutrient and water productivity in two-soils in Northeast China. *Agric. Water Manage.* **2019**, *213*, 200–211.

(11) Wang, Y.; Liang, Z.; Tao, C.; Dongxing, Z.; Zhe, Q.; Yang, L. Design and experiment of layered fertilization device for corn. *Trans. Chin. Soc. Agric. Mach.* **2016**, *47*, 163–169.

(12) Lijing, L.; Ma, C.; Zhongjun, L. Simulation and experiment of maize deep-soiling full-layer fertilizer shovel operation based on EDEM. *Trans. Chin. Soc. Agric. Mach.* **2021**, *12*, 1–12 (in Chinese with English abstract).

(13) Dongxing, Z. Technology and Equipment of Corn Whole-process Mechanization Production. *M. Beijing: China Agricultural University Press* **2014**.

(14) Kleinman, P. J.; Sharpley, A. N.; Withers, P. J.; Bergström, L.; Johnson, L. T.; Doody, D. G. Implementing agricultural phosphorus science and management to combat eutrophication. *J. Ambio* **2015**, *44*, 297–310.

(15) Wang, Y.; Liang, Z.; Zhang, D.; Cui, T.; Shi, S.; Li, K.; Yang, L. Calibration method of contact characteristic parameters for corn seeds based on EDEM. *Trans. Chin. Soc. Agric. Eng.* **2016**, *47*, 163–169 (in Chinese with English abstract).

(16) Changming, Z.; Yuannong, L.; Pengpeng, C. Effects of single application of fertilizer on yield and nitrogen utilization of mulching summer maize. *Trans. Chin. Soc. Agric. Mach.* **2020**, *51*, 336–344 (in Chinese with English abstract).

(17) Zhiwei, W.; Yinping, Z.; Peisong, D.; Huailong, D. Design and experiment on wheat precision no-tillage planter with subsoiling layered fertilization and wide seedling. *J. Agri. Mech. Res.* **2018**, *40*, 102–106.

(18) Li, Q.; Ming, X.; Jiang, W. Separated Amount and Layered Fertilization Device for Seeders: Design and Experiment. *Des. Eng.* **2020**, *512*–532.

(19) Wansheng, Y.; Shaoping, X.; Ruixiang, Z.; Shuwu, L.; Huilan, X. Development of combined layered fertilizing-seeding ditcher. *Nat. Sci. Ed.* **2008**, *36*, 223–228 (in Chinese with English abstract).

(20) Junxiong, Z.; Huameng, L.; Gao, J.; Lin, Z.; Ying, C. Simulation and test of corn layer alignment position hole fertilization seeder based on SPH. *Trans. Chin. Soc. Agric. Mach.* **2018**, *49*, 66–72 (in Chinese with English abstract).

(21) Jin, Z.; Jinguo, Z. The design of the key components of precise planter with subsoil and whole layer fertilization. *J. Chin. Agri. Mech.* **2012**, *90*, 83–85 (in Chinese with English abstract).

- (22) Jinbao, L.; Yan, Z.; Zheng, X.; Zhiqiang, R. Design and experiment of 2FQ-5 multilayer fertilizer applicator. *J. Gansu Agric. Univ.* **2017**, *52*, 140–147 (in Chinese with English abstract).
- (23) Wang, Y.; Liang, Z.; Tao, C.; Dongxing, Z.; Zhe, Q.; Yang, L. Structural Design and Experiment of Maize Layered Fertilizer. *Trans. Chin. Soc. Agric. Mach.* **2016**, *47*, 163–169 (in Chinese with English abstract).
- (24) Xiaolong, L.; Mengliang, L.; Lihua, Z.; Wanjun, R. Design and experiment of horizontal air-fed spiral combination adjustable quantitative fertilizer supply device for granular fertilizer. *Trans. Chin. Soc. Agric. Eng.* **2018**, *34*, 9–18 (in Chinese with English abstract).
- (25) Xiaofei, A.; Xiaoou, W.; Weiqiang, F.; Xueli, W.; Guangwei, W.; Liwei, L. Design and experiment of fertilizer amount control algorithm in four factors variable rate fertilization system. *Trans. Chin. Soc. Agric. Mach.* **2018**, *49*, 149–154 (in Chinese with English abstract).
- (26) Ma, Y.; Wu, M.; Xiaoming, L.; Yunhong, L.; Shiqing, Z.; Wang, Y.; Kunyan, S.; Zhengping, P. Responses of root activity, nutrient uptake and yield of summer maize to different fertilization methods. *Soil Fert. Sci. China.* **2020**, *5*, 95–100 (in Chinese with English abstract).
- (27) Youwei, X.; Fuchun, L.; Enyan, L.; Xianquan, L. Simulation of high concentration filling slurry mixing based on DEM-SPH coupling. *J. Min. Res. Dev.* **2022**, *42*, 162–167 (in Chinese with English abstract).
- (28) Jinqiang, Z. Design and performance study of silo-type aerobic compost reactor. *D. Nanchang: Jiangxi Agricultural University* **2020**, *1*.
- (29) Xiaoxiao, S. H. U.; Jie, M. E. N.; Yang, M. A.; Cheng, X. U. E.; Zhengping, P. E. N. G.; Guangyu, L. E. I. Regulatory effect of nitrogen reduction with organic matter application on soil nitrogen leaching. *J SOIL WATER CONSERV.* **2019**, *33*, 186–191. (in Chinese with English abstract)
- (30) Liu, J. S.; Gao, C. Q.; Nie, Y. J.; Yang, B.; Ge, R. Y.; Xu, Z. H. Numerical simulation of Fertilizer Shunt-Plate with uniformity based on EDEM software. *J. COMPUT ELECTRON AGR.* **2020**, *178*, 105737.
- (31) Bangura, K.; Gong, H.; Deng, R.; Tao, M.; Liu, C.; Cai, Y.; Liu, Y.; Liao, K.; Liu, J.; Qi, L. Simulation analysis of fertilizer discharge process using the Discrete Element Method (DEM). *J. PloS one* **2020**, *15*, No. e0235872.
- (32) Cailing, L. I. U.; Dan, W. E. I.; Jiannong, S. O. N. G.; Yanni, L. I.; Xin, D. U.; Fuyin, Z. H. A. N. G. Systematic study on boundary parameters of Discrete Element Simulation of granular fertilizer. *Trans. Chin. Soc. Agric. Mach.* **2018**, *49*, 82–89.
- (33) Hao, L. V. A new kind of method for the optimized design of outer groove-wheel fertilizer apparatuses. *D. Ji Lin: Jilin university* **2014** (in Chinese with English abstract).
- (34) Jin, Y.; Qinhua, L.; Xuemei, L.; Pain, Z.; Xiaohui, Z. Granular multi-flows fertilization process simulation and tube structure optimization in nutrient proportion of variable rate fertilization. *Trans. Chin. Soc. Agric. Mach.* **2014**, *45*, 81–87 (in Chinese with English abstract).
- (35) Ding, S.; Bai, L.; Yao, Y.; Yue, B.; Fu, Z.; Zheng, Z.; Huang, Y. Discrete element modelling (DEM) of fertilizer dual-banding with adjustable rates. *J. COMPUT ELECTRON AGR.* **2018**, *152*, 32–39.
- (36) Jinbao, L.; Zhihui, T.; Zheng, X.; Yang, H.; Luyun, Z.; Xiangjin, M.; He, X. Design and experiment of deep fertilizing shovel for furrow and layering. *J. J. Gansu Agric. Univ.* **2021**, *56*, 169–176. 186 (in Chinese with English abstract)
- (37) Lijing, L.; Ma, C.; Zhongjun, L. Optimization and Experiment of operation parameters of full-layer fertilizing shovel for zonal deep pine based on EDEM. *Trans. Chin. Soc. Agric. Mach.* **2021**, *52*, 74–83 (in Chinese with English abstract).
- (38) Yang, Q.; Wang, Q.; Hongwen, L.; He, J.; Lu, C.; Yu, C.; Shangyi, L.; Wang, Y. Development of stratified fertilizer rate adjustment device for pneumatic variable fertilizer discharge system. *Trans. Chin. Soc. Agric. Eng.* **2020**, *36*, 1–10 (in Chinese with English abstract).
- (39) Jiajun, Z. Design and experiment of trenching and fertilizing device for organic fertilizer in dwarf orchard. *D. Yanglin: Northwest A&F University* **2020** (in Chinese with English abstract).