



Transfer and Expression of Native Human Insulin-Like Growth Factor-1 in Tobacco Chloroplasts

Mohammad Ahmadabadi*

Department of Biotechnology, Faculty of Agriculture, Azarbaijan Shahid Madani University
km 35 Tabriz-Maraqeh Road, Tabriz, Iran

*Corresponding author: Mohammad Ahmadabadi, Department of Biotechnology, Faculty of Agriculture, Azarbaijan Shahid Madani University km 35 Tabriz-Maraqeh Road, Tabriz, Iran, Tel/Fax: +98-4124327572, E-mail: m.ahmadabadi@azaruniv.ac.ir

Background: Insulin-like growth factor-1 (IGF-1), in addition to having insulin-like effects, has boosting effects on all cells in human body. Most of the recombinant IGF-1 required for patients suffering from its deficiency is currently produced by bacterial and yeast systems. Plant systems, especially chloroplasts, have many benefits for producing human blood proteins. Production costs are low in these systems, and their side effects are less than other systems.

Objectives: In this study, the transfer and expression of mature IGF-1 protein cDNA in tobacco chloroplasts under the control of strong plastid transcription and translation elements was evaluated.

Materials and Methods: The biolistic transformation method was used to transfer the *IGF-1* gene cloned into the pRB94-IGF1 chloroplast vector. Homoplasmic transplastomic plants were produced through four selection rounds on the selective medium. Transfer of foreign genes to chloroplast genome was confirmed by PCR, Southern blotting and seed progeny test. RT-PCR and SDS-PAGE methods were used to evaluate the expression of *IGF-1* gene in transgenic line.

Results: A truly transformed line was identified from selected seedlings by PCR method. The seed progeny test of 4th-regeneration-round transgenic plants of this line showed maternal inheritance and homoplasmic level for the selectable marker gene, which confirms the transfer and expression of the marker gene in the chloroplast genome. The Southern blot test also confirmed the transfer of the *IGF-1* gene into the chloroplast genome. RT-PCR test showed that *IGF-1* gene transcription is performed correctly in transgenic plants. Finally, accumulation of IGF-1 protein in transgenic plants was detected by SDS-PAGE.

Conclusions: Successful transfer and expression of the native human *IGF-1* gene in tobacco chloroplast genome is reported.

Keywords: Chloroplasts, Human protein expression, Insulin-like growth factor, Plant bioreactor system, Recombinant protein

1. Background

Insulin-Like Growth Factor 1 (IGF-1) stimulates the body's systemic growth and has growth-promoting effects on almost all cells in the body, especially the liver, kidneys, skeletal muscle, bones, nerves, skin, and lung cells. Also, this factor, with its ability to bind to insulin receptors, has insulin-like effects and is involved in regulating DNA replication (1). IGF-1 is one of the most potent natural activators of the Protein Kinase B (PKB) signaling pathway, which is a stimulator of cell growth and proliferation and an inhibitor of

programmed cell death (2, 3). Because of the important functions of IGF-1 in the body, people who suffer from IGF-1 deficiency, often experience harmful side effects (4), which in its most severe form leads to a Laron-like dwarf phenotype (5). The efficacy and safety of IGF-1 therapy in these patients have been evaluated for more than two decades. There have also been reports in the past few years of the benefits of treating short stature in children with recombinant IGF-1 (6). For example, in Polish patients, treatment with recombinant IGF-1 had a clear effective and safe effect on patients' height,

especially in the first year of treatment (7). Currently, most recombinant IGF-1 is produced using *E. coli* (8) or yeast (9), which are expensive. In addition, the formation of inclusion bodies in *E. coli* or the variable biological activity of IGF-1 produced in yeast is another disadvantage of current production systems. Plant systems have many advantages, including the low cost of large-scale plant production, the ability to easily store or transport, and the presence of natural organs for protein storage, suitable for the production of large-scale recombinant proteins on an industrial scale (10). The cost of plant-based recombinant proteins can be 10 to 50 times lower than the production of similar proteins in bacterial or yeast systems (11). However, a major drawback to the expression of human blood proteins through the nuclear genome is their low expression level, which is generally less than 1% of total soluble protein (12). For example, the expression level of IGF-1 in transgenic rice and tobacco, after optimizing codons for expression in plants and using optimal regulatory sequences, has been reported in the range of 0.002 - 0.011% of total soluble protein (13). Although progress has been made in recent years in increasing the expression of foreign genes (10, 14), there are not many examples of high expression levels of human blood protein using nuclear genome transformation. In addition, the expression of foreign genes in the nuclear genome faces other challenges, such as the possibility of transgene silencing, the transgene position effect, and the existence of epigenetic effects (15). Over the past few years, with the transfer and expression of foreign genes in the chloroplast organelle, in addition to solving these problems, the expression of foreign protein has been reported to be more than 46% of leaf total soluble protein (16). Another important benefit of expressing foreign genes through the chloroplast genome is transgene containment in transgenic plants due to maternal inheritance of the chloroplast genome (17, 18). In addition, therapeutic proteins expressed in transgenic chloroplasts have been demonstrated to be fully functional with proper post-translational modifications (19). Based on these advantages, several human blood proteins, including somatotropin (20), interferon gamma (21), interferon alpha (22), and insulin (23), have been expressed in Chloroplasts and their proper function has also been confirmed. In 2009, Henry Daniell and coworkers, examined the expression of native and synthetic versions of human IGF-1 in

bacterial hosts (*E. coli*) and tobacco chloroplasts and showed that unlike the synthetic version with modified codon usage, the native version is not able to express in *E. coli* (24). The expression of recombinant protein was estimated to be about 11.3% of total protein, which could be increased up to 32% by optimizing plant growth conditions. Interestingly, unlike *E. coli*, the native and synthetic versions did not show much difference in chloroplast expression, indicating a high insensitivity of the tobacco chloroplast expression system to codon usage.

2. Objectives

In this study, we examined the expression of native human IGF-1 in tobacco chloroplasts. Compared to the study done by Daniell *et al.* (2009), in this study, the position of foreign gene insertion in the tobacco chloroplast genome, as well as factors controlling *IGF-1* gene expression were different, which will be discussed in the following.

3. Materials and Methods

3.1. Plastid-Specific Transformation Vector

The pRB94-IGF1 chloroplast vector (25) with a size of 7581 bp, which is a derivative of the pRB94 vector (Kindly provided by Prof. Ralph Bock, Max-Planck Institute for Molecular Plant Physiology, Golm, Germany) and carries mature *IGF-1* cDNA with a size of 321 bp (**Fig. 1A**). In this vector, the *aadA* selectable marker gene is driven by the Prn promoter (The tobacco plastid rRNA operon promoter) and the TpsbA terminator. The *IGF-1* gene is also under the control of the Prn promoter fused with the 5' UTR of gene 10 from *E. coli* phage T7 and the downstream box (T7g10-DB), which have significant effects on RNA stability and translation efficiency (26), and the TrbcL terminator from tobacco. In addition, the Shine Dalgarno (SD) sequence, which is necessary to start translation in prokaryotic systems, was added just before the start codon. Transgene cassettes are cloned in an intergenic region between the *trnG* and *trnFM* genes of the tobacco chloroplast genome. The left flank (LF) region contains the *trnG* and *psbZ* sequences, and the right flank (RF) region contains the *trnFM*, *rps14*, and 3' part of the *psaB* gene (**Fig. 1**). The expected physical map for the chloroplast genome (transplastome) after receiving the foreign genes is shown in **Figure 1B**.

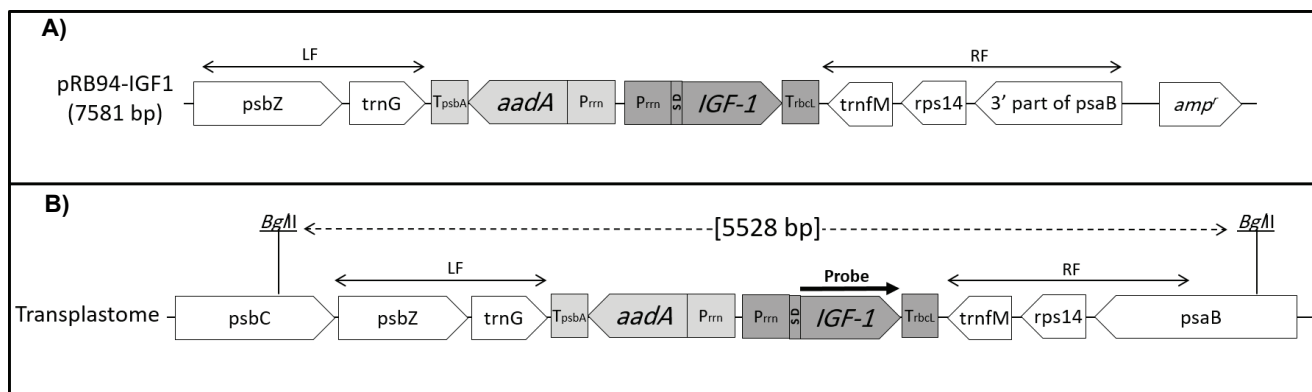

Figure 1. Schematic map of chloroplast vector pRB94-IGF1 **A)**, and the status of transgenic tobacco plastid genome (transplastome) after insertion of foreign genes in chloroplast genome **B)**. The left flank (LF) and right flank area which are used for targeting transgenes into plastid genome by homologous recombination, are indicated. SD: Shine Dalgarno.

3.2. Transfer of Recombinant Vector to Tobacco Chloroplasts

BioRad PDS-1000/He™ System gene gun was used to transfer recombinant plasmid to young leaf cells of tobacco plants (*Nicotiana tabacum* Petit Havana). In summary, young leaves were first cut from 3-week-old sterile tobacco seedlings and were placed on RMOP medium from their adaxial side (**Fig. 2A**). The abaxial side of the leaves were then bombarded with 0.6 μ m gold particles coated with the pRB94-IGF1 vector with 1100 psi pressure. The leaves were then cut into 0.5 cm² pieces and transferred to RMOP regeneration medium (27) containing 500 mg.L⁻¹ spectinomycin. The cultures were placed in a growth chamber with a light cycle of 16 h light (25 °C) and 8 h dark (22 °C). After regeneration of potential transgenic plants and their initial confirmation using PCR, to obtain homoplasmic level, four rounds of selection and regeneration of leaf fragments from regenerated plants were performed. Last generation plants were used for further studies.

3.3. Examination of IGF-1 Transcripts by RT-PCR

RT-PCR was used to evaluate the *IGF-1* expression in transgenic plants at the transcriptional level. In summary, the total RNA was extracted from leaf tissues using the RNXTM-Plus extraction kit (SINACLON, Iran) according to the manufacturer's instructions. The samples were then treated with RNase-free DNase I to eliminate possible genomic DNA contaminations. To prepare cDNA, after testing genomic DNA

elimination by PCR on RNA samples, 14 μ L of reaction solution containing 5 μ g of the extracted RNA, 10 pM poly T oligonucleotide and 10 mM dNTP mixture, was placed at 65 °C for five min, followed by transferring on ice immediately. After one minute, 4 μ L of 5 \times reverse-transcription buffer, 1 μ L of 0.1 M DTT, 1 μ L of 50 mM MgCl₂ and 0.5 μ L of Super Script III reverse transcriptase (5 U. μ L⁻¹) were added to the reaction solution. Synthesis of the first strand of cDNA was carried out for 1 hour at 50 °C. A pair of *IGF-1* gene specific primers (5'-AAA CAT ATG GGA CCG GAG ACG CTC TG-3' and 5'-AAA TCT AGA CTA CAT CCT GTA GTT CTT GTT TCC T-3') were used to amplify transgene cDNA copies of 336 bp in size. PCR program included a 4-minute stage at 95 °C; 30 cycles, each consisting of 45 s at 95 °C, 45 s at 55 °C and 90 s at 72 °C; and a final extension at 72 °C for 10 min.

3.4. Investigation of the Physical Presence of Foreign Genes in the Chloroplast Genome Using Southern Blot

In addition to PCR, Southern blot was used to evaluate the physical presence of foreign genes in transgenic plants. To ensure the transfer of *IGF-1* to the chloroplast genome, the plastid genome of transgenic plants in the region outside the Left flank and Right flank sequences was cut using the *Bgl*III restriction enzyme, in which case a 5528 bp fragment of the genomes of transgenic chloroplasts will be isolated (**Fig. 1B**). In summary, after extraction of whole DNA by cetyltrimethylammonium bromide (CTAB) method (28), about 10 μ g of it was

cleaved by *Bgl*III, separated by gel electrophoresis in 1% agarose gel, and transferred onto Hybond nylon membranes (Amersham, Buckinghamshire, UK) by capillary blotting using standard protocols.

The Biotin DecaLabel DNA Labeling Kit (Thermo Fisher Scientific™) was used to hybridize and identify DNA fragments containing foreign genes based on the manufacturer's description. The complete *IGF-1* sequence, which was isolated from the vector by enzymatic digestion, was used as a probe (**Fig. 1B**).

3.5. Progeny Test to Evaluate the Successful Transfer of the Foreign Genes into the Chloroplast Genome

To investigate the inheritance of foreign genes, a two-way cross between wild-type and transgenic plants was used. Seeds from reciprocal crossing and selfing of transgenic and wild-type plants were grown on medium containing 500 mg.L⁻¹ spectinomycin. In this medium, only seeds containing the *aadA* selectable marker gene will be able to germinate normally and produce green seedlings, while non-transgenic seeds form albino seedlings that are unable to continue growing in this medium.

3.6. Evaluation of *IGF-1* Protein Expression by SDS-PAGE

Total soluble protein (TSP) was extracted from the leaf tissue of transgenic plants by the method described by Cahoon and coworkers (29) Approximately 50 µg

of TSP was loaded in each well from SDS-PAGE gel. Proteins were stained on the gel using Coomassie Blue solution (0.1% Coomassie blue, 50% methanol and 10% acetic acid). Finally, the gel was decolorized with a solution containing 20% methanol and 10% acetic acid.

4. Results

4.1. *IGF-1* Gene Transfer by Biolistic Gun Method and Selection of Potential Transgenic Plants

The bombarded leaves (**Fig. 2A**) were cut in pieces and placed on medium containing 500 mg.L⁻¹ spectinomycin. After about 4 weeks of selection, most of the leaf pieces bleached out and there were only a few green segments left, some of which regenerated into small seedlings after about 3 weeks (**Fig. 2B**). Of the 4 seedlings regenerated from 5 shoots using the hepta adapter, only one showed the desired band in PCR (**Fig. 2C**), and the rest were probably escapes or spontaneous mutations.

4.2. Creation of Homoplasmic Transplastomic Plants

Putative transgenic line was selected four generations on the regeneration medium containing 500 mg.L⁻¹ spectinomycin to reach the homoplasmic transplastomic stage. In addition to PCR, to demonstrate successful transmission and expression of the *aadA* selectable marker gene in transgenic plants and to rule out the possibility of spectinomycin resistance due to spontaneous mutation, a test for resistance to another

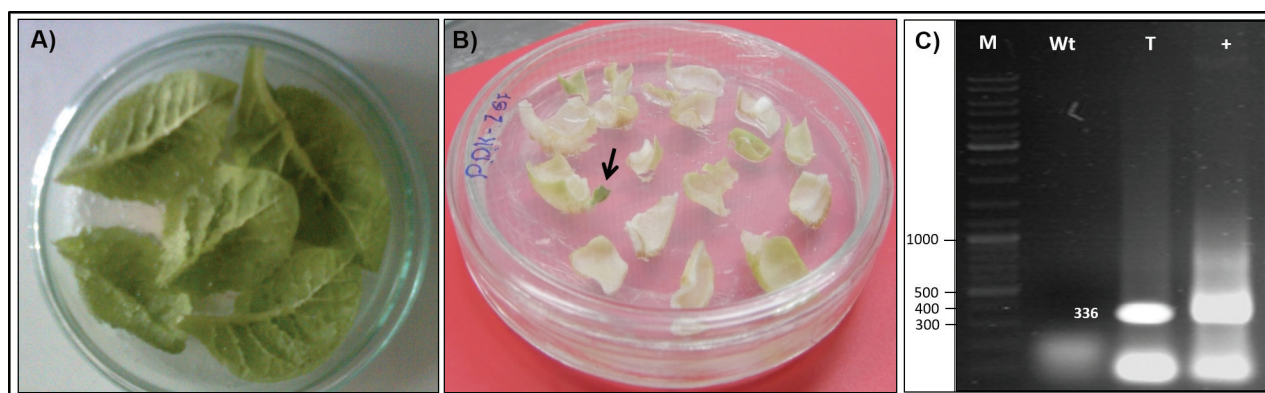

Figure 2. A) Petri dishes containing young tobacco leaves prepared for *IGF-1* gene transfer using a biolistic gun. B) Selection of leaf fragments bombarded with pRB94-IGF1 vector on medium containing 500 mg.L⁻¹ spectinomycin. An example of a regenerated seedling is shown with an arrow. C) Electrophoresis of the PCR product for *IGF-1* gene amplification in the transgenic plant. The formation of an expected specific band of 336 bp indicates the successful transfer of the *IGF-1* gene to selected plant line. M: Molecular weight marker; Wt: Wild type; T: Selected transgenic candidate; +: Positive control (pRB94-IGF1).

aminoglycoside antibiotic, including streptomycin, was performed at a concentration of 500 mg.L⁻¹, (data not shown). Regenerated plants from the fourth selection round of transgenic line were transferred to the greenhouse for growth and seed production. These plants were phenotypically similar to wild type (**Fig. 3A**), and produced normal seeds.

4.3. Confirmation of IGF-1 Gene Expression at the Transcriptional Level

RT-PCR test was used to confirm the expression of *IGF-1* gene at the transcriptional level in transgenic plants. The results of this experiment showed that unlike the wild type, the selected transgenic line contains transcripts of *IGF-1* gene and as a result, the expression of this gene in transgenic plants is successful at the transcriptional level (**Fig. 3B**)

4.4. Investigation of Transgene Inheritance and Confirmation of Homoplasmy Through Progeny Test

To prove the transfer of the foreign gene into the chloroplast genome, its inheritance in the transgenic line was evaluated through reciprocal crosses. The results of this experiment showed that when wild-type plants are fertilized by the pollens of transgenic plant, the selectable marker gene is not transferred to the resulting progenies, and these seeds, like wild type, are sensitive to the spectinomycin antibiotic (**Fig. 3C**). Conversely, when the transgenic line was used as the maternal parent, all seeds became resistant to the spectinomycin, like the seeds derived from selfing of the transgenic line (**Fig. 3C**). These results indicate that the inheritance of the *aadA* selectable marker gene is cytoplasmic and the transgene has been successfully transferred to the plastid genome. It should be noted that the uniformity of transgenic plant seeds for spectinomycin resistance, as a sensitive method (27), indicates the degree of homoplasmy in transgenic plants.

4.5. Confirmation of IGF-1 Gene Insertion in to Plastid Genome by Southern Blot Method

To confirm the physical presence of *IGF-1* gene in the chloroplast genome of transgenic plants and seeds resulting from their self-pollination, Southern blot analysis was used. According to the tobacco chloroplast genome map (NCBI accession number: NC_001879.2), after successful insertion of foreign genes at the designated site (**Fig. 1B**), by cutting the transgenic

plastome with the *Bgl*III restriction enzyme, which cuts the transplastome in areas outside the flanking regions, it is expected to obtain a 5528 bp fragment containing foreign genes. Unlike the wild-type plant, the 4th-regeneration-round transgenic plant and its progenies showed the desired band in this experiment (**Fig. 3D**), confirming the successful insertion of the foreign genes into the chloroplast genome of the transgenic plant, and its transfer to the next generation offspring.

4.6. Evaluation of Transgenic Plant Proteins by SDS-PAGE Method

SDS-PAGE gel analysis was performed to evaluate the expression status of transgenic plant proteins and the possibility of identifying IGF-1 protein. The total soluble protein status of the transgenic plant was almost similar to that of the wild-type plant (**Fig. 3E**). However, in the region of about 12 kDa, where the size of IGF-1 protein is also in this range (12.8 kD), the accumulation of proteins was much higher than in the wild type, which is probably mainly related to the expression and accumulation of IGF-1 protein.

5. Discussion

In this study, the transfer and expression of human *Insulin-Like Growth Factor 1 (IGF-1)* cDNA in tobacco chloroplasts was investigated. From 5 shots using the Hepta adapter, one true transformant was selected by PCR method, which is relatively acceptable for gene transfer to chloroplasts (17, 30). Due to the precise transfer of foreign genes to a predetermined region in the chloroplast genome using the homologous recombination, there is no position effects in chloroplast transformation (17). Therefore, a single plastid transgenic line will be sufficient for further experiments. Four rounds of selection on regeneration medium containing high concentrations of spectinomycin (500 mg.L⁻¹) eliminated all wild-type plastomes and replaced them with transplastomes, so that all seeds obtained from self-pollination of the transgenic plant were antibiotic resistant, which is a very important sign to achieve the homoplasmic stage (30, 31). If the homoplasmic stage is not established, the wild-type plastid genome will multiply rapidly in the absence of selective agent, leading to removal of transgenic plastid genome copies and loss of antibiotic resistance very rapidly (30).

Integration of *IGF-1* gene into the chloroplast genome

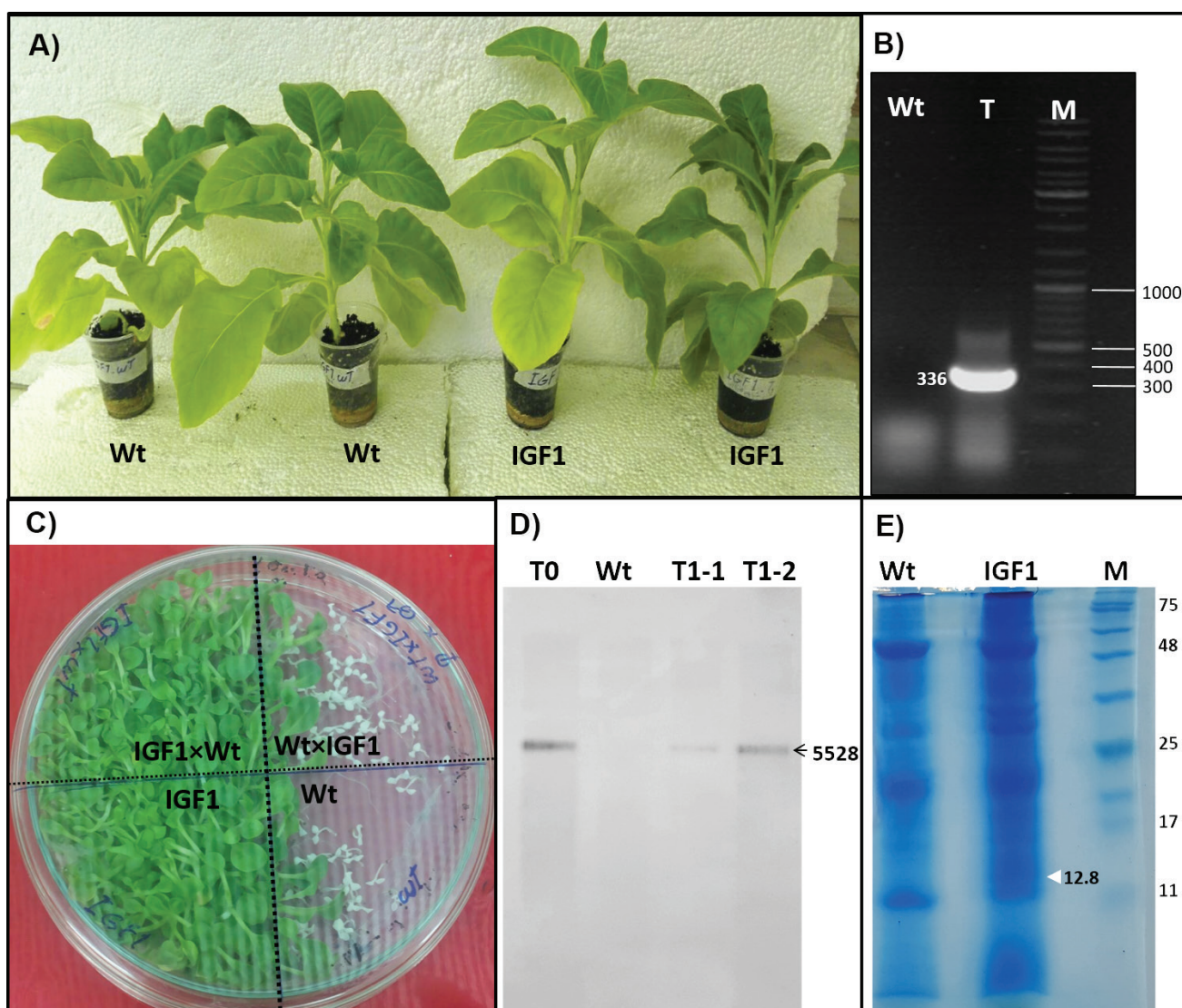

Figure 3. **A)** IGF-1 transplastomic plants after four weeks of growth in the greenhouse. The growth and development of transgenic plants was normal and there was no difference between them and wild type. These plants also produced normal seeds. **B)** Agarose gel electrophoresis of RT-PCR result in selected transgenic line. Unlike the wild type, the predicted 336-bp *IGF-1* band is formed in the transgenic line. **C)** The seed sensitivity test results of the progenies obtained from the reciprocal crosses between the transgenic line and the wild type. When Wt was used as maternal parent, progenies were sensitive to spectinomycin as Wt (right). Conversely, when the transgenic line was used as maternal parent, the seeds showed antibiotic resistance (left). **D)** The result of the Southern blot test to prove the physical presence of the *IGF-1* gene in the genome of the transgenic chloroplast line and its progenies. Using the *IGF-1* sequence as a probe, in contrast to the wild type, in the 4th-regeneration-round transgenic line (T0) and the two plants obtained from its selfing (T1-1 and T1-2), the 5528 bp band obtained by cutting the plastid genome with the *Bgl*III enzyme that cuts outside the flanking region (**Fig. 1B**). This test also rules out the possibility of foreign gene transfer to the nuclear genome. **E)** SDS-PAGE gel electrophoresis results of transgenic plant total soluble protein compared with wild type. In the range of 12 kDa, the accumulation of IGF-1 protein in the transgenic line is higher than the wild type, which is probably mainly related to the expression of IGF-1 protein with a size of about 12.8 kDa. The size of DNA and protein bands are indicated in base pairs and kD, respectively.

was confirmed by two methods, including progeny test and Southern blot analysis (**Fig. 3**). Given that the chloroplast organelle is derived from prokaryotic ancestors (32), it is unlikely that the selectable marker gene will be expressed if transferred to the nucleus genome, although in rare cases it occurs by modifying the promoter or using adjacent nuclear gene promoters (33). Cytoplasmic maternal inheritance of the selectable marker gene in reciprocal crosses between the transgenic plant and the wild type, demonstrated the transfer of the selectable marker gene into the chloroplast organelle (**Fig. 3C**). These results were also confirmed using the Southern blot method (**Fig. 3D**). RT-PCR analysis confirmed *IGF-1* gene expression at the transcription level. Tobacco plastid rRNA operon promoter (Prn) was used to control transcription of *IGF-1* gene. This promoter has strong transcriptional activity with recognition elements for both Nuclear- (NEP) and Plastid- encoded (PEP) RNA polymerases (34). For this reason, the promoter has also been used to transcribe selectable marker gene to increase the chances for early transgenic cells to survive in the early stages of gene transfer to organelle, which a small number of transgenic plastid genome copies exist. In a study by Daniell *et al.* (2009), the PsbA promoter, which can only be recognized by the PEP RNA polymerase that is usually active in the presence of light, was used (25). Also, in this study, to increase IGF-1 protein expression, we used a modified version of the Prn promoter, in which the 5'UTR of gene 10 from *E. coli* T7 phage and the downstream box (T7g10 DB) is fused to the promoter. This sequence has a significant effect on RNA stability and increased translation efficiency, and can lead to greater expression of foreign proteins (26). In the study of total soluble protein of transgenic plant by SDS-PAGE method, the protein accumulation was high in the range of 12 kDa, which is probably partly due to the high expression of IGF-1 protein with a size of 12.8 kDa. However, due to the accumulation of some natural wild-type proteins in this area (**Fig. 3E**), the detection of foreign proteins in this area is difficult and these results need to be confirmed by more accurate experiments such as Western blotting. In this study, a natural version of human *IGF-1* was used without modification of codon usage and its adaptation to tobacco chloroplasts. Daniell *et al.* (2009) also showed that the difference in *IGF-1* expression between the synthetic codon-usage-optimized version

and the natural version was negligible in chloroplast (25).

Cytoplasmic maternal inheritance of the chloroplast genome in genetically modified plants, as an efficient method for transgene containment and preventing its spread in nature, is valuable for the safe production of the transgenic crop in the field (35). In a few studies, the probability of foreign gene transmission through pollen grains has been reported to be around 2.86×10^{-6} , which is a very low and insignificant probability (18, 36). Because of such unique benefits, transgenic chloroplasts can have many applications as important biological reactors for the production of human pharmaceutical proteins (37). It should be noted that, appropriate biological activity of proteins produced by plant systems, including IGF-1, in human target cells has been reported in previous studies (12, 14, 24, 37).

Acknowledgments

The Biotechnology Development Council and Azarbaijan Shahid Madani University are acknowledged for the financial support of this research. The author thanks Dr. Maghsoud Pazhouhandeh, Mona Bordbar, Neda Hassanpour and Maryam Bagheri for their assistance.

References

1. Yakar S, Rosen CJ, Beamer WG, Ackert-Bicknell CL, Wu Y, Liu JL, *et al.* Circulating levels of IGF-1 directly regulate bone growth and density. *J Clin Invest.* 2002;**110**(6):771-781, doi: 10.1172/JCI15463.
2. Jeong W, Song G, Bazer FW, Kim J. Insulin-like growth factor I induces proliferation and migration of porcine trophectoderm cells through multiple cell signaling pathways, including protooncogenic protein kinase 1 and mitogen-activated protein kinase. *Mol Cell Endocrinol.* 2014;**384**(1-2):175-184, doi: 10.1016/j.mce.2014.01.023.
3. Peruzzi F, Prisco M, Dews M, Salomoni P, Grassilli E, Romano G, *et al.* Multiple signaling pathways of the insulin-like growth factor 1 receptor in protection from apoptosis. *Mol Cell Biol.* 1999;**19**(10):7203-7215, doi: 10.1128/mcb.19.10.7203.
4. Kim SO, Lee YI. High-level expression and simple purification of recombinant human insulin-like growth factor I. *J Biotechnol.* 1996;**48**(1-2):97-105, doi: 10.1016/0168-1656(96)01402-2.
5. Rosenbloom AL, Guevara Aguirre J, Rosenfeld RG, Fielder PJ. The little women of Loja--growth hormone-receptor deficiency in an inbred population of southern Ecuador. *N Engl J Med.* 1990;**323**(20):1367-1374, doi: 10.1056/NEJM199011153232002.
6. Backeljauw P. Therapy with recombinant human IGF-1 for children with primary insulin-like growth factor-I deficiency. *Growth Horm IGF Res.* 2020;**51**:22-26, doi: 10.1016/j.

- ghir.2020.01.001.
7. Petriczko E, Jackowski T, Horodnicka-Jozwa A, Wikiera B, Noczynska A, Korpala-Szczyrska M, *et al.* Treatment of severe primary IGF-1 deficiency using rhIGF-1 preparation - first three years of Polish experience. *Endokrynol Pol.* 2019;**70**(1):20-27, doi: 10.5603/EP.a2018.0074.
 8. Joly JC, Leung WS, Swartz JR. Overexpression of Escherichia coli oxidoreductases increases recombinant insulin-like growth factor-I accumulation. *Proc Natl Acad Sci U S A.* 1998;**95**(6):2773-2777, doi: 10.1073/pnas.95.6.2773.
 9. Gill R, Verma C, Wallach B, Urso B, Pitts J, Wollmer A, *et al.* Modelling of the disulphide-swapped isomer of human insulin-like growth factor-1: implications for receptor binding. *Protein Eng.* 1999;**12**(4):297-303, doi: 10.1093/protein/12.4.297.
 10. Streatfield SJ. Approaches to achieve high-level heterologous protein production in plants. *Plant Biotechnol J.* 2007;**5**(1):2-15, doi: 10.1111/j.1467-7652.2006.00216.x.
 11. Giddings G, Allison G, Brooks D, Carter A. Transgenic plants as factories for biopharmaceuticals. *Nat Biotechnol.* 2000;**18**(11):1151-1155, doi: 10.1038/81132.
 12. Yao J, Weng Y, Dickey A, Wang KY. Plants as factories for human pharmaceuticals: Applications and challenges. *Int J Mol Sci.* 2015;**16**(12):28549-28565, doi: 10.3390/ijms161226122.
 13. Panahi M, Alli Z, Cheng X, Belbaraka L, Belgoudi J, Sardana R, *et al.* Recombinant protein expression plasmids optimized for industrial E. coli fermentation and plant systems produce biologically active human insulin-like growth factor-1 in transgenic rice and tobacco plants. *Transgenic Res.* 2004;**13**(3):245-259, doi: 10.1023/b:trag.0000034619.21613.d0.
 14. Desai PN, Shrivastava N, Padh H. Production of heterologous proteins in plants: strategies for optimal expression. *Biotechnol Adv.* 2010;**28**(4):427-423, doi: 10.1016/j.biotechadv.2010.01.005.
 15. Meyers B, Zaltsman A, Lacroix B, Kozlovsky SV, Krichevsky A. Nuclear and plastid genetic engineering of plants: comparison of opportunities and challenges. *Biotechnol Adv.* 2010;**28**(6):747-756, doi: 10.1016/j.biotechadv.2010.05.022.
 16. De Cosa B, Moar W, Lee SB, Miller M, Daniell H. Overexpression of the Bt cry2Aa2 operon in chloroplasts leads to formation of insecticidal crystals. *Nat Biotechnol.* 2001;**19**(1):71-74, doi: 10.1038/83559.
 17. Maliga P. Plastid transformation in higher plants. *Annu Rev Plant Biol.* 2004;**55**:289-313, doi: 10.1146/annurev.arplant.55.031903.141633
 18. Ruf S, Karcher D, Bock R. Determining the transgene containment level provided by chloroplast transformation. *Proc Natl Acad Sci U S A.* 2007;**104**(17):6998-7002, doi: 10.1073/pnas.0700008104.
 19. Daniell H, Singh ND, Mason H, Streatfield SJ. Plant-made vaccine antigens and biopharmaceuticals. *Trends Plant Sci.* 2009;**14**(12):669-679, doi: 10.1016/j.tplants.2009.09.009.
 20. Staub JM, Garcia B, Graves J, Hajdukiewicz PT, Hunter P, Nehra N, *et al.* High-yield production of a human therapeutic protein in tobacco chloroplasts. *Nat Biotechnol.* 2000;**18**(3):333-338, doi: 10.1038/73796
 21. Leelavathi S, Reddy VS. Chloroplast expression of His-tagged GUS-fusions: a general strategy to overproduce and purify foreign proteins using transplastomic plants as bioreactors. *Molecular Breeding.* 2003;**11**:49-58, doi: 10.1023/A:1022114427971.
 22. Arlen PA, Falconer R, Cherukumilli S, Cole A, Cole AM, Oishi KK, *et al.* Field production and functional evaluation of chloroplast-derived interferon-alpha2b. *Plant Biotechnol J.* 2007;**5**(4):511-525, doi: 10.1111/j.1467-7652.2007.00258.x.
 23. Ruhlman T, Ahangari R, Devine A, Samsam M, Daniell H. Expression of cholera toxin B-proinsulin fusion protein in lettuce and tobacco chloroplasts--oral administration protects against development of insulinitis in non-obese diabetic mice. *Plant Biotechnol J.* 2007;**5**(4):495-510, doi: 10.1111/j.1467-7652.2007.00259.x.
 24. Daniell H, Ruiz G, Denes B, Sandberg L, Langridge W. Optimization of codon composition and regulatory elements for expression of human insulin like growth factor-1 in transgenic chloroplasts and evaluation of structural identity and function. *BMC Biotechnol.* 2009;**9**:33. doi: 10.1186/1472-6750-9-33.
 25. Darabi S, Ramezani S, Ahmadabadi M. Cloning of human insulin-like growth factor gene in plant expression vectors. *J Agri Biotechnol.* 2017;**9**(1):15-30 (In Persian).
 26. Kuroda H, Maliga P. Complementarity of the 16S rRNA penultimate stem with sequences downstream of the AUG destabilizes the plastid mRNAs. *Nucleic Acids Res.* 2001;**29**(4):970-975, doi: 10.1093/nar/29.4.970.
 27. Svab Z, Hajdukiewicz P, Maliga P. Stable transformation of plastids in higher plants. *Proc Natl Acad Sci U S A.* 1990;**87**(21):8526-8530, doi: 10.1073/pnas.87.21.8526.
 28. Doyle JJ, Doyle JL. Isolation of plant DNA from fresh tissue. *Focus.* 1990;**12**:13-15.
 29. Cahoon EB, Shanklin J, Ohlrogge JB. Expression of a coriander desaturase results in petroselinic acid production in transgenic tobacco. *Proc Natl Acad Sci U S A.* 1992;**89**(23):11184-11188, doi: 10.1073/pnas.89.23.11184.
 30. Bock R. Transgenic plastids in basic research and plant biotechnology. *J Mol Biol.* 2001;**312**(3):425-438, doi: 10.1006/jmbi.2001.4960.
 31. Ahmadabadi M. Gene transfer into plastids: A review on complete mechanism, recent advances and existing obstacles. *Modern Genet J.* 2010;**5**(2):5-19 (In Persian).
 32. Gray MW. Rethinking plastid evolution. *EMBO Rep.* 2010;**11**(8):562-563, doi: 10.1038/embor.2010.107.
 33. Stegemann S, Hartmann S, Ruf S, Bock R. High-frequency gene transfer from the chloroplast genome to the nucleus. *Proc Natl Acad Sci U S A.* 2003;**100**(15):8828-8833, doi: 10.1038/embor.2010.107.
 34. Bock R, Khan MS. Taming plastids for a green future. *Trends Biotechnol.* 2004;**22**(6):311-318, doi: 10.1016/j.tibtech.2004.03.005.
 35. Daniell H. Transgene containment by maternal inheritance: effective or elusive? *Proc Natl Acad Sci U S A.* 2007;**104**(17):6879-6880, doi: 10.1073/pnas.0702219104.
 36. Svab Z, Maliga P. Exceptional transmission of plastids and mitochondria from the transplastomic pollen parent and its impact on transgene containment. *Proc Natl Acad Sci U S A.* 2007;**104**(17):7003-7008, doi: 10.1073/pnas.0700063104.
 37. Adem M, Beyene D, Feyissa T. Recent achievements obtained by chloroplast transformation. *Plant Methods.* 2017;**13**:30, doi: 10.1186/s13007-017-0179-1.