

Expression, regulation and mechanism of action of the miR-17-92 cluster in tumor cells (Review)

LI-LI FANG^{1*}, XING-HUI WANG^{2*}, BAO-FEI SUN¹, XIAO-DONG ZHANG³,
XU-HUI ZHU³, ZI-JIANG YU¹ and HENG LUO^{2,3}

¹Guizhou Medical University; ²Key Laboratory of Chemistry for Natural Products of Guizhou Province and Chinese Academy of Sciences, Guiyang, Guizhou 550004; ³Beijing Chao-Yang Hospital, Capital Medical University, Beijing 100020, P.R. China

Received January 12, 2017; Accepted September 11, 2017

DOI: 10.3892/ijmm.2017.3164

Abstract. MicroRNAs (miRNAs), a class of short, single-stranded non-coding RNAs, regulate and control gene expression in eukaryotes by degrading mRNA at the post-transcriptional level. Regulation by miRNAs involves a plethora of biological processes, such as cell differentiation, proliferation, metastasis, metabolism, apoptosis, tumorigenesis and others. miRNAs also represent a powerful tool in disease diagnosis and prognosis. The miR-17-92 cluster, one of the most extensively investigated microRNA clusters, comprises six mature miRNA members, including miR-17, miR-18a, miR-19a, miR-19b, miR-20a and miR-92a. Originally identified as being involved in tumorigenesis, it is currently evident that the expression of the miR-17-92 cluster is upregulated in a wide range of tumor cells and cancer types; thus, this cluster has been identified as a potential oncogene. Considering the growing interest in the field of miR-17-92 research, we herein review recent advances in the expression and regulation of this cluster in various cancer cells, discuss the proposed mechanism of action for tumorigenesis and tumor development, and propose clinical and therapeutic applications for miR-17-92 cluster members, such as potential cancer biomarkers.

Contents

1. Introduction
2. Characteristics of the miRNA-17-92 cluster
3. Expression and regulation of the miRNA-17-92 cluster in tumor cells
4. Mechanism of action of the miR-17-92 cluster in tumorigenesis and tumor development
5. Clinical applications and perspectives for the miRNA-17-92 cluster

1. Introduction

MicroRNAs (miRNAs) are a class of single-stranded, non-coding small RNAs, ~22 nucleotides (nt) in length, that are able to bind to target mRNAs via partial or complete complementary base pairing. miRNAs regulate gene expression and may inhibit oncogenes or tumor-suppressor genes at the post-transcriptional level (1). miRNAs take the RNA induced silencing complex (RISC) to the target mRNA containing complementary sequences, and induce its degradation (2). miRNAs are derived from the transcription of a set of protein-coding genes, but are structurally and functionally different from the mRNA transcribed by the common gene. In particular, each miRNA originates from a longer primary transcript, referred to as pri-miRNA, which is transcribed in the nucleus from genomic DNA by the RNA polymerase II. The pri-miRNA is then cleaved by the specific endonuclease Drosha into a pre-miRNA hairpin consisting of ~70 nt and containing the sequence complementary to the target mRNA (3). This pre-miRNA hairpin is transported into the cytoplasm by the nuclear export protein exportin 5 and cleaved by Dicer to form a short double-stranded molecule, in which each strand is a mature miRNA (Fig. 1).

To date, ~8,000 genes coding for miRNAs have been identified in various organisms, such as plants, viruses and animals, including 1,000 human miRNAs that have been confirmed (4). It has been demonstrated that one single miRNA may regulate the expression of >200 target genes, and the expression of certain target mRNAs may also be regulated by several miRNAs. Overall, over one-third of structural human genes

Correspondence to: Dr Heng Luo, Key Laboratory of Chemistry for Natural Products of Guizhou Province and Chinese Academy of Sciences, 202 South Sha-chong Road, Guiyang, Guizhou 550004, P.R. China

E-mail: luoheng71050@aliyun.com

Dr Zi-Jiang Yu, Guizhou Medical University, 9 Beijing Road, Guiyang, Guizhou 550004, P.R. China

E-mail: yzj0112@126.com

*Contributed equally

Key words: miR-17-92 cluster, cancer cell, oncogene and tumor suppressor gene, mechanism, post-transcriptional regulation

were found to be regulated by miRNAs (5). miRNAs are involved in the regulation of a plethora of biological processes, such as cell differentiation, proliferation, metastasis, metabolism, apoptosis, tumorigenesis, angiogenesis and others. Considering their roles, it is not surprising that abnormal expression of miRNAs is associated with several pathologies, thus making miRNAs useful clinical biomarkers that may be used in the diagnosis, treatment and prognosis of tumors (6). As a consequence, numerous studies have demonstrated that miRNAs are directly implicated in the occurrence and development of cancer, thus attracting even more interest in the research field.

Approximately 60% of miRNAs may express independently, 15% as a cluster, and 35% cannot express, being located in introns. Clustered miRNAs have demonstrated a cooperative function in regulating gene expression (7). In 2005, He *et al* first discovered the miR-17-92 cluster, an oncogenic gene in human B-cell lymphomas (8). The aim of the present review was to summarize the functions and mechanisms through which the miR-17-92 cluster is involved in cancer, thus providing a theoretical basis to study the effect and molecular mechanism of the miR-17-92 cluster in regulating the development of prostate cancer cells.

2. Characteristics of the miRNA-17-92 cluster

miRNA clusters are mainly expressed in vertebrates and mammals, and result from genome duplication (9). As a consequence, miRNAs were classified as clusters due to their high sequence homology. The miR-17-92 cluster is a typical highly conserved polycistronic miRNA cluster, which is located in the human chromosome 13 open reading frame 25 (C13orf25), encoding six mature miRNAs, including miR-17, miR-18a, miR-19a, miR-19b, miR-20a and miR-92a (10). Both human miR-17 and miR-20a were included in the miR-17 family due to their high sequence homology (Fig. 2).

In detail, the miR-17-92 cluster has two paralogue gene clusters named miR-106a-363 and miR-106b-25. The miR-106A-363 cluster encodes for miR-106a, miR-18b, miR-20b, miR-19b-2, miR92a-2 and miR-363; the miR-106b-25 cluster encodes for miR-106b, miR-93 and miR-25 (Fig. 2). According to the homology of the seed-sequence, all these miRNAs have been grouped into four families, namely the miR-17, miR-92, miR-18 and miR-19 families (11). The miRNA sequences of the three clusters miR-17-92, miR-106b-25 and miR-106b-363 were found to be highly similar, with overlapping functions (Fig. 2). Previous studies have demonstrated that murine knockout models for the miR-17-92 cluster died soon after birth due to lung function insufficiency and ventricular septal defects. The simultaneous deletion of both miR-17-92 and miR-106b-25 caused severe apoptosis of fetal liver cells and central nervous system cells in mice. However, the simultaneous or separated deletion of miR-106b-25 and miR-106a-363 did not affect the individual development (12). These results indicated that there are some overlapping roles in members of the miR-17 and miR-92 families within the miR-17-92 and miR-106b-25 clusters, while the miR-18 and miR-19 families, only present in the miR-17-92 cluster, play a critical role in developmental processes. A recent study analyzed the expression of the miR-17-92 and miR-106b-25 clusters in spermatogonial stem

cells, demonstrating that the miR-106b-25 cluster may be upregulated in germ cells without affecting spermatogonial development when the miR-17-92 cluster is deleted (13). This indicated that the miR-17-92 and miR-106b-25 clusters may synergistically regulate reproductive development.

3. Expression and regulation of the miRNA-17-92 cluster in tumor cells

Expression and functions of miR-17/20a. The miRNA-17-92 cluster may be highly expressed in a wide range of tumor cells and types of cancer, such as lung, breast, pancreatic, prostate and thyroid cancer, as well as lymphomas (7,14). Therefore, it is also referred to as 'oncomiR1'. The majority of the previous studies have been aimed at studying the potential carcinogenicity of the miR-17-92 cluster, but this cluster also possesses antitumor properties. For example, the miR-17 component acts as a tumor suppressor in breast and prostate cancer by individually targeting AIB1 and PCAF (15,16). Of note, the development of erythroleukemia induced by miR-92a was inhibited by the co-expression of miR-92a and miR-17, indicating that the expression of miR-17 may inhibit the carcinogenesis induced by miR-92a (17). Moreover, it has been demonstrated that miR-17-5p is able to induce prostate tumor growth and invasion by regulating TIMP3 (18). In addition, miR-20a may have different functions in various pathological processes, with a dual behavior (acts as an oncogene or tumor suppressor). In fact, several studies have demonstrated that miR-20a was found to be upregulated in the serum of hepatitis C virus-infected individuals, and in uveal melanoma, osteosarcoma, neuroglioma, undifferentiated thyroid cancer, cervical, gastric and prostate cancer, while it was down-regulated in breast, liver and pancreatic cancer cells (19-26).

Expression and functions of miR-19/miR-92a/miR-18a. Several studies reported miR-19, one of the major oncogenes in the miR-17-92 cluster, to be highly expressed in gastric and prostate cancer (27). In addition, miR-18a was found to be highly expressed in breast, nasopharyngeal, prostate and colorectal cancer (28). In glioma, colorectal adenoma, renal clear cell carcinoma, small-cell lung cancer, hepatocellular carcinoma, multiple myeloma and non-Hodgkin lymphoma, the transcriptional level of miR-92a was found to be higher compared with that of other miRNAs present in the miR-17-92 cluster (29-31). However, the expression of the same miRNA in breast cancer tissues was lower compared with normal tissues. Further studies have also suggested that the expression level of miR-92a may be associated with the size of the tumor and lymph node metastasis.

Recent evidence demonstrated that the expression of miR-17, miR18a and miR-19a increased during tumor angiogenesis, displaying proangiogenic functions through the regulation of the target protein kinase JAK1, while miR-92a decreased and inhibited vascular network formation by regulating integrin $\alpha 5$ (ITG $\alpha 5$) (32). In fact, the overexpression of miR-17, miR-18a and miR-20a partially restored the impaired endothelial network formation, but suppressed angiogenic sprout formation in zebrafish (33). There have been no related studies on human cells and tissues to date; however, this evidence suggests that miR-92a is a negative regulator of angiogenesis.

The function of miRNAs as tumor suppressors is similar to that of tumor suppressor genes: Their downregulation or

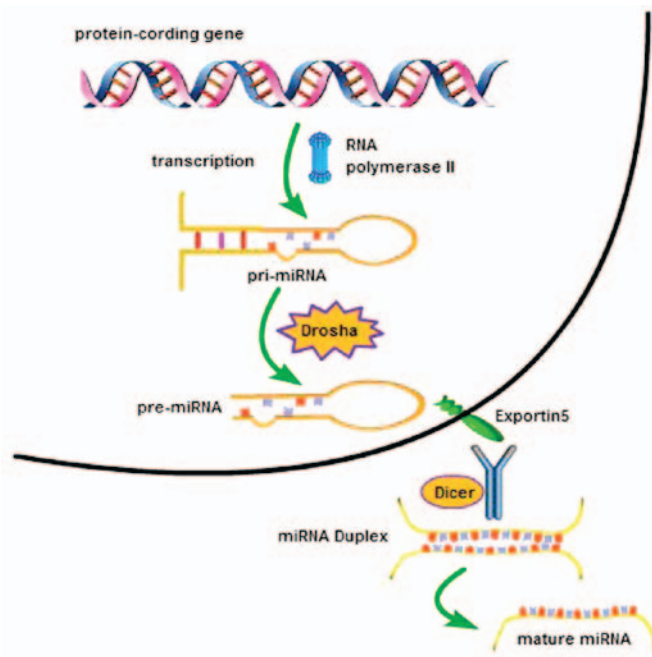

Figure 1. Pri-miRNA is transcribed in the nucleus by the RNA polymerase II from a protein-coding gene and subsequently processed by the type III RNase Drosha into pre-miRNA. The pre-miRNA is then transported to the cytoplasm by exportin 5 and cleaved by Dicer into a double-stranded molecule in which each strand is a mature miRNA.

inactivation directly leads to the occurrence and development of cancer. However, only few studies provided evidence enabling a better understanding of the main function of the miR-17-92 cluster, considering that it may promote carcinogenesis as well as act as a tumor suppressor. Our study group aimed to investigate the effectiveness of the miR-17-92 cluster as a diagnostic biomarker in different stages of prostate cancer development, as well as the molecular mechanism through which this cluster regulates prostate cancer cell growth, migration and invasion, with the aim to determine its potential use in clinical practice.

4. Mechanism of action of the miR-17-92 cluster in tumorigenesis and tumor development

Mechanism of action of the miR-17-92 cluster in tumorigenesis. Tumorigenesis is associated with a disorder of the mechanism that maintains normal cell activity. It is associated with multiple complex processes, such as excessive cell proliferation, and interruptive apoptosis and differentiation, among others. miRNAs play an important role in tumorigenesis and tumor development, participating in various stages of these processes. For example, a disorder in the regulation of the interactions among miRNAs and target genes may lead to the occurrence of a tumor. In cancer, the different regulation of targeting genes allows miRNAs to have various biological functions, as oncogenes or tumor suppressors.

The miR-17-92 cluster plays a crucial role in tumorigenesis, mainly via the activation of oncogenes and the inactivation of tumor suppressor genes. The expression of cell cycle regulatory genes plays an important role in tumorigenesis. For example, it has been demonstrated that the miR-17-92 cluster can inhibit the expression of the tumor suppressor p21

and the apoptotic gene *Bim* in lymphoma (34). Furthermore, miR-20a acts as an oncogene and, through inhibition of the expression of early growth response (EGR)2, it may promote cell proliferation and induce cell cycle progression in osteosarcoma (21). Accordingly, miR-20a regulates carcinogenesis in gastric cancer cells through the EGR2 signaling pathway (25). By contrast, miR-17-5p exerts an antitumor effect by inhibiting the expression of AIB1 in breast cancer (15,35).

The miRNA-17-92 cluster promotes tumor cell proliferation and apoptosis by regulating different target genes and signaling pathways. Several transcription factors regulate the miR-17-92 cluster, affecting its carcinogenic activity. The first confirmed miR-17-92 transcription factor was MYC, which is involved in multiple mechanisms regulating gene expression. Overexpressed in approximately half of human cancers, MYC binds to specific genomic sites directly activating miR-17-92 expression. MYC may also inhibit specific target genes, such as Sin3b, Btg1 and the apoptosis-regulating factor *Bim* (14,36). In neuroblastoma cells, the miR-17-92 cluster is upregulated via MYCN (37). Along with MYC, p21 represents an important target of the miRNA-17-92 cluster. The expression of p21 may be inhibited by c-Myc, which promotes tumor cell proliferation and, thus, tumor growth. It has been demonstrated that miR-20 affects the regulatory factor CDKN1A/p21, which is activated by transforming growth factor (TGF)- β , thus preventing the antiproliferative effect induced by TGF- β in colorectal cancer (38). In addition, the transcription factors E2F1, E2F2 and E2F3, which are members of the E2F family, have been identified as target genes of miR-17 and miR-20a (39-41). In fact, the suppression of miR-17-92 in cervical carcinoma led to the upregulation of E2F1 (24). Overall, it may be argued that the regulation of gene expression by miRNAs may be implemented through mechanisms similar to those of transcription factors.

The regulation of almost all cellular processes occurs through several signaling pathways. The Janus kinase/signal transducer and activator of transcription (JAK-STAT) pathway plays a pivotal role in the mechanism of action of the miR-17-92 cluster. In multiple myeloma, miR-17-92 enhances cell proliferation and inhibits cell apoptosis by inhibiting the tumor suppressor gene SOCS-1 and activating the JAK-STAT pathway (42). Recent studies have revealed that phosphoinositide-3 kinase (PI3K)/AKT/mammalian target of rapamycin is another important axis that regulates tumor development by inhibiting apoptotic and activating anti-apoptotic factors, thus promoting cell survival. Once activated, AKT regulates cell proliferation, growth and survival by phosphorylating different downstream targets, such as enzymes, kinases, transcription factors and others. The activation of this pathway may downregulate the expression of the tumor suppressor gene p53, thus inhibiting apoptosis. Another tumor suppressor gene is phosphatase and tensin homolog (PTEN), a phosphatase of phosphatidylinositol (3,4,5)-trisphosphate, which is the first to be found in the tumor suppressor gene and, through downregulation of the PI3K/AKT signaling pathway, promotes apoptosis, thus acting as a tumor suppressor (Fig. 3). The miR-17-92 cluster activates the AKT/glycogen synthase kinase pathway through downregulation of the expression of PTEN, and promotes cell proliferation and angiogenesis through the PI3K/AKT pathway (43,44). The expression of the pro-apoptotic factor *Bim* may be inhibited by the miR-17-92 cluster, thus blocking apoptosis (34). *Bim* is

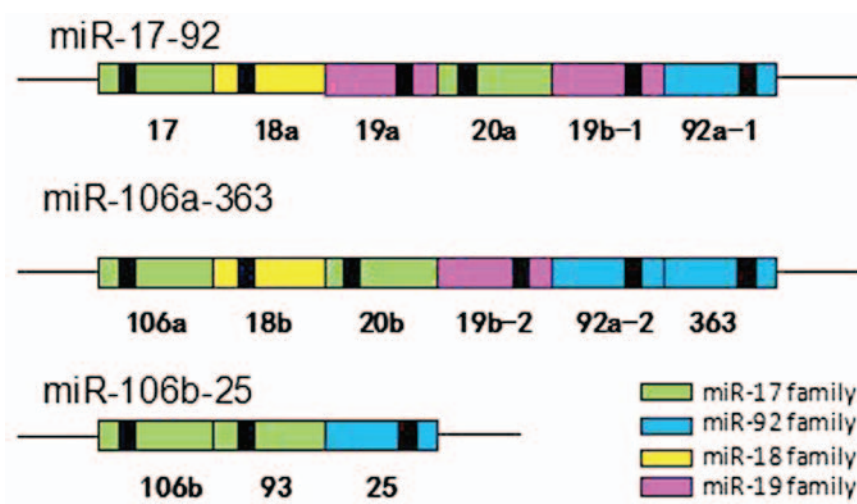

Figure 2. Schematic representation of the structure of the miR-17-92, miR-106b-25 and miR-106b-363 clusters. miR-17, miR-20a, miR-106a, miR-20b, miR-106b and miR-93 are labeled as green and grouped in the miR-17 family. miR-92, miR-18 and miR-19 families are labeled as blue, yellow and pink, respectively.

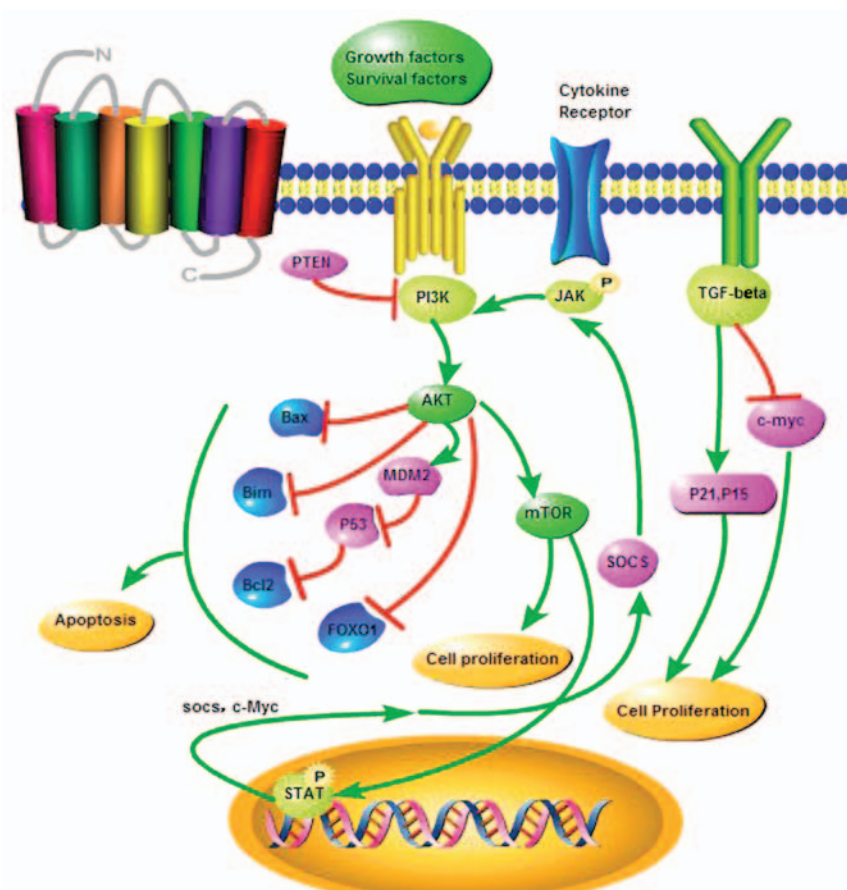

Figure 3. Principal target genes and signaling pathways involved in the miR-17-92 cluster regulation network. Janus kinase/signal transducer and activator of transcription (JAK-STAT), transforming growth factor (TGF)- β and phosphoinositide-3 kinase (PI3K)/AKT signaling pathways regulate tumor cell proliferation and apoptosis. Green arrows, activating effect; red lines, inhibitory effect. PTEN, phosphatase and tensin homolog; mTOR, mammalian target of rapamycin.

also a target of miR-92a, and it is associated with the tumor malignancy in colon adenoma (30).

Mechanism of action of the miR-17-92 cluster in tumor development

Effect of the miR-17-92 cluster on cancer stem cells. Cancer stem cells (CSCs), also referred to as tumor-initiating cells,

represent the origin of the primary tumor, with their capacity of self-renewal and multiple differentiation potential. CSCs play a crucial role in the occurrence, development, metastasis and recurrence of tumors. However, there is currently controversy regarding CSCs, although a growing volume of experimental evidence (e.g., flow cytometry, sorting technologies and animal models) support the CSC theory (45). CSCs maintain

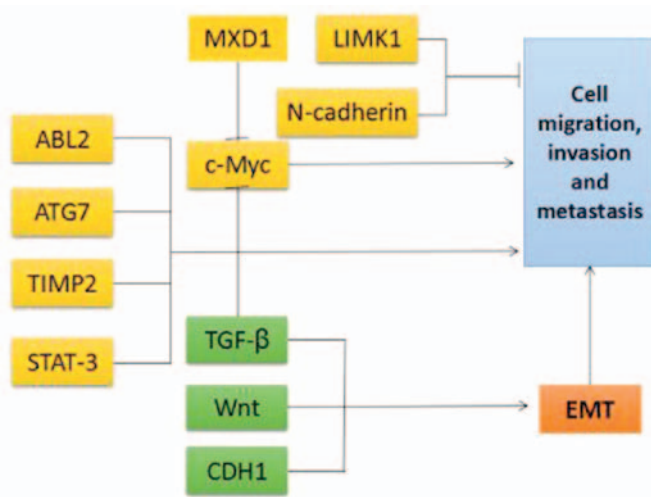

Figure 4. Target genes and signaling pathways regulated by the miR-17-92 cluster that are involved in tumor cell migration, invasion and metastasis. Green arrows, activating effect; red lines, inhibitory effect. TGF, transforming growth factor; STAT, signal transducer and activator of transcription; CDH, cadherin; TIMP, tissue inhibitor of metalloproteinases; MXD1, MAX dimerization protein 1; LIMK1, LIM domain kinase 1; EMT, epithelial-to-mesenchymal transition.

tumor cell viability by self-renewal and their unlimited proliferation ability. Specific miRNAs and long-chain non-coding RNAs regulate certain characteristics of tumor stem cells, including asymmetric cell division, high tumorigenicity, drug resistance, invasion and metastasis (46). Zagorac *et al* reported that the genetic targeting of DNMT1 through epigenetic reactivation of the miR-17-92 cluster in reprogrammed pancreatic cancer stem cells reduced their self-renewal (47). In addition, the overexpression of miR-17-92 reduced CSC self-renewal capacity *in vivo* by targeting multiple signaling cascade members, such as NODAL/ACTIVIN/TGF- β 1, and directly inhibiting the downstream targets p21, p57 and TBX3. miR-17-92, thus, represents a potential target for the prognosis of pancreatic cancer and may provide a guide to diagnosis and treatment (48).

Therefore, the reduction or elimination of the self-renewal ability of CSCs by miRNAs, such as the miR-17-92 cluster, may represent a promising new direction towards designing novel cancer therapies.

Epithelial-to-mesenchymal transition (EMT) and its role in tumor development. Epithelial and mesenchymal cells are the two main types of cells in human tissues. Epithelial cells exhibit polarity, and are connected to each other through adhesions, bridging and gap junctions. Conversely, mesenchymal cells do not exhibit polarity, lack intercellular junctions, and are able to migrate through the extracellular matrix. EMT is a biological process during which epithelial cells transform to cancer cells with mesenchymal characteristics, such as the ability to invade and migrate under physiological and pathological conditions. The expression of E-cadherin and markers of mesenchymal cells (N-cadherin, vimentin and fibronectin) represent the main characteristics of EMT, along with decreased cell adhesion (49). EMT is critical for normal embryonic development, wound healing, tissue regeneration, organ fibrosis, and it also occurs during tumor development,

invasion and metastasis (50). A study on colon and pancreatic cancer reported the presence of a mutual feedback loop between members of the miR-200 family and ZEB1, which is involved in the invasion and metastasis induced by EMT (51). The expression of miR-200 family members was significantly associated with the expression of E-cadherin, thus inhibiting the expression of ZEB1 and SIP1. By contrast, ZEB1 binds directly with the promoter region of miR-200, thus inhibiting the expression of genes and forming a double negative feedback pathway. Increased expression of miR-19 is able to trigger EMT in lung cancer cells, reduce cell adhesion, and enhance cell migration and invasion through regulating epithelial and mesenchymal proteins (52). In colon cancer, miR-17 induces EMT consistently with the cancer stem cell phenotype by regulating CYP7B1 expression (53). The expression of the miR-17-92 cluster is correlated with inhibition of EMT by reducing the expression of mesenchymal markers, such as N-cadherin, vimentin, Twist1, Slug and TCF8/ZEB1, and by promoting the expression of the epithelial marker E-cadherin (54).

The miRNA-17-92 cluster facilitates tumor cell migration, invasion and metastasis. The miR-17-92 cluster, acting as an oncogene, induces tumor cell invasion and metastasis by regulating its target genes. miR-19 may contribute to the development of c-Myc-induced lymphoma, particularly by playing a key role in stimulating lymphoma cell migration, invasion and metastasis (27). Similarly, miR-19a/b has been found to be upregulated in metastatic gastric cancer, in which it promotes cell migration, invasion and metastasis, by regulating the tumor suppressor MXD1, a c-Myc antagonist (55). It has been demonstrated that miR-92a directly targets the E-cadherin (CDH1) gene, which is associated with human esophageal squamous cell carcinoma (56). In aggressive leukemia, such as erythroleukemia caused by the activation of the Fli-1 gene by the Friend virus, miR-92a may accelerate the development of the Friend virus by regulating the p53 pathway (57). However, Ohyagi-Hara *et al* confirmed that miR-92a can directly target ITG α 5 and decrease the expression of ITG α 5 in ovarian cancer, thus inhibiting tumor cell adhesion, metastasis and proliferation (58). miR-20a can promote cell invasion and migration by targeting the ABL2 gene in prostate cancer, and TIMP2 and ATG7 in glioma stem cells and ovarian cancer (22,26,59). miR-20a was found to be highly expressed in undifferentiated thyroid carcinoma, and plays an antitumor role in thyroid cancer. Its effect is mainly exerted through the inhibition of the proliferation and invasion of thyroid cancer cells by targeting the LIMK1 gene (23). Reversely, STAT-3 downregulation inhibited malignant pleural mesothelioma cell invasion and tumor migration by miR-17 (Fig. 4) (60). All the abovementioned studies demonstrated that the miR-17-92 cluster may play different roles in several cancer tissues, but its mechanism of action remains to be elucidated by further studies. However, these findings provide novel insights to the treatment of different cancers.

5. Clinical applications and perspectives for the miRNA-17-92 cluster

miRNAs are key players in biological processes such as cell proliferation, differentiation, tumorigenesis, immune regulation

and several others. A number of studies have demonstrated specific expression of members of the miRNA-17-92 cluster in various diseases, particularly in different types of cancer, suggesting that the miRNA-17-92 cluster may represent a new direction for the diagnosis and treatment of cancer. Monitoring the expression changes of the members of the miRNA-17-92 cluster under specific tumor conditions may be a powerful tool for the early detection of cancer. The miRNA-17-92 cluster is also predicted to provide important supplementary tools for tumor classification, determination of the treatment plan and analysis of prognosis by clinicians. For example, the use of miR-17 antagonists represents a novel therapeutic approach to the treatment of chronic lymphocytic leukemia (61). In animal models, the intravenous injection of anti-miR-17-92 may cure allograft medulloblastoma by decreasing cell proliferation and suppressing tumor growth (62). Experiments on evaluating the effects of the overexpression and silencing of the miRNA-17-92 cluster in the embryonic and postnatal mouse heart demonstrated that this cluster may induce the proliferation of cardiac muscle cells. This technology may become a therapeutic target method for myocardial repair and regeneration (63). Recently, a close association was demonstrated between miR-92a and lymphoma metastasis in colorectal cancer, indicating that miR-92a may be a potential marker for colorectal cancer (64). Overall, the use of the miRNA-17-92 cluster in clinical practice represents a promising tool, considering the accumulating evidence on its specific functions. The study of miRNAs with clinical aims may pave the way to major advances in cancer treatment in the near future.

Acknowledgements

The authors are grateful to the staff members of the Analytical Center for Spectral Measurement and Activity Test Center for Antibacterial Activity of the Laboratory of Chemistry for Natural Products of Guizhou Province and the Chinese Academy of Sciences. The study was supported by the specific project of China Postdoctoral Science Foundation (grant no. 2015T80106), the Main Science Project of Guizhou Province [grant no. (2013)6012], the Postdoctoral Science Foundation of Beijing (grant no. 2015-ZZ-45) and the Natural Science Foundation of Guizhou Province [grant no. (2014)2099].

References

- Lai EC, Tomancak P, Williams RW and Rubin GM: Computational identification of *Drosophila* microRNA genes. *Genome Biol* 4: R42, 2003.
- Danielson LS, Reavie L, Coussens M, Davalos V, Castillo-Martin M, Guijarro MV, Coffre M, Cordon-Cardo C, Aifantis I, Ibrahim S, *et al*: Limited miR-17-92 overexpression drives hematologic malignancies. *Leuk Res* 39: 335-341, 2015.
- Visone R and Croce CM: miRNAs and cancer. *Am J Pathol* 174: 1131-1138, 2009.
- Mendes ND, Freitas AT and Sagot MF: Current tools for the identification of miRNA genes and their targets. *Nucleic Acids Res* 37: 2419-2433, 2009.
- Lewis BP, Burge CB and Bartel DP: Conserved seed pairing, often flanked by adenosines, indicates that thousands of human genes are microRNA targets. *Cell* 120: 15-20, 2005.
- Lu J, Getz G, Miska EA, Alvarez-Saavedra E, Lamb J, Peck D, Sweet-Cordero A, Ebert BL, Mak RH, Ferrando AA, *et al*: MicroRNA expression profiles classify human cancers. *Nature* 435: 834-838, 2005.
- Chhabra R, Dubey R and Saini N: Cooperative and individualistic functions of the microRNAs in the miR-23a-27a-24-2 cluster and its implication in human diseases. *Mol Cancer* 9: 232, 2010.
- He L, Thomson JM, Hemann MT, Hernando-Monge E, Mu D, Goodson S, Powers S, Cordon-Cardo C, Lowe SW, Hannon GJ, *et al*: A microRNA polycistron as a potential human oncogene. *Nature* 435: 828-833, 2005.
- Sun J, Gao B, Zhou M, Wang ZZ, Zhang F, Deng JE and Li X: Comparative genomic analysis reveals evolutionary characteristics and patterns of microRNA clusters in vertebrates. *Gene* 512: 383-391, 2013.
- Ota A, Tagawa H, Karnan S, Tsuzuki S, Karpas A, Kira S, Yoshida Y and Seto M: Identification and characterization of a novel gene, C13orf25, as a target for 13q31-q32 amplification in malignant lymphoma. *Cancer Res* 64: 3087-3095, 2004.
- Mendell JT: miRiad roles for the miR-17-92 cluster in development and disease. *Cell* 133: 217-222, 2008.
- Ventura A, Young AG, Winslow MM, Lintault L, Meissner A, Erkeland SJ, Newman J, Bronson RT, Crowley D, Stone JR, *et al*: Targeted deletion reveals essential and overlapping functions of the miR-17 through 92 family of miRNA clusters. *Cell* 132: 875-886, 2008.
- Tong MH, Mitchell DA, McGowan SD, Evanoff R and Griswold MD: Two miRNA clusters, Mir-17-92 (Mircl) and Mir-106b-25 (Mir3), are involved in the regulation of spermatogonial differentiation in mice. *Biol Reprod* 86: 72, 2012.
- Mogilyansky E and Rigoutsos I: The miR-17/92 cluster: A comprehensive update on its genomics, genetics, functions and increasingly important and numerous roles in health and disease. *Cell Death Differ* 20: 1603-1614, 2013.
- Hossain A, Kuo MT and Saunders GF: Mir-17-5p regulates breast cancer cell proliferation by inhibiting translation of AIB1 mRNA. *Mol Cell Biol* 26: 8191-8201, 2006.
- Gong AY, Eischeid AN, Xiao J, Zhao J, Chen D, Wang ZY, Young CY and Chen XM: miR-17-5p targets the p300/CBP-associated factor and modulates androgen receptor transcriptional activity in cultured prostate cancer cells. *BMC Cancer* 12: 492, 2012.
- Yang X, Du WW, Li H, Liu F, Khorshidi A, Rutnam ZJ and Yang BB: Both mature miR-17-5p and passenger strand miR-17-3p target TIMP3 and induce prostate tumor growth and invasion. *Nucleic Acids Res* 41: 9688-9704, 2013.
- Li Y, Vecchiarelli-Federico LM, Li YJ, Egan SE, Spaner D, Hough MR and Ben-David Y: The miR-17-92 cluster expands multipotent hematopoietic progenitors whereas imbalanced expression of its individual oncogenic miRNAs promotes leukemia in mice. *Blood* 119: 4486-4498, 2012.
- Shrivastava S, Petrone J, Steele R, Lauer GM, Di Bisceglie AM and Ray RB: Upregulation of circulating miR-20a is correlated with hepatitis C virus-mediated liver disease progression. *Hepatology* 58: 863-871, 2013.
- Zhou J, Jiang J, Wang S and Xia X: Oncogenic role of microRNA 20a in human uveal melanoma. *Mol Med Rep* 14: 1560-1566, 2016.
- Zhuo W, Ge W, Meng G, Jia S, Zhou X and Liu J: MicroRNA 20a promotes the proliferation and cell cycle of human osteosarcoma cells by suppressing early growth response 2 expression. *Mol Med Rep* 12: 4989-4994, 2015.
- Wang Z, Wang B, Shi Y, Xu C, Xiao HL, Ma LN, Xu SL, Yang L, Wang QL, Dang WQ, *et al*: Oncogenic miR-20a and miR-106a enhance the invasiveness of human glioma stem cells by directly targeting TIMP-2. *Oncogene* 34: 1407-1419, 2015.
- Xiong Y, Zhang L and Kebebew E: miR-20a is upregulated in anaplastic thyroid cancer and targets LIMK1. *PLoS One* 9: e96103, 2014.
- Landais S, Landry S, Legault P and Rassart E: Oncogenic potential of the miR-106-363 cluster and its implication in human T-cell leukemia. *Cancer Res* 67: 5699-5707, 2007.
- Li X, Zhang Z, Yu M, Li L, Du G, Xiao W and Yang H: Involvement of miR-20a in promoting gastric cancer progression by targeting early growth response 2 (EGR2). *Int J Mol Sci* 14: 16226-16239, 2013.
- Qiang XF, Zhang ZW, Liu Q, Sun N, Pan LL, Shen J, Li T, Yun C, Li H and Shi LH: miR-20a promotes prostate cancer invasion and migration through targeting ABL2. *J Cell Biochem* 115: 1269-1276, 2014.
- Olive V, Bennett MJ, Walker JC, Ma C, Jiang I, Cordon-Cardo C, Li QJ, Lowe SW, Hannon GJ and He L: miR-19 is a key oncogenic component of mir-17-92. *Genes Dev* 23: 2839-2849, 2009.
- Hsu TI, Hsu CH, Lee KH, Lin JT, Chen CS, Chang KC, Su CY, Hsiao M and Lu PJ: MicroRNA-18a is elevated in prostate cancer and promotes tumorigenesis through suppressing STK4 in vitro and in vivo. *Oncogenesis* 3: e99, 2014.

29. Niu H, Wang K, Zhang A, Yang S, Song Z, Wang W, Qian C, Li X, Zhu Y and Wang Y: miR-92a is a critical regulator of the apoptosis pathway in glioblastoma with inverse expression of BCL2L11. *Oncol Rep* 28: 1771-1777, 2012.
30. Tsuchida A, Ohno S, Wu W, Borjigin N, Fujita K, Aoki T, Ueda S, Takanashi M and Kuroda M: miR-92 is a key oncogenic component of the miR-17-92 cluster in colon cancer. *Cancer Sci* 102: 2264-2271, 2011.
31. Si H, Sun X, Chen Y, Cao Y, Chen S, Wang H and Hu C: Circulating microRNA-92a and microRNA-21 as novel minimally invasive biomarkers for primary breast cancer. *J Cancer Res Clin Oncol* 139: 223-229, 2013.
32. Santoro MM and Nicoli S: miRNAs in endothelial cell signaling: The endomiRNAs. *Exp Cell Res* 319: 1324-1330, 2013.
33. Doebele C, Bonauer A, Fischer A, Scholz A, Reiss Y, Urbich C, Hofmann WK, Zeiher AM and Dimmeler S: Members of the microRNA-17-92 cluster exhibit a cell-intrinsic angiogenic function in endothelial cells. *Blood* 115: 4944-4950, 2010.
34. Venturini L, Battmer K, Castoldi M, Schultheis B, Hochhaus A, Muckenthaler MU, Ganser A, Eder M and Scherr M: Expression of the miR-17-92 polycistron in chronic myeloid leukemia (CML) CD34⁺ cells. *Blood* 109: 4399-4405, 2007.
35. Shan SW, Lee DY, Deng Z, Shatseva T, Jeyapalan Z, Du WW, Zhang Y, Xuan JW, Yee SP, Siragam V, *et al*: MicroRNA miR-17 retards tissue growth and represses fibronectin expression. *Nat Cell Biol* 11: 1031-1038, 2009.
36. Li Y, Choi PS, Casey SC, Dill DL and Felsher DW: MYC through miR-17-92 suppresses specific target genes to maintain survival, autonomous proliferation, and a neoplastic state. *Cancer Cell* 26: 262-272, 2014.
37. Mestdagh P, Boström AK, Impens F, Fredlund E, Van Peer G, De Antonellis P, von Stedingk K, Ghesquière B, Schulte S, Dewes M, *et al*: The miR-17-92 microRNA cluster regulates multiple components of the TGF- β pathway in neuroblastoma. *Mol Cell* 40: 762-773, 2010.
38. Sokolova V, Fiorino A, Zoni E, Crippa E, Reid JF, Gariboldi M and Pierotti MA: The effects of miR-20a on p21: Two mechanisms blocking growth arrest in TGF β responsive colon carcinoma. *J Cell Physiol* 230: 3105-3114, 2015.
39. Woods K, Thomson JM and Hammond SM: Direct regulation of an oncogenic micro-RNA cluster by E2F transcription factors. *J Biol Chem* 282: 2130-2134, 2007.
40. O'Donnell KA, Wentzel EA, Zeller KI, Dang CV and Mendell JT: c-Myc-regulated microRNAs modulate E2F1 expression. *Nature* 435: 839-843, 2005.
41. Sylvestre Y, De Guire V, Querido E, Mukhopadhyay UK, Bourdeau V, Major F, Ferbeyre G and Chartrand P: An E2F/miR-20a autoregulatory feedback loop. *J Biol Chem* 282: 2135-2143, 2007.
42. Pichiorri F, Suh SS, Ladetto M, Kuehl M, Palumbo T, Drandi D, Taccioli C, Zanesi N, Alder H, Hagan JP, *et al*: MicroRNAs regulate critical genes associated with multiple myeloma pathogenesis. *Proc Natl Acad Sci USA* 105: 12885-12890, 2008.
43. Zhou P, Ma L, Zhou J, Jiang M, Rao E, Zhao Y and Guo F: miR-17-92 plays an oncogenic role and conveys chemo-resistance to cisplatin in human prostate cancer cells. *Int J Oncol* 48: 1737-1748, 2016.
44. Dou L, Meng X, Sui X, Wang S, Shen T, Huang X, Guo J, Fang W, Man Y, Xi J, *et al*: miR-19a regulates PTEN expression to mediate glycogen synthesis in hepatocytes. *Sci Rep* 5: 11602, 2015.
45. Takahashi RU, Miyazaki H and Ochiya T: The role of microRNAs in the regulation of cancer stem cells. *Front Genet* 4: 295, 2014.
46. Hwang WL, Jiang JK, Yang SH, Huang TS, Lan HY, Teng HW, Yang CY, Tsai YP, Lin CH, Wang HW, *et al*: MicroRNA-146a directs the symmetric division of Snail-dominant colorectal cancer stem cells. *Nat Cell Biol* 16: 268-280, 2014.
47. Zagorac S, Alcalá S, Fernandez Bayon G, Bou Kheir T, Schoenhals M, González-Neira A, Fernandez Fraga M, Aicher A, Heeschen C and Sainz B Jr: DNMT1 Inhibition reprograms pancreatic cancer stem cells via upregulation of the miR-17-92 cluster. *Cancer Res* 76: 4546-4558, 2016.
48. Cioffi M, Trabulo SM, Sanchez-Ripoll Y, Miranda-Lorenzo I, Lonardo E, Dorado J, Reis Vieira C, Ramirez JC, Hidalgo M, Aicher A, *et al*: The miR-17-92 cluster counteracts quiescence and chemoresistance in a distinct subpopulation of pancreatic cancer stem cells. *Gut* 64: 1936-1948, 2015.
49. He H and Magi-Galluzzi C: Epithelial-to-mesenchymal transition in renal neoplasms. *Adv Anat Pathol* 21: 174-180, 2014.
50. Kalluri R and Weinberg RA: The basics of epithelial-mesenchymal transition. *J Clin Invest* 119: 1420-1428, 2009.
51. Burk U, Schubert J, Wellner U, Schmalhofer O, Vincan E, Spaderna S and Brabletz T: A reciprocal repression between ZEB1 and member of the miR-200 family promotes EMT and invasion in cancer cells. *EMBO Rep* 9: 521-522, 2008.
52. Li J, Yang S, Yan W, Yang J, Qin YJ, Lin XL, Xie RY, Wang SC, Jin W, Gao F, *et al*: MicroRNA-19 triggers epithelial-mesenchymal transition of lung cancer cells accompanied by growth inhibition. *Lab Invest* 95: 1056-1070, 2015.
53. Xi XP, Zhuang J, Teng MJ, Xia LJ, Yang MY, Liu QG and Chen JB: MicroRNA-17 induces epithelial-mesenchymal transition consistent with the cancer stem cell phenotype by regulating CYP7B1 expression in colon cancer. *Int J Mol Med* 38: 499-506, 2016.
54. Ottman R, Levy J, Grizzle WE and Chakrabarti R: The other face of miR-17-92a cluster, exhibiting tumor suppressor effects in prostate cancer. *Oncotarget* 7: 73739-73753, 2016.
55. Wu Q, Yang Z, An Y, Hu H, Yin J, Zhang P, Nie Y, Wu K, Shi Y and Fan D: miR-19a/b modulate the metastasis of gastric cancer cells by targeting the tumour suppressor MXD1. *Cell Death Dis* 5: e1144, 2014.
56. Chen ZL, Zhao XH, Wang JW, Li BZ, Wang Z, Sun J, Tan FW, Ding DP, Xu XH, Zhou F, *et al*: microRNA-92a promotes lymph node metastasis of human esophageal squamous cell carcinoma via E-cadherin. *J Biol Chem* 286: 10725-10734, 2011.
57. Landskroner-Eiger S, Qiu C, Perrotta P, Siragusa M, Lee MY, Ulrich V, Luciano AK, Zhuang ZW, Corti F, Simons M, *et al*: Endothelial miR-17-92 cluster negatively regulates arteriogenesis via miRNA-19 repression of WNT signaling. *Proc Natl Acad Sci USA* 112: 12812-12817, 2015.
58. Ohyagi-Hara C, Sawada K, Kamiura S, Tomita Y, Isobe A, Hashimoto K, Kinose Y, Mabuchi S, Hisamatsu T, Takahashi T, *et al*: miR-92a inhibits peritoneal dissemination of ovarian cancer cells by inhibiting integrin $\alpha 5$ expression. *Am J Pathol* 182: 1876-1889, 2013.
59. Zhao S, Yao D, Chen J, Ding N and Ren F: miR-20a promotes cervical cancer proliferation and metastasis in vitro and in vivo. *PLoS One* 10: e0120905, 2015.
60. Zhang M, Liu Q, Mi S, Liang X, Zhang Z, Su X, Liu J, Chen Y, Wang M, Zhang Y, *et al*: Both miR-17-5p and miR-20a alleviate suppressive potential of myeloid-derived suppressor cells by modulating STAT3 expression. *J Immunol* 186: 4716-4724, 2011.
61. Dereani S, Macor P, D'Agaro T, Mezzaroba N, Dal-Bo M, Capolla S, Zucchetto A, Tissino E, Del Poeta G, Zorzet S, *et al*: Potential therapeutic role of antagonism of miR17 for the treatment of chronic lymphocytic leukemia. *J Hematol Oncol* 7: 79, 2014.
62. Murphy BL, Obad S, Bihannic L, Ayrault O, Zindy F, Kauppinen S and Roussel MF: Silencing of the miR-17-92 cluster family inhibits medulloblastoma progression. *Cancer Res* 73: 7068-7078, 2013.
63. Chen J, Huang ZP, Seok HY, Ding J, Kataoka M, Zhang Z, Hu X, Wang G, Lin Z, Wang S, *et al*: miR-17-92 cluster is required for and sufficient to induce cardiomyocyte proliferation in postnatal and adult hearts. *Circ Res* 112: 1557-1566, 2013.
64. Zhou T, Zhang G, Liu Z, Xia S and Tian H: Overexpression of miR-92a correlates with tumor metastasis and poor prognosis in patients with colorectal cancer. *Int J Colorectal Dis* 28: 19-24, 2013.



This work is licensed under a Creative Commons Attribution-NonCommercial-NoDerivatives 4.0 International (CC BY-NC-ND 4.0) License.