

FoxK mediates TGF- β signalling during midgut differentiation in flies

Sergio Casas-Tinto,^{1,2} Melisa Gomez-Velazquez,¹ Begoña Granadino,² and Pedro Fernandez-Funez¹

¹Department of Neurology, University of Texas Medical Branch, Galveston, TX 77555

²Centro de Investigaciones Biológicas, Consejo Superior de Investigaciones Científicas, 28040 Madrid, Spain

Inductive signals across germ layers are important for the development of the endoderm in vertebrates and invertebrates (Tam, P.P., M. Kanai-Azuma, and Y. Kanai. 2003. *Curr. Opin. Genet. Dev.* 13:393–400; Nakagoshi, H. 2005. *Dev. Growth Differ.* 47:383–392). In flies, the visceral mesoderm secretes signaling molecules that diffuse into the underlying midgut endoderm, where conserved signaling cascades activate the Hox gene *labial*, which is important for the differentiation of copper cells (Bienz, M. 1997. *Curr. Opin. Genet. Dev.* 7:683–688). We present here a *Drosophila melanogaster* gene of the Fox family of transcription factors, *FoxK*, that mediates transforming growth factor β (TGF- β) signaling in the em-

bryonic midgut endoderm. *FoxK* mutant embryos fail to generate midgut constrictions and lack *Labial* in the endoderm. Our observations suggest that TGF- β signaling directly regulates *FoxK* through functional Smad/Mad-binding sites, whereas *FoxK*, in turn, regulates *labial* expression. We also describe a new cooperative activity of the transcription factors *FoxK* and *Dfos/AP-1* that regulates *labial* expression in the midgut endoderm. This regulatory activity does not require direct *labial* activation by the TGF- β effector *Mad*. Thus, we propose that the combined activity of the TGF- β target genes *FoxK* and *Dfos* is critical for the direct activation of *lab* in the endoderm.

Introduction

The differentiation of the midgut endoderm in *Drosophila melanogaster* is mediated by extracellular signals released by the adhering visceral mesoderm (for reviews see Bienz, 1997; Nakagoshi, 2005). By stage 16, the visceral mesoderm surrounding the endodermal tube induces the subdivision of the midgut endoderm along its anterior–posterior axis. This process is regulated by the selective and nonoverlapping expression of the four posterior *Hox* genes in the visceral mesoderm (for review see Bienz, 1997; Miller et al., 2001). The *Hox* genes regulate the expression of signaling molecules such as decapentaplegic (*Dpp*), a member of the TGF- β superfamily, and *Wingless/Wnt* (*Wg*) in the visceral mesoderm (Immergluck et al., 1990; Reuter and Scott, 1990). *Dpp* and *Wg* maintain each other's expression and also regulate the expression of a ligand for the EGF receptor, *Vein*, in the visceral mesoderm. These three signaling molecules diffuse into the underlying endoderm to induce morphogenetic events

critical for the functional organization of the midgut (Immergluck et al., 1990; Panganiban et al., 1990; Reuter et al., 1990).

The regulatory events necessary for the specification and differentiation of parasegment 7 are the best documented. The sequence of events involves: (a) *Dpp*, *Wg*, and *Vein* signaling from the neighboring visceral mesoderm into the underlying midgut endoderm, (b) activation of known intracellular and nuclear effectors of the *Dpp*, *Wg*, and EGF receptor pathways in the endoderm layer, and, lastly, (c) expression of *labial* (*lab*) in parasegment 7 of the endoderm, a *Hox* gene required for endoderm differentiation (Immergluck et al., 1990; Panganiban et al., 1990; Reuter et al., 1990). *Defective proventriculus* and *Teashirt* (*Tsh*) are two additional transcription factors that respond to *Dpp* and *Wg* signaling in the endoderm. *Tsh* negatively regulates *lab* and is required for interstitial cell precursors (Mathies et al., 1994), whereas *Defective proventriculus* is broadly expressed in midgut precursor cells and is later repressed by *lab* (Nakagoshi et al., 1998). Importantly, the inductive processes

Correspondence to Sergio Casas-Tinto: scasas@cniio.es; or Pedro Fernandez-Funez: pefernan@utmb.edu

Abbreviations used in this paper: *Dpp*, decapentaplegic; EMSA, electrophoretic mobility shift assay; FH, fork head; FHA, FH-associated domain; Fox, fork head Box; ILF, interleukin factor; lab, labial; MAD, Mothers against dpp; MNF, myocyte nuclear factor; ORF, open reading frame; pSmad, phosphorylated Smad; S2, *Drosophila* Schneider 2; tkv, thickveins; Tsh, Teashirt; Wg, Wingless/Wnt.

© 2008 Casas-Tinto et al. This article is distributed under the terms of an Attribution–Noncommercial–Share Alike–No Mirror Sites license for the first six months after the publication date [see <http://www.jcb.org/misc/terms.shtml>]. After six months it is available under a Creative Commons License [Attribution–Noncommercial–Share Alike 3.0 Unported license, as described at <http://creativecommons.org/licenses/by-nc-sa/3.0/>].

Figure 1. Peptidic sequence and genomic structure of *Drosophila* FoxK. (A) Sequence alignment of the FH domains of *Drosophila* FoxK, human ILF, and murine MNF. Identical and conserved amino acids are indicated in black shading. The bipartite nuclear localization sequence (NLS) is indicated in red. The three α helices (H1–3) and the two winged loops (W1 and 2) are also indicated. (B) Amino acid conservation between full-length FoxK and human ILF. Conservation in the FHA and FH domains is indicated. (C) Full-length amino acid sequence of FoxK-L. The FHA and FH domains (both in red) are indicated (FH underlined). Sequence encoded by the alternatively spliced exons 8 and 9 absent in FoxK-S is shown in green. (D) Exon/intron structure of FoxK with the four alternative 5'UTRs (black boxes). The coding region of FoxK extends from exon 2 (ATG) to exon 9 (TGA). The FHA and FH domains are indicated. (E) Structure of FoxK-L transcripts. The hypothetical FoxK-L-RE mRNA lacks part of exon 6. (F) Structure of the FoxK-S transcripts. An alternative splicing that lacks 258 nucleotides between exons 8 and 9 (C and D, green) generates four different FoxK-S mRNAs.

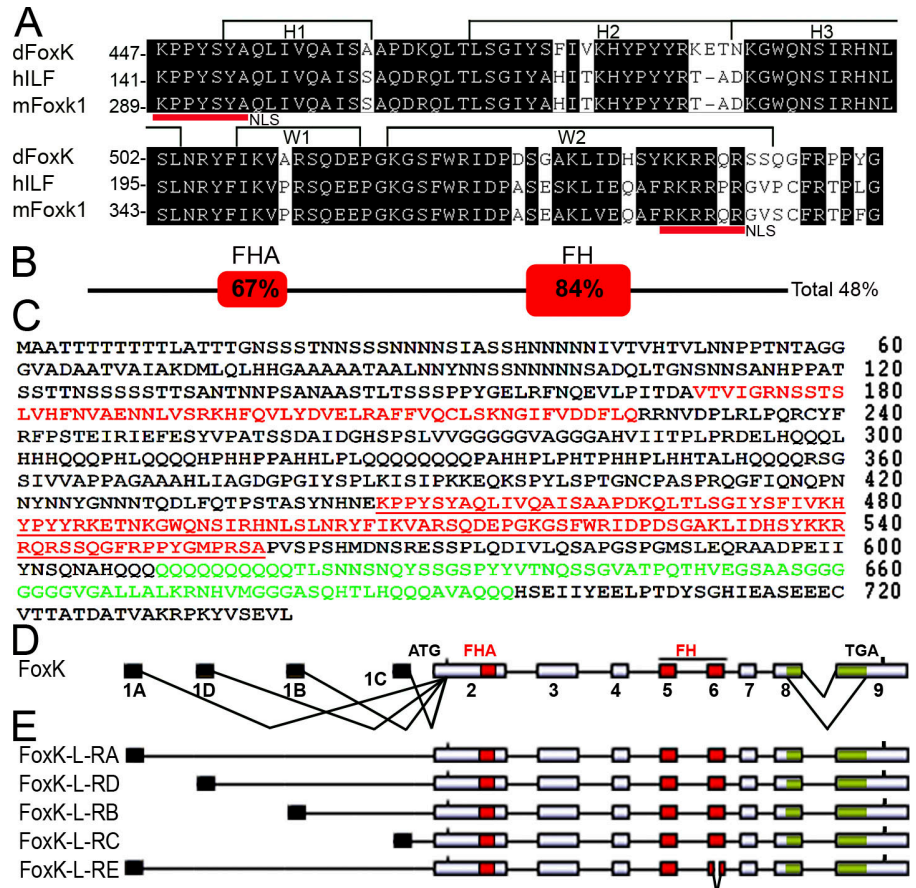

across germ layers mediated by the TGF- β and Wnt pathways are conserved mechanisms during specification and differentiation of the endoderm layer in vertebrates (Tam et al., 2003).

The activity of Dpp in the visceral mesoderm induces a well known signaling cascade that leads to phosphorylation of the Smad protein Mothers against dpp (Mad) and nuclear translocation of Med (Mad–Medea) complexes (for review see Bienz, 1997; Massague and Wotton, 2000). The active Mad–Med complexes regulate the expression of specific targets, such as the transcription factors Lab and Dfos/AP-1 in midgut endoderm. Dfos is required, but not sufficient, to activate *lab* expression in the endoderm, suggesting that Dfos is a component of a transcriptional complex that regulates Lab expression and midgut specification (Riese et al., 1997). It is unclear at this time how the reiterated use of Mad in different developmental contexts results in the activation of unique, tissue-specific developmental programs. In particular, how does Mad precisely activate *lab* in the endoderm? What other factors contribute to the tissue-specific activity of Mad?

The fork head box (Fox) protein family is comprised of transcription factors that share a structurally related DNA-binding domain, the fork head (FH) or winged helix domain (Weigel and Jackle, 1990). Of the 17 *Drosophila* genes encoding for Fox proteins, only 7 have been functionally characterized (Lee and Frasch, 2004). To learn more about the function of Fox proteins in development, we concentrated on the *Drosophila* orthologue of vertebrate FOXK1, also known as myo-

cyte nuclear factor (MNF) in mice and interleukin factor (ILF) in humans (Li et al., 1991; Bassel-Duby et al., 1994). Lee and Frasch (2004) described *Drosophila* FOXK1 previously, but it is currently identified as MNF in FlyBase (<http://flybase.org/reports/FBgn0036134.html>). To follow modern nomenclature, we will refer to *Drosophila* MNF as FoxK. In the present work, we characterized the function of FoxK during midgut development and found that FoxK is required for Lab expression and for the formation of the midgut constrictions. Moreover, we describe a novel cooperative activity between the transcription factors FoxK and Dfos/AP-1 that mediate the Dpp signaling events during endoderm differentiation. Thus, FoxK plays a critical role in a key inductive process during midgut development.

Results

Sequence conservation and genomic structure of *Drosophila* FoxK

Our study of the *Drosophila* orthologue of FOXK1 determined that its FH domain shares 84% sequence conservation to both human and murine FOXK1 and contains a characteristic bipartite nuclear localization sequence (Fig. 1, A and B). The N-terminal portion of *Drosophila* FoxK also contains a conserved FH-associated domain (FHA; Fig. 1, B and C), a phosphoprotein-binding domain typically found in the FOXK subfamily and in other proteins (Durocher and Jackson, 2002). *Drosophila* FoxK

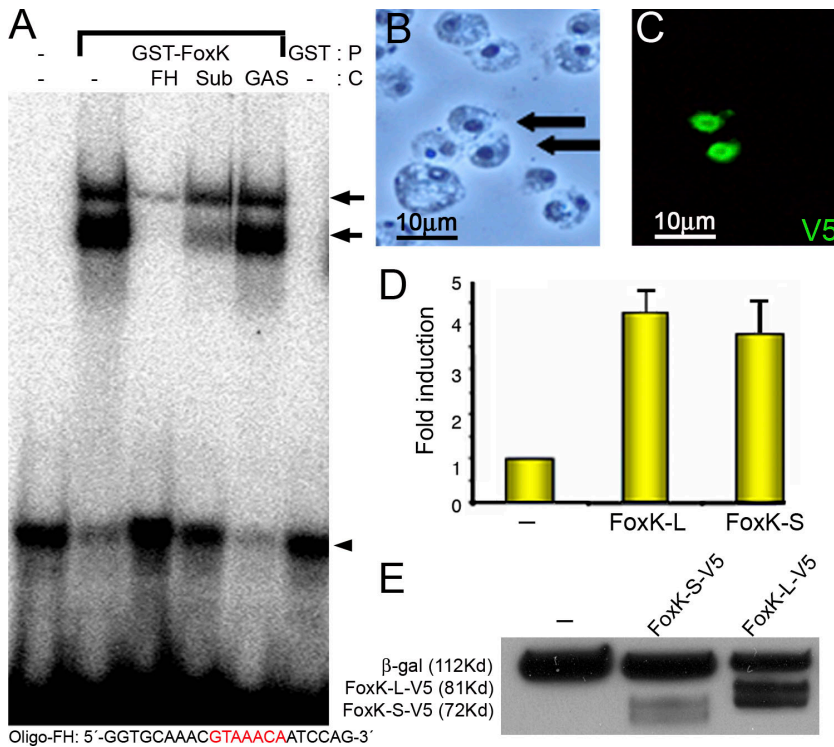

Figure 2. FoxK binds to specific DNA sequences and regulates transcription. (A) EMSA performed with GST-FoxK(414–654) or GST alone (protein [P]) and the radiolabeled double-stranded oligonucleotide Oligo-FH containing an optimum FH-binding site (red). Cold Oligo-FH probe (FH), a suboptimum FH-binding site (Sub), and an unrelated sequence (GAS) were used at 100-fold molar excess (competitors [C]). The higher bands (arrows) indicate specific binding of FoxK to Oligo-FH. Cold Oligo-FH efficiently competes for FoxK, whereas a suboptimum FH-binding site is a less efficient competitor and GAS does not compete for FoxK. GST alone did not bind to Oligo-FH. Free oligonucleotides complexes accumulate in the bottom (arrowhead). (B and C) A plasmid driving luciferase under the control of six consecutive Oligo-FH sequences (6xFH) was cotransfected with *pAc5C-FoxK-L-V5*, *pAc5C-FoxK-S-V5*, or empty vector in S2 cells. As expected, both FoxK-L and FoxK-S isoforms exhibit nuclear localization in transfected S2 cells (green, FoxK-L-V5). (D) Both FoxK-L and FoxK-S induce a four-fold activation of the 6xFH target sequence. The error bars correspond to the standard deviation of three independent experiments. (E) The FoxK-L and FoxK-S proteins migrate in two distinct bands in Western blot, suggesting posttranslational modification. β-Galactosidase was used for normalization.

shares 67% identity in the FHA domain with human ILF/FOXK1, whereas the overall conservation of the full-length sequence is 48% (Fig. 1 B).

The *FoxK* locus spans 6,482 bp, containing four alternative 5'UTRs and nine exons according to the Berkeley Drosophila Genome Project. Five computer-predicted cDNAs contained *FoxK* sequences (Fig. 1 D). Four of these transcripts only differ in their 5'UTR: *FoxK-RA* (3,231 bp), *FoxK-RD* (3,195 bp), *FoxK-RB* (3,320 bp), and *FoxK-RC* (3,117 bp) (Fig. 1 E). ESTs from the Berkeley Drosophila Genome Project supported the existence of all these alternative transcripts. These four transcripts generated the same open reading frame (ORF) of 2,220 nucleotides encoding a 740-amino acid long polypeptide (termed FoxK-L; Fig. 1 C). The exon/intron structure of *FoxK* was confirmed by RT-PCR with specific primers for each exon (unpublished data).

The predicted *FoxK-L-RE* transcript (3,108 bp) shared the 5'UTR with *FoxK-RA*, but exon 6 seemed to split in two exons (Fig. 1 E). This alternative splicing should preserve the reading frame of the amino acid sequence, resulting in a protein lacking 41 amino acids in the W2 domain of the FH domain. The single EST supporting the existence of *FoxK-RE* (LD16137), although similar to the predicted *FoxK-RE* isoform, had 16 extra nucleotides in exon 6, which would produce a frame shift and a premature Stop codon. Our RT-PCR experiments failed to provide experimental evidence for the *FoxK-RE* transcript, but its existence could not be ruled out.

While sequencing the RT-PCR products from all *FoxK* exons, we noticed a novel alternative splicing between exons 8 and 9 (Fig. 1 F). These transcripts generated an ORF of 1,962 nucleotides encoding a 654-amino acid short polypeptide (termed FoxK-S; Fig. 1 F). *FoxK-S* RNA lacked 258 nucleotides

from exons 8 and 9 corresponding to 86 amino acids that preserved the reading frame of FoxK-L (Fig. 1 C, green).

Transcriptional activity of FoxK protein

To determine the transcriptional activity of this putative transcription factor, we first assayed its ability to bind specific DNA sequences. Mouse MNF/FOXK1 binds both strands of the consensus FH-binding site composed of the heptanucleotide core 5'-(A/G)TAAA(C/T)A-3' (Weigel and Jackle, 1990; Granadino et al., 2000). Electrophoretic mobility shift assays (EMSA) performed with a recombinant fusion protein including the FH domain of FoxK (GST-FoxK[414–654]) and a radiolabeled oligonucleotide probe containing a consensus FH-binding site (Oligo-FH) produced high molecular mass complexes (Fig. 2 A, arrows). The addition of cold Oligo-FH efficiently displaced the labeled probe, whereas a suboptimal probe (Fig. 2 A, Sub) was less efficient. Conversely, an unrelated oligonucleotide (Fig. 2 A, GAS) did not interfere with Oligo-FH binding. Together, these results showed that the FH domain of FoxK specifically recognized a DNA sequence carrying a consensus FH-binding site.

Next, we evaluated the transcriptional activity of the two FoxK isoforms in transactivation assays in *Drosophila* Schneider 2 (S2) cells. Expression of V5-tagged FoxK-S or FoxK-L resulted in nuclear accumulation of FoxK, confirming the functionality of the bipartite nuclear localization sequence (Fig. 2, B and C). S2 cells were next cotransfected with *FoxK* constructs and a luciferase-based reporter gene under the control of six tandem copies of Oligo-FH (6xFH). Despite the differences in the N-terminal region, FoxK-S and FoxK-L induced similar transcriptional activation on the reporter construct (Fig. 2 D). Interestingly, protein extracts from S2 cells transfected with *FoxK-S* and *FoxK-L* constructs produced two distinct bands in

Figure 3. Distribution of FoxK in *Drosophila* embryos. (A and B) Distinct temporal accumulation of the *FoxK-L* and *FoxK-S* transcripts by RT-PCR. *FoxK-L* is present in unfertilized embryos (UE), pupae (P), and head (H) and in thorax (T) and abdomen (Ab) from adult flies (A). *FoxK-S* accumulates in embryos (E) and salivary glands (SG) and gut from larvae (L). (C and D) In situ hybridization of wild-type embryos using digoxigenin-labeled *FoxK*-mRNA probes. In stage 16 embryos, the sense probe results in negative signal (C), whereas *FoxK* mRNA accumulates in the endoderm of parasegments (PS) 3 and 7 (D). (E and F) Single focal plane of whole-mount wild-type embryos stained with anti-FoxK antibody. (E) Stage 15 embryos revealed nuclear FoxK signal in the lining of the single vesicle of the midgut endoderm (arrow). (F) Stage 16 embryos accumulate FoxK in the lining of all four vesicles of the midgut endoderm and gastric constrictions (arrow). (G) Ventral view of an embryo showing FoxK (green) expression along the ventral nerve cord also labeled with anti-Elav (merged image). (H and I) Detail of G showing FoxK and Elav colocalization in the nuclei of ventral cord neurons (H, merge) or FoxK alone (I). All embryos are oriented with the anterior end to the left.

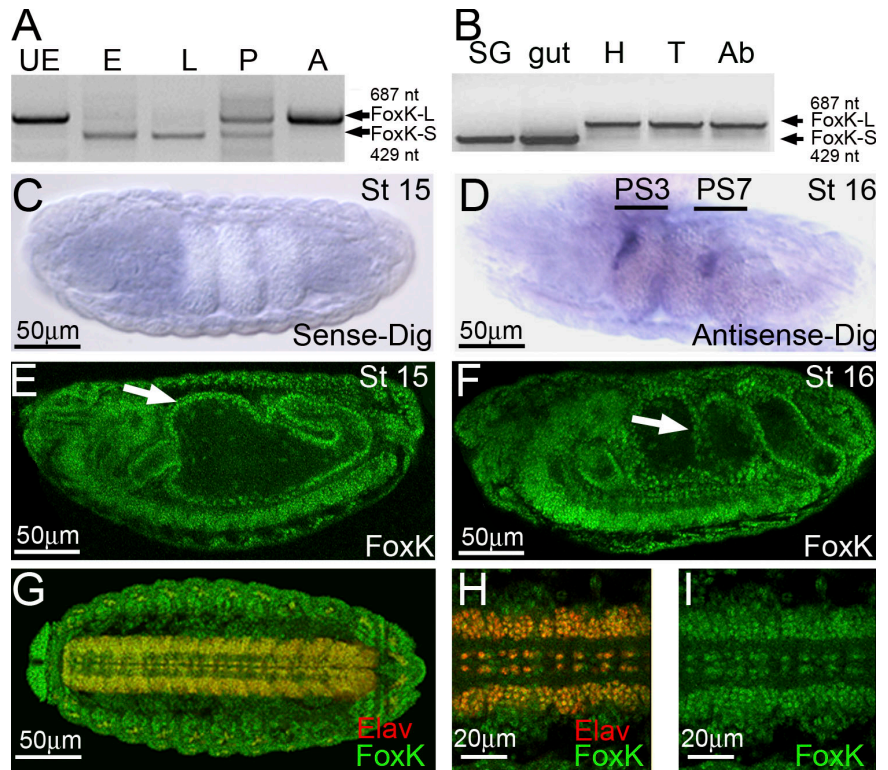

Western blot. The lower band had the expected molecular mass, whereas the higher band suggested the posttranslational modification of FoxK (Fig. 2 E). It has been shown previously that mammalian FOXK1 is phosphorylated (Yang et al., 1997) and *Drosophila* FoxK contains multiple putative phosphorylation domains. However, we could not dephosphorylate FoxK in protein extracts using three potent and general phosphatases (see Materials and methods; unpublished data). Therefore, other mechanisms should be responsible for the posttranslational modification of FoxK. Overall, these observations indicated that both FoxK-S and FoxK-L induced potent transcriptional activation upon interaction with specific DNA sequences containing consensus FH-binding sites.

FoxK expression in the *Drosophila* embryo

Using oligonucleotide primers specific for different exons of the *FoxK* gene, we detected *FoxK* transcripts at all stages of *Drosophila* development (Fig. 3 A). Interestingly, we found a prominent temporal distribution of the *FoxK-S* and *FoxK-L* transcripts, whereas *FoxK-S* was predominantly expressed during the embryonic and larval stages, *FoxK-L* was mainly seen in pupae, adults, and unfertilized eggs. Moreover, *FoxK* transcripts were detected in all tissues analyzed: larval salivary glands and gut and adult head, thorax, and abdomen (Fig. 3 B).

Previously reported in situ hybridizations showed that *FoxK* mRNA is found at high levels in preblastoderm embryos and that uniform *FoxK* mRNA distribution in embryos persisted until embryonic stage 13 (Lee and Frasch, 2004). Later on, *FoxK* mRNA levels declined in all tissues except for the central nervous system. We confirmed these published observations and also found that *FoxK* mRNA localized to the midgut endo-

derm in stage 15 and 16 embryos (Fig. 3, C and D). To support the distribution of *FoxK* transcripts, we generated and purified a polyclonal antiserum against the central region of FoxK. Immunohistochemical analysis with this specific antibody confirmed that FoxK protein is expressed in a single layer of cells in the midgut endoderm in stage 14–15 embryos (Fig. 3 E). Stage 16 embryos showed accumulation of FoxK protein in the endodermal cells of the midgut, including the constrictions (Fig. 3 F). FoxK antiserum also stained the nuclei of neurons of the ventral nerve cord in stage 14–17 embryos (Fig. 3, G–I) and epidermal cells in the lateral ectoderm (not depicted).

Generation and analysis of *FoxK* mutant alleles

To elucidate the function of *FoxK* in *Drosophila*, we generated *FoxK* loss-of-function alleles by imprecise excision of a *P* element inserted 676 bp upstream of the ATG for *FoxK* (Fig. 4 A). We recovered two *FoxK* mutant alleles that resulted in recessive lethal chromosomes. To ensure that the lethality of the *FoxK* alleles was contained in the *FoxK* region, we confirmed that a chromosomal duplication of *FoxK* recovered the viability of *FoxK¹⁶* and *FoxK⁴⁴* homozygous flies. To molecularly characterize these new *FoxK* alleles, we analyzed genomic DNA from *FoxK¹⁶* and *FoxK⁴⁴* flies by Southern blot with a probe covering the entire *FoxK* coding region. DNA samples from *FoxK¹⁶* and *FoxK⁴⁴* heterozygous flies showed an unexpected band suggestive of a chromosomal aberration within *FoxK* (Fig. 4 C, arrow). To delimitate the affected region, we sequenced the central region of *FoxK* using specific primers for exons 3–5 (Fig. 4 A, red arrowheads). We confirmed that *FoxK⁴⁴* contains a partial reinsertion of the *P* element in exon 3, creating a Stop codon 28

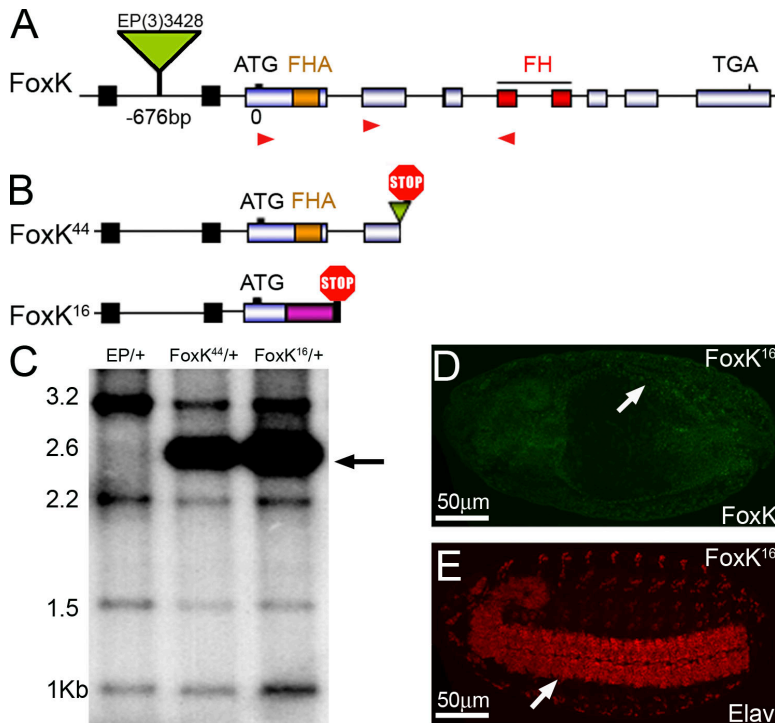

Figure 4. Molecular characterization of FoxK mutant alleles. (A) The P element EP(3)3428 is inserted in 676 bp 5' of the ATG (0) of FoxK. Red arrowheads indicate the primers used for sequencing exons 2–5. (B) Both FoxK⁴⁴ and FoxK¹⁶ carry a deletion of 2 bp at the insertion site of EP(3)3428 (–676ΔTA). FoxK⁴⁴ flies also contain a reinsertion of a fragment of the P element in exon 3 (green) that generates a premature Stop codon. In FoxK¹⁶, a deletion in exon 2 generates a new ORF (purple) containing a Stop codon. (C) Southern blot hybridized with a probe covering the entire FoxK coding region shows an extra band of 2.6 Kb in FoxK⁴⁴ and FoxK¹⁶ (arrow). (D and E) Stage 15 FoxK¹⁶ homozygous embryos do not stain with anti-FoxK (D, arrow), but the ventral nerve cord stains with anti-Elav and shows normal morphology (E, arrow).

nucleotides after the insertion (Fig. 4 B). The truncated protein produced by FoxK⁴⁴ retained the FHA domain, but lacked the FH domain. Next, to identify the molecular changes associated with FoxK¹⁶, we sequenced exons 2–5 and identified a deficiency of 962 bp affecting exons 2 and 3 (Fig. 4 B). Four extra nucleotides (TCTG) in the 3' sequence adjacent to the deficiency changed the ORF. Consequently, FoxK¹⁶ encoded for a chimeric polypeptide that shared the first 26 amino acids with FoxK, but the predicted new frame eliminated both the FH and FHA domains and introduced 66 new amino acids (Fig. 4 B).

Based on the molecular data, both FoxK¹⁶ and FoxK⁴⁴ should result in negative immunoreaction with the anti-FoxK antibody. To confirm this, we stained embryos homozygous for FoxK⁴⁴ and FoxK¹⁶ with the anti-FoxK antibody. As predicted, neither FoxK⁴⁴ nor FoxK¹⁶ mutant embryos produced immunoreactivity to anti-FoxK antibody (Fig. 4 D, only FoxK¹⁶ is shown), whereas heterozygous sibling embryos positively reacted to anti-FoxK. To ensure that the negatively stained embryos developed properly, the nerve cord was stained to reveal the accumulation of the panneuronal marker Elav (Fig. 4 E). Therefore, the lack of anti-FoxK staining in FoxK⁴⁴ and FoxK¹⁶ homozygous embryos indicated that both are null FoxK alleles.

FoxK is required for midgut constrictions

To determine the reason for the lethality of the FoxK alleles, we analyzed the development of FoxK¹⁶ homozygous embryos at different stages. Although FoxK presented a widespread distribution in developing embryos, we found no obvious morphological abnormalities in early and intermediate stages of development. However, midgut differentiation was abnormal in late FoxK mutant embryos. Early midgut development was normal in both FoxK¹⁶ and FoxK⁴⁴ mutant embryos until stage 15, when the midgut was comprised of a single vesicle (Fig. 5, A–C, dashed line).

During stage 16 three constrictions generated the four vesicles of the normal midgut (Fig. 5 D). However, FoxK⁴⁴ homozygous embryos formed a single midgut constriction and two gastric vesicles (Fig. 5 E), whereas FoxK¹⁶ embryos failed to complete the first midgut constriction (Fig. 5 F). Later on, wild-type embryos formed the mature midgut compartments in stage 17 (Fig. 5 G), but the midgut did not further develop in either FoxK⁴⁴ or FoxK¹⁶ homozygous embryos (Fig. 5, H and I). Thus, FoxK activity is required for the formation of the midgut constrictions and for the proper development of the midgut vesicles.

Intrigued by the lack of early phenotypes associated to the widespread distribution of FoxK, we explored the possibility that early FoxK activity could be provided maternally. In fact, FoxK transcripts are highly expressed in unfertilized eggs (Fig. 3 A). To assess the maternal contribution of FoxK activity, we obtained a FoxK-RNAi (FoxKi) construct under the control of UAS sequences. Embryos lacking maternal FoxK activity were morphologically deformed (Fig. 5, J–L). Most embryos stopped developing around stage 13, after germ band retraction, and showed dramatic alteration of the segmental expression of the Hox protein Engrailed (Fig. 5, M–O). These defects induced by the maternally expressed FoxKi suggested that FoxK is required for key processes regulating early segmentation. To further understand the function of FoxK, we concentrated on its zygotic requirement in the midgut.

FoxK is required for Lab expression in endoderm

Previous studies demonstrated the importance of lab in midgut endoderm: lab is expressed in the endoderm under the control of Dpp signaling and is required for copper cell identity and function (Immergluck et al., 1990; Panganiban et al., 1990; Reuter et al., 1990). The distribution of Lab in the midgut endoderm

Figure 5. Zygotic FoxK activity is necessary for midgut differentiation. Midgut development in wild-type (A, D, and G), *FoxK⁴⁴* (B, E, and H), and *FoxK¹⁶* (C, F, and I) embryos. In *FoxK⁴⁴* and *FoxK¹⁶* homozygous embryos, the single vesicle of the midgut develops normally until stage 15 (A–C, dashed lines). During stages 16 and 17, wild-type embryos develop four vesicles after the formation of the midgut constrictions (D and G, arrowheads). However, *FoxK⁴⁴* homozygous embryos only develop one midgut constriction (E and H, arrowheads), whereas *FoxK¹⁶* embryos never develop midgut constrictions (F and I). (J–O) Maternal FoxK is critical for early embryonic development. Differential interference contrast (J–L) and confocal images showing Engrailed (En) expression (M–O) of a normal embryo (J and M) and two different embryos expressing FoxKi under a maternally expressed Gal4-VP16 fusion (*tub-Gal4-VP16/UAS-Foxki*). The segmental Engrailed stripes are fused (N, arrowhead), split (N and O, arrows), and generally disorganized along the anteroposterior axis.

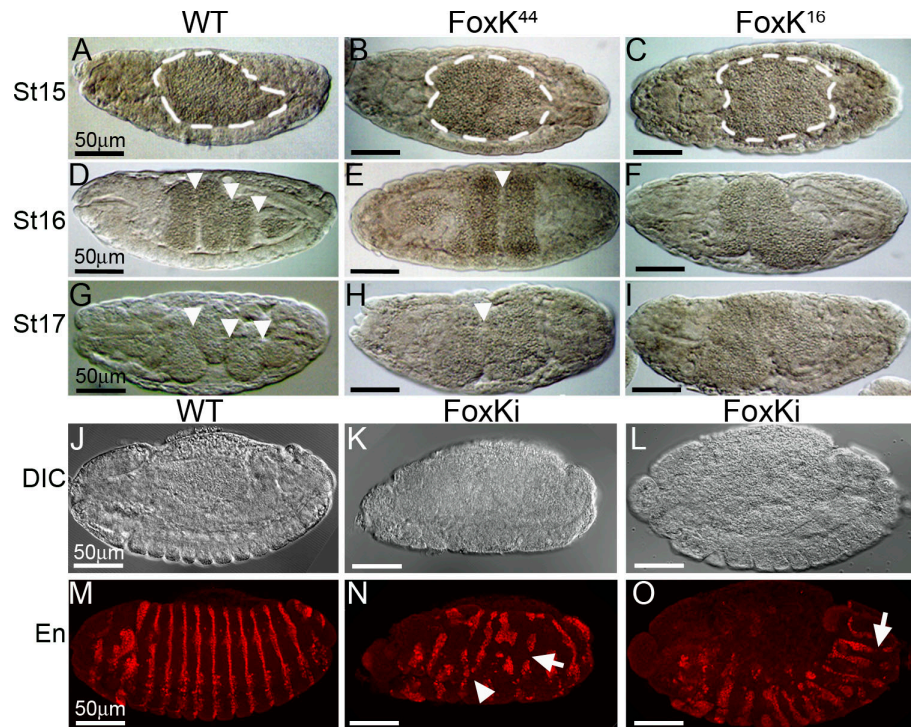

overlaps with FoxK in parasegment 7 (Fig. 6, A and B), suggesting a potential functional relationship between these two proteins. We found that *FoxK* mutant embryos lacked Lab in the endoderm (Fig. 6 C), suggesting that *lab* expression depends on *FoxK* activity in the midgut endoderm. To confirm this result, we specifically eliminated *FoxK* activity in the endoderm by expressing the *FoxKi* silencing construct. These embryos also exhibited incomplete midgut development and loss of Lab expression (Fig. 6, E and F). These results confirmed that *FoxK* activity is essential for *lab* expression in the endoderm. Next, we examined whether *FoxK* overexpression in the endoderm could induce ectopic Lab accumulation; however, Lab expression was normal in these embryos (Fig. 6, G–I). These observations argue that *FoxK* is required, but not sufficient, to specifically activate *lab* in the endoderm. Moreover, we found no changes in Tsh expression in embryos carrying *FoxK* mutant alleles or *FoxK* overexpression (unpublished data).

To support a direct regulation of *lab* by FoxK, we searched the *lab* promoter region for putative FH-binding sites. To our surprise, we identified 19 consensus FH-binding sites in a region spanning 6.3 Kb upstream of *lab* (Fig. 6 J). In fact, 6 of the 19 putative FH-binding sites contained the sequence 5'-ATAAATA-3' (Fig. 6 J, black circles), which strongly and specifically interacted with FoxK in EMSA (Fig. 6 K). Interestingly, no FH-binding sites were found in the minimal *lab* enhancer *lab550* (Fig. 6 J). To test the functional relevance of the FH-binding sites identified in the *lab* promoter, we assayed the transcriptional activity of a 678-bp element containing five FH-binding sites, including two with the sequence 5'-ATAAATA-3' (Fig. 6 J). This *lab678* element responded to both FoxK-S and FoxK-L by inducing 3.5-fold expression of luciferase in transactivation assays (Fig. 6 L). This result suggested that FoxK can directly regulate *lab* expression through the FH-binding sites identified

in the *lab* locus in concert with other Dpp-dependent transcription factors.

Dpp directly regulates FoxK expression in midgut endoderm

Because both FoxK and Dpp regulate *lab* in the midgut and their loss-of-function leads to midgut developmental arrest, we investigated the functional interaction between *dpp* and *FoxK*. First, we generated double heterozygous combinations *dpp^{+/-}; FoxK^{+/-}* and found that the combinations with strong *dpp* alleles resulted in synthetic lethality, supporting the functional interaction between *dpp* and *FoxK* (Fig. 7 A). Next, we asked whether *FoxK* functioned under the control of the Dpp signaling cascade in midgut endoderm. As shown previously (Staebling-Hampton and Hoffmann, 1994), ectopic expression of *dpp* in the visceral mesoderm leads to ectopic Lab accumulation in the endoderm (Fig. 7, B and D) and also resulted in increased levels of *FoxK* in the endoderm (Fig. 7, C and E). Conversely, embryos overexpressing a dominant-negative form of the Dpp type I receptor *thickveins* (*tkv^{DN}*) in the endoderm showed low levels of both Lab and FoxK in the endoderm (Fig. 7, H and I). Collectively, these observations suggested that Dpp activity in the visceral mesoderm regulates *FoxK* expression in the adjacent midgut endoderm.

It has been postulated that Mad directly regulates *lab* expression in the endoderm in response to Dpp signaling (Szuts and Bienz, 2000; Marty et al., 2001). However, the loss of Lab in *FoxK* and *Dfos* loss-of-function alleles suggested that *lab* regulation requires additional factors that mediate Dpp activity in midgut endoderm. To investigate the role of FoxK in the regulation of *lab*, we analyzed Lab accumulation in *FoxK¹⁶* mutant embryos that also overexpressed *dpp*. These embryos lacked Lab in the midgut endoderm even though they expressed high levels of Dpp (Fig. 7, J–L). Because ectopic Mad activation

Figure 7. Dpp directly regulates FoxK in the endoderm. (A) Transheterozygous combinations of *dpp*^{+/-} and *FoxK*^{+/-} mutant alleles result in lethality. (B and C) A control embryo (stage 15) shows normal Lab (arrowhead) and FoxK (green; arrows) accumulation in the endoderm. (D–F) *dpp* overexpression in the visceral mesoderm (*24B-Gal4*) induces ectopic Lab (arrowhead) and FoxK (arrow) in the endoderm. Merged panel is shown in F. (G–I) Expression of *tkv*^{DN} in the endoderm (*48Y-Gal4*) eliminates both Lab (arrowhead) and FoxK (arrow) in the endoderm. Merged panel is shown in I. (J–L) Homozygous *FoxK*¹⁶ embryos that also overexpress *dpp* in the visceral mesoderm lack Lab expression in the endoderm (arrowhead). K shows negative FoxK staining and the merged image is in L. (M) EMSA performed with a genomic-derived probe (Oligo-Mad) containing multiple Mad-binding sites (right) and protein extracts from S2 cells transfected with combinations of *Mad*, *Med*, and *tkv*^{act} constructs. The cellular extracts from nontransfected cells (S2) or cells transfected with *Mad* and *Med* constructs resulted in a small shift of the Oligo-Mad (arrow). Extracts expressing *tkv*^{act} produced a stronger binding, but extracts expressing all three constructs resulted in the strongest binding to the Oligo-Mad probe. The lanes with no cell extract (-) and the use of an unspecific probe (GAS) produced no shift. The free oligonucleotides and oligonucleotide complexes are indicated by the arrowhead. (N) The *24B-Gal4* strain induces GFP expression in the mesoderm (arrow).

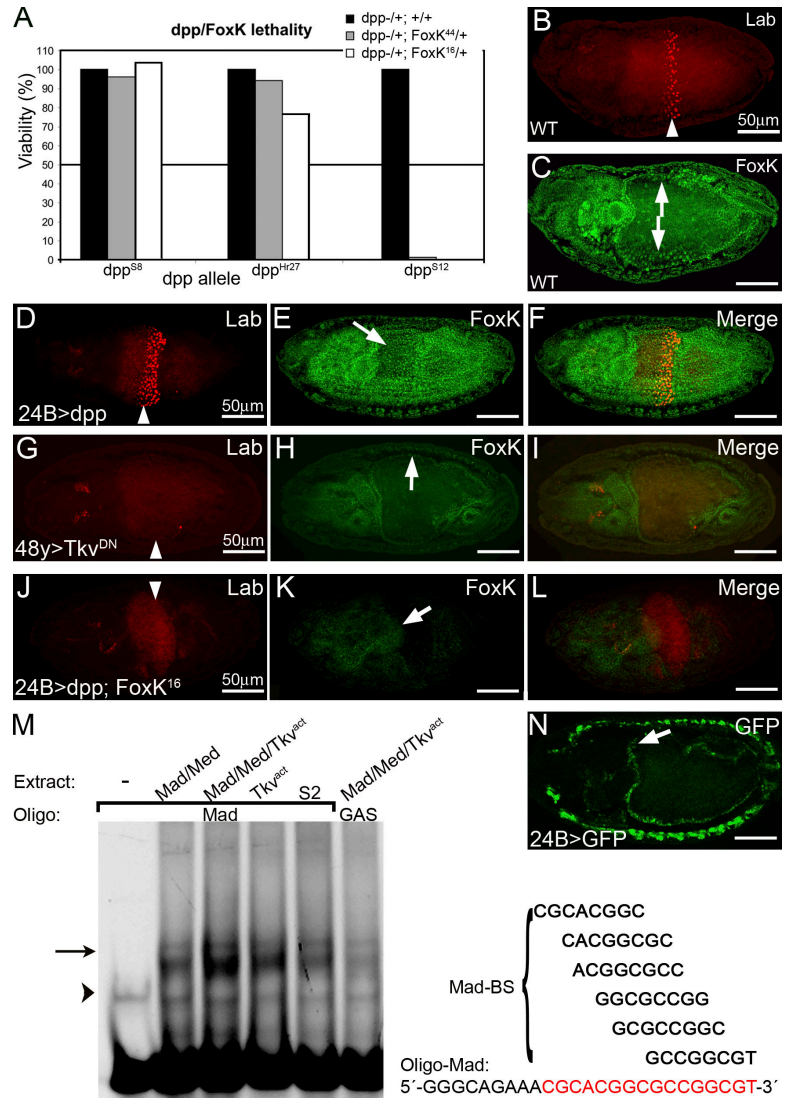

in flies overexpressing *FoxK* in the endoderm (Fig. 8, D and E, only *FoxK* loss-of-function is shown). Similarly, we found no changes in FoxK expression in embryos mutant for *Dfos* or in flies overexpressing *Dfos* in the endoderm (Fig. 8 F, only *Dfos* loss-of-function is shown). In all, these experiments ruled out mutual regulation between *FoxK* and *Dfos*. We next investigated the potential functional interaction of *FoxK* and *Dfos* by coexpressing both transcription factors in the endoderm. Remarkably, *FoxK/Dfos* coexpression induced the anterior expansion of the Lab domain (Fig. 8, compare J–L with G and H). Because *FoxK* and *Dfos* can drive ectopic *lab* expression when coexpressed, but not separately, these transcription factors may function cooperatively to regulate *lab* in the midgut endoderm.

It has been shown previously that Mad binds the regulatory region of *lab* and is required for *lab* expression (Marty et al., 2001). We wondered, though, if FoxK and Dfos could activate *lab* in the endoderm in the absence of Mad input. To inhibit Dpp signaling, we overexpressed *tkv*^{DN} in the endoderm, which prevented the accumulation of phosphorylated (activated) Mad (pSmad; Fig. 8, I and O) and Lab (Fig. 7 G) in the midgut. Next, we tested the ability of *FoxK* alone to restore Lab expression in

embryos coexpressing *tkv*^{DN}. In the absence of Dpp activity, *FoxK* was not enough to induce *lab* expression in parasegment 7 (Fig. 8, M and N). We then created embryos overexpressing *tkv*^{DN}, *FoxK*, and *Dfos* in the endoderm. Strikingly, Lab expression was restored in the midgut of these embryos, even though pSmad was undetectable in the endoderm (Fig. 8, P–R). Moreover, these embryos formed a constriction in the absence of pSmad (Fig. 8 P, arrow), which demonstrated that forced expression of *FoxK* and *Dfos* in the endoderm could bypass the Mad-dependent activation of *lab*. Thus, *lab* expression in the midgut endoderm depends on the direct activity of FoxK and Dfos, suggesting that a new, sequential signaling mechanism controls Dpp-dependent *lab* expression during endoderm development (Fig. 9).

Discussion

Drosophila FoxK displays a complex genomic organization and expression

The Fox protein family consists of at least 43 members in humans divided into 17 subfamilies (FoxA–Q; for review see Katoh, 2004). Functional studies have uncovered the role of

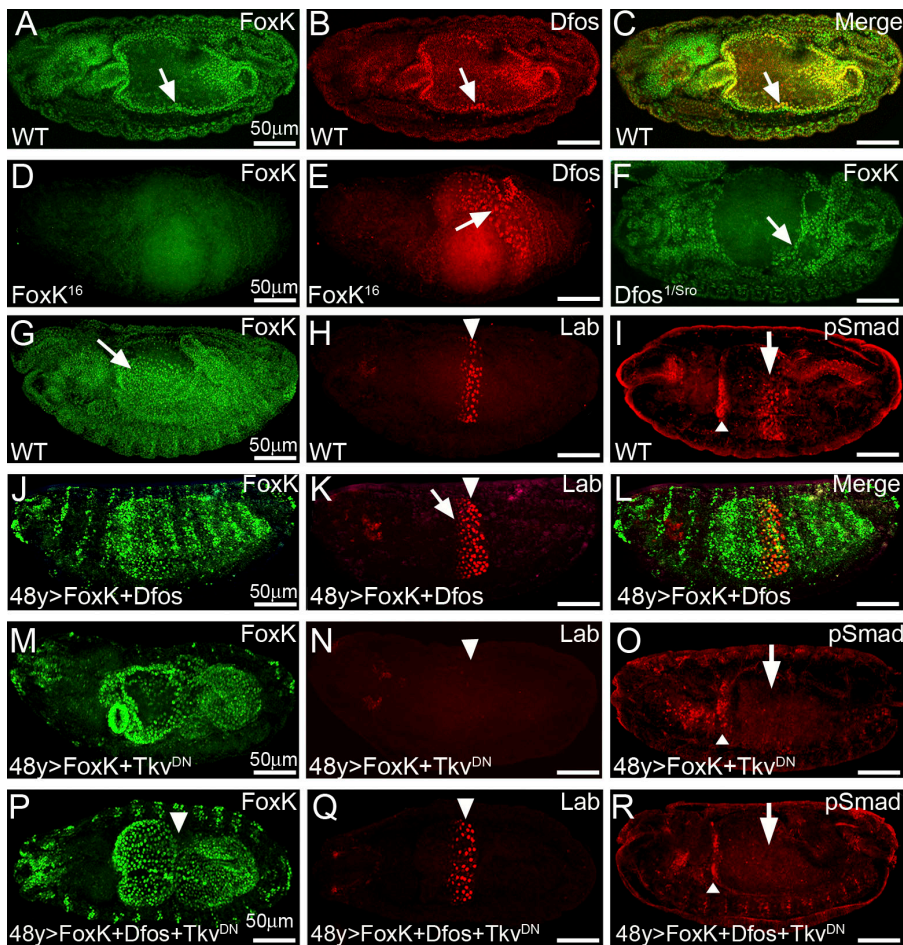

Figure 8. FoxK and Dfos regulate Lab independently of Mad. FoxK (A, arrow) and Dfos (B, arrow) colocalize in the midgut endoderm of wild-type embryos (C, arrow). Homozygous *FoxK¹⁶* embryos lack FoxK (D) but accumulate Dfos (E, arrow). (F) *Dfos^{1/Sro}* mutant embryos maintain FoxK expression in the endoderm (arrow). Wild-type expression of FoxK (G, arrow), Lab (H, arrowhead), and pSmad (I, arrow) in the midgut endoderm in stage 15 embryos. A Z-axis projection of all the endoderm is shown. The arrowhead in I indicates pSmad staining in PS3. (J–L) FoxK and Dfos coexpression in the endoderm (48Y-Gal4) induces anterior expansion of Lab (K, arrow). The arrowhead indicates the normal position of Lab. Coexpression of FoxK and *tkv^{DN}* (M, green) in the endoderm results in loss of Lab (N, arrowhead) and pSmad in PS7 (O, arrow). Coexpression of FoxK, Dfos, and *tkv^{DN}* in the endoderm restores midgut constrictions (P, arrowhead) and Lab accumulation (Q, arrowhead), whereas pSmad expression is still missing in PS7 (R, arrow). Note that the expression of pSmad in PS3 is still present (R, arrowhead).

Fox proteins in the development and differentiation of several tissues, in the control of metabolism, immunology, and lifespan, and as effectors of signal transduction cascades. Moreover, deregulation of FH genes leads to carcinogenesis and several congenital disorders in humans, including autoimmune syndromes, speech and language disorders, and diabetes (for reviews see Lehmann et al., 2003; Katoh, 2004). Thus, the Fox family of transcriptional regulators plays critical roles in development and disease that need to be understood in detail. In *Drosophila*, 17 Fox genes have been identified, but only 7 have been extensively studied (Lee and Frasch, 2004). Several *Drosophila* Fox proteins play key roles in embryonic development, including *fork head* (Weigel et al., 1989), *sloppy paired 1* and 2 (Grossniklaus et al., 1992), *crocodile* (Hacker et al., 1992), and *biniou/FoxF* (Zaffran et al., 2001; Perez Sanchez et al., 2002). In contrast, *jumeaux/FoxN* is involved in the asymmetrical division of neuronal precursors (Cheah et al., 2000), whereas FoxO is an effector of the insulin signaling pathway (Puig et al., 2003).

To increase our knowledge on Fox proteins in flies, we functionally characterized the *Drosophila* orthologue of mammalian *Foxk1*. *FoxK* produces *Long* and *Short* isoforms by the alternative splicing of exons 8 and 9, encoding proteins of 740 and 654 amino acids, respectively. However, FoxK-L and FoxK-S show similar transcriptional activity in transactivation assays, indicating that the polyglutamine-rich stretch in the C terminus is not critical for the transcriptional activity of FoxK. *FoxK-L* and *FoxK-S* also show

an interesting temporal distribution: embryonic stages only accumulate the Short isoform, adult flies only accumulate the Long isoform, whereas pupae, which contain both larval and adult tissues, produce both isoforms. The stage-specific separation of the two isoforms suggests that hormonal clues may regulate *FoxK* splicing. Interestingly, human MNF/FOXK1 also produces two isoforms by alternative splicing (MNF- α and - β), but both are expressed in muscle lineages. However, these two isoforms perform different functions during myocyte maturation and damage response. MNF- α is expressed during proliferation of undifferentiated myoblasts and shows poor ability to bind DNA, whereas MNF- β acts as a transcriptional repressor in differentiating myoblasts (Yang et al., 1997). Because the two isoforms of *Drosophila* FoxK only cohabitate in pupae, FoxK-L and FoxK-S could exert the same regulatory activity in different stages.

FoxK is essential for midgut endoderm development

FoxK exhibits a broad distribution in embryos, including the central nervous system, the midgut endoderm, and the epidermis; however, no obvious phenotypes seem to be associated to this widespread expression. We determined, though, that early *FoxK* activity provided maternally is critical for embryonic development. Thus, maternal *FoxK* may be involved in early segmentation events and may rescue early *FoxK* zygotic requirements, although we did not study these phenotypes in detail.

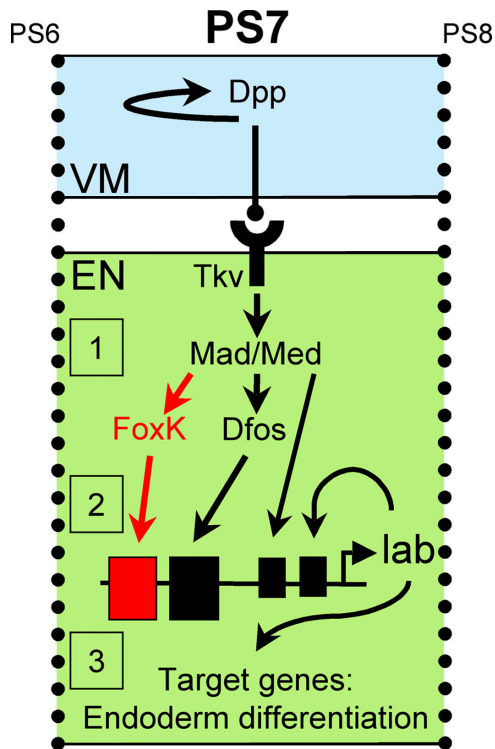

Figure 9. **Dpp signaling events in the endoderm.** Diffusion of Dpp from the visceral mesoderm (VM) activates its receptor, Tkv, in the underlying endoderm (EN), which leads to the formation of transcriptionally active Mad–Med complexes (1). Mad and Med then regulate the expression of FoxK and Dfos, which are critical for the initiation of *lab* expression by binding to its promoter (2, large boxes). Mad may contribute to *lab* activation, whereas Mad and Lab are necessary for *lab* maintenance. Finally, Lab controls the expression of target genes critical for copper cell differentiation (3).

Based on the strong midgut phenotypes detected in *FoxK* mutant embryos, we focused on understanding the zygotic activity of *FoxK* in endoderm development. Embryos lacking *FoxK* exhibit arrested midgut development at stages 15–16, in which the constrictions do not form. These *FoxK* mutant embryos specifically remove Lab expression in the endoderm, whereas the expression of Tsh, a transcription factor key for the specification of other intestinal lineages, is not affected. Moreover, the lack of other constrictions outside of the Lab domain clearly indicates that *FoxK* has other activities during midgut development. We have also identified several optimal FoxK-binding sites in the regulatory region of *lab* and proved the functionality of a 678-bp element containing five FH-binding sites. Our results, thus, support a direct transcriptional regulation of *lab* by FoxK in parasegment 7, indicating that *FoxK* plays a key role in midgut development.

FoxK is a novel Dpp target and effector in the endoderm

Several groups in the early 1990's contributed to the discovery that the signaling activity of Dpp in the visceral mesoderm controls *lab* expression in the endoderm (for reviews see Bienz, 1997; Nakagoshi, 2005). Similarly to *Dfos*, expression of *FoxK* in the midgut endoderm depends directly on Dpp signaling, and both seem to be key components of the Dpp signaling cascade required for *lab* induction in the endoderm. However, we were

puzzled by the inability of FoxK and Dfos to direct *lab* expression by themselves (Szuts and Bienz, 2000). Because both *FoxK* and *Dfos* encode for transcription factors, we hypothesized and demonstrated that they could work coordinately to control *lab* expression.

But, how do FoxK and Dfos fit in the classical model in which Mad directly activates *lab*? It has been proposed that Mad binds tissue- or cell-specific transcription factors that provide specificity to the multiple tissues that use the Dpp signaling pathway during specification or differentiation (Affolter et al., 2001). Following this hypothesis, the transcription factors FoxK and Dfos could be the endoderm partners of Mad that provide the tissue-specific clues necessary for *lab* expression in parasegment 7 of the endoderm. However, we have shown that FoxK and Dfos can restore *lab* expression in the endoderm in the absence of pSmad (Fig. 8 Q), suggesting that activated Mad is not necessary for *lab* expression. In fact, the *lab550* minimal regulatory element contains a weak Dpp response element that includes activator as well as repressor domains (Marty et al., 2001). Moreover, *lab550* activation strongly depends on Lab self-regulation, suggesting that *lab550* is most likely involved in *lab* maintenance rather than in its initiation. Hence, factors other than Mad and Lab must be critical for stimulating *lab* transcription, whereas Mad input and Lab autoregulation may be key for subsequent *lab* maintenance.

Our data, thus, support a new model for Dpp-dependent endoderm specification that involves the sequential activation of transcription factors that progressively restrict the developmental potential of the target tissue (Fig. 9). In our model, Dpp first activates Mad as a general/primary effector of Dpp signaling in the endoderm and other tissues (Fig. 9). Activated Mad then directly regulates the expression of *FoxK* and *Dfos*, the tissue-specific/secondary effectors of Dpp signaling in the endoderm. FoxK and Dfos, in turn, induce the expression of *lab*, the differentiation/tertiary Dpp effector in parasegment 7 of the endoderm. Finally, Lab controls the expression of target genes critical for the functional differentiation of copper cells in the midgut, some of which may have already been described (Leemans et al., 2001). It is still possible, though, that small amounts of pMad are present in our Tkv^{DN} experiments that are undetectable using the anti-pSmad antibody. In this scenario, we would have to consider a more classical model where a functional complex containing Mad, FoxK, and Dfos is necessary for the specification of endoderm and activation of *lab*. However, we still favor the sequential model because a reduction in activated Mad should result, contrary to what we find, in some degree of Lab loss. But, because we did not test in Mad-null conditions, we cannot rule out the direct role of Mad in activating *lab* expression.

Conserved mechanisms of endoderm development

Transcriptional regulators of the GATA and Fox families are conserved molecular mediators of endoderm specification in vertebrates and invertebrates (Fukuda and Kikuchi, 2005; for review see Nakagoshi, 2005). In both *Drosophila* and mice, Fkh/FoxA1/FoxA2 and Serpent/GATA proteins function in the early stages of

specification of endodermal precursors. In mice, *Foxa1* is necessary for pancreas and β cell differentiation and *Foxa2* is critical for development of the mature endoderm, whereas forced expression of *Foxa1* induces stem cells to differentiate into endoderm (Tam et al., 2003). Moreover, intercellular signaling between cell layers by signaling molecules of the TGF- β /Dpp and the Wnt/Wg families is also critical for endoderm differentiation in both vertebrates and invertebrates. We have characterized a new role for FoxK in endoderm development in flies. Interestingly, the mouse Foxk1/MNF- α isoform is also abundant in brain, kidney, spleen, and liver (Bassel-Duby et al., 1994; Yang et al., 1997). The vertebrate liver is a derivative of the endoderm, suggesting that mammalian FOXK1 is also involved in endoderm development. However, because the expression pattern of Foxk1 in mice is unknown at this time, we can only speculate about its potential role in other endoderm derivatives, such as the lining of the gut and the pancreas.

Materials and methods

RT-PCR and FoxK transcripts

RT-PCR was performed with total RNA using the Ultraspec-II RNA system (Biotecx). The amplified fragments were sequenced using a sequencer (ABI-377; Applied Biosystems). Sequences were submitted to GeneBank/EMBL/DDBJ under accession numbers AY787837 (*FoxK-S*) and AY787838 (*FoxK-L*). For alignments, we used *Mus musculus Foxk1* (NM_010812) and *Homo sapiens Foxk1* (X60787). The following primers were used (position refers to FoxK ATG): FoxK1, 5'-CCTTCAATGGCCGCCAC-TACC-3'; FoxK800, 5'-CTGCTACTTCCGCTCCCGAGC-3'; FoxK1242, 5'-ACGGATCCCATTGAGCAATCAGCCCAAT-3'; FoxK1650, 5'-CAGGAC-GAGCCCGAAAGGGT-3'; FoxK1950, 5'-CTGTACTGATTGGAATG-TTTG-3'; FoxK69c, 5'-GTTGTGGAGCTGCTATTGC-3'; FoxK1200c, 5'-GCCAGTTGGTGATAGGTAGG-3'; FoxK1450c, 5'-GGAACCCITTC-GGGCTCGTCC-3'; FoxK1800c, 5'-CTGTACTGATTGGAATTGTTG-3'; FoxK2220c, 5'-TCAGAGCACTCCGACACATAC-3'; FoxK.5'A, 5'-GAA-GCAATAAGAATCGGGAAAACC-3'; FoxK.5'D, 5'-CACGCTCATCAA-CACACATGC-3'; FoxK.5'B, 5'-CATAGTTGCCATTTGTTGCACAG-3'; FoxK.5'C, 5'-CAATCAGTGGCGGAATAAAAC-3'.

Cell culture and transactivation assays

FoxK-S and *FoxK-L* cDNAs were obtained by RT-PCR and cloned into pAc5.1/V5-His (Invitrogen) in frame with the V5 epitope, yielding the expression constructs pAc5C>*FoxK-S* and pAc5C>*FoxK-L*. Six copies of a double-stranded Oligo-FH (see Recombinant GST-FoxK fusion protein and DNA-binding assays) containing a consensus FH-binding site were cloned in a pGL3 basic-derived reporter plasmid (Promega) driving luciferase expression (6xFH>Luc). The pAc5.1/V5-His/LacZ vector was used to normalize the transactivation assays. Also, the 678-*lab* regulatory region was obtained by PCR and cloned into the pGL3-luc vector. 1.5×10^6 S2 cells were transfected with SuperFect (QIAGEN) using 1 μ g DNA from each construct. Cells were treated with passive lysis buffer to determine luciferase activity [Single Luciferase Assay kit; Promega]. For immunostaining, transfected cells were fixed and incubated with anti-V5 antibody (1:5,000; Invitrogen) and FITC-coupled anti-mouse antibody (1:100; Jackson ImmunoResearch Laboratories). To generate cellular extracts for EMSA, *Mad*, *Med*, and *tkv^{cd}* (gifts from B. Hartmann, University of Basel, Basel, Switzerland) were cloned in pAc5.1B/V5-His (Invitrogen) and S2 cells were transfected. Protein extracts enriched in activated *Mad* and *Med* were used in EMSA.

Western blot and dephosphorylation assays

For Western blot, S2 cells were cotransfected with pAc5.1/V5-His/LacZ and pAc5C>*FoxK-S-V5* or pAc5C>*FoxK-L-V5* plasmids, and protein extracts were separated by SDS-PAGE 4–12% gels (Invitrogen) under reducing conditions, electroblotted into nitrocellulose membranes, and probed against V5 (1:10,000; Invitrogen) and β -galactosidase (1:20,000; Sigma-Aldrich) antibodies. For dephosphorylation assays, protein extracts from cells expressing FoxK-S and FoxK-L were treated with 1–10 U of shrimp (Promega) or calf (Roche) alkaline phosphatases or protein phosphatase 1 (EMD) according to the manufacturer's instructions.

Recombinant GST-FoxK fusion protein and DNA-binding assays

A 720-bp fragment of the *FoxK-S* cDNA, encoding residues 414–654 (including the FH domain), was cloned in pGEX-3X (GE Healthcare) in frame with GST (GST-FoxK[414–654]). The recombinant protein was purified by affinity chromatography in glutathione-sepharose columns for EMSA (Perez-Sanchez et al., 2000). For radioactive EMSA, crude cell extracts or purified recombinant GST-FoxK fusion proteins were incubated with radioactive oligonucleotide probes. Double-stranded oligonucleotide probes were labeled with α -[³²P]dCTP by Klenow and 1 ng of probe was used per assay. 1 μ g of poly(dI-dC)-poly(dI-dC) was added as a nonspecific competitor. The following ³²P-labeled oligonucleotides were used: oligo FH, 5'-GGTCAAACGTAACAATCCAG-3' (FH-binding site underlined); Sub, 5'-GGAGGGAGCTTAGGTAACAGTGCTGCTT (suboptimal FH-binding site underlined and changes in bold); GAS, 5'-GCGTCTTTCCGGGAAATA-CAT-3' (γ -interferon-activating site); oligo FH2, 5'-GGGGTACATACATA-AATACAGCGG-3' (genomic sequence 676-bp upstream of *FoxK*; FH-binding site underlined).

For nonradioactive EMSA, cell extracts were incubated with cold double-stranded DNA probes and separated in 6% polyacrylamide gels (no SDS). The gel was stained with SYBR (Invitrogen) for DNA detection. Oligo-Mad, 5'-GGGCAGAAACGCACGGCCCGGCGT-3', genomic sequence 5' of *FoxK* underlined and contains six overlapping Mad-binding sites (Fig. 7 M).

Generation of anti-FoxK antibody

The purified recombinant GST-FoxK[414–654] fusion protein was used to immunize three mice in subcutaneous injections. Polyclonal serum anti-GST-FoxK protein was purified in agarose affinity columns (Bio-Rad Laboratories). Pre-bleed serum did not produce signal.

In situ hybridizations, immunohistochemistry, and image acquisition

Digoxigenin-labeled sense and antisense riboprobes from *FoxK* (encompassing nucleotides 1,533–1,886 of the *FoxK-S* isoform) were used for in situ hybridization following standard procedures. For immunostaining, fly embryos were incubated with mouse anti-FoxK (1:100), rabbit anti-Lab (1:100; a gift from T. Kaufman, Indiana University, Bloomington, IN), rat anti-Elav (1:50; Developmental Studies Hybridoma Bank), rabbit anti-Dfos (1:100; gifts from D. Bohmann, Rochester University, Rochester, NY, and S.X. Hou, National Cancer Institute, Bethesda, MD), and pSmad (1:100; a gift from P. ten Dijke, Leiden University Medical Center, Leiden, Netherlands) primary antibodies. As secondary antibodies, we used Cy3- (Invitrogen), or FITC-conjugated antibodies (1:600) and embryos were mounted on Vectashield (Vector Laboratories). Light microscopy was performed at 25°C on a microscope with Nomarski optics equipped with a Nikon DXm 1200 camera. Confocal images were performed on a Zeiss LSM510 confocal microscope (ES300; Nikon) using Plan-Apo CS 20 \times NA 0.7 and 63 \times NA 1.4 objectives (Carl Zeiss, Inc.). The acquisition software was LSM510-META workstation 4.0 and projections of the confocal images were done with Metamorph V7.0 (MDS Analytical Technologies). Panels were assembled in figures using Photoshop (Adobe). Brightness and/or contrast were optimized for whole panels without enhancing specific parts of the panels. The stages of embryonic development cited are those according to Campos-Ortega and Hartenstein (1997).

Fly strains, generation of excision lines, and transgenic flies

The *FoxK-S* cDNA was cloned into pUAST (Brand and Perrimon, 1993) and injected in *yw* embryos. Imprecise *P* element mobilization of the insertion EP(3)3428 (Szeged Drosophila Stock Center) was performed using *Sb P-ry¹²³e/TM6*. *FoxK* mutations were balanced over *TM3*, *Act>GFP* to identify homozygous mutant embryos. The *Tp(3;Y)B233, y[+]/TM6* strain contains a duplication of 67E-70A region (including *FoxK*) on the Y chromosome. *UAS-Dfos*, *UAS-GFP (nls)*, *Dfos/Kay¹*, *Dfos/Kay⁵⁰*, *48Y-Gal4* (endoderm), *24B-Gal4* (mesoderm), and *tub-Gal4-VP16* (maternally loaded into eggs) were obtained from the Bloomington Drosophila Stock Center. The *FoxKi* strain was obtained from the Vienna Drosophila RNAi Collection. The *dpp* alleles, *dpp⁸⁸*, *dpp¹²*, and *dpp^{H727}*, were obtained from I. Guerrero (Centro de Biología Molecular Severo Ochoa, Consejo Superior de Investigaciones Científicas, Madrid, Spain). *UAS-dpp* was a gift from G. Marques (University of Birmingham, Birmingham, AL) and *UAS-tkv^{DN}* was obtained from M. O'Connor (University of Minnesota, Minneapolis, MN). The wild-type flies used were *Oregon-R*. All strains were maintained and crossed at 25°C.

Online supplemental material

Fig. S1 shows that Lab expression rescues constriction formation in FoxK mutant embryos. Online supplemental material is available at <http://www.jcb.org/cgi/content/full/jcb.200808149/DC1>.

We are grateful to Lucas Sanchez and Nandy Ruiz for helpful discussions; Diego Rincon-Limas and Grace Boekhoff-Falk for critical reading of the manuscript; Lola Mateos, the Centro de Investigaciones Biológicas sequencing center, and Leoncio Vergara for technical assistance; and Isabel Guerrero, Guillermo Marques, Michael O'Connor, Thomas Kaufman, Britta Hartmann, Steven Hou, Dirk Bohmann, Peter ten Dijke, the Developmental Studies Hybridoma Bank, the Bloomington *Drosophila* Stock Center, the Vienna *Drosophila* RNAi Collection, and the Szeged *Drosophila* Stock Center for critical reagents.

This work was supported by the Spanish Ministerio de Ciencia y Tecnología (project BMC2002-04646). S. Casas-Tinto received a PhD fellowship from the Spanish Ministerio de Ciencia y Tecnología.

Submitted: 28 August 2008

Accepted: 13 November 2008

References

- Affolter, M., T. Marty, M.A. Vigano, and A. Jazwinska. 2001. Nuclear interpretation of Dpp signaling in *Drosophila*. *EMBO J.* 20:3298–3305.
- Bassel-Duby, R., M.D. Hernandez, Q. Yang, J.M. Rochelle, M.F. Seldin, and R.S. Williams. 1994. Myocyte nuclear factor, a novel winged-helix transcription factor under both developmental and neural regulation in striated myocytes. *Mol. Cell. Biol.* 14:4596–4605.
- Bienz, M. 1997. Endoderm induction in *Drosophila*: the nuclear targets of the inducing signals. *Curr. Opin. Genet. Dev.* 7:683–688.
- Brand, A.H., and N. Perrimon. 1993. Targeted gene expression as a means of altering cell fates and generating dominant phenotypes. *Development.* 118:401–415.
- Campos-Ortega, J.A., and V. Hartenstein. 1997. The Embryonic Development of *Drosophila melanogaster*. Second edition. Springer, Berlin. 227 pp.
- Cheah, P.Y., W. Chia, and X. Yang. 2000. Jumeaux, a novel *Drosophila* winged-helix family protein, is required for generating asymmetric sibling neuronal cell fates. *Development.* 127:3325–3335.
- Durocher, D., and S.P. Jackson. 2002. The FHA domain. *FEBS Lett.* 513:58–66.
- Fukuda, K., and Y. Kikuchi. 2005. Endoderm development in vertebrates: fate mapping, induction and regional specification. *Dev. Growth Differ.* 47:343–355.
- Granadino, B., C. Arias-de-la-Fuente, C. Perez-Sanchez, M. Parraga, L.A. Lopez-Fernandez, J. del Mazo, and J. Rey-Campos. 2000. Fhx (Foxj2) expression is activated during spermatogenesis and very early in embryonic development. *Mech. Dev.* 97:157–160.
- Grossniklaus, U., R.K. Pearson, and W.J. Gehring. 1992. The *Drosophila* sloppy paired locus encodes two proteins involved in segmentation that show homology to mammalian transcription factors. *Genes Dev.* 6:1030–1051.
- Hacker, U., U. Grossniklaus, W.J. Gehring, and H. Jackle. 1992. Developmentally regulated *Drosophila* gene family encoding the fork head domain. *Proc. Natl. Acad. Sci. USA.* 89:8754–8758.
- Immergluck, K., P.A. Lawrence, and M. Bienz. 1990. Induction across germ layers in *Drosophila* mediated by a genetic cascade. *Cell.* 62:261–268.
- Katoh, M. 2004. Human FOX gene family (Review). *Int. J. Oncol.* 25:1495–1500.
- Kusanagi, K., H. Inoue, Y. Ishidou, H.K. Mishima, M. Kawabata, and K. Miyazono. 2000. Characterization of a bone morphogenetic protein-responsive Smad-binding element. *Mol. Biol. Cell.* 11:555–565.
- Lee, H.H., and M. Frasch. 2004. Survey of forkhead domain encoding genes in the *Drosophila* genome: classification and embryonic expression patterns. *Dev. Dyn.* 229:357–366.
- Leemans, R., T. Loop, B. Egger, H. He, L. Kammermeier, B. Hartmann, U. Certa, H. Reichert, and F. Hirth. 2001. Identification of candidate downstream genes for the homeodomain transcription factor Labial in *Drosophila* through oligonucleotide-array transcript imaging. *Genome Biol.* 2:5.
- Lehmann, O.J., J.C. Sowden, P. Carlsson, T. Jordan, and S.S. Bhattacharya. 2003. Fox's in development and disease. *Trends Genet.* 19:339–344.
- Li, C., C.F. Lai, D.S. Sigman, and R.B. Gaynor. 1991. Cloning of a cellular factor, interleukin binding factor, that binds to NFAT-like motifs in the human immunodeficiency virus long terminal repeat. *Proc. Natl. Acad. Sci. USA.* 88:7739–7743.
- Marty, T., M.A. Vigano, C. Ribeiro, U. Nussbaumer, N.C. Grieder, and M. Affolter. 2001. A HOX complex, a repressor element and a 50 bp sequence confer regional specificity to a DPP-responsive enhancer. *Development.* 128:2833–2845.
- Massague, J., and D. Wotton. 2000. Transcriptional control by the TGF-beta/Smad signaling system. *EMBO J.* 19:1745–1754.
- Mathies, L.D., S. Kerridge, and M.P. Scott. 1994. Role of the teashirt gene in *Drosophila* midgut morphogenesis: secreted proteins mediate the action of homeotic genes. *Development.* 120:2799–2809.
- Miller, D.F., B.T. Rogers, A. Kalkbrenner, B. Hamilton, S.L. Holtzman, and T. Kaufman. 2001. Cross-regulation of Hox genes in the *Drosophila melanogaster* embryo. *Mech. Dev.* 102:3–16.
- Nakagoshi, H. 2005. Functional specification in the *Drosophila* endoderm. *Dev. Growth Differ.* 47:383–392.
- Nakagoshi, H., M. Hoshi, Y. Nabeshima, and F. Matsuzaki. 1998. A novel homeobox gene mediates the Dpp signal to establish functional specificity within target cells. *Genes Dev.* 12:2724–2734.
- Panganiban, G.E., R. Reuter, M.P. Scott, and F.M. Hoffmann. 1990. A *Drosophila* growth factor homolog, decapentaplegic, regulates homeotic gene expression within and across germ layers during midgut morphogenesis. *Development.* 110:1041–1050.
- Perez-Sanchez, C., M.A. Gomez-Ferrera, C.A. de La Fuente, B. Granadino, G. Velasco, A. Esteban-Gamboa, and J. Rey-Campos. 2000. FHX, a novel fork head factor with a dual DNA binding specificity. *J. Biol. Chem.* 275:12909–12916.
- Perez Sanchez, C., S. Casas-Tinto, L. Sanchez, J. Rey-Campos, and B. Granadino. 2002. DmFoxF, a novel *Drosophila* fork head factor expressed in visceral mesoderm. *Mech. Dev.* 111:163–166.
- Puig, O., M.T. Marr, M.L. Ruhf, and R. Tjian. 2003. Control of cell number by *Drosophila* FOXO: downstream and feedback regulation of the insulin receptor pathway. *Genes Dev.* 17:2006–2020.
- Reuter, R., and M.P. Scott. 1990. Expression and function of the homeotic genes Antennapedia and Sex combs reduced in the embryonic midgut of *Drosophila*. *Development.* 109:289–303.
- Reuter, R., G.E. Panganiban, F.M. Hoffmann, and M.P. Scott. 1990. Homeotic genes regulate the spatial expression of putative growth factors in the visceral mesoderm of *Drosophila* embryos. *Development.* 110:1031–1040.
- Riese, J., G. Tremml, and M. Bienz. 1997. D-Fos, a target gene of Decapentaplegic signalling with a critical role during *Drosophila* endoderm induction. *Development.* 124:3353–3361.
- Staebling-Hampton, K., and F.M. Hoffmann. 1994. Ectopic decapentaplegic in the *Drosophila* midgut alters the expression of five homeotic genes, dpp, and wingless, causing specific morphological defects. *Dev. Biol.* 164:502–512.
- Szuts, D., and M. Bienz. 2000. An autoregulatory function of Dfos during *Drosophila* endoderm induction. *Mech. Dev.* 98:71–76.
- Tam, P.P., M. Kanai-Azuma, and Y. Kanai. 2003. Early endoderm development in vertebrates: lineage differentiation and morphogenetic function. *Curr. Opin. Genet. Dev.* 13:393–400.
- Weigel, D., and H. Jackle. 1990. The fork head domain: a novel DNA binding motif of eukaryotic transcription factors? *Cell.* 63:455–456.
- Weigel, D., G. Jurgens, F. Kuttner, E. Seifert, and H. Jackle. 1989. The homeotic gene fork head encodes a nuclear protein and is expressed in the terminal regions of the *Drosophila* embryo. *Cell.* 57:645–658.
- Yang, Q., R. Bassel-Duby, and R.S. Williams. 1997. Transient expression of a winged-helix protein, MNF-beta, during myogenesis. *Mol. Cell. Biol.* 17:5236–5243.
- Zaffran, S., A. Kuchler, H.H. Lee, and M. Frasch. 2001. binou (FoxF), a central component in a regulatory network controlling visceral mesoderm development and midgut morphogenesis in *Drosophila*. *Genes Dev.* 15:2900–2915.