

# Acetate Transport in the S3 Segment of the Rabbit Proximal Tubule and its Effect on Intracellular pH

NAZIH L. NAKHOUL and WALTER F. BORON

From the Department of Cellular and Molecular Physiology, Yale University School of Medicine, New Haven, Connecticut 06510

**ABSTRACT** We monitored intracellular pH ( $pH_i$ ) in isolated perfused S3 segments of the rabbit proximal tubule, and studied the effect of acetate ( $Ac^-$ ) transport on  $pH_i$ .  $pH_i$  was calculated from the absorbance spectrum of 4',5'-dimethyl-5-(and 6) carboxyfluorescein trapped intracellularly. All solutions were nominally  $HCO_3^-$ -free. Removal of 10 mM  $Ac^-$  from bath and lumen caused  $pH_i$  to rapidly rise by  $\sim 0.2$ , and then to decline more slowly to a value  $\sim 0.35$  below the initial one. Removal of only luminal  $Ac^-$  caused  $pH_i$  changes very similar to those resulting from bilateral removal of  $Ac^-$ . When  $Ac^-$  was removed from bath only,  $pH_i$  rose rapidly at first, and then continued to rise more slowly. Readdition of  $Ac^-$  to bath caused  $pH_i$  to rapidly fall to a value slightly higher than the one prevailing before the removal of  $Ac^-$  from the bath. In experiments in which  $Ac^-$  was first removed from both bath and lumen, readdition of 10 mM  $Ac^-$  to only lumen caused a rapid but small acidification, followed by a slower alkalization that brought the  $pH_i$  near the value that prevailed before the bilateral removal of  $Ac^-$ . The alkalizing effects caused by the readdition of 10 or 0.5 mM  $Ac^-$  were indistinguishable. When  $Ac^-$  was returned to only lumen in the absence of luminal  $Na^+$ , there was a small and rapid  $pH_i$  decrease, but no  $pH_i$  recovery. Removal of  $Na^+$  from bath did not affect the  $pH_i$  transients caused by the addition of  $Ac^-$  to lumen. In experiments in which  $Ac^-$  was first removed bilaterally, readdition of  $Ac^-$  to only bath caused a large and sustained drop in  $pH_i$ , whereas the subsequent removal of  $Ac^-$  from the bath caused a slight alkalization. These  $pH_i$  changes caused by readdition or removal of  $Ac^-$  from baths were unaffected by the absence of external  $Na^+$ . We conclude that there is a  $Na^+/Ac^-$  cotransporter at the luminal membrane, and pathways for acetic acid transport at both luminal and basolateral membranes. The net effect of  $Ac^-$  transport on  $pH_i$  is to alkalize the cell as a result of the luminal entry of  $Na^+/Ac^-$ , which is followed by the luminal and basolateral exit of acetic acid.

## INTRODUCTION

Nearly 70% of the reabsorptive work of the kidney involves the transport of solutes by the proximal tubule. Monocarboxylic acids and other metabolic substrates that

Address reprint requests to Dr. Walter F. Boron, Department of Cellular and Molecular Physiology, Yale University School of Medicine, 333 Cedar Street, P.O. Box 3333, New Haven, CT 06510-8026.

are taken up from the lumen by cells of the proximal tubule can be handled in one of three ways. First, some of these organic solutes may be metabolized in the proximal-tubule cell to produce energy. It is known that proximal-tubule cells metabolize lactate, pyruvate, and a variety of Krebs's cycle intermediates (Mandel, 1985). Moreover, work on whole kidneys has established that both acetate ( $\text{Ac}^-$ ) (Mudge, 1951) and acetoacetate (Guder et al., 1986) are excellent fuels. The second possible fate of some of these organic solutes is the conversion from one substrate to another; for example, from lactate to glucose (Gullans et al., 1984). Finally, some of the organic solutes taken up from the lumen can be transferred to the basolateral solution. Evidence for transcellular reabsorption comes from whole kidney experiments in which it has been found that the oxidation of organic substrates such as lactate is a small fraction of the amount reabsorbed (Cohen and Barac-Nieto, 1973). In the isolated tubule preparation of the rabbit S2 segment (Schafer and Andreoli, 1976), evidence was provided for an energy-dependent process responsible for the reabsorption of  $\text{Ac}^-$  from the lumen.

In spite of its potential importance, relatively little is known about monocarboxylic-acid transport in intact proximal tubules or proximal-tubule cells. Major difficulties are the metabolism of these substrates and the lack of nonmetabolized analogues (see Wright, 1985). For these reasons, much of what is known is derived from studies using vesicle preparations. Four distinct mechanisms for the transport of monocarboxylates have been demonstrated or proposed. The first is a  $\text{Na}^+$ -coupled monocarboxylate cotransporter. For example, evidence for luminal  $\text{Na}^+$ /lactate cotransport in the proximal tubule is derived from studies on brush border vesicles of rat (Barac-Nieto et al., 1980), rabbit (Nord et al., 1983), and horse (Mengual and Sudaka, 1983). In a study on intact tubules, Siebens and Boron (1987) have reported evidence for luminal  $\text{Na}^+$ /lactate cotransport in the isolated proximal tubule of the salamander. A second proximal-tubule monocarboxylate transport mechanism, identified in membrane-vesicle studies, exchanges  $\text{Cl}^-$  for either urate (Kahn and Aronson, 1983) or formate (Schild et al., 1986). Formate and urate are not substrates for the  $\text{Na}^+$ -coupled monocarboxylate system, nor are the other monocarboxylates substrates for the  $\text{Cl}^-$  exchange system. A third example of monocarboxylate transport is  $\text{H}^+$ /monocarboxylate cotransport (or monocarboxylate/base exchange).  $\text{H}^+$ /lactate cotransport has been reported in Ehrlich ascites tumor cells (Spencer and Lehninger, 1976), cardiac Purkinje fibers (DeHemptinne et al., 1983), and the basolateral membrane of the salamander proximal tubule (Siebens and Boron, 1987). Finally, one might expect the neutral, protonated form of weak monocarboxylic acids to move across plasma membranes by simple nonionic diffusion.

The studies summarized above indicate that there is limited information at the cellular level concerning monocarboxylate transport. In particular for epithelial cells, it is crucial to understand how the transport of monocarboxylates at the luminal membrane interacts with the transport at the basolateral membrane. Inasmuch as monocarboxylates are weak bases, one might expect their transport to affect and to be affected by pH. However, although  $\text{pH}_i$  as well as extracellular pH affect the net efflux of lactate from the rat proximal-tubule lumen (Ullrich et al., 1982), it is not yet known how the transport of monocarboxylic acids might affect  $\text{pH}_i$  in mammalian tubules.

In the preceding paper (Nakhoul et al., 1988) we found, in the isolated perfused S3 segment of the rabbit proximal tubule, that a major component of the  $\text{pH}_i$  recovery from intracellular acid loads requires both luminal  $\text{Na}^+$  and luminal  $\text{Ac}^-$ . The latter is a common component of mammalian Ringer's solutions. In the present study, we have investigated the ionic mechanism of this  $\text{Na}^+$ - and  $\text{Ac}^-$ -dependent acid-extrusion process by studying the effect of  $\text{Ac}^-$  transport on  $\text{pH}_i$ . To minimize the effects of  $\text{HCO}_3^-$  transport, experiments were performed in nominally  $\text{HCO}_3^-$ -free solutions.  $\text{pH}_i$  was calculated from the absorbance spectrum of a pH-sensitive dye incorporated into the proximal-tubule cells. We found that: (a) there is a potent  $\text{Na}^+/\text{Ac}^-$  cotransport system at the luminal membrane; (b) acetic acid (HAc) is transported across both the luminal and basolateral membranes, either by nonionic diffusion of HAc, a  $\text{H}^+/\text{Ac}^-$  cotransporter, or by an  $\text{Ac}^-/\text{base}$  exchanger; and that (c) the combined effect of the  $\text{Na}^+/\text{Ac}^-$  and HAc transport systems is a net extrusion of acid from the cell, and the likely net reabsorption of  $\text{Ac}^-$ . The former leads to a substantial increase in steady-state  $\text{pH}_i$ . Thus, at least in the nominal absence of  $\text{HCO}_3^-$ , these  $\text{Ac}^-$  transport systems have a major effect on  $\text{pH}_i$  regulation.

#### METHODS

The details of the methodology are contained in the preceding paper (Nakhoul et al., 1988). The experiments were performed on isolated perfused S3 segments of the rabbit proximal tubule. Tubule cells were loaded with the pH-sensitive dye 4',5'-dimethyl-5-(and 6) carboxy-fluorescein. The absorbance spectrum of this dye was determined by illuminating a tubule with a 10- $\mu\text{m}$  diam spot of white light, and focusing the transmitted light on a 1024-element photodiode array.  $\text{pH}_i$  was calculated from the absorbance spectrum, employing a calibration obtained with nigericin/high- $\text{K}^+$  solutions (see Thomas et al., 1979). The compositions of the basolateral (i.e., bath) and luminal solutions are given in Table I. All experiments were performed in the nominal absence of  $\text{HCO}_3^-$  to minimize the contribution of  $\text{HCO}_3^-$ -dependent acid/base transporters to the measurement of  $\text{pH}_i$ . The temperature in the chamber was maintained at 38°C.

#### *Statistics and Data Analysis*

Means are reported  $\pm$  SE. Statistical significance was judged from paired and unpaired Student's *t* test, as indicated in the text. Rates of  $\text{pH}_i$  change were determined by using a computer to fit the  $\text{pH}_i$  vs. time data to a straight line.

#### RESULTS

##### *Bilateral Removal of $\text{Ac}^-$ and Phosphate*

We first examined the effect on  $\text{pH}_i$  of removing  $\text{Ac}^-$  and inorganic phosphate (Pi), the only two buffers (other than HEPES) normally present in our standard  $\text{HCO}_3^-$ -free solution. As shown in Fig. 1, bilaterally exposing the tubule to solutions lacking both  $\text{Ac}^-$  and Pi (solution 2, Table I) results in a transient rise in  $\text{pH}_i$  (*ab*) followed by a slower decline to a value far below the initial one (*bc*). In a series of similar experiments, the average transient rise of  $\text{pH}_i$  was  $0.19 \pm 0.01$  ( $n = 32$ ), whereas the average decline below the initial value (comparing points *a* and *c*) was  $0.35 \pm 0.03$  ( $n = 17$ ). When  $\text{Ac}^-$  and Pi are returned to the luminal and basolateral solutions, the  $\text{pH}_i$  transients are similar but opposite in direction to those elicited by removal of

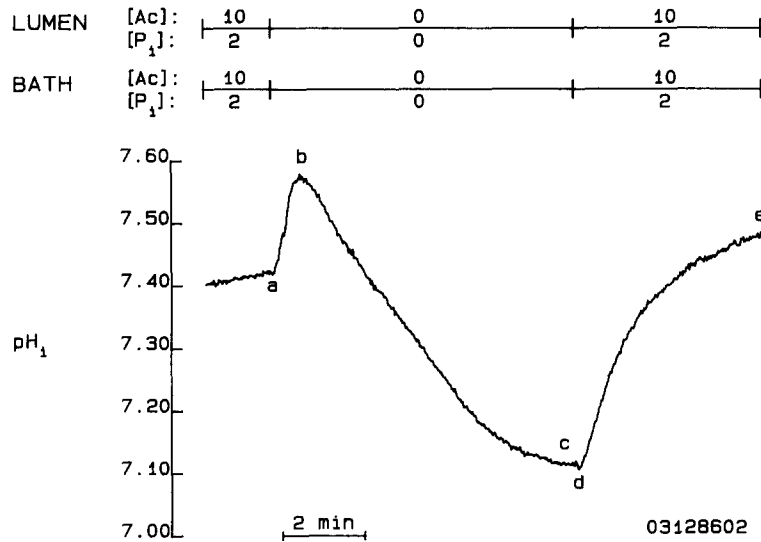

FIGURE 1. Effect on  $\text{pH}_i$  of bilateral removal and readdition of external  $\text{Ac}^-$  and phosphate. Removal of  $\text{Ac}^-$  and phosphate resulted in a rapid rise in  $\text{pH}_i$  ( $ab$ ), followed by a slower decline ( $bc$ ). Readdition of  $\text{Ac}^-$  and phosphate bilaterally caused a small and rapid decrease in  $\text{pH}_i$  ( $cd$ ), followed by a slower increase ( $de$ ). Eight similar experiments were performed.

TABLE I  
*Compositions of Solutions*

Component	1 Standard HEPES	2 0 $\text{Ac}^-$ , 0 $\text{Pi}$ , HEPES	3 0 $\text{Pi}$ , HEPES	4 0 $\text{Ac}^-$ , HEPES	5 0 $\text{Na}^+$ , 0 $\text{Ac}^-$ , HEPES	6 Citrate, HEPES
$\text{Na}^+$	146.4	145.8	146.4	146.4	0	146.4
$\text{K}^+$	5.0	5.0	5.0	5.0	5.0	5.0
NMDG <sup>+</sup>	0	0	0	0	145.8	0
$\text{Mg}^{++}$	1.2	1.2	1.2	1.2	1.2	1.2
$\text{Ca}^{++}$	1.0	1.0	1.0	1.0	1.0	1.0
meq (+)	155.8	155.2	155.8	155.8	155.2	155.8
$\text{Cl}^-$	120.0	135.0	125.6	132.0	131.2	132.0
$\text{H}_2\text{PO}_4^-$	0.4	0	0	0.4	0.4	0.4
$\text{HPO}_4^-$	1.6	0	0	1.6	1.6	1.6
$\text{Ac}^-$	10.0	0	10.0	0	0	0
HEPES <sup>-</sup>	17.8	17.8	17.8	17.8	17.8	17.8
$\text{SO}_4^-$	1.2	1.2	1.2	1.2	1.2	1.2
meq (-)	155.8	155.2	155.8	155.8	155.2	155.8
Glucose	5.5	5.5	5.5	5.5	5.5	5.5
Alanine	5.0	5.0	5.0	5.0	5.0	5.0
HEPES	14.4	14.4	14.4	14.4	14.4	14.4
pH	7.4	7.4	7.4	7.4	7.4	7.4

All concentrations are given in millimolar. NMDG<sup>+</sup>, *N*-methyl-D-glucamine.

$\text{Ac}^-$  and  $\text{Pi}$ ; there is first a transient  $\text{pH}_i$  decline (*cd*), although this is barely evident in the experiment of Fig. 1, and then a slower but sustained  $\text{pH}_i$  increase (*de*) to the value that prevailed before the removal of  $\text{Ac}^-$  and  $\text{Pi}$ .

#### *Bilateral Removal of $\text{Ac}^-$*

To determine which of the two buffer species,  $\text{Ac}^-$  or  $\text{Pi}$ , was responsible for these  $\text{pH}_i$  changes, we next removed either  $\text{Ac}^-$  or  $\text{Pi}$  bilaterally. In the experiment of Fig. 2, bilateral removal of  $\text{Pi}$  only (solution 3) results in a very slight decrease in  $\text{pH}_i$  (*ab*) that is reversed (*bc*) when  $\text{Pi}$  is returned to the external solution. In contrast, bilateral removal of  $\text{Ac}^-$  only (solution 4) results in a transient rise in  $\text{pH}_i$  (*cd*), followed

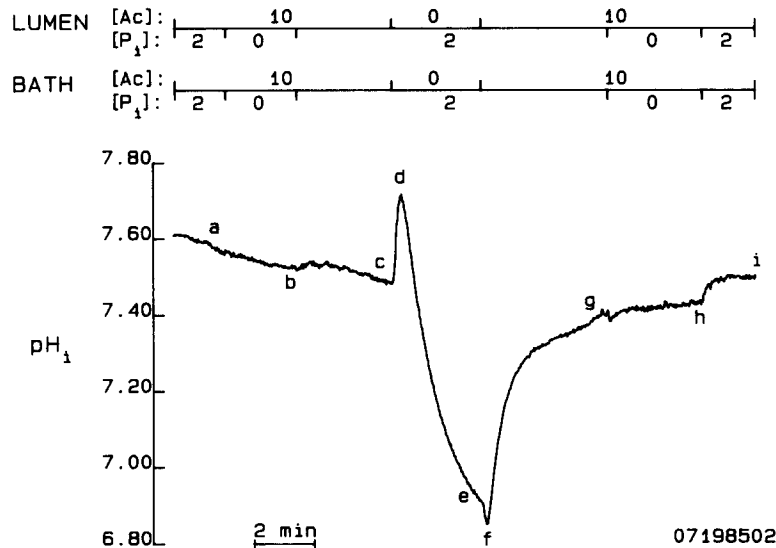

FIGURE 2. Effect on  $\text{pH}_i$  of bilateral removal of either  $\text{Ac}^-$  or phosphate from the external solutions. Bilateral removal of only phosphate caused a very slight acidification (*ab* and *gh*), which was reversed when phosphate was restored (*bc* and *hi*). Bilateral removal of only  $\text{Ac}^-$  caused a rapid, transient rise in  $\text{pH}_i$  (*cd*), followed by a slower decline (*de*). Readdition of  $\text{Ac}^-$  produced the opposite changes in  $\text{pH}_i$  (*efg*). Four similar experiments were performed.

by a slower but profound decrease in  $\text{pH}_i$  (*de*). The  $\text{pH}_i$  changes are reversed upon returning external  $\text{Ac}^-$  (*efg*). These patterns of  $\text{pH}_i$  changes are very similar to those caused by the bilateral removal of both  $\text{Ac}^-$  and  $\text{Pi}$  (see Fig. 1). Later in the experiment of Fig. 2,  $\text{Pi}$  is removed and restored a second time (*ghi*). Comparison of the separate effects of  $\text{Pi}$  and  $\text{Ac}^-$  on  $\text{pH}_i$  in this experiment leads us to conclude that, under the conditions of these experiments,  $\text{Ac}^-$  transport has a much greater ability to affect  $\text{pH}_i$  than  $\text{Pi}$  transport. Moreover, the biphasic  $\text{pH}_i$  transients observed by simultaneously altering both  $[\text{Ac}^-]$  and  $[\text{Pi}]$  (see Fig. 1) can be reproduced by altering only  $[\text{Ac}^-]$ . The rapid but small spiking changes in  $\text{pH}_i$  that accompany  $\text{Ac}^-$  removal (*cd*) and readdition (*ef*) are probably due to the net movement of  $\text{HAc}$  out of or into the cell, respectively. The slow but substantial  $\text{pH}_i$  changes that accom-

pany  $\text{Ac}^-$  removal (*de*) or readdition (*fg*) are presumably due, respectively, to the blockade and reinitiation of an  $\text{Ac}^-$ -dependent acid-extruding process.

#### *Unilateral Removal or Readdition of $\text{Ac}^-$*

*Unilateral removal of  $\text{Ac}^-$ .* To determine the sidedness of  $\text{Ac}^-$  transport, we removed  $\text{Ac}^-$  from either the lumen or the bath. As shown in Fig. 3, removal of  $\text{Ac}^-$  from the lumen only (solution 4) causes a transient rise in  $\text{pH}_i$  (*ab*) that is followed by a large and sustained fall, very similar to the changes caused by removal of  $\text{Ac}^-$  from both lumen and bath (see Figs. 1 and 2). Restoration of luminal  $\text{Ac}^-$  causes  $\text{pH}_i$  to

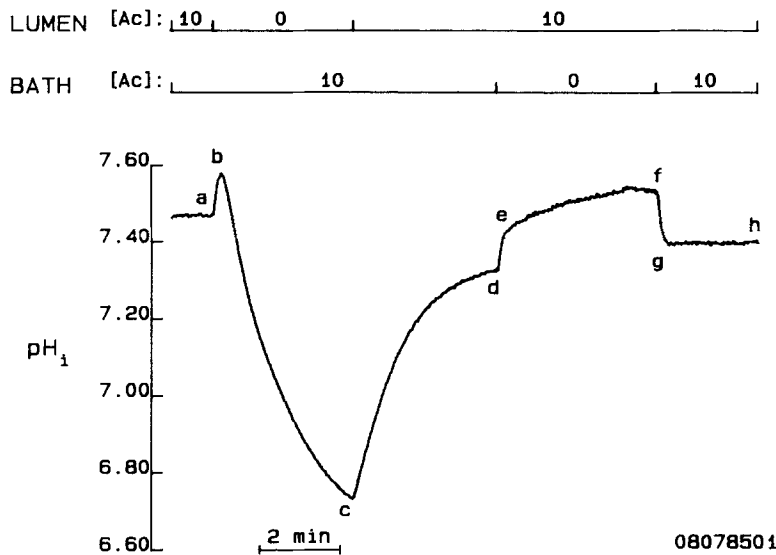

FIGURE 3. Effect on  $\text{pH}_i$  of unilateral removal of  $\text{Ac}^-$ . Removal of  $\text{Ac}^-$  from only the lumen caused a transient rise in  $\text{pH}_i$  (*ab*), followed by a slower decline (*bc*). Readdition of  $\text{Ac}^-$  to lumen caused the opposite changes in  $\text{pH}_i$  (*cd*). Removal of  $\text{Ac}^-$  from only the bath caused  $\text{pH}_i$  to increase rapidly (*de*), and then to continue to increase very slowly (*ef*). Readdition of  $\text{Ac}^-$  to bath caused a rapid decrease in  $\text{pH}_i$  (*fg*). Five similar experiments were performed.

recover promptly (*cd*). One might expect the readdition of luminal  $\text{Ac}^-$  to cause a small transient acidification, as observed for the bilateral addition of  $\text{Ac}^-$  in the experiment of Fig. 2. However, such an acidification generally was not observed when the  $\text{pH}_i$  prevailing before the addition of  $\text{Ac}^-$  was relatively low ( $<6.8$ ). This is to be expected if the transient acidification is due to the influx of HAc, inasmuch as the dissociation of intracellular HAc into  $\text{H}^+$  and  $\text{Ac}^-$  is reduced at a low  $\text{pH}_i$ . Note that the  $\text{pH}_i$  prevailing before the removal of luminal  $\text{Ac}^-$  (point *a*) is higher than the final  $\text{pH}_i$  after luminal  $\text{Ac}^-$  is returned (*d*). This implies that, during the period of luminal  $\text{Ac}^-$  removal (*ac*), when  $\text{Ac}^-$  was still present in the bath, there was a net accumulation of acid by the proximal-tubule cells.

In the same tubule, when  $\text{Ac}^-$  is removed from the bath only, there is a rapid rise in  $\text{pH}_i$  (*de*), followed by a very slow upward drift (*ef*). Readdition of  $\text{Ac}^-$  to the bath

solution reverses this effect, causing  $\text{pH}_i$  to quickly fall (*fg*) and then stabilize (*gh*). Note that the  $\text{pH}_i$  prevailing before the removal of basolateral  $\text{Ac}^-$  (*d*) is lower than that prevailing after the return of basolateral  $\text{Ac}^-$  (*gh*). This implies that during the period of basolateral  $\text{Ac}^-$  removal, when  $\text{Ac}^-$  was still present in the lumen, there was a net depletion of acid from the proximal-tubule cells.

*Provisional model.* The data presented thus far can be accounted for by the following working model. We propose that the proximal-tubule cell has a pathway for HAC transport at both the luminal and basolateral membranes. This pathway could permit simple nonionic diffusion of HAC, or be a transporter (e.g., a  $\text{H}^+/\text{Ac}^-$  cotransporter or an  $\text{Ac}^-/\text{base}$  exchanger). In addition, we propose that the proximal-tubule cell possesses a  $\text{Na}^+$ -dependent pathway for  $\text{Ac}^-$  transport at the luminal membrane only, as suggested by the data of the preceding paper (Nakhoul et al., 1988). Under normal conditions, the action of this luminal  $\text{Na}^+/\text{Ac}^-$  cotransporter and the HAC pathways would be to alkalinize the cell. According to this model, the rapid  $\text{pH}_i$  increase caused by the removal of luminal  $\text{Ac}^-$  in the experiment of Fig. 3 (*ab*) is due to the efflux of HAC across the luminal membrane. The slower fall in  $\text{pH}_i$  (*bc*) is caused by two factors. First, in the absence of luminal  $\text{Ac}^-$ , the  $\text{Na}^+/\text{Ac}^-$  cotransporter can no longer participate in alkalinizing the cell. The underlying production of acid thus causes  $\text{pH}_i$  to fall. Second, HAC continues to enter across the basolateral membrane, and dissociate into  $\text{Ac}^-$  and  $\text{H}^+$ . The former leaves the cell via the luminal  $\text{Na}^+/\text{Ac}^-$  cotransporter, whereas the latter is trapped inside, thereby further acidifying the cell. Thus, there is a net accumulation of acid within the cell during the period of luminal  $\text{Ac}^-$  removal.

Returning  $\text{Ac}^-$  to the lumen causes a small (inapparent) acidification due to the entry of HAC, followed by a  $\text{pH}_i$  recovery (*cd*). This intracellular alkalinization can occur only as the result of two separate transport processes. The entry of  $\text{Ac}^-$  across the luminal membrane can by itself raise  $\text{pH}_i$  only by a trivial amount, inasmuch as the  $\text{pK}$  for the reaction  $\text{Ac}^- + \text{H}^+ \rightleftharpoons \text{HAc}$  (i.e.,  $\sim 4.8$ ) is far lower than the prevailing  $\text{pH}_i$  (i.e.,  $\sim 7.0$ ). However, the entering  $\text{Ac}^-$  can exit the cell together with a  $\text{H}^+$  across both the luminal and basolateral membranes, thereby causing the  $\text{pH}_i$  increase observed during *cd*. The effects of basolateral  $\text{Ac}^-$  removal can be similarly explained. The rapid  $\text{pH}_i$  increase (*de*) is due to the efflux of HAC across the basolateral membrane. However, intracellular HAC is replenished by the entry of  $\text{Ac}^-$  across the luminal membrane and its subsequent protonation. Thus, HAC continues to slowly exit across the basolateral membrane, and the cell slowly alkalinizes (*ef*).

*Unilateral Readdition of  $\text{Ac}^-$ .* To examine this hypothesis further, we performed an additional set of experiments in which  $\text{Ac}^-$  was first removed from both the lumen and bath, and then returned either to the lumen or to the bath. As shown in Fig. 4, bilateral removal of  $\text{Ac}^-$  leads to the usual rapid alkalinization (*ab*), followed by a slower acidification (*bc*). Readdition of  $\text{Ac}^-$  to only the bath causes a sustained drop in  $\text{pH}_i$  (*cd*). This acidification should have two components. First, the basolateral influx and dissociation of HAC causes a small, rapid acidification that is difficult to discern. Second, the continuing basolateral influx of HAC, its intracellular dissociation into  $\text{H}^+$  and  $\text{Ac}^-$ , and the luminal exit of  $\text{Ac}^-$  causes a sustained fall of  $\text{pH}_i$ . The removal of  $\text{Ac}^-$  from the bath causes a slight alkalinization (*de*), which is caused by the basolateral efflux of HAC. Note that the  $\text{pH}_i$  prevailing before the addition of basolateral  $\text{Ac}^-$  (*c*) is substantially higher than the final  $\text{pH}_i$  value after the removal

of the  $\text{Ac}^-$  (*e*). This reflects the intracellular accumulation of acid during the exposure to basolateral  $\text{Ac}^-$  (*cd*).

When  $\text{Ac}^-$  is added only to the lumen, there is a rapid but small acidification (*fg*), followed by a slower but sustained alkalization (*gh*). The transient  $\text{pH}_i$  decrease is due to the luminal influx of HAc, whereas the sustained  $\text{pH}_i$  increase presumably is caused by the luminal entry of  $\text{Ac}^-$ , followed by the bilateral exit of HAc. Thus, the data from the experiments of Figs. 3 and 4 are consistent with the model of a  $\text{Na}^+/\text{Ac}^-$  cotransporter at the luminal membrane, and bilateral pathways for HAc transport.

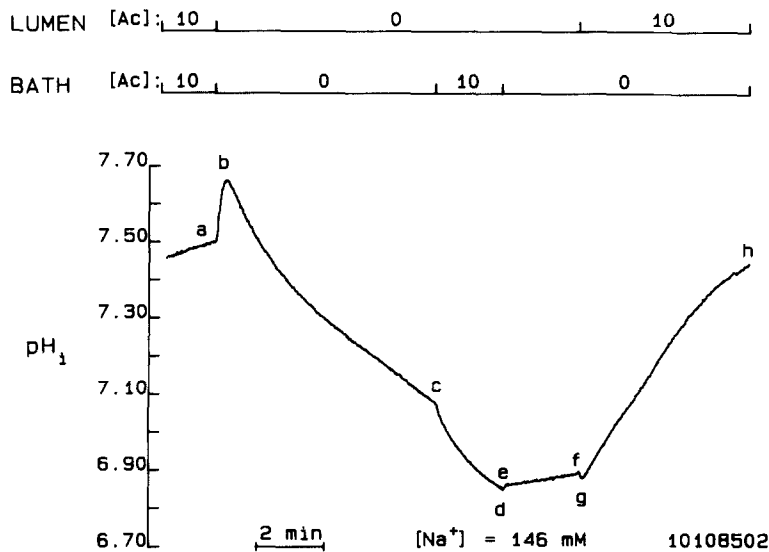

FIGURE 4. Effect on  $\text{pH}_i$  of unilateral addition of  $\text{Ac}^-$ . As a preliminary step,  $\text{Ac}^-$  was removed bilaterally, causing the usual sequence of  $\text{pH}_i$  changes (*abc*). Addition of  $\text{Ac}^-$  to only the bath caused a sustained drop in  $\text{pH}_i$  (*cd*). Removal of  $\text{Ac}^-$  from the bath caused a rapid but slight rise in  $\text{pH}_i$  (*de*), followed by a very slight alkalization (*ef*). Adding  $\text{Ac}^-$  to only the lumen caused a rapid, small decrease in  $\text{pH}_i$  (*fg*), followed by a slower increase (*gh*). Three similar experiments were performed.

#### *Na<sup>+</sup> Dependence of the Luminal $\text{Ac}^-$ Transport System*

Our working model makes several predictions concerning experiments of the type shown in Figs. 3 and 4. First, the rapid spiking changes in  $\text{pH}_i$  caused by changes in luminal or basolateral  $[\text{Ac}^-]$ , which we attribute to HAc fluxes, should not depend upon the presence of external  $\text{Na}^+$ . Second, the  $\text{pH}_i$  recovery caused by the addition of  $\text{Ac}^-$  to the lumen should not depend upon the presence of  $\text{Na}^+$  in the bath, as long as  $\text{Na}^+$  is present in the lumen. Third, the  $\text{pH}_i$  recovery caused by the addition of  $\text{Ac}^-$  to the lumen should be completely blocked by removal of  $\text{Na}^+$  from the lumen, whether or not  $\text{Na}^+$  is present in the bath. In the following experiments we have examined each of these predictions.

*The effect of adding basolateral  $\text{Ac}^-$  in the bilateral absence of  $\text{Na}^+$ .* In the experiment of Fig. 5, both  $\text{Na}^+$  and  $\text{Ac}^-$  are removed from both the lumen and the bath



(solution 5). The resulting transient alkalization (*ab*) can be attributed to the bilateral efflux of HAc. The sustained  $\text{pH}_i$  decline (*bc*) is probably due to the removal of both the  $\text{Ac}^-$  (i.e., blockade and reversal of luminal  $\text{Na}^+/\text{Ac}^-$  cotransport) and the  $\text{Na}^+$  (i.e., blockade and reversal of  $\text{Na}^+/\text{H}^+$  exchange). When  $\text{Ac}^-$  is then returned only to the bath, in the continued bilateral absence of external  $\text{Na}^+$ ,  $\text{pH}_i$  rapidly falls by a small amount (*cd*), recovers somewhat, and then levels off (*de*). The subsequent removal of basolateral  $\text{Ac}^-$  produces a rapid, but small alkalization (*ef*). Finally, when  $\text{Na}^+$  is returned to the lumen only, in the continued bilateral absence of exter-

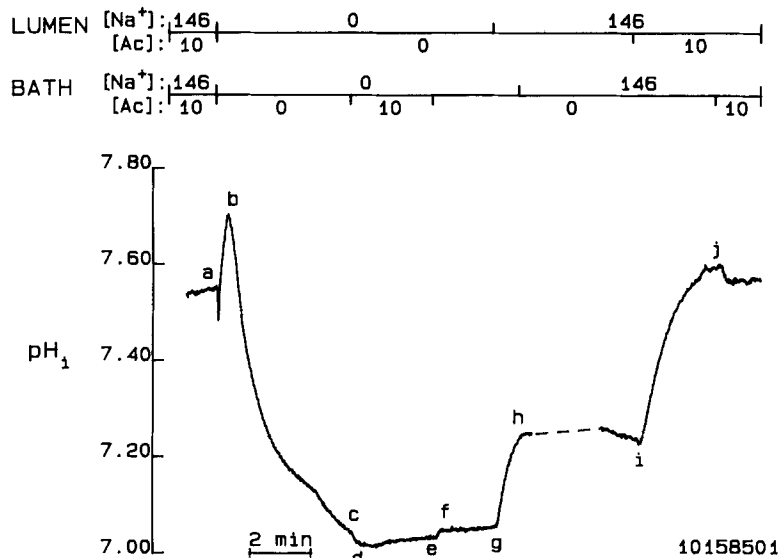

FIGURE 5. Effect on  $\text{pH}_i$  of adding  $\text{Ac}^-$  to only the bath in the absence of external  $\text{Na}^+$ . Initially,  $\text{Na}^+$  and  $\text{Ac}^-$  were removed bilaterally, resulting in the usual  $\text{pH}_i$  transients (*abc*). Addition of  $\text{Ac}^-$  to only the bath caused a small decrease in  $\text{pH}_i$  (*cd*), followed by a slight recovery (*de*). Subsequent removal of  $\text{Ac}^-$  from the bath caused the  $\text{pH}_i$  to increase slightly (*ef*), and then stabilize (*fg*). When  $\text{Na}^+$  was restored to the lumen,  $\text{pH}_i$  recovered rapidly but only partially (*gh*). The addition of  $\text{Na}^+$  to the bath had only a slight effect on  $\text{pH}_i$  (*hi*). During the period indicated by the broken line, we were unable to collect data because of an air bubble in the chamber. The addition of  $\text{Ac}^-$  to the lumen, in the bilateral presence of  $\text{Na}^+$ , resulted in a rapid  $\text{pH}_i$  recovery (*ij*), whereas the subsequent addition of  $\text{Na}^+$  to the bath (*j*) caused a small sustained acidification. Three similar experiments were performed.

nal  $\text{Ac}^-$ ,  $\text{pH}_i$  rapidly increases (*gh*), but does not fully recover to its initial value (*a*). The addition of  $\text{Na}^+$  to the bath is not shown, but produced only a small  $\text{pH}_i$  shift. The complete recovery of  $\text{pH}_i$  occurs only when  $\text{Ac}^-$  is returned to the lumen in the presence of  $\text{Na}^+$  (*ij*).

The rapid  $\text{pH}_i$  changes accompanying the application (*cd*) and removal (*ef*) of basolateral  $\text{Ac}^-$  in the experiment of Fig. 5 presumably are due to the fluxes of HAc across the basolateral membrane, and are very similar to those elicited by changes in basolateral  $\text{Ac}^-$  in the presence of external  $\text{Na}^+$  (e.g., see *de* of Fig. 4). Thus, as

predicted by the model, these HAc fluxes are not  $\text{Na}^+$ -dependent. On the other hand, the relative stability of  $\text{pH}_i$  during segment *de* in the experiment of Fig. 5, conducted in the absence of  $\text{Na}^+$ , is in marked contrast to the rapid  $\text{pH}_i$  decline observed in experiments in which the cells were exposed to basolateral  $\text{Ac}^-$  in the presence of  $\text{Na}^+$  (see segment *cd* of Fig. 4). Thus, these results are consistent with the hypothesis that the mechanism for luminal  $\text{Ac}^-$  exit is blocked by the bilateral removal of  $\text{Na}^+$ . The  $\text{pH}_i$  recovery elicited by the addition of luminal  $\text{Na}^+$  in the absence of  $\text{Ac}^-$  (*gh*) is probably due to luminal  $\text{Na}^+/\text{H}^+$  exchange (Nakhoul et al., 1988). The  $\text{pH}_i$  recovery that accompanies the addition of  $\text{Ac}^-$  to the lumen in the

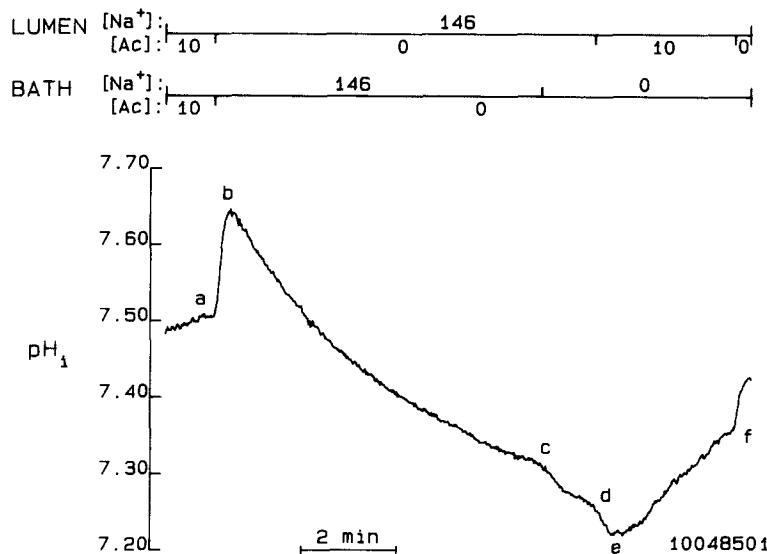

FIGURE 6. Effect on  $\text{pH}_i$  of adding  $\text{Ac}^-$  to only the lumen in the basolateral absence of  $\text{Na}^+$  and  $\text{Ac}^-$ . In a first preliminary step,  $\text{Ac}^-$  was removed bilaterally, causing the usual series of  $\text{pH}_i$  changes (*abc*). In a second preliminary step,  $\text{Na}^+$  was removed from the bath (*cd*). When  $\text{Ac}^-$  then was added to the lumen,  $\text{pH}_i$  rapidly decreased by a small amount (*de*), and then increased more slowly (*ef*). Three similar experiments were performed.

presence of  $\text{Na}^+$  (*ij*) probably reflects the effect of luminal  $\text{Na}^+/\text{Ac}^-$  influx in combination with bilateral HAc efflux.

*The effect of adding luminal  $\text{Ac}^-$  in the bilateral absence of  $\text{Na}^+$ .* We also performed four experiments similar to that of Fig. 5 in which 10 mM  $\text{Ac}^-$  was added to and removed from the lumen in the absence of  $\text{Na}^+$  (data not shown). When  $\text{Ac}^-$  is added to the lumen only,  $\text{pH}_i$  abruptly declines and then fails to recover (similar to *cde* of Fig. 5). When the  $\text{Ac}^-$  is removed,  $\text{pH}_i$  rapidly rises a small amount (similar to *ef*). The abrupt  $\text{pH}_i$  changes that occur in the absence of  $\text{Na}^+$  provide further evidence that luminal HAc transport is  $\text{Na}^+$ -independent, whereas the failure of luminal  $\text{Ac}^-$  to elicit a  $\text{pH}_i$  recovery in the absence of  $\text{Na}^+$  indicates that the luminal uptake of  $\text{Ac}^-$  is  $\text{Na}^+$  dependent.

*The effect of adding luminal  $\text{Ac}^-$  in the absence of bath  $\text{Na}^+$ .* In another series of experiments, we added  $\text{Ac}^-$  only to the lumen when  $\text{Na}^+$  was present in the lumen

but not in the bath. As shown in Fig. 6, bilateral removal of external  $\text{Ac}^-$  results in the usual  $\text{pH}_i$  changes (*abc*). The removal of  $\text{Na}^+$  from only the bath causes an additional small  $\text{pH}_i$  decrease (*cd*). This acidification could reflect blockade or reversal of a  $\text{Na}^+$ -dependent acid-extruding process (e.g.,  $\text{Na}^+/\text{H}^+$  exchange) at the basolateral membrane. When  $\text{Ac}^-$  is then returned only to the lumen, in the continued absence of bath  $\text{Na}^+$ ,  $\text{pH}_i$  transiently falls (*de*, due to luminal HAc influx), but then recovers (*ef*). These  $\text{pH}_i$  changes (*def*) are very similar to those that are routinely observed in the presence of bath  $\text{Na}^+$  (see *cd* of Fig. 3 and *fgh* of Fig. 4), and indicate that the  $\text{pH}_i$  recovery caused by the addition of luminal  $\text{Ac}^-$  does not require the presence of  $\text{Na}^+$  in the bath. Note that in the experiment of Fig. 6, the intracellular  $\text{Na}^+$

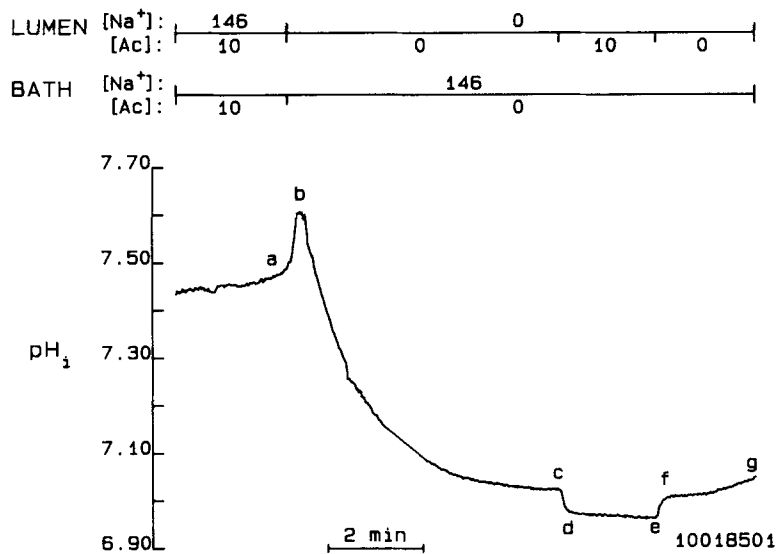

FIGURE 7. Luminal- $\text{Na}^+$  dependence of the  $\text{pH}_i$  increase induced by addition of luminal  $\text{Ac}^-$ . Initially, the bilateral removal of  $\text{Ac}^-$  and the luminal removal of  $\text{Na}^+$  caused the usual  $\text{pH}_i$  changes (*abc*). Readdition of  $\text{Ac}^-$  to only the lumen, in the continued absence of luminal  $\text{Na}^+$ , caused a rapid but slight  $\text{pH}_i$  decrease (*cd*), but no recovery (*de*). These changes were reversed by removal of the  $\text{Ac}^-$ . Four similar experiments were performed.

activity is likely to be lower than normal, due to the absence of bath  $\text{Na}^+$ ; this does not appear to have a major effect on the luminal  $\text{Ac}^-$ -induced  $\text{pH}_i$  recovery (*ef*).

*The effect of adding luminal  $\text{Ac}^-$  in the absence of luminal  $\text{Na}^+$ .* To determine whether the luminal  $\text{Ac}^-$ -induced  $\text{pH}_i$  recovery is specifically blocked by the removal of luminal  $\text{Na}^+$ , we performed the experiment of Fig. 7. Bilateral removal of  $\text{Ac}^-$ , and the luminal removal of  $\text{Na}^+$ , cause the usual  $\text{pH}_i$  changes (*abc*).  $\text{Na}^+$  is maintained in the bath solution throughout the experiment. When  $\text{Ac}^-$  is returned to the luminal perfusate, in the continued absence of luminal  $\text{Na}^+$ ,  $\text{pH}_i$  rapidly falls by a small amount (*cd*) and remains at that level (*de*). Removal of luminal  $\text{Ac}^-$  had the opposite effect (*ef*). Note that the usual  $\text{pH}_i$  recovery that follows the rapid luminal  $\text{Ac}^-$ -induced acidification (e.g., *fgh* of Fig. 4 and *def* of Fig. 6) is completely abol-

ished in the absence of luminal  $\text{Na}^+$ . All that remains are the rapid  $\text{pH}_i$  changes (*cd* and *ef*) that we attribute to HAc fluxes across the luminal membrane.

The above observations are consistent with our hypothesis that there are two components of  $\text{Ac}^-$  transport in the S3 segment of the rabbit proximal tubule. The first is the movement of HAc across the luminal and basolateral membranes. This component is independent of  $\text{Na}^+$ , and causes rapid but small changes in  $\text{pH}_i$ . The second component is a  $\text{Na}^+$ -dependent pathway for  $\text{Ac}^-$  across only the luminal membrane. We propose that when the combined gradient for  $\text{Na}^+$  and  $\text{Ac}^-$  are in the inward direction, this transporter promotes a sustained  $\text{pH}_i$  increase, whereas if this combined gradient is outward, it promotes a sustained  $\text{pH}_i$  decrease.

#### *Dependence of the $\text{Ac}^-$ -dependent $\text{pH}_i$ Changes on $\text{Ac}^-$ Concentration*

Having established that the addition and removal of 10 mM  $\text{Ac}^-$  (a concentration commonly used in experiments on mammalian renal tubules) has a profound effect on  $\text{pH}_i$ , we next tried to determine whether lower concentrations of  $\text{Ac}^-$  have similar effects. In the following experiments,  $\text{Ac}^-$  was removed from the lumen and the bath, and then varied concentrations of  $\text{Ac}^-$  were added back to the lumen only. As shown in Fig. 8 A, bilateral removal of  $\text{Ac}^-$  resulted in the usual  $\text{pH}_i$  changes (*abc*). Readdition of 1 mM  $\text{Ac}^-$  to the lumen produced a prompt  $\text{pH}_i$  recovery (*cd*), which was reversed upon removal of luminal  $\text{Ac}^-$  (*de*). Note the absence at point *c* of the transient  $\text{pH}_i$  fall that normally accompanies addition of 10 mM  $\text{Ac}^-$ , as well as the absence of the transient  $\text{pH}_i$  increase at point *d* that normally accompanies removal of 10 mM  $\text{Ac}^-$ . These rapid  $\text{pH}_i$  transients, which we attribute to fluxes of HAc, presumably are absent in these 1-mM- $\text{Ac}^-$  experiments, inasmuch as the prevailing extracellular [HAc] is only one tenth as great as in solutions containing 10 mM  $\text{Ac}^-$ . Indeed, when 10 mM  $\text{Ac}^-$  is added to the lumen of the same tubule, the usual transient fall in  $\text{pH}_i$  is observed (*ef*) and is followed by a  $\text{pH}_i$  recovery that is no faster than in the presence of 1 mM  $\text{Ac}^-$  (*fg*). Removal of 10 mM luminal  $\text{Ac}^-$  causes the usual transient  $\text{pH}_i$  increase (*gh*), followed by a sustained acidification (*hi*).

In the experiment of Fig. 8 B, we examined the effect of adding even lower concentrations of  $\text{Ac}^-$  to the lumen of a tubule from which  $\text{Ac}^-$  had previously been removed from both the lumen and bath. The initial rate of alkalization produced by 0.2 mM  $\text{Ac}^-$  (*ab*) was only about 40% as great as that produced by 1.0 mM  $\text{Ac}^-$  (*cd*) when both are measured at  $\text{pH}_i$  of 7.0. In four paired experiments the rate of alkalization produced by 0.2 mM  $\text{Ac}^-$  was  $46 \pm 7\%$  of that produced by 1 mM  $\text{Ac}^-$ . We conclude that, to avoid the alkalizing effect of luminal  $\text{Ac}^-$  in nominally  $\text{HCO}_3^-$ -free solutions, extracellular  $[\text{Ac}^-]$  would have to be lowered substantially below 1 mM, and even concentrations as low as 0.2 mM can be expected to produce a substantial steady-state alkalization.

#### *Effect of Luminal Citrate on $\text{pH}_i$*

In an attempt to find a metabolizable carboxylate that does not produce a substantial alkalization in the nominal absence of  $\text{HCO}_3^-$ , we tested citrate, a tricarboxylate. Evidence from membrane vesicle experiments indicates that citrate is not transported by the  $\text{Na}^+$ /monocarboxylate cotransporter that mediates fluxes of  $\text{Ac}^-$ , but rather by a  $\text{Na}^+$ -dependent transporter highly specific for intermediates of the tri-

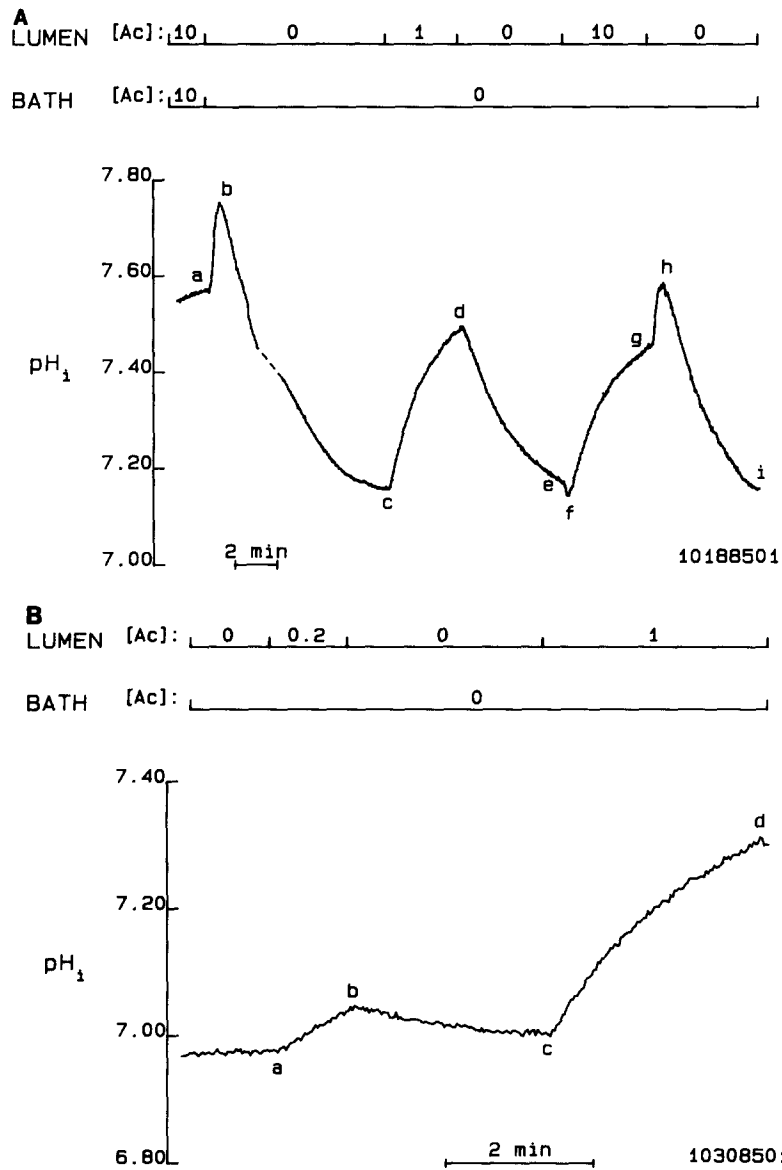

FIGURE 8. Effect of lower concentrations of luminal  $\text{Ac}^-$  on the  $\text{Ac}^-$ -induced alkalization. (A) Comparison of 1 and 10 mM luminal  $\text{Ac}^-$ . After the initial bilateral removal of  $\text{Ac}^-$ , which caused the usual  $\text{pH}_i$  changes (*abc*), adding 1 mM  $\text{Ac}^-$  to the lumen caused the cell to alkalinize (*cd*) at a rate that was as fast as the alkalization induced by the addition of 10 mM  $\text{Ac}^-$  (*fg*). Note that the addition of 10 mM  $\text{Ac}^-$  caused an initial  $\text{pH}_i$  decrease (*ef*), whereas the addition of 1 mM  $\text{Ac}^-$  did not. Seven similar experiments were performed. (B) Comparison of 0.2 and 1 mM  $\text{Ac}^-$ . After the bilateral removal of  $\text{Ac}^-$  (not shown), the addition of 0.2 mM  $\text{Ac}^-$  caused a  $\text{pH}_i$  recovery (*ab*) that, in five similar experiments, was only about 40% as fast as that elicited by the addition of 1 mM  $\text{Ac}^-$  (*cd*). The experiments of A and B were performed on different tubules.

carboxylic acid cycle (Kippen et al., 1979). This latter system does not appear to transport monocarboxylates (Wright et al., 1980), and its effects on  $\text{pH}_i$  are unclear. In the experiment of Fig. 9,  $\text{Ac}^-$  is first removed from both the lumen and the bath, which results in the usual  $\text{pH}_i$  changes (*abc*). When 5 mM citrate (solution 6) is added to the lumen,  $\text{pH}_i$  increases only slightly (*cde*). Removal of the citrate produces no discernible change in  $\text{pH}_i$  (*ef*). Addition (*fg*) and then removal (*gh*) of 5 mM citrate to/from the bath produced, at most, slight  $\text{pH}_i$  changes. Finally, addition of 10 mM  $\text{Ac}^-$  to the lumen produced the usual series of  $\text{pH}_i$  changes (*hij*).

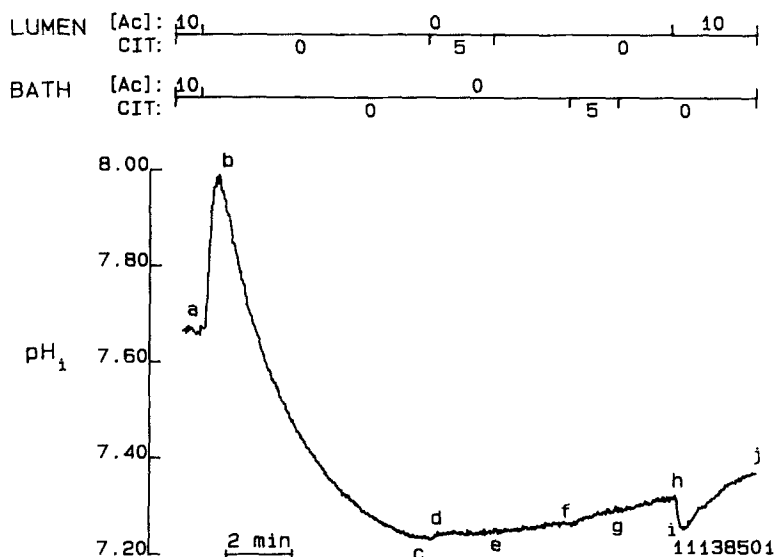

FIGURE 9. Effect of unilateral addition of citrate on  $\text{pH}_i$ . The initial bilateral removal of  $\text{Ac}^-$  caused the usual  $\text{pH}_i$  changes (*abc*). Addition of 5 mM citrate to the lumen caused a slight increase in  $\text{pH}_i$  (*cde*), whereas the removal had a minimal effect (*ef*). Addition of citrate to the bath (*fg*), or its removal (*gh*), also had a negligible effect on  $\text{pH}_i$ . Six similar experiments were performed.

#### DISCUSSION

In the preceding paper (Nakhoul et al., 1988) on the S3 segment of the rabbit proximal tubule, we found that 65% of the  $\text{Na}^+$ -dependent acid extrusion taking place in the nominal absence of  $\text{HCO}_3^-$  requires  $\text{Ac}^-$  and is insensitive to amiloride. A possible explanation for this finding was suggested by the results of a study on the effects of lactate transport on  $\text{pH}_i$  in *Ambystoma* proximal tubules, by Siebens and Boron (1987). These authors showed that there is an electroneutral  $\text{Na}^+$ /lactate cotransporter at the luminal membrane, and a  $\text{H}^+$ /lactate cotransporter (or an equivalent process, such as lactate/base exchange) at the basolateral membrane. Because the normal direction of net transport in the *Ambystoma* cells is apparently a net uptake of  $\text{Na}^+$  and lactate at the luminal membrane, and a net exit of  $\text{H}^+$  and lactate at the basolateral membrane, the net effect would be the transepithelial reabsorption of lactate. In addition, there would be a net uptake of  $\text{Na}^+$  across the luminal membrane and net acid extrusion from the cell across the basolateral membrane. We

undertook the present study to determine if a similar mechanism that involved  $\text{Ac}^-$  might be operative in the rabbit S3 proximal tubule and if it could account for the  $\text{Na}^+$ - and  $\text{Ac}^-$ -dependent acid extrusion previously observed.

The results of the present study indicate that the cells of the S3 segment of the rabbit proximal tubule have a  $\text{Na}^+/\text{Ac}^-$  cotransporter at the luminal membrane, and HAC transport pathways at both the luminal and basolateral membranes (see Fig. 10). It should be noted that the latter could be accounted for by either the nonionic diffusion of HAC, a  $\text{H}^+/\text{Ac}^-$  cotransporter, or an  $\text{Ac}^-$ /base exchanger. We have made no attempt to distinguish among these. Our model predicts that the addition of  $\text{Ac}^-$  to the lumen only should cause two phases of  $\text{pH}_i$  change. The first is a rapid acidification caused by the influx of HAC across the luminal membrane and the subsequent dissociation of this intracellular HAC into  $\text{H}^+$  and  $\text{Ac}^-$ . This net influx of HAC (or an equivalent process) should continue until  $[\text{HAC}]_i$  is equal to  $[\text{HAC}]_l$ .

The second predicted phase of  $\text{pH}_i$  change induced by the addition of  $\text{Ac}^-$  to the lumen is a slower but sustained  $\text{pH}_i$  increase that reaches a level higher than that

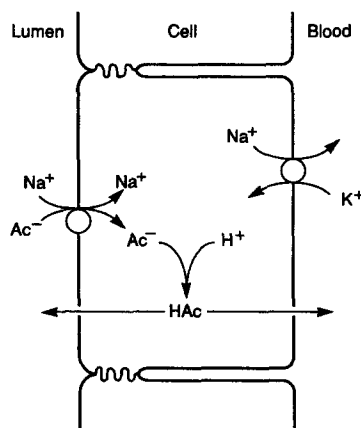

FIGURE 10. Model for  $\text{Ac}^-$  transport by the proximal-tubule cell of the rabbit S3 segment.

prevailing in the absence of  $\text{Ac}^-$ . This  $\text{pH}_i$  increase should occur as the luminal  $\text{Na}^+/\text{Ac}^-$  cotransporter mediates a net uptake of  $\text{Na}^+$  and  $\text{Ac}^-$ , while luminal and basolateral pathways permit the exit of the protonated weak acid HAC. Note that the  $\text{pH}_i$  change requires the activity of two kinds of transport processes. The luminal entry of  $\text{Ac}^-$  by itself is not expected to cause a substantial  $\text{pH}_i$  increase, inasmuch as the  $\text{pK}$  governing the dissociation of HAC is much lower than the prevailing  $\text{pH}_i$ . On the other hand, by themselves, the luminal and basolateral HAC pathways are expected to mediate a rapid, net acidification. Only when the two transporters operate in concert does the luminal application of  $\text{Ac}^-$  result in a  $\text{pH}_i$  increase. We cannot rule out the possibility that a small amount of the  $\text{pH}_i$  increase elicited by the application of luminal  $\text{Ac}^-$  is due to the metabolic consumption of  $\text{Ac}^-$  and  $\text{H}^+$ , rather than to the efflux of HAC. However, our observation, that the application of  $\text{Ac}^-$  to the bath only causes a sustained fall in  $\text{pH}_i$ , suggests that HAC fluxes are far more important for determining  $\text{pH}_i$  than is metabolism.

The net effect of these transport processes can be analyzed from the perspectives

of both  $\text{pH}_i$  regulation and transepithelial transport. Consider a cell possessing luminal  $\text{Na}^+/\text{Ac}^-$  and bilateral HAC cotransport pathways, but no other acid-base transporters. In the steady state, there would be a net influx of  $\text{Na}^+$  across the luminal membrane, and a net efflux of  $\text{H}^+$  across both luminal and basolateral membranes. As far as  $\text{pH}_i$  regulation is concerned, these transporters would appear to be an  $\text{Ac}^-$ -dependent, amiloride-insensitive (see Nakhoul et al., 1988)  $\text{Na}^+$  for  $\text{H}^+$  exchange process that would function as an acid extruder. Indeed, we find that the steady-state  $\text{pH}_i$  is substantially higher in the presence than in the absence of  $\text{Ac}^-$ . The observation that the cells of the rabbit S3 proximal tubule possess two  $\text{Na}^+$ -dependent acid-extrusion mechanisms, an amiloride-sensitive  $\text{Na}^+/\text{H}^+$  exchanger (Nakhoul et al., 1988) and an  $\text{Ac}^-$ -dependent mechanism, raises the question of the relative roles played by each of these mechanisms in  $\text{pH}_i$  homeostasis.

As far as transepithelial transport is concerned, the net effect of  $\text{Na}^+/\text{Ac}^-$  and HAC transport processes depends upon the extent to which HAC exits across the basolateral as opposed to the luminal membrane. First, consider a cell with a luminal  $\text{Na}^+/\text{Ac}^-$  cotransporter, an HAC pathway only at the basolateral membrane, and no other acid-base transporters. Together, the luminal and basolateral  $\text{Ac}^-$  transporters would have three effects: (a) there would be net transepithelial  $\text{Ac}^-$  reabsorption, and (b) an uptake of  $\text{Na}^+$  across the luminal membrane. This is the luminal step of  $\text{Na}^+$  reabsorption; the basolateral step would be mediated by a  $\text{Na}^+$ -extrusion process, such as the Na-K pump. Finally, (c) there would be a net extrusion of  $\text{H}^+$  across the basolateral membrane. This latter effect would oppose the basolateral efflux of  $\text{HCO}_3^-$ , and therefore reduce net acid secretion. This scheme is the one that apparently prevails in the salamander proximal tubule (Siebens and Boron, 1987), where  $\text{Na}^+/\text{lactate}$  cotransport is confined to the luminal membrane, and  $\text{H}^+/\text{lactate}$  cotransport, to the basolateral membrane.

Now consider a cell with a luminal  $\text{Na}^+/\text{Ac}^-$  cotransporter, an HAC pathway confined to the luminal membrane, and no other acid-base transporters. Together, these luminal  $\text{Ac}^-$  transporters would have three effects: (a) there would be no net transport of  $\text{Ac}^-$ ; (b) there would be a net uptake of  $\text{Na}^+$ , which would represent the luminal step of  $\text{Na}^+$  reabsorption, and (c), there would be extrusion of  $\text{H}^+$  across the luminal membrane, which would represent the luminal step of  $\text{H}^+$  secretion and/or  $\text{HCO}_3^-$  reabsorption. This scheme of monocarboxylate shuttling across the luminal membrane was suggested on theoretical grounds by Aronson (1983).

Our data indicate that HAC transport in the rabbit S3 segment occurs at both the luminal and basolateral membranes. Thus, the influence of  $\text{Ac}^-$  on the transepithelial transport of  $\text{Na}^+$ ,  $\text{H}^+$ , and  $\text{Ac}^-$  would be expected to lie between the two extremes described above. Our model predicts that, in the nominal absence of  $\text{HCO}_3^-$ , the addition of  $\text{Ac}^-$  should: (a) alkalinize the cell, (b) promote transepithelial  $\text{Ac}^-$  reabsorption, and (c) promote the secretion of acid into the tubule lumen. Indeed, a preliminary report (Geibel et al., 1987) indicates that, in the nominal absence of  $\text{HCO}_3^-$ ,  $\text{Ac}^-$  promotes the secretion of acid into the lumen of the rabbit S3 segment.

The profound effect of  $\text{Ac}^-$  transport on both steady-state  $\text{pH}_i$  and the rate of  $\text{Na}^+$ -dependent  $\text{pH}_i$  changes suggests that  $\text{Ac}^-$  transport may have important implications for other studies on proximal tubules.  $\text{Ac}^-$  has been employed in several studies on isolated perfused mammalian proximal tubules (Schafer and Andreoli,



1976; Sasaki and Berry, 1984; Biagi, 1985). Our results indicate that  $\text{Ac}^-$  concentrations in the submillimolar range could have a substantial effect on  $\text{pH}_i$  and acid extrusion rates, at least in the nominal absence of  $\text{HCO}_3^-$ . This suggests that the effective  $K_m$  for  $\text{Ac}^-$ -dependent acid extrusion must be rather low. This could be particularly important for the late proximal tubule if there is substantial reabsorption of monocarboxylates earlier in the proximal tubule. Although, in this study, we examined only  $\text{Ac}^-$ , it is likely that other monocarboxylates (e.g., lactate and pyruvate) have effects on  $\text{pH}_i$  similar to those of  $\text{Ac}^-$ .

Finally, this study demonstrates a novel way of assessing  $\text{Ac}^-$  transport. Although using  $\text{pH}_i$  measurements to study  $\text{Ac}^-$  transport is a somewhat indirect approach, the results obtained in this manner reveal information on  $\text{Ac}^-$  transport pathways that would be otherwise inaccessible.

We are indebted to Andrey Yeatts for developing the computer software used in executing the experiments, analyzing the data, and plotting the data. We also thank Emily Tyner for her tireless and cheerful technical assistance, and for preparing the data plots.

This work was supported by National Institutes of Health (NIH) grant DK-30344 (to W.F. Boron), a postdoctoral fellowship from the Connecticut Affiliate of the American Heart Association (to N.L. Nakhoul), and an NIH Research Career Development Award DK-01022 (to W.F. Boron).

*Original version received 25 January 1988 and accepted version received 5 April 1988.*

#### REFERENCES

- Aronson, P. S. 1983. Mechanisms of active  $\text{H}^+$  secretion in the proximal tubule. *American Journal of Physiology*. 245:F647–F659.
- Barac-Nieto, M., H. Murer, and R. Kinne. 1980. Lactate-sodium cotransport in rat renal brush border membranes. *American Journal of Physiology*. 239:F496–F506.
- Biagi, B. A. 1985. Effects of the anion transport inhibitor, SITS, on the proximal straight tubule of the rabbit perfused in vitro. *Journal of Membrane Biology*. 88:25–31.
- Cohen, J. J., and M. Barac-Nieto. 1973. Renal metabolism of substrates in relation to renal function. In *Handbook of Physiology*. S. R. Geiger, editor. American Physiological Society, Washington DC. 909–1001.
- DeHemptinne, A., R. Marrannes, and B. Vanheel. 1983. Influence of organic acids on intracellular pH. *American Journal of Physiology*. 245:C178–C183.
- Geibel, J., W. F. Boron, and G. Giebisch. 1987. Effects of acetate on luminal acidification in the S-3 segment of the rabbit proximal tubule. *Proceedings of the Xth International Congress of Nephrology*. 539. (Abstr.)
- Guder, W. G., S. Wagner, and G. Wirthensohn. 1986. Metabolic fuels along the nephron: pathways and intracellular mechanisms of interaction. *Kidney International*. 29:41–45.
- Gullans, S. R., P. C. Brazy, V. W. Dennis, and L. J. Mandel. 1984. Interactions between gluconeogenesis and sodium transport in rabbit proximal tubule. *American Journal of Physiology*. 246:F859–F869.
- Kahn, A., and P. S. Aronson. 1983. Urate transport via anion exchange in dog renal microvillus membrane vesicles. *American Journal of Physiology*. 244:F56–F63.
- Kippen, I., B. Hirayama, J. R. Klinenberg, and E. M. Wright. 1979. Transport of tricarboxylic acid cycle intermediates by membrane vesicles from renal brush border. *Proceedings of the National Academy of Science*. 76:3397–3400.
- Mandel, L. J. 1985. Metabolic substrates, cellular energy production, and the regulation of proximal tubular transport. *Annual Review of Physiology*. 47:85–101.

- Mengual, R., and P. Sudaka. 1983. The mechanism of Na<sup>+</sup>-L-lactate cotransport by brush border membrane vesicles from horse kidney: analysis of rapid equilibrium kinetics in absence of membrane potential. *Journal of Membrane Biology*. 71:163–171.
- Mudge, G. H. 1951. Studies on potassium accumulation by rabbit kidney slices: effect of metabolic activity. *American Journal of Physiology*. 165:113–127.
- Nakhoul, N. L., A. G. Lopes, J. R. Chaillet, and W. F. Boron. 1988. Intracellular pH regulation in the S3 segment of the rabbit proximal tubule in HCO<sub>3</sub><sup>-</sup>-free solutions. *Journal of General Physiology*. 92:369–393.
- Nord, E. P., S. H. Wright, I. Kippen, and E. M. Wright. 1983. Specificity of the Na<sup>+</sup>-dependent monocarboxylic acid transport pathway in rabbit renal brush border membranes. *Journal of Membrane Biology*. 72:213–221.
- Sasaki, S., and C. A. Berry. 1984. Mechanism of bicarbonate exit across basolateral membrane of the rabbit proximal convoluted tubule. *American Journal of Physiology*. 246:F889–F896.
- Schafer, J. A., and T. E. Andreoli. 1976. Anion transport processes in the mammalian superficial proximal straight tubule. *Journal of Clinical Investigation*. 58:500–513.
- Schild, L., G. Giebisch, L. Karniski, and P. S. Aronson. 1986. Chloride transport in the mammalian proximal tubule. *Pflügers Archiv*. 407:S156–S159.
- Siebens, A. W., and W. F. Boron. 1987. Effect of electroneutral luminal and basolateral lactate transport on intracellular pH in salamander proximal tubules. *Journal of General Physiology*. 90:799–831.
- Spencer, T. L., and A. L. Lehninger. 1976. L-Lactate transport in Ehrlich ascites-tumour cells. *Biochemical Journal*. 154:405–414.
- Thomas, J. A., R. N. Buchsbaum, A. Zimniak, and E. Racker. 1979. Intracellular pH measurements in Ehrlich ascites tumor cells utilizing spectroscopic probes generated in situ. *Biochemistry*. 81:2210–2218.
- Ullrich, K. J., G. Rumrich, and S. Kloss. 1982. Reabsorption of monocarboxylic acids in the proximal tubule of the rat kidney I. Transport kinetics of D-lactate, Na<sup>+</sup>-dependence, pH-dependence and effects of inhibitors. *Pflügers Archiv*. 395:212–219.
- Wright, E. M. 1985. Transport of carboxylic acids by renal membrane vesicles. *Annual Review of Physiology*. 47:127–141.
- Wright, S. H., I. Kippen, J. R. Klinenberg, and E. M. Wright. 1980. Specificity of the transport system for tricarboxylic acid cycle intermediates in renal brush borders. *Journal of Membrane Biology*. 57:73–82.