

## A homozygous female hemophilia A

Preethi S. Nair, S. Shetty, Kanjaksha Ghosh

Department of Thrombosis Haemostasis, National Institute of Immunohaematology, KEM Hospital Campus, Parel, Mumbai, Maharashtra, India

**BACKGROUND:** Hemophilia A (HA), being an X-linked recessive disorder, females are rarely affected, although they can be carriers.

**AIMS:** To study the mutation in *F8* gene in an extended family with a homozygous female HA.

**MATERIALS AND METHODS:** All the seven affected members (six males and one female) were initially screened by Conformation Sensitive Gel Electrophoresis (CSGE) and direct DNA sequencing.

**RESULTS:** A homozygous missense mutation c.1315G>A (p.Gly420Ser) was identified in exon 9 of *F8* gene in homozygous state in the affected female born of 1<sup>o</sup> consanguineous marriage and in all the affected male members of the family. Her factor VIII levels was found to be 5.5%, vWF:Ag 120%.

**CONCLUSION:** In India, as consanguineous marriages are very common in certain communities (up to 30%), the likelihood of encountering female hemophilia is higher, although this is the first case of HA out of 1600 hemophilia families registered in our Comprehensive Haemophilia Care Center. Genetic diagnosis in such cases is not necessary as all the male children will be affected and daughters obligatory carriers.

**Key words:** Consanguinity, factor VIII, female hemophilia, India

by a wide range of heterogeneous mutations in the factor 8 (*F8*) gene.<sup>[1]</sup> Being an X-linked recessive disorder, females are generally not affected, although they can be carriers of this disorder. A classical female hemophilia is possible only when a carrier female marries a hemophilic male, of which there are only few reports in the literature.<sup>[2-4]</sup> Few other reports of homozygous female HA are mainly due to *de novo* mutations in one or both the X chromosomes.<sup>[5,6]</sup>

### Materials and Methods

Blood was collected by peripheral venous puncture at a 1:10 volume ratio in 3.8% trisodium citrate. Activated partial thromboplastin time (aPTT) was determined according to standard techniques. Factor VIII activity (FVIII:C) of each sample was determined by one-stage aPTT-based assay in a semiautomated coagulometer (Diagnostica Stago, Asnieres, France). FVIII inhibitor activity was determined using Bethesda assay. Plasma von Willebrand factor antigen level (vWF:Ag) was measured by enzyme-linked immunosorbent assay (Diagnostica Stago). DNA was extracted using the phenol–chloroform extraction method. Multiplex polymerase chain reactions spanning all the 26 exons were carried out<sup>[7]</sup> and conformation-sensitive gel electrophoresis (CSGE)<sup>[8]</sup> was used to screen the mutations. Amplicons were run on a 12.5% gel (acrylamide: 1, 4-bis acryloyl piperazine – 99:1) incorporating mild denaturants (10%) ethylene glycol, 15% formamide and electrophoresed overnight at 80V. Samples with altered mobility were subjected to DNA sequencing to confirm the mutation. DNA sequencing was performed on both strands using the Big Dye Terminator Cycle Sequencing V1.1 Ready

### Introduction

Hemophilia A (HA) results from the partial or complete deficiency of functional factor VIII (FVIII) protein caused

Access this article online	
Quick Response Code:	Website: www.ijhg.com
	DOI: 10.4103/0971-6866.96685

**Address for correspondence:** Dr. Kanjaksha Ghosh, National Institute of Immunohaematology (ICMR), 13<sup>th</sup> Floor, NMS Building, KEM Hospital Campus, Parel, Mumbai - 400 012, Maharashtra, India. E-mail: kanjakshaghosh@hotmail.com

Reaction kit and an automated ABI DNA sequencer (Applied Biosystems, Carlsbad, California, U.S.A).

## Results

We report a case of homozygous female HA with moderate FVIII deficiency (moderate FVIII deficiency 5.5% FVIII:C, vWF:Ag 120%), born of a 1<sup>o</sup> consanguineous marriage. She presented to our center with severe bleeding diathesis following delivery of her first child and a history of prolonged bleed from cuts and injuries. The mother (a carrier of HA) of the proband was married to a hemophilic who died of excessive bleeding in a road accident and was undiagnosed but his two brothers were diagnosed with moderate deficiency of HA (F VIII:C 4.8% and 5.7%). Her two brothers were affected and the sister was found to be a carrier of HA.

Figure 1 shows the family pedigree of this patient.

Sequencing of this exon revealed a missense mutation

corresponding to c.1315G>A, which results in the amino acid substitution corresponding to p.Gly420Ser that fits well with the clinical manifestation of the patient [Figure 2]. The mother was shown to be a heterozygous carrier of the mutation, while the two affected brothers, uncles and nephews also showed the same mutation. They were found to be cross-reacting material (CRM) negative [Table 1].

## Discussion

It was inferred that the father of this index case was also affected and carried the same mutation as that of the index case. The mutation has earlier been reported to be associated with moderate and severe HA, causing polarity change in the protein coil thus influencing the secondary structure of the protein.<sup>[9]</sup>

Female carriers of HA normally do not exhibit a moderate to severe phenotypic expression of the

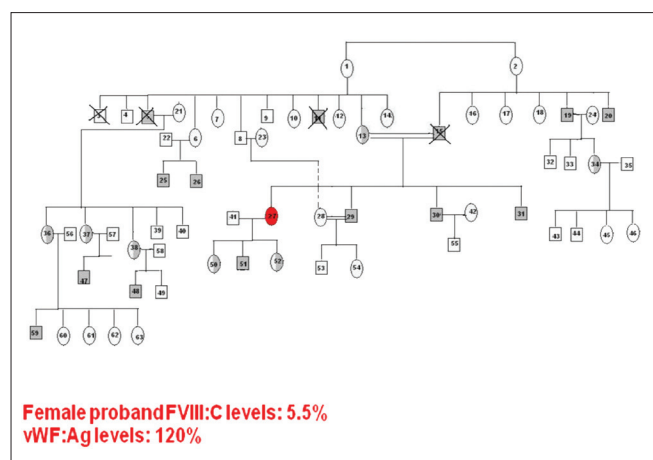

Figure 1: Pedigree of an extensive family with classical female hemophilia A

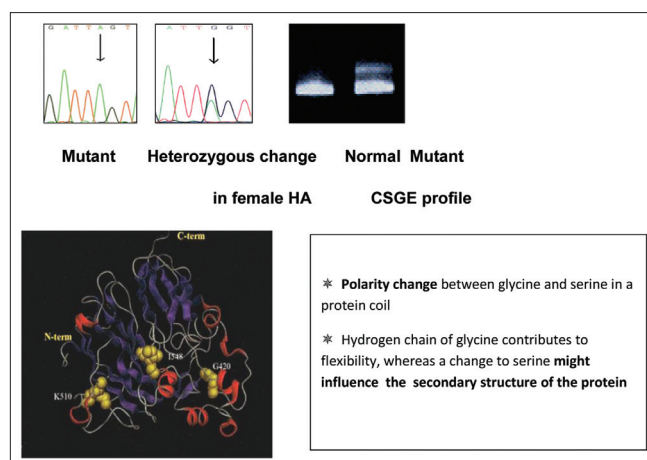

Figure 2: A missense mutation c.1315G>A (p.Gly420Ser) in moderate hemophilia A

Table 1: Genotypic–phenotypic correlation

Bld grp	Sex	FVIII:C levels (%)	FVIII:Ag levels (%)	CRM status	vWF:Ag levels (%)	Factor V Leiden mutation	ETP (nM)	Time to peak (min)	Lag time (min)
<b>O+</b>	<b>Female</b>	<b>5.5</b>	<b>2.0</b>	<b>Neg</b>	<b>120</b>	<b>Normal</b>	<b>1688</b>	<b>5.33</b>	<b>2.17</b>
A-	Male	5.0	1.5	Neg	90	Normal	1942	7.0	2.33
A+	Male	4.1	2.4	Neg	130	Normal	1960	6.5	2.5
A-	Female	60	ND	ND	120	Normal	887.5	10.33	5.17
A+	Female	85	ND	ND	130	Normal	1205	8.5	5.0
O+	Female	62	ND	ND	90	Normal	1224	9.5	5.67
ND	Male	1.8	6.5	Neg	107	Hetero	2123.5	6.0	2.67
ND	Male	3.5	ND	ND	82	Normal	ND	ND	ND
ND	Male	2.0	ND	ND	82	Normal	ND	ND	ND

Text in bold is the classical female hemophilic, ND: Not done, ETP: Endogenous thrombin potential, CRM: Cross-reacting material

disease. However, a number of other pathophysiological mechanisms may account for the phenotypic expression of very low FVIII:C levels in females. These include (i) skewed inactivation of the X chromosome leading to predominant expression of the mutated allele as a result of a preferential inactivation of the X chromosome with the wild-type F8 gene,<sup>[10]</sup> (ii) Turner syndrome, (iii) translocation or (iv) males with a female phenotype due to mutation in the sex-determining region Y (SRY) gene on the Y chromosome, i.e. Swyer syndrome combined with a mutation in the *F8* gene.

In the present report, we have presented homozygosity of the *F8* gene mutation resulting in clinical manifestation of HA in a female. In India, as consanguineous marriages are very common in certain communities (up to 30%), the likelihood of encountering female hemophilia is higher, although this is the first case of HA encountered out of 1600 hemophilia families registered in our Comprehensive Haemophilia Care center. Genetic diagnosis in such cases is not necessary as all the male children will be affected and daughters are obligatory carriers.

### Acknowledgment

The authors wish to express their gratitude for The Lady Tata Senior Fellowship, granted by The Lady Tata Memorial Trust, Mumbai, to one of the authors (P. Nair) and the DST funding agency for approving and funding this study.

### References

1. The Haemophilia A Mutation, Structure, Test and

- Resource Site. Available from: <http://hadb.org.uk>. [Last accessed on 2012 Feb 15].
- Pavlova A, Brondke H, Müsebeck J, Pollmann H, Srivastava A, Oldenburg J. Molecular mechanisms underlying hemophilia A phenotype in seven females. *J Thromb Haemost* 2009;7:976-82.
  - Martín-Salces M, Venceslá A, Álvarez-Román MT, Rivas I, Fernandez I, Butta N, et al. Clinical and genetic findings in five female patients with haemophilia A: Identification of a novel missense mutation, p.Phe2127Ser. *Thromb Haemost* 2010;104:718-23.
  - Shetty S, Ghosh K, Mohanty D. Hemophilia B in a female. *Acta Haematol* 2001;106:115-7.
  - Venceslá A, Fuentes-Prior P, Baena M, Quintana M, Baiget M, Tizzano EF. Severe haemophilia A in a female resulting from an inherited gross deletion and a de novo codon deletion in the F8 gene. *Haemophilia* 2008;14:1094-8.
  - Cai XH, Wang XF, Dai J, Fang Y, Ding QL, Xie F, et al. Female hemophilia A heterozygous for a de novo frameshift and a novel missense mutation of factor VIII. *J Thromb Haemost* 2006;4:1969-74.
  - Jayandharan G, Shaji RV, Baidya S, Nair SC, Chandy M, Srivastava A. Identification of factor VIII gene mutation in 101 patients with haemophilia A: Mutation analysis by inversion screening and multiplex PCR and CSGE and molecular modeling of 10 novel missense substitutions. *Haemophilia* 2005;11:481-91.
  - Ganguly A. An update on conformation sensitive gel electrophoresis. *Hum Mutat* 2002;19:334-42.
  - Bicocchi MP, Pasino M, Lanza T, Bottini F, Boeri E, Mori PG. Analysis of 18 novel mutations in the factor VIII gene. *Br J Haematol* 2003;122:810-7.
  - Knobe KE, Sjörin E, Soller MJ, Liljebjörn H, Ljung RC. Female haemophilia A: Two unusual cases caused by skewed X inactivation. *Haemophilia* 2008;14:846-8.

**Cite this article as:** Nair PS, Shetty S, Ghosh K. A homozygous female hemophilia A. *Indian J Hum Genet* 2012;18:134-6.

**Source of Support:** Partial grant – The Lady Tata Memorial Trust, DST (Department of Science and Technology)., **Conflict of Interest:** None declared.