

Genetic and Epigenetic Analysis in Korean Patients with Multiple Endocrine Neoplasia Type 1

Yoon Jung Chung^{1,2}, Sena Hwang¹, Jong Ju Jeong³, Sun Yong Song¹, Se Hoon Kim⁴, Yumie Rhee^{1,2}

¹Department of Internal Medicine, Endocrine Research Institute, Severance Hospital, Yonsei University College of Medicine;

²Brain Korea 21 Project for Medical Science, Departments of ³Surgery, ⁴Pathology, Yonsei University College of Medicine, Seoul, Korea

Background: Multiple endocrine neoplasia type 1 (MEN1) is a familial syndrome characterized by the parathyroid, pancreas and pituitary tumors. Parathyroid tumors are the most common clinical manifestations, occurring in more than 90% of MEN1 patients. Heterozygous germline mutations of the *MEN1* gene underlie the tumorigenesis in MEN1 and epigenetic alterations along with germline mutations may contribute to tumorigenesis. Here, we investigated the associations between genotype and phenotype in Korean MEN1 patients.

Methods: We analyzed medical records from 14 unrelated MEN1 patients who had newly confirmed *MEN1* germline mutations, together with 14 previous reports in Korea. Aberrant DNA methylations were also examined in MEN1-related parathyroid tumors using the Infinium HumanMethylation 450 BeadChip.

Results: Total 28 germline mutations of *MEN1* were relatively highly concentrated in exons 7 and 8 compared to previous reports from Western countries. Six mutations (c.111dupT/p.S38Ffs*79, c.225_226insT/p.T76Yfs*41, c.383_398del16/p.S128Tfs*52, c.746dupT/p.H250Afs*20, c.1150G>T/p.E384*, and c.1508G>A/p.G503N) were newly found in the present study. Of interest, four patients (15%) showed unusual initial presentations and three patients were diagnosed incidentally at the general medical checkup. We also found three distinct sites in exon 2 of *MEN1* were significantly hypomethylated in the MEN1 parathyroid tumors, comparing correspondent blood samples.

Conclusion: We also have found a lack of genotype/phenotype correlation in Korean MEN1 patients. There were not a few unusual initial manifestations in MEN1 patients, thus, genetic testing for the *MEN1* germline mutations can provide important information for the better prognosis. Further studies are warranted to investigate altered DNA methylations in the *MEN1* gene involved in tumorigenesis.

Keywords: Germ-line mutation; DNA methylation; Multiple endocrine neoplasia type 1; Korea

INTRODUCTION

Multiple endocrine neoplasia type 1 (MEN1) is an autosomal dominant hereditary disorder characterized by the combined

occurrence of tumors of the parathyroid glands, pancreas and anterior pituitary gland [1-3]. In addition to these major lesions, adrenal gland tumors, facial angiofibroma, collagenoma, ependymoma, and thyroid lesions are also observed [2,3].

Received: 23 October 2013, **Revised:** 29 October 2013,

Accepted: 31 October 2013

Corresponding author: Yumie Rhee

Department of Internal Medicine, Yonsei University College of Medicine, 50-1 Yonsei-ro, Seodaemun-gu, Seoul 120-752, Korea

Tel: +82-2-2228-1973, **Fax:** +82-2-393-6884, **E-mail:** yumie@yuhs.ac

Copyright © 2014 Korean Endocrine Society

This is an Open Access article distributed under the terms of the Creative Commons Attribution Non-Commercial License (<http://creativecommons.org/licenses/by-nc/3.0/>) which permits unrestricted non-commercial use, distribution, and reproduction in any medium, provided the original work is properly cited.

The prevalence of hyperparathyroidism is more than 90% in MEN1 patients and that of pancreas tumors and pituitary tumors are 40% to 70% and 30% to 60%, respectively [3]. In Korean literature, since the first case of MEN1, diagnosed radiologically, was reported in 1986 [4], a total of 46 cases have been reported including the present study. Among total cases, 28 unrelated patients were confirmed by the germline mutations of the *MENIN* gene, but there is a scarcity of data delineating genotype-phenotype relationships in Korean patients.

MEN1 is caused by germline mutations of the *MENIN* tumor suppressor gene linked to the chromosomal locus 11q13 [5,6]. The gene consists of one untranslated and nine coding exons, encoding the 610 amino acid protein, menin [5]. More than 400 germline and somatic mutations in *MENIN* have been found throughout the whole coding sequences, and most of the mutations predict a premature protein truncation [2,5]. However, the absence of a mutational 'hot spot' and lack of genotype-phenotype correlations in MEN1 have been established so far [2,7,8]. This challenging finding might have been affected by additional genetic or epigenetic changes involved in tumorigenesis.

Growing evidence shows that abnormal DNA methylation, along with genetic alterations lead to altered patterns of gene expression in tumorigenesis [9]. DNA methylation plays an important role in silencing tissue-specific genes, imprinted genes, and repetitive elements [10]. Recently, comprehensive analysis of DNA methylation alterations in benign and malignant parathyroid tumors has been reported [9]. However, little is known about tissue specific methylation, especially regarding the *MENIN* gene in parathyroid tumors due to germline mutation of *MENIN*.

Therefore, we investigated the results of extensive genetic analysis of *MENIN* together with clinical phenotypes, and analyzed genotype/phenotype correlations in Korean MEN1 patients. Furthermore, we examined DNA methylation status in MEN1-related parathyroid tumors and compared those to patterns observed in corresponding peripheral blood.

METHODS

Patients

We first reviewed the medical records of 14 unrelated MEN1 patients who had germline mutations of the *MENIN* gene confirmed in Severance Hospital (Seoul, Korea). We evaluated the extended data from a total of 28 unrelated patients including 14 cases in the present study and 14 cases previously reported

with genetic confirmation in Korea by searching on PubMed and KoreaMed [11-21]. The clinical characteristics of six family members were collected for *MENIN* germline mutation carriers to analyze any relationship between genotypes and phenotypes. The diagnosis of MEN1 was based on the presence of at least two of three main MEN1-related endocrine tumors (parathyroid, pituitary, and pancreas neuroendocrine tumors). Familial MEN1 was defined as one MEN1 case and at least one first-degree relative with at least one of the three main MEN1-related tumors, as previously established [22]. Approval was obtained from the Institutional Review Board of Severance Hospital, Yonsei University College of Medicine in 2011 (4-2011-0613).

Germline mutation analysis of the *MENIN* gene

Genomic DNA was isolated from peripheral blood leukocytes using a QIAamp DNA Blood Mini Kit (QIAGEN GmbH, Hilden, Germany) according to the manufacturer's instructions. The nine exons of the *MENIN* gene as well as their flanking introns were amplified using primers. Polymerase chain reaction (PCR) was carried out using a thermal cycler (model 9700, Applied Biosystems, Foster City, CA, USA) as follows: 35 cycles of denaturation at 94°C for 30 seconds, annealing at 60°C for 30 seconds, and extension at 72°C for 1 minute. The amplicon was purified using Agencourt AMPure XP (Beckman Coulter Genomics, Danvers, MA, USA). Direct sequencing was performed using the BigDye Terminator Cycle Sequencing Ready Reaction kit on an ABI Prism 3130 genetic analyzer. All variants were confirmed based on the NCBI Single Nucleotide Polymorphism database (<http://www.ncbi.nlm.nih.gov/SNP>) and Human Gene Mutation Database database (<http://www.hgmd.org>).

DNA methylation profiling

We used MEN1-related parathyroid tumors to investigate DNA methylation profiling because we could only get the tumor tissues after parathyroidectomy. Six MEN1-related parathyroid tumors from the patients in Table 1 (cases 2-1, 8, 12, 19, 25, and 26) and five of their blood samples (cases 1, 2-1, 8, 12, and 25) were obtained, and consent was obtained from all participants in this study. The sodium bisulfite conversion was performed on 1 mg of genomic DNA for each sample with the EZ DNA kit (Zymo Research, Orange, CA, USA), and 200 ng of the converted DNA was used for PCR amplification. Amplified DNA was hybridized on the Infinium HumanMethylation 450 BeadChip (Illumina, San Diego, CA, USA) follow-

Table 1. Germline Mutations of the *MEN1N* Gene and Clinical Phenotypes in Korea

| Case no. | Sex/Age | FH | Exon | Codon | Mutation ^a | Effect | Pituitary tumor | Parathyroid tumor | Pancreas tumor | Other | Reference |
|----------|----------|----|------|---------|------------------------------|-------------------------|-----------------|----------------------------------|--------------------------------------|---|-----------|
| 1 | F/61 | - | 2 | 38 | c.111dupT ^b | fs | Prolactin+ | Adenoma | Neuroendocrine carcinoma Gastrin+ | Gastric neuroendocrine tumor | - |
| 2 | M/50 | + | 2 | 66-67 | c.196_200dupAGCCC | fs | - | - | Nonfunctioning | - | - |
| 2-1 | F/27 (D) | - | 2 | 66-67 | c.196_200dupAGCCC | fs | Prolactin+ | Adenoma | Nonfunctioning | Adrenal adenoma | - |
| 3 | M/48 | + | 2 | 66-67 | c.196_200dupAGCCC | fs | - | Hyperparathyroidism ^c | Nonfunctioning | Adrenal adenoma | - |
| 4 | F/46 | - | 2 | 66-67 | c.196-200dupAGCCC | fs | Nonfunctioning | Adenoma | Calcitonin+ | Papillary thyroid cancer Breast cancer Thymic carcinoid tumor Adrenal adenoma | [12] |
| 5 | F/22 | - | 2 | 67 | c.200 - 201insAGCCC | fs | Prolactin+ | Adenoma | Insulin+ | - | [13] |
| 6 | M/52 | + | 2 | 67 | c.200 - 201insAGCCC | fs | - | Adenoma | Nonfunctioning | Empty sella Adrenal adenoma | [14] |
| 7 | Unknown | - | 2 | 67 | c.200 - 201insAGCCC | fs | Nonfunctioning | Hyperparathyroidism ^c | Nonfunctioning | - | [15] |
| 8 | M/39 | + | 2 | 76 | c.225_226insT ^b | fs | Acromegaly | Adenoma | Nonfunctioning | Cushing syndrome, adrenal Spinal cord ependymoma | - |
| 9 | F/23 | + | 2 | 84-85 | c.252_255delTATC | fs | Nonfunctioning | Adenoma | Insulin+ | Spinal cord tumor, schwannoma | [16] |
| 10 | F/45 | + | 2 | 126 | c.378G>A | ns, p.W126 ^d | Prolactin+ | Adenoma | Nonfunctioning | - | - |
| 11 | F/43 | + | 2 | 128 | c.383_398del116 ^b | fs | Nonfunctioning | Hyperplasia | Insulin+ | Rib chondrosarcoma Papillary thyroid cancer Adrenal adenoma | - |
| 11-1 | F/24 (D) | - | 2 | 128 | c.383_398del116 ^b | fs | Nonfunctioning | Hyperparathyroidism ^c | - | - | - |
| 12 | F/59 | - | 3 | 164 | c.491C>A | ms, p.A164D | - | Adenoma | Nonfunctioning | Empty sella | - |
| 13 | M/39 | - | 3 | 210-211 | c.628_631delACAG | fs | - | Adenoma | Neuroendocrine carcinoma | Stomach carcinoid tumor | - |
| 14 | F/26 | + | 3 | 210-211 | c.628_631delACAG | fs | Prolactin+ | Hyperplasia | Insulin+ | - | [17] |
| 15 | M/51 | - | 3 | 215 | c.643G>A | ms, p.V215M | Prolactin+ | Hyperplasia | Nonfunctioning | Papillary thyroid cancer, Thymic carcinoid tumor | [18] |
| 16 | F/34 | - | 4 | 250 | c.746dupT ^b | fs | Prolactin+ | Adenoma | Insulin+ | - | - |
| 17 | Unknown | - | 7 | 323 | c.969C>A ^b | ns, p.Y323 ^d | Prolactin+ | Hyperparathyroidism ^c | Insulin+ | - | [15] |
| 18 | Unknown | + | 7 | 325 | c.973G>C ^b | ms, p.A325P | Prolactin+ | Hyperparathyroidism ^c | Insulin+, Glucagon+ | - | [15] |
| 19 | F/81 | + | 7 | 350 | c.1049A>T ^{b,c} | ms, p.D350V | - | Adenoma | Nonfunctioning | - | [11] |
| 19-1 | F/50 (D) | - | 7 | 350 | c.1049A>T ^b | ms, p.D350V | Prolactin+ | Adenoma | Nonfunctioning | Leiomyoma in the bladder, the Uterus, and the esophagus Adrenal adenoma R/O liver neuroendocrine tumor | [11] |
| 20 | F/55 | + | 8 | 384 | c.1150G>T ^b | ns, p.E384d | Nonfunctioning | Adenoma | Neuroendocrine carcinoma | - | - |
| 20-1 | F/29 (D) | - | 8 | 384 | c.1150G>T ^b | ns, p.E384d | - | Adenoma | - | Rathke's cleft cyst Lipoma | - |

(Continued to the next page)

Table 1. Continued

| Case no. | Sex/Age | FH | Exon | Codon | Mutationa | Effect | Pituitary tumor | Parathyroid tumor | Pancreas tumor | Other | Reference |
|----------|----------|----|-------|------------------|------------------------|-------------------------|-----------------|-------------------|--------------------------|---|-----------|
| 20 | F/55 | + | 8 | 384 | c.1150G>T ^b | ns, p.E384 ^d | Nonfunctioning | Adenoma | Neuroendocrine carcinoma | | - |
| 20-1 | F/29 (D) | | 8 | 384 | c.1150G>T ^b | ns, p.E384 ^d | | Adenoma | - | Rathke's cleft cyst Lipoma | - |
| 21 | Unknown | + | 9 | 405 | c.1213C>T ^b | ns, p.Q405 ^d | Prolactin+ | - | Somatostatin+ | | [15] |
| 22 | F/48 | - | 9 | 415 | c.1243C>T | ns, p.R415 ^d | Prolactin+ | Hyperplasia | Neuroendocrine carcinoma | Adrenal adenoma Gallbladder carcinoid tumor | [20] |
| 23 | M/70 | - | 9 | 418 ^c | c.1252G>C ^b | ms, p.D418H | - | Adenoma | VIP+ | | [21] |
| 24 | F/51 | - | 9 | 418 | c.1252G>A | ms, p.D418N | Nonfunctioning | Adenoma | Gastrin+ | Lipoma | - |
| 25 | F/39 | + | int 9 | | c.1350+2T>G | sp | Nonfunctioning | Hyperplasia | Nonfunctioning | Liver hemangioma and cyst | - |
| 25-1 | F/38 (S) | | int 9 | | c.1350+2T>G | sp | Nonfunctioning | Adenoma | - | Gallbladder polyps | - |
| 26 | M/48 | - | 10 | 503 | c.1508G>A ^b | ms, p.G503N | | Hyperplasia | - | Rathke's remnant Gallbladder adenomyomatosis | - |
| 27 | M/66 | + | 10 | 517 | c.1548_1549insG | fs | - | Adenoma | Gastrin+ | | - |
| 27-1 | F/32 (D) | | 10 | 517 | c.1548_1549insG | fs | Prolactin+ | Adenoma | Gastrin+ | | - |
| 28 | M/51 | - | 10 | 527 | c.1579C>T | ns, p.R527 ^d | - | Adenoma | Nonfunctioning | Pulmonary neuroendocrine tumor | [19] |

FH, family history; F, female; fs, frameshift mutation; D, daughter; M, male; ns, nonsense mutation; ms, missense mutation; VIP, VIPoma; int, intron; sp, splice site mutation; S, sister.
^aMutations are numbered in relation to the *MEN1* cDNA reference sequence (GenBank accession number NM_130799.1); ^bNovel mutation in the present study or previous reports in Korea; ^cClinical diagnosis of hyperparathyroidism; ^dStop codon; ^eDiscordant codon/nucleotide number in the original report.

ing the standard protocols. The hybridized images were processed and intensity data was then extracted after scanning using an Illumina HiScan SQ scanner. β Values ranging from 0 to 1 were calculated for the DNA methylation profile of each candidate. Finally, the candidates were ranked and selected base on the delta-beta (difference between β values) using the Illumina's GenomeStudio Methylation Module, as previously reported [23].

RESULTS

Germline mutations of the *MEN1* gene in Korea

In the present study, we identified 14 germline mutations of the *MEN1* gene in seven familial and seven sporadic MEN1 patients by direct sequencing. Herein, we extensively collected germline mutations of the *MEN1* gene in Korean MEN1 patients from previous reports. There were 28 germline mutations in total 34 members of 14 familial (50%) and 14 sporadic cases (50%) (Table 1), and the distribution is shown in Fig. 1. Majority of the mutations were concentrated in exon 2 (11/28, 39%), 9 (4/28, 14%), and exon 10 (3/28, 11%) which are nine known sites of higher frequency previously classified as I to IX, but unexpected higher frequency in the excluded sites of exons 7 and 8 (14%) were also found in our cases (Fig. 1) [3]. Most of the mutations resulted in frameshift changes which were found in 14 unrelated patients (50%), and five nonsense mutations (18%), eight missense mutations (29%), and one splice site mutation (3%) were documented (Fig. 2). In-frame deletion/insertion mutation or large deletion was not found in this study. Six mutations (c.111dupT/p.S38Ffs*79, c.225_226insT/p.T76Yfs*41, c.383_398del16/p.S128Tfs*52, c.746dupT/p.H250Afs*20, c.1150G>T/p.E384*, and c.1508G>A/p.G503N) were newly confirmed as novel in the present study and the four (c.969C>A/p.Y323*, c.973G>C/p.A325P, c.1213C>T/p.Q405*, and c.1049A>T/p.D350V) have been previously described as novel in Korea (Table 1, Fig. 1).

Clinical phenotypes of MEN1 in Korea

The phenotypic expression of MEN1 in all 34 cases is summarized in Table 1. The most common manifestations were parathyroid tumors (94%, 32/34), pancreas tumors (88%, 30/34), and pituitary tumors (68%, 23/34). Less common MEN1-related tumors were documented in 62% of the patients (21/34): seven adrenal adenomas, six carcinoid tumors (in the stomach, thymus, liver, and lung), two lipomas, and two spinal cord tumors (ependymoma and schwannoma). Finally, 21 patients

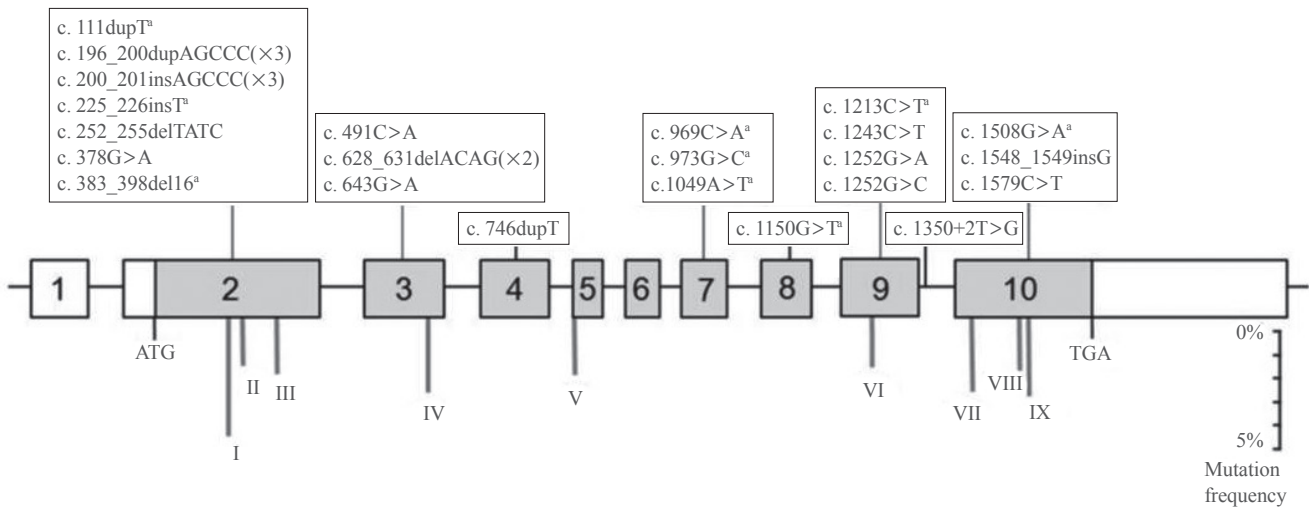

Fig. 1. Summary data of germline mutations of *MEN1* in 28 unrelated patients with multiple endocrine neoplasia type 1 in Korea. The positions of the mutations in *MEN1* are illustrated above respective exons. ATG refers to the start codon; TGA refers to the stop codon. ^aMutations were reported as novel in Korea including the present study. Germline mutations (I to IX) that occur with a frequency >1.5% are shown and their respective frequencies (scale shown on the right lower) in the review are indicated by the vertical lines at lower part of the gene [3]. These germline mutations, which collectively represent 20.6% of all reported germline mutations, are: I, c.249_252delGTCT (4.5%); II, c.292C>T (1.5%); III, c.358_360delAAG (1.7%); IV, c.628_631delACAG (2.5%); V, c.784-9G>A (1.9%); VI, c.1243C>T (1.5%); VII, c.1378C>T (2.6%); VIII, c.1546delC (1.8%); IX, c.1546_1547insC (2.7%).

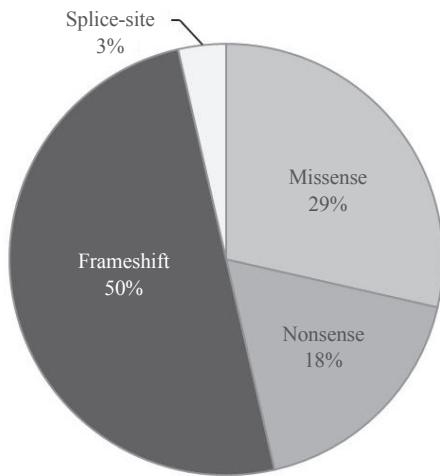

Fig. 2. Frequencies of the types of *MEN1* mutations detected in 28 unrelated patients with multiple endocrine neoplasia type 1. In-frame deletion/insertion was not detected. Gross deletion was not confirmed.

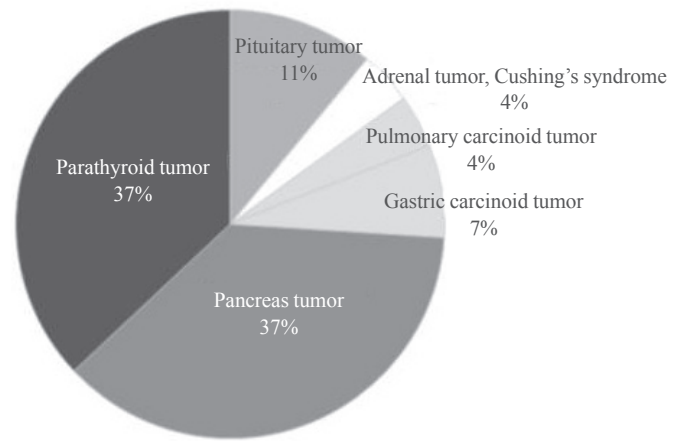

Fig. 3. First manifestations of multiple endocrine neoplasia type 1 (*MEN1*) in Korea. Among 27 symptomatic patients, hyperparathyroidism was documented in 10 patients (37%), pancreas tumors in 10 (37%), and pituitary tumors in three (11%). Four patients (15%) showed less common tumors associated with *MEN1* as a first manifestation.

(62%) had combined tumor involvement of all three main target endocrine glands; 26% (9/34) presented with tumors of the two glands; and 12% (4/34) with one gland.

The first clinical manifestations were available in 30 cases and their mean age was 45 years (median age, 46; range, 21 to 81) (Fig. 3). Three of them (cases 3, 6, and 23 in Table 1) were asymptomatic and incidentally diagnosed at a general health

checkup. Two of these cases (cases 3 and 6) had incidentally detected concurrent pancreas and adrenal tumors at the medical checkup. Among 27 symptomatic patients, hyperparathyroidism or hypercalcemia were the first clinical manifestations of *MEN1* in 10 patients (median age, 46 years; range 29 to 81

years), pancreas tumors in 10 (median age, 36 years; range 21 to 70 years), and pituitary tumors in three patients (median age, 26 years; range 24 to 34 years) (Fig. 3). Four patients (median age, 44 years; range 27 to 57 years) showed less common tumors associated with MEN1 as a first manifestation, including carcinoid tumors in the stomach or lung and the ad-

renal cortical adenoma associated with Cushing syndrome (Fig. 3).

Defining the relationship between the germline mutations of *MENIN* and the associated with clinical manifestations of MEN1, we could not find any direct genotype-phenotype correlations in this study, as already shown by other studies.

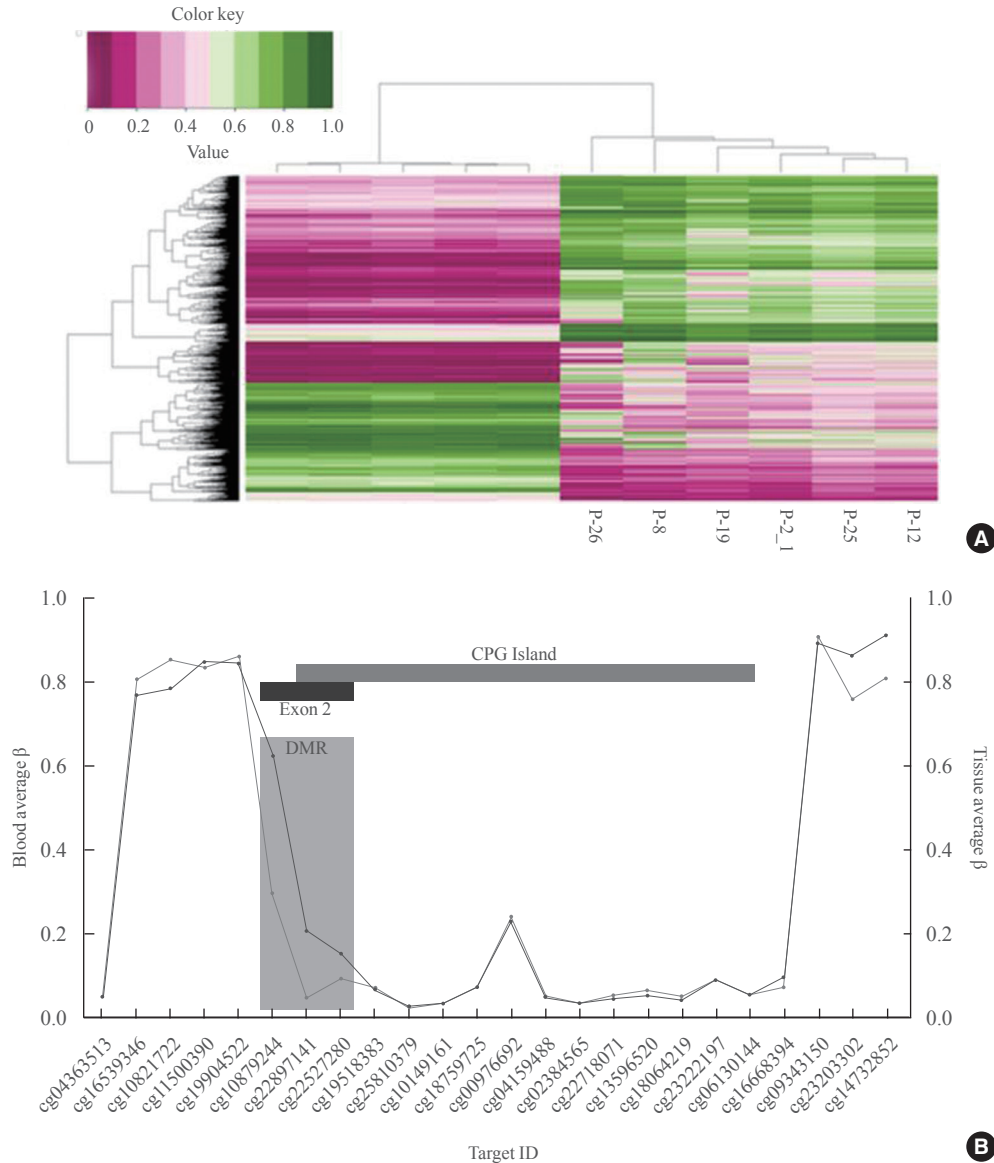

Fig. 4. Distinct methylation pattern of hereditary parathyroid tumors compared to respective blood controls (A) and methylation profile of the *MENIN* gene (B). (A) Heatmap of all differentially methylated genes showing distinct methylation patterns of multiple endocrine neoplasia type 1 (MEN1)-related parathyroid tumors. Heatmap color corresponds to the β -value of the measured CpG-sites. β Ranges from 0 (purely unmethylated, shown in pink) to 1 (purely methylated, shown in green). (B) In this line plot blood average β is indicated by a black line and the parathyroid tissue average β is indicated by a grey line. Significant methylation differences are confined to exon 2 of the *MENIN* gene: three hypomethylation sites (cg10879244, cg22897141, and cg22527280) are described in the grey box with black arrows. The samples for heatmap are indicated according to specimen (B=blood sample and P=parathyroid tumor); digits after the hyphen denote case numbers as shown in Table 1. DMR, differentially methylated regions.

DNA methylation profiling in parathyroid tumors

We examined DNA methylation status in MEN1-related parathyroid tumors comparing to those corresponding to the patterns observed in peripheral blood using the Infinium Human-Methylation 450 BeadChip. Distinct hierarchical clustering of genes with altered DNA methylation profiles in blood controls and MEN1 parathyroid tumors was evident (Fig. 4A). The 5' region of *MENIN* contains a high proportion of "CpG islands." Among these dinucleotides, three sites were significantly hypomethylated in the exon 2 of *MENIN*: chr11, position 64,577,190 (cg10879244, $\beta = -0.329$, $P < 0.001$), 64,577,338 (cg22897141, $\beta = -0.163$, $P = 0.001$), and 64,577,427 (cg22527280, $\beta = -0.063$, $P < 0.001$) (Fig. 4B).

DISCUSSION

The screening for germline mutations of the *MENIN* gene makes it possible to perform early diagnosis and better clinical management for mutation carriers. Unfortunately, few studies to date have done genetic testing for MEN1 in Korea; a total of 28 germline mutations (14 familial and 14 sporadic mutations) have been characterized in Korean MEN1 patients. The majority (71%) of the mutations were inactivating ones that would result from the frameshift, nonsense, and splice site mutations that are consistent with previous reports [2,24,25]. We could not find in-frame deletion/insertion mutations in this work, indicating low frequency of this mutation in Korean MEN1; similar to findings in other populations [2].

Parathyroid tumors are often the first manifestation of MEN1 in more than 85% of patients [26,27]. Meanwhile, hyperparathyroidism by the parathyroid tumor, and pancreas tumors were less common presentations in this study; each appearing in 37% of the patients. On the other hand, 15% of the patients showed unusual initial manifestation of MEN1 (Fig. 3). We identified one case (case 8 in Table 1) with Cushing syndrome due to adrenal cortical adenoma as a first presentation of the disorder. The patient also had spinal cord ependymoma which less commonly develops in MEN1 patients. The prevalence of adrenal lesions in patients with MEN1 varies from 36% to 73% and most of them are nonfunctional [28,29]. Cushing syndrome due to adrenal cortical adenomas as a MEN1-related lesion is very rare, and has been documented in only three cases reported worldwide including this case [30,31]. The other two cases had nonsense mutations (c.781C>T) in the exon 4 [30] or splicing mutation (c.912+1G>A, IVS6+1G>A) in the intron 6 [31]. These mutations would lead to a disruption and loss of

function of *MENIN*.

Four cases (4/35, 11%) had been diagnosed with papillary thyroid cancer concurrently with MEN1-related tumors. Thyroid disease is known to be detected incidentally in over 25% of MEN1 patients [32,33]. Normal thyroid glands have been shown to express menin [34], thus, thyroid tumors in MEN1 patients possibly involved with the *MENIN* mutations. Genetic analysis of less common tumors such as carcinoids, lipomas, angiofibromas, and esophageal and uterine leiomyomas have reported a loss of heterozygosity (LOH), indicating a role for *MENIN* mutation in the etiology of these tumors as predicted by the two-hit model of Knudson [35,36]. But no evidence of LOH in the papillary thyroid cancer in MEN1 was reported in two cases [32,36]; thus, it seems that loss of the tumor suppressor function of menin is not required for the tumor formation in these cases. However, in this study, papillary thyroid cancer was the most common manifestation together with adrenal adenoma next to the main three lesions in MEN1 patients. Thus, other genetic alterations without obvious LOH of the gene locus should have occurred.

As we expected, correlations between *MENIN* mutations and clinical manifestations also appear to be absent in this study. Regarding the two frameshift mutations, c.196_200dupAGCCC and c.200_201insAGCCC (exon 2), each occurred three times, and one, c.628_631delACAG, occurred twice in the different unrelated patients. Even in the patients with same mutations and individual members of the same family, a wide range of MEN1-associated tumors and a lack of genotype/phenotype correlations were revealed. This finding may suggest various clinical manifestations may be caused by tissue-specific modulations such as epigenetic factors. Therefore, we attempted to find epigenetic changes using a methylation study in MEN1-related parathyroid tumors.

In the context of the Knudson two-hit hypothesis, up to 80% of MEN1-associated tumors exhibited LOH of 11q13 [37]. Even though the LOH of parathyroid tumors was not confirmed in this study, we attempted to determine DNA methylation profiles in MEN1-related parathyroid tumors and compare these to respective blood samples. There was altered DNA methylation in the *MENIN* gene of MEN1-related parathyroid tumors. DNA methylation of the first exon is associated with tissue-specific regulation of gene expression [38]. Although we were not able to determine the role of the three hypomethylations in the *MENIN* gene identified in this study, these modifications possibly play a role in the parathyroid tumorigenesis and future studies are warranted.

To summarize the status of Korean MEN1: (1) there were relatively high frequency of the mutations in exons 7 and 8 of the *MEN1* gene; (2) unusual initial manifestations of MEN1 were present in a quite a few MEN1 patients in Korea; thus, genetic testing can provide important information for clearer diagnosis; and (3) the analysis for epigenetic factors regarding tumorigenesis should be considered more carefully.

CONFLICTS OF INTEREST

No potential conflict of interest relevant to this article was reported.

ACKNOWLEDGMENTS

This research was supported by a grant from the Yonsei University College of Medicine (6-2011-0104).

REFERENCES

- Hoff AO, Cote GJ, Gagel RF. Multiple endocrine neoplasias. *Annu Rev Physiol* 2000;62:377-411.
- Lemos MC, Thakker RV. Multiple endocrine neoplasia type 1 (MEN1): analysis of 1336 mutations reported in the first decade following identification of the gene. *Hum Mutat* 2008;29:22-32.
- Thakker RV. Multiple endocrine neoplasia type 1 (MEN1). *Best Pract Res Clin Endocrinol Metab* 2010;24:355-70.
- Oh KY, Lee NS, Jang DS, You KH, Baek HS. Multiple endocrine neoplasm type I: a case report. *Korean J Med* 1986; 31:229-35.
- Chandrasekharappa SC, Guru SC, Manickam P, Olufemi SE, Collins FS, Emmert-Buck MR, Debelenko LV, Zhuang Z, Lubensky IA, Liotta LA, Crabtree JS, Wang Y, Roe BA, Weisemann J, Boguski MS, Agarwal SK, Kester MB, Kim YS, Heppner C, Dong Q, Spiegel AM, Burns AL, Marx SJ. Positional cloning of the gene for multiple endocrine neoplasia-type 1. *Science* 1997;276:404-7.
- Guru SC, Manickam P, Crabtree JS, Olufemi SE, Agarwal SK, Debelenko LV. Identification and characterization of the multiple endocrine neoplasia type 1 (MEN1) gene. *J Intern Med* 1998;243:433-9.
- Wautot V, Vercherat C, Lespinasse J, Chambe B, Lenoir GM, Zhang CX, Porchet N, Cordier M, Beroud C, Calender A. Germline mutation profile of MEN1 in multiple endocrine neoplasia type 1: search for correlation between phenotype and the functional domains of the MEN1 protein. *Hum Mutat* 2002;20:35-47.
- Kouvaraki MA, Lee JE, Shapiro SE, Gagel RF, Sherman SI, Sellin RV, Cote GJ, Evans DB. Genotype-phenotype analysis in multiple endocrine neoplasia type 1. *Arch Surg* 2002;137:641-7.
- Starker LF, Svedlund J, Udelsman R, Dralle H, Akerstrom G, Westin G, Lifton RP, Bjorklund P, Carling T. The DNA methylome of benign and malignant parathyroid tumors. *Genes Chromosomes Cancer* 2011;50:735-45.
- Zhang M, Xu C, von Wettstein D, Liu B. Tissue-specific differences in cytosine methylation and their association with differential gene expression in sorghum. *Plant Physiol* 2011;156:1955-66.
- Choi H, Kim S, Moon JH, Lee YH, Rhee Y, Kang ES, Ahn CW, Cha BS, Lee EJ, Kim KR, Lee HC, Jeong SY, Kim HJ, Lim SK. Multiple endocrine neoplasia type 1 with multiple leiomyomas linked to a novel mutation in the MEN1 gene. *Yonsei Med J* 2008;49:655-61.
- Choi JH, Kim HI, Kang SM, Kim SG, Oh HK, Bae SH, Ryoo HM. A case of a calcitonin-secreting pancreatic endocrine tumor in a patient with multiple endocrine neoplasia type 1. *Korean J Med* 2012;83:817-22.
- Park SE, Kang ES, Lee HJ, Kim SH, Do MY, Kang SA, Han SJ, Kim HJ, Ahn CW, Cha BS, Lim SK, Kim KR, Kim IJ, Lee HC. A case of multiple endocrine neoplasia type 1 with mutation in MEN1 gene. *J Korean Soc Endocrinol* 2005;20:71-7.
- Sung HY, Chun YJ, Lee H, Kwon BJ, Park KW, Lee JM, Moon SD, Chang SA, Han JH. A case of familial multiple endocrine neoplasia with MEN1 gene mutation. *J Korean Endocr Soc* 2006;21:560-6.
- Park JH, Kim IJ, Kang HC, Lee SH, Shin Y, Kim KH, Lim SB, Kang SB, Lee K, Kim SY, Lee MS, Lee MK, Park JH, Moon SD, Park JG. Germline mutations of the MEN1 gene in Korean families with multiple endocrine neoplasia type 1 (MEN1) or MEN1-related disorders. *Clin Genet* 2003; 64:48-53.
- Kim MJ, Kim EH, Shin MS, Kim JH, Na HK, Park SJ, Lee SA, Koh EH, Lee WJ, Song KH, Park JY, Lee KU, Kim GH, Yoo HW, Kim MS. A case of familial multiple endocrine neoplasia type 1 with a novel mutation in the MEN1 gene. *Endocrinol Metab* 2011;26:171-6.
- Jo YE, Choi YJ, Kim YK, Ahn SM, Jung SH, Kim HJ, Kim DJ, Lee KW, Hong JH, Jeong SY, Kim HJ, Chung YS. A case of familial multiple endocrine neoplasia type 1

- with MEN1 gene mutation. *J Korean Endocr Soc* 2007;22:68-73.
18. Choi YS, Bai YS, Ku BJ, Jo YS, Kim YK, Ro HK, Shong M. A case of multiple endocrine neoplasia type I with atypical clinical course. *J Korean Endocr Soc* 2008;23:266-71.
 19. Sim YS, Lee JH, Moon JW, Oh JY, Kim YK, Sung SH, Chang JH. A case of multiple endocrine neoplasia type I with pulmonary large cell neuroendocrine carcinoma. *Korean J Med* 2007;72(Suppl 2):S214-20.
 20. Cho PS, Park H, Lee GH, Lee MC. A case of asymptomatic multiple endocrine neoplasia type 1 detected incidentally on health screening. *Korean J Otorhinolaryngol-Head Neck Surg* 2012;55:373-7.
 21. Lee SW, Choi YS, Park YH, Oh KS, Shin JW, Kim IJ, Uchino S. A case of multiple endocrine neoplasia associated with VIPoma. *J Korean Soc Endocrinol* 2005;20:64-70.
 22. Brandi ML, Gagel RF, Angeli A, Bilezikian JP, Beck-Peccoz P, Bordi C, Conte-Devolx B, Falchetti A, Gheri RG, Libroia A, Lips CJ, Lombardi G, Mannelli M, Pacini F, Ponder BA, Raue F, Skogseid B, Tamburrano G, Thakker RV, Thompson NW, Tomassetti P, Tonelli F, Wells SA Jr, Marx SJ. Guidelines for diagnosis and therapy of MEN type 1 and type 2. *J Clin Endocrinol Metab* 2001;86:5658-71.
 23. Kim M, Park YK, Kang TW, Lee SH, Rhee YH, Park JL, Kim HJ, Lee D, Lee D, Kim SY, Kim YS. Dynamic changes in DNA methylation and hydroxymethylation when hES cells undergo differentiation toward a neuronal lineage. *Hum Mol Genet* 2014;23:657-67.
 24. Jiang XH, Lu JL, Cui B, Zhao YJ, Wang WQ, Liu JM, Fang WQ, Cao YN, Ge Y, Zhang CX, Casse H, Li XY, Ning G. MEN1 mutation analysis in Chinese patients with multiple endocrine neoplasia type 1. *Endocr Relat Cancer* 2007;14:1073-9.
 25. Balogh K, Hunyady L, Patocs A, Gergics P, Valkusz Z, Toth M, Racz K. MEN1 gene mutations in Hungarian patients with multiple endocrine neoplasia type 1. *Clin Endocrinol (Oxf)* 2007;67:727-34.
 26. Pieterman CR, van Hulsteijn LT, den Heijer M, van der Luijt RB, Bonenkamp JJ, Hermus AR, Borel Rinkes IH, Vriens MR, Valk GD; DutchMEN1 Study Group. Primary hyperparathyroidism in MEN1 patients: a cohort study with longterm follow-up on preferred surgical procedure and the relation with genotype. *Ann Surg* 2012;255:1171-8.
 27. Eller-Vainicher C, Chiodini I, Battista C, Viti R, Mascia ML, Massironi S, Peracchi M, D'Agruma L, Minisola S, Corbetta S, Cole DE, Spada A, Scillitani A. Sporadic and MEN1-related primary hyperparathyroidism: differences in clinical expression and severity. *J Bone Miner Res* 2009;24:1404-10.
 28. Schaefer S, Shipotko M, Meyer S, Ivan D, Klose KJ, Waldmann J, Langer P, Kann PH. Natural course of small adrenal lesions in multiple endocrine neoplasia type 1: an endoscopic ultrasound imaging study. *Eur J Endocrinol* 2008;158:699-704.
 29. Skogseid B, Larsson C, Lindgren PG, Kvanta E, Rastad J, Theodorsson E, Wide L, Wilander E, Oberg K. Clinical and genetic features of adrenocortical lesions in multiple endocrine neoplasia type 1. *J Clin Endocrinol Metab* 1992;75:76-81.
 30. Vithian K, Shaafi K, Russell S. Multiple endocrine neoplasia type 1 and adrenal Cushing's. *JRSM Short Rep* 2011;2:10.
 31. Alzahrani AS, Al-Khaldi N, Shi Y, Al-Rijjal RA, Zou M, Baitei EY, Amin T. Diagnosis by serendipity: Cushing syndrome attributable to cortisol-producing adrenal adenoma as the initial manifestation of multiple endocrine neoplasia type 1 due to a rare splicing site MEN1 gene mutation. *Endocr Pract* 2008;14:595-602.
 32. Desai D, McPherson LA, Higgins JP, Weigel RJ. Genetic analysis of a papillary thyroid carcinoma in a patient with MEN1. *Ann Surg Oncol* 2001;8:342-6.
 33. Dong Q, Debelenko LV, Chandrasekharappa SC, Emmert-Buck MR, Zhuang Z, Guru SC, Manickam P, Skarulis M, Lubensky IA, Liotta LA, Collins FS, Marx SJ, Spiegel AM. Loss of heterozygosity at 11q13: analysis of pituitary tumors, lung carcinoids, lipomas, and other uncommon tumors in subjects with familial multiple endocrine neoplasia type 1. *J Clin Endocrinol Metab* 1997;82:1416-20.
 34. Wautot V, Khodaei S, Frappart L, Buisson N, Baro E, Lenoir GM, Calender A, Zhang CX, Weber G. Expression analysis of endogenous menin, the product of the multiple endocrine neoplasia type 1 gene, in cell lines and human tissues. *Int J Cancer* 2000;85:877-81.
 35. McKeeby JL, Li X, Zhuang Z, Vortmeyer AO, Huang S, Pirner M, Skarulis MC, James-Newton L, Marx SJ, Lubensky IA. Multiple leiomyomas of the esophagus, lung, and uterus in multiple endocrine neoplasia type 1. *Am J Pathol* 2001;159:1121-7.
 36. Vortmeyer AO, Lubensky IA, Skarulis M, Li G, Moon YW, Park WS, Weil R, Barlow C, Spiegel AM, Marx SJ, Zhuang Z. Multiple endocrine neoplasia type 1: atypical

- presentation, clinical course, and genetic analysis of multiple tumors. *Mod Pathol* 1999;12:919-24.
37. Pannett AA, Thakker RV. Somatic mutations in MEN type 1 tumors, consistent with the Knudson “two-hit” hypothesis. *J Clin Endocrinol Metab* 2001;86:4371-4.
38. Brenet F, Moh M, Funk P, Feierstein E, Viale AJ, Socci ND, Scandura JM. DNA methylation of the first exon is tightly linked to transcriptional silencing. *PLoS One* 2011; 6:e14524.