

doi: 10.5455/aim.2014.22.389-392

ACTA INFORM MED. 2014 DEC 22(6): 389-392

Received: 05 September 2014 • Accepted: 02 December 2014

© AVICENA 2014

Published online: 19/12/2014

Published print: 12/2014

ORIGINAL PAPER

Real Time Processing and Transferring ECG Signal by a Mobile Phone

Mahsa Raeiatibanadkooki¹, Saeed Rahati Quachani², Mohammadmahdi Khalilzade³, Kambiz Bahaadinbeigy⁴

Biomedical engineering, Islamic Azad University of Mashhad, Iran¹

Islamic Azad University of Mashhad, Iran²

Islamic Azad University of Mashhad, Iran³

Kerman University of Medical Sciences, Kerman, Iran⁴

Corresponding author: Mahsa Raeiatibanadkooki, M.S.c. Biomedical engineering department, Islamic Azad University Mashhad, Iran E-mail: mahsa.raeiati.b@gmail.com

ABSTRACT

The real-time ECG signal processing system based on mobile phones is very effective in identifying continuous ambulatory patients. It could monitor cardiovascular patients in their daily life and warns them in case of cardiac arrhythmia. An ECG signal of a patient is processed by a mobile phone with this proposed algorithm. An IIR low-pass filter is used to remove the noise and it has the 55 Hz cutoff frequency and order 3. The obtained SNR showed a desirable noise removal and it helps physicians in their diagnosis. In this paper, Hilbert transform was used and the R peaks are important component to differ normal beats from abnormal ones. The results of sensitivity and positive predictivity of algorithm are 96.97% and 95.63% respectively. If an arrhythmia occurred, 4 seconds of this signal is displayed on the mobile phone then it will be sent to a remote medical center by TCP/IP protocol.

Key words: ECG signal, Hilbert transform, IIR filter, m_health, TCP/IP protocol.

1. INTRODUCTION

ECG signals depend on the ionic currents that cause the heart muscle to contract and expand. In ECG signal the potential difference between the electrodes placed on the body surface are considered as input. Statistics show that approximately a 20-50% difference exists between primary interpretation of ECG signal and interpretation of a cardiologist[1]. ECG signals are important physiological signals for patients with cardiovascular diseases.

Recently, heart diseases are increasing at a phenomenal rate. According to the world health organization (WHO), cardiovascular diseases are a major cause of death in developing countries[2]. For this reason, monitoring and diagnosis of heart diseases are very important. Recording of ECG signal is a basic method for detecting heart diseases like arrhythmias and ischemic. Development of telemedicine in patient care systems plays an important role in signal processing. In the simplest form, cardiac signal has been transmitted between the telephone lines[3].

Due to the development of new technologies, ECG signal recording systems have a small size and low weight. The researchers were able to design a light weight system, with low power consumption and low cost by recent advances in networking technologies and wearable sensors, integrated circuits and wireless communications. Smart mobile phones have different applications from a medical point of view. The new generation of mobile phones have had a significant impact on the development of the health care system such as integrating a wide range of networks and thus creating opportunities for transferring medical records to the hospital[4].

The main aim of this paper is monitoring of the ECG sig-

nals and detecting heart diseases. It is suitable for continuous ECG transmission in telemedicine applications over a wireless network. This paper is organized as follows. The detailed explanation about the pre-processing and signal transmission are presented in Section II. The evaluation results and discussion are reported in section III. Finally, conclusions are made in Section IV.

2. MATERIALS AND METHODS

This paper includes the design and implementation of a health care program for the care of heart patients by mobile phones. The main goal is designing a software program for mobile ECG signal processing. ECG signals are recorded and then it is sent via bluetooth to the mobile phone. Generally, the ECG signal is polluted with noise. The ECG signal must be processed to extract useful information. In this paper, detection of QRS complexes provides important information about heart rate. The noises of the signals are removed by the mobile and on the basis of processing methods, a normal signal is distinguish form an abnormal signal. The abnormal signal is sent to a remote medical center via TCP/IP protocol for diagnosis and determining the type of arrhythmia.

2.1. ECG signal

In a normal ECG signal, correct arterial depolarization / repolarization and ventricular depolarization / repolarization can be seen during each cycle of ECG signal. In figure 1, P, Q, R, S, T waves and PQ, QRS, ST segments are shown. QRS complex is the most important part of the ECG signal. Reverse of RR interval is a pathological parameter in ECG signal and heart beat can be calculated at the moment. Heart

rate is an important clinical sign for assessing the patient's health status.

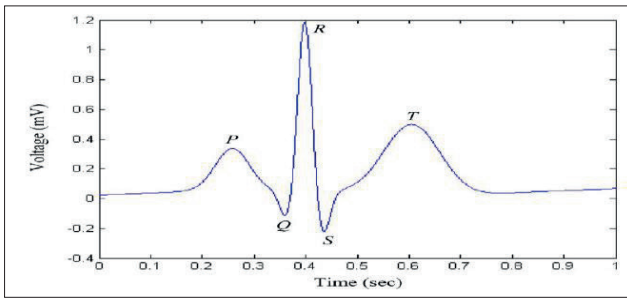

Figure 1. Display of ECG Signal

2.2. Database

In this paper, we used 2 type of data from MIT-BIH arrhythmia database, the first database has 48 records. Each record is 30 minutes length with 360 Hz sampling frequency. Each record consists of the upper and lower leads. Since normal QRS complexes might be usually prominent in the upper lead, the upper lead was used. The second database has 25 long-term ECG recordings of human subjects with atrial fibrillation with 250 Hz sampling frequency[5].

In previous researches, it has been hinted that Gaussian noise is added during transferring the ECG signal[1]. In order to access the best algorithm, gaussian noise is added to the data, then the proposed algorithm is tested.

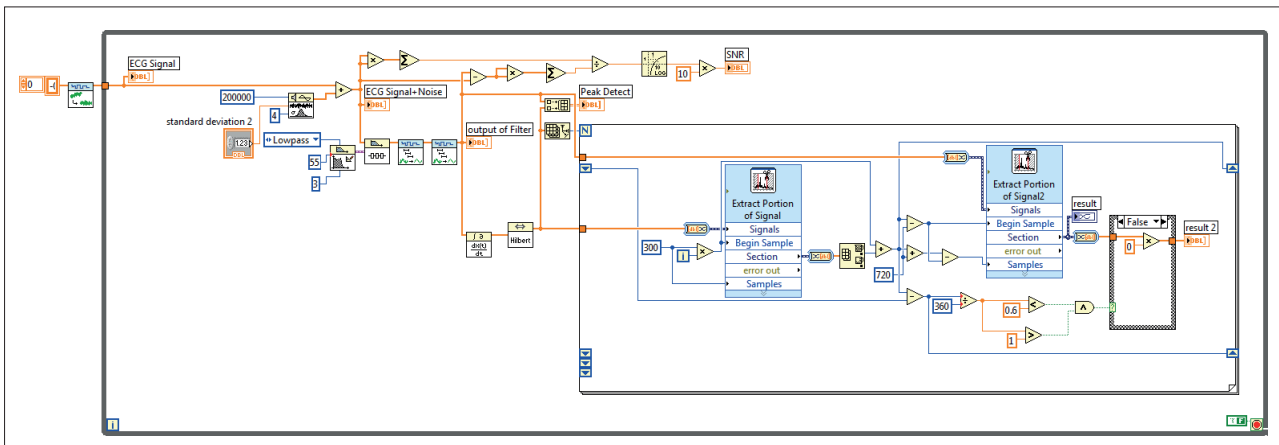

Figure 2. The algorithm of program

2.3. Preprocessing

The ECG signal contaminate with unwanted noise by instability environment record, false signals from nearby equipment, weak electrodes and electromagnetic noise. The noise of ECG signal depends on two reasons. First, the physical parameters of the instrument record. Second, bioelectric activity is not related to the areas of interest[6]. During the noise removal, we should be careful to retain the main features of the signal. Maintaining the features of signal is essential for correct diagnosis. Also, detecting P peaks, QT interval, T and S waves are considered important diagnostic parameters.

Several researches have survived the noise removal methods from the ECG signal. Our aim is to apply a method with the last amount of change in the real signal and low computational load for having a minimum of delay at execution time. In this research, the baseline noise is removed firstly. For this purpose, we estimate the trend of the signal with curve-fitting methods and then it decreases from the ECG signals. In

the next stage, an IIR low-pass filter is used to remove high frequency noise from the signal and it has 55 Hz cutoff frequency and third-order, chebyshev type. Finally, a two-stage moving average is performed to smooth out fluctuations. If we choose a high-order filter, we can access the best removal noise but it decreases the amplitude of R peak and it is not suitable.

Range of normal signal is $0 < RR < 0.6$, outside this range is considered abnormal[7]. The R peaks of ECG signal are required to determine RR interval. Most of the diagnostic methods of heart disease need accurate detection of R peaks. Thus, the R peak detection is an essential component in the analysis of heart diseases. A lot of researches have been done about peak detection of the ECG signal. Most of peak detection algorithms are based on filtering and threshold and the most famous one of them is Pan Tompkins algorithm[8]. The methods based on wavelet are used extensively in this field and a lot of researches have been done[9,10,11,12]. Methods such as First-Derivative, adaptive threshold, Hidden Markov model, Hilbert transform and some other are used to detect the R peak in the ECG signal too[13,14,15,16,17].

Each of these methods has advantages and disadvantages. The main objective of this research is accessing a program with real-time application. For this reason, Hilbert transform was used because it has short execution time and low computational complexity for R peak detection In the proposed al-

gorithm, a program which does not have large computational time is desirable because of that, it uses the first differential of the ECG signal and its Hilbert transformed data to locate the R peaks in the ECG signal. If the RR interval is not in the normal signal range, 2 seconds before and after the peaks will identify as abnormal signals.

$$HR=60/(RR/F_s) \quad (1).$$

- Heart rate is calculated by RR interval directly.
- RR is the interval between two consecutive peaks and F_s is the sampling frequency.

For an adult at rest, a normal heart beat is between 60 to 100 beats per minute. Although there is a wide range for normal heart beats, if the heart rate is unusually high or low, a crucial problem in the body can be seen. So, if the heart rate is above 100 beats per minute or less than 60 beats per minute at rest, it is required to consult with a physician.

2.4. Signal transmission

By using TCP/IP protocol, it is possible to connect multiple computers that use different operating systems. The network of computers can communicate with each other from a long distance. In other words, a person can have the information on a personal computer in one country by using this protocol. Then, he send the results to another computer in another country and can make sure of the accuracy of data transfer. However, there is no need for the computers on the network to be placed far apart. What is required in the communication protocol, is a suitable hardware and software for connection to a computer network. It should be noted that the networks should support the TCP/IP protocol.

IP protocol functions are similar to sending a letter via regular mail. There is no guarantee of getting a letter to the destination in the normal method. Also, there is no guarantee that the datagram is received by the destination node in the IP protocol. After the advent of TCP and when it was added to the IP protocol, TCP/IP will do the hand shaking and ensures a datagram is received by destination. TCP is a reliable transport without loss of information, and requires no repetition. There are two basic steps in writing program.

1. Receiving a signal
2. Signal transmission via the TCP/IP protocol

length of the transmitted data must be specified via TCP/IP protocol. The specified length is determined by the number of data packets. Transfer time depends on the amount of information packets that are sent. By giving an integer to the packet data, we will be sure that the data is sent without loss of information.

TCP is a reliable protocol which ensures data packets are received and will be used in applications with high sensitivity. TCP protocol is used in medical systems because of reliability of reception of the patients’s medical information[18].

3. RESULTS AND DISCUSSION

In present study, the ECG signal was contaminated by the additive Gaussian noise. The noise generator provides the noise in different standard deviations from 0.05 to 0.2. Signal to noise ratio is the ratio of signal power to noise power and the criterion to measure the noise cancelling.

The results of SNR for filtering method illustrate in table 1. A higher number is a better indicator of the noise removal. SNR of the proposed method shows a good performance of filtering.

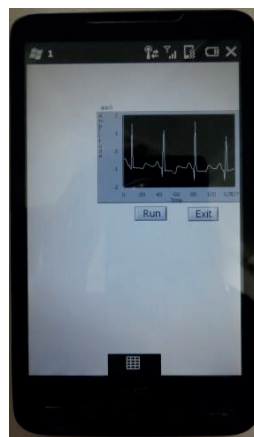

Figure 3. Display of ECG Signal on the mobile

$$SNR_{imp} [dB] = 10 \log_{10} \frac{\sum_{n=1}^N |x[n]|^2}{\sum_{n=1}^N |x[n] - \hat{x}[n]|^2} \quad (2).$$

$x[n]$ is real signal and $\hat{x}[n]$ is filtered signal

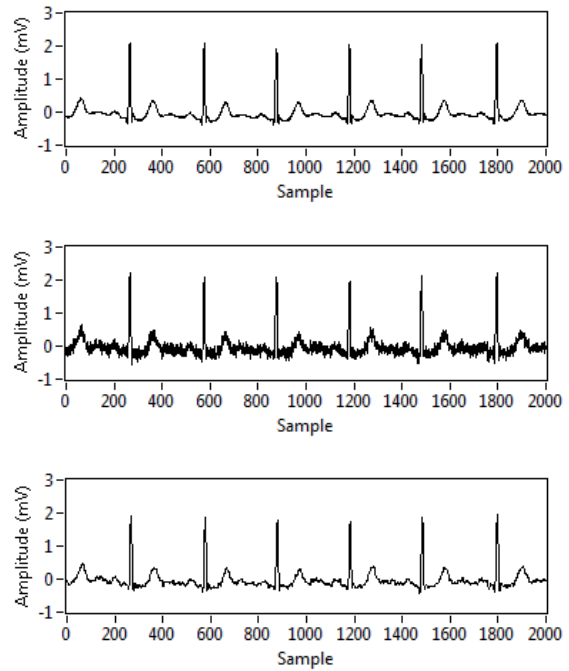

Figure 4. Illustrates the performance of filtering. a) ECG signal, from record 103. b) ECG signal with additive Gaussian noise. c) Noise reduction output

SNR : Mean (dB)	Standard Deviation
10.00	0.05
8.77	0.1
7.50	0.15
6.40	0.2

Table 1. SNR for MIT database, with different levels of the input standard deviation

Two statistical parameters are defined to compare detection algorithms: sensitivity and positive predictivity. The sensitivity is used for evaluating the ability of the algorithm to detect true beats, the positive predictivity is used for evaluating the ability of the algorithm to discriminate between true and false beats. The table 2 compares the various methods for QRS detection.

$$Sen = \frac{TP}{TP + FN} \quad (3).$$

$$P_+ = \frac{TP}{TP + FP} \quad (4).$$

TP=Number of true positive beat detected
 FP= Number of false positive beat
 FN= Number of false negative beat

	Se (%)	+p(%)
Pan and Tompkins [9]	99.76	99.56
Zidelma [10]	99.64	99.82
Andreao[15]	99.79	99.96
Kim [16]	100	100
This work	96.97	95.63

Table 2. Comparison performance of algorithm with other algorithms

After the ECG signals are processed by a mobile phone,

they are sent to a medical center for real-time diagnosis and monitoring by physician through TCP/IP protocol. In this algorithm, the data is saved in a file and then transferred to the destination without any delay.

4. CONCLUSIONS

Recent technological advances, especially that of the mobile phone have had the possibility of developing health care systems with the aim of monitoring the health status of patients. In this paper, a software program is designed to receive the ECG signal, real-time process it in the mobile phone and then transfer to a remote medical center. A diagnostic software program is designed to help physicians and medical assistants who have problems in distinguishing ECG and work in deprived regions. The main objective is to access optimized method to eliminate noise of the signal and maintain important property of ECG signal and monitor the patient round the clock. Heart rate is a vital signal to determine a patient's health status. With continuous measurement, we can be successful in early and rapid diagnosis of two major adverse cardiac disorder such as bradycardia (decreases in heart rate) and tachycardia (increase in heart rate). Primary experiments had successful results for our health care system. The patient can install the program on his mobile phone (windows mobile) and his heart condition is controlled all day long.

CONFLICT OF INTEREST: NONE DECLARED.

REFERENCES

1. Singh BN, Tiwari AK. Optimal selection of wavelet basis function applied to ECG signal denoising. *Digital Signal Processing*. 2006;16(3):275-87.
2. <http://www.who.int/mediacentre/factsheets/fs317>
3. Engin M, Çağlav E, Engin EZ. Real-time ECG signal transmission via telephone network. *Measurement*. 2005;37(2):167-71.
4. Ackerman MJ, Filart R, Burgess LP, Lee I, Poropatich RK. Developing Next-Generation Telehealth Tools and Technologies: Patients, Systems, and Data Perspectives. *Telemedicine Journal and e-Health*. 2010;16(1):93-5.
5. MIT-BIH ECG database, <<http://www.physionet.org/physiobank/database>>
6. Wu Y, Rangayyan RM, Zhou Y, Ng S-C. Filtering electrocardiographic signals using an unbiased and normalized adaptive noise reduction system. *Medical Engineering and Physics*. 2009;31(1):17-26.
7. Reddy DC. *Biomedical signal processing: principles and techniques*. Tata McGraw-Hill Education; 2005 [chapter7]
8. Pan J, Tompkins WJ. A Real-Time QRS Detection Algorithm. *IEEE Transactions on Biomedical engineering*. 1985;32(3):230-6.
9. Zidelmal Z, Amirou A, Adnane M, Belouchrani A. QRS detection based on wavelet coefficients. *Computer Methods and Programs in Biomedicine*. 2012;107(3):490-6.
10. Mohammed Abo-Zahhad, Sabah M. Ahmed, and Ahmed Zakaria, "An Efficient Technique for Compressing ECG Signals Using QRS Detection, Estimation, and 2D DWT Coefficients Threshold," *Modelling and Simulation in Engineering*, vol. 2012.
11. Almeida R, Goncalves H, Bernardes J, Rocha AP. Fetal QRS detection and heart rate estimation: a wavelet-based approach. *Physiological Measurement*. 2014;35(8):1723-35.
12. Abidullaev B, Seo HD. A new QRS Detection Method Using Wavelets and Artificial Neural Networks. *Journal of Medical Systems*. 2011;35(4):683-91.
13. Arzeno NM, Deng Z-D, Poon C-S. Analysis of First-Derivative Based QRS Detection Algorithms. *IEEE Transactions on Biomedical Engineering* 2008;55(2):478-84.
14. Andreao RV, Dorizzi B, Boudy J. ECG signal analysis through hidden Markov models. *IEEE Transactions on Biomedical engineering*. 2006;53(8):1541-9.
15. Kim H, Yazicioglu RF, Merken P, Hoof CV, Yoo H-J. ECG Signal Compression and Classification Algorithm With Quad Level Vector. *IEEE Transactions on Information Technology in Biomedicine*. 2010;14(1):93-100.
16. Mukhopadhyay SK, Mitra M, Mitra S. QRS complex identification using Hilbert transform, variable threshold and slope reversal. *International Journal of Biomedical Engineering and Technology*. 2012;9(4):301-15.
17. Elgendi M, Eskofier B, Dokos S, Abbott D. Revisiting QRS Detection Methodologies for Portable, Wearable, Battery-Operated, and Wireless ECG Systems. *PLOS One*. 2014;9(1):1-18.
18. Pandian PS, Safeer KP, Shakunthala DTI, Gopal P, Padaki VC. Store and Forward Applications in Telemedicine for Wireless IP Based Networks. *Journal of Networks*. 2007;2(6):58-65.