

THE HUMAN COMPLEMENT SYSTEM IN THROMBIN-MEDIATED PLATELET FUNCTION*

BY MARGARET J. POLLEY AND RALPH NACHMAN

(From the Department of Medicine, Cornell University Medical College, New York 10021)

The role of complement in blood coagulation is far from clear. A clotting abnormality was reported (1, 2) in rabbits deficient in the sixth component of complement (C6), however, no clotting abnormality was detected in a human patient deficient in the same component (3). When platelets were incubated in fresh human serum, C3 and C5-C9 complexes were demonstrated on the platelet membrane as well as C5-C9 complexes in the fluid phase of the reaction mixture (4). Further, retraction and lysis of thrombin-induced blood clots were inhibited by antiserum to C3 and C4 (5). We have previously reported (6) that complement-dependent ultrastructural lesions were visualized on the platelet surface subsequent to their incubation with thrombin and complement.

In the present study, thrombin-mediated specific uptake of C3 and C5 was demonstrated by uptake of radiolabeled components and was visualized ultrastructurally utilizing ferritin-conjugated monospecific antiserum to each of the two components. To develop these studies further, the role of complement in thrombin-induced platelet function was investigated. It was found that whereas complement was not essential for thrombin-mediated platelet aggregation and release of serotonin, these two activities were much enhanced in the presence of complement. When the nature of the complement interaction was determined, it was found that components C3, C5, C6, C7, C8, and C9 were essential for this enhanced reactivity; however, these six components in the absence of any previously described C3 convertase were the only components of the complement system that were required. Evidence is presented identifying a new pathway of activation of complement—one that is dependent on the presence of thrombin and the platelet membrane and enters the known complement sequence at the C3 stage.

Materials and Methods

Preparation of Washed Platelets. A suspension of human platelets was prepared using the Ardlie buffer system as previously described (7) with the following modification. Because the pH of the Ardlie buffers was found rapidly to increase, the sodium bicarbonate in each buffer was replaced by Tris (hydroxymethyl) amino methane (Trizma base) at the same molarity, namely, 0.012 M. Under these conditions, the pH of the buffers remained constant at pH 7.3 throughout the experiment.

Preparation of Aluminum Hydroxide-Absorbed Serum. Fresh human serum was absorbed with aluminum hydroxide as previously described (6) under conditions that were shown to remove

* Supported by the National Institutes of Health through a specialized Center for Thrombosis grant (HL 18828) and the Arnold R. Krakower Foundation.

prothrombin but not to inactivate complement. Serum was considered to be prothrombin free if, after incubation with fibrinogen (1.5 mg/ml) for 48 h, no clot was formed. Assays were performed to measure activity of whole component and components of both the classic and alternative mechanism as previously described (6).

Preparation of Complement Components and Reagents. C3(8), C4(9), C5(8), C6, C7(10), C8(11), and C9(12) were prepared by methods described earlier. In addition, for some experiments purified complement components prepared by Cordis Laboratories, Inc. (Miami, Fla.) were utilized. C3a and C5a were produced by trypsin treatment of the parent molecule and molecular sieve chromatography (13, 14). Aluminum hydroxide (Al(OH)₃)-absorbed serum was further treated with potassium thiocyanate (KSCN)¹ under conditions known to inactivate C3, C4, and C5(15). In reconstitution experiments, 25 μg C3, 17 μg C4, and 3 μg C5 were added either singly or in combination to 10 μl of Al(OH)₃-absorbed KSCN-treated serum. A reagent that contained C3, C5, C6, and C7 and not C8 and C9 was also prepared (11).

Human serum totally deficient in C2 was kindly supplied by Doctors Kunkel and S. M. Fu (The Rockefeller University, New York). Factor B-depleted serum was prepared by heating fresh human serum at 50°C for 30 min (16). A serum reagent lacking C2 and Factor B was prepared by heating the C2-deficient serum at 50°C for 30 min. Each serum was absorbed with aluminum hydroxide as described above. In the case of the heated sera, the absorption with aluminum hydroxide was performed before the heating step.

Monospecific antisera to C2, C3, C5, C8, and C9 were prepared in rabbits by injection of the purified protein into the popliteal lymph nodes followed a month later by an intramuscular injection of the same protein (17). The antisera were extensively tested immunochemically for specificity and if they were found not to be monospecific, they were appropriately absorbed. Monospecific anti-human serum albumin and anti-Factor B were purchased from Behring Diagnostics, Inc. (Woodbury, N.Y.).

Platelet Aggregation. Assays for platelet aggregation were performed in a Payton dual channel aggregometer using a Riken Denshi recorder (Payton Associates Inc., Buffalo, N.Y.). Platelets were suspended at 200,000/μl in Ardlie II buffer in which bicarbonate had been replaced with Tris (see above). All reagents added to the platelets were dialyzed before use vs. cacodylate buffer pH 7.4, a buffer shown to be optimal for aggregation of washed platelets (18). Highly purified human thrombin (2.05 U/μg) was prepared and kindly supplied by Dr. John Fenton, New York State Department of Health, Albany, N.Y. 0.1 U in 10 μl was added to 0.3 ml washed platelets.

Release of ¹⁴C-Serotonin. Platelets suspended in plasma were labeled with ¹⁴C-serotonin by the method of Valdorf-Hansen and Zucker (19). The radiolabeled platelets were then washed in the usual way. For the experiment, 0.3 ml platelet suspension was utilized to which 10 μl aliquots of various reagents were added. Aggregation was recorded for 5 min, then the tube was centrifuged and the supernate removed. ¹⁴C was counted in both the supernate and the cell button in a Packard Liquid Scintillation counter (Packard Instrument Co., Inc., Downer's Grove, Ill.) and percent release was calculated.

Release of Lactic Dehydrogenase (LDH). LDH release was determined by the method of Wroblewski and LaDue (20). 1 U was expressed as decrease in OD at 340 μm of 0.001/min per ml. Release of LDH during incubation periods from 1 min to 2 h was determined.

Ferritin Conjugation of Antisera. Monospecific antisera to C3 and C5 were conjugated with ferritin by the method of Tawde and Ram (21). Free ferritin and unconjugated γ-globulin were separated from the conjugated γ-globulin by pevikon block electrophoresis (22).

Preparation of Platelets for Electron Microscopy. Complement was activated on the platelet surface by the methods described in detail below. After incubation with complement, the platelets were washed three times with saline. The platelet button was then suspended in a dilution of ferritin-conjugated antibody and incubated at 37°C for 30 min. After this incubation the platelets were washed three times in saline, then divided into two aliquots. One aliquot was then washed three times in a 1/10 dilution of saline buffered to pH 6.5. After the first wash step at this low ionic strength, the platelets were frozen and thawed twice to lyse them, and the unstained platelet membranes were viewed in a Philips 301 Electron Microscope (see Fig. 1). The second

¹ Abbreviations used in this paper: DFP, diisopropyl fluorophosphate; KSCN, potassium thiocyanate; LDH, lactic dehydrogenase.

aliquot of platelets was embedded, sectioned, and stained in the usual way and then viewed under the electron microscope (see Fig. 2).

Radiolabeling of Complement Components. C3 and C5 were labeled with ^{125}I by the method of McConahey and Dixon (23). The specific activity of C3 was approximately 200,000 cpm/ μg ; and of C5 was approximately 60,000 cpm/ μg .

Activation of Complement on the Platelet Surface. The serum concentration of C3 was assumed to be 1.3 mg/ml and of C5 80 $\mu\text{g}/\text{ml}$. For each experiment either 25 μl of ^{125}I -C3 containing 20.5 μg of protein or 25 μl of ^{125}I -C5 containing 5.25 μg was added to 0.25 ml of undiluted human serum. Complement was activated on the platelet surface by (a) the classic mechanism, (b) the alternative mechanism, and (c) by thrombin:

(a) Activation of complement by the classic mechanism: 0.5 ml of a platelet suspension at $1.5 \times 10^9/\text{ml}$ was incubated with 0.25 ml serum containing an isoantibody to a nonidentified platelet antigen and 0.25 ml of fresh serum containing either ^{125}I -labeled C3 or C5. After incubation at 37°C for 90 min, the tubes were spun and the cell button was washed five times with saline before counting.

(b) Activation of complement by the alternative mechanism: 0.25 ml of the platelet suspension was mixed with 0.25 ml of inulin at 10 mg/ml. The mixture was centrifuged and the supernate was discarded. To the inulin-platelet mixture was added 0.25 ml serum containing either ^{125}I -C3 or ^{125}I -C5. After incubation at 37°C for 90 min, the tubes were centrifuged and the cell button was washed five times with saline.

(c) Activation of complement with thrombin: 0.5 ml of the platelet suspension was mixed with 0.25 ml serum containing 0.25 U of thrombin and ^{125}I -C3 or C5. After incubation at 37°C for 90 min, the tubes were centrifuged and the cell button was washed five times with saline.

In an experiment to determine the role of the platelet in the activation of complement by thrombin, a similar method was used except that the platelets were replaced by either human erythrocytes at $5 \times 10^8/\text{ml}$ or leukocytes at $5 \times 10^7/\text{ml}$. The leukocyte preparation was the supernate from dextran-sedimented defibrinated whole blood.

In each of the above experiments the negative control for nonspecific uptake of radiolabeled complement component was supplied by a similar reaction mixture containing 0.01 M EDTA. In each case this figure was subtracted from the total uptake to provide specific uptake.

Inhibition of Aggregation and Release of Serotonin by Monospecific Antisera. Monospecific antisera to C2, C3, C5, C9, Factor B, and human serum albumin were utilized. 0.2 ml of each antiserum was applied to a *O*-triethylaminoethyl-cellulose column equilibrated with phosphate buffer pH 8.0 and 0.0175 M. The γ -globulin fraction was eluted with the same buffer. The fraction containing the peak of γ -globulin was used in an unconcentrated form. 0.3 ml was incubated at 37°C for 15 min with 20 μl of antibody. Subsequent to this incubation, the tube containing the antibody-platelet mixture was transferred to the platelet aggregometer, and 10 μl samples of various complement components or reagents were added (see Results). The anti-human serum albumin was used in each experiment as the negative control.

Treatment of Thrombin with Diisopropyl Fluorophosphate (DFP). DFP at a final concentration of 2×10^{-3} M was added to thrombin at 100 U/ml. The mixture was allowed to stand at 0°C for 30 min then was dialyzed extensively vs. normal saline.

Results

Uptake of ^{125}I -C3 and ^{125}I -C5 by Platelets. As shown in Table I, activation of complement on the platelet surface by either the classic or the alternative pathway led to uptake of 40–60,000 molecules of C3 per cell and 3–4,000 molecules of C5. However, incubation of platelets with complement in the presence of thrombin led to a similar uptake of C5 but to a much reduced uptake of C3.

Incubation of complement with erythrocytes or leukocytes in the presence of thrombin led to an uptake of C3 and C5 that was not distinguishable from the EDTA-containing control.

Morphologic Demonstration of Thrombin-Induced Uptake of C3 and

TABLE I
*Uptake of C3 and C5 by Platelets When Complement is Activated
 by Three Different Mechanisms*

| Activation of comple- ment induced by* | Number of molecules per platelet | |
|---|----------------------------------|-------|
| | C3 | C5 |
| Antibody | 39,800 | 4,200 |
| Inulin | 61,600 | 2,900 |
| Thrombin | 4,400 | 3,600 |

* For details of method of activation of complement, see text.

C5. Distribution of ferritin conjugated to anti-C3 or anti-C5 on the surface of the platelet membrane is shown in Fig. 1. When complement was activated by thrombin, the amount of bound labeled anti-C3 was minimal as compared to the uptake when complement was activated by either the classic (Fig. 1c) or alternative mechanism (not shown). The platelet membranes from the thrombin-mediated reaction demonstrated large areas totally devoid of ferritin, and the ferritin when present was found to be localized in large clusters of 20-30 molecules. The uptake and distribution of ferritin conjugated to anti-C5 (Fig. 1b) were similar to that seen when complement was activated on the platelet surface by the antibody-mediated classic mechanism (Fig. 1d). Fig. 2a and b are stained sections of platelets reacted with thrombin and complement reacted with ferritin-conjugated anti-C3 (Fig. 2a) or anti-C5 (Fig. 2b).

Mechanism of Activation of Complement by Thrombin. We have previously reported (6) that subsequent to the incubation of platelets, thrombin, and a source of complement, ultrastructural lesions can be visualized on the surface of the platelet. To elucidate the mechanism of activation of complement, platelets were incubated with thrombin in the presence of serum from a patient deficient in C2. Ultrastructural lesions were still seen on the platelets, indicating that this total blockage of the classic mechanism had not prevented formation of the lesions. A blockage of the alternate pathway was initiated by heating serum at 50°C for 30 min to inactivate Factor B. Platelets incubated in heated serum in the presence of thrombin still exhibited ultrastructural lesions.

The Effect of Aluminum Hydroxide-Absorbed Serum on Thrombin-Induced Aggregation of Washed Platelets. Fig. 3 demonstrates aggregation of 0.3-ml platelets by 0.1 U of thrombin either in the presence (a) or absence (b) of 10 μ l of aluminum hydroxide-absorbed serum. The Al(OH)₃-absorbed serum in the absence of thrombin induced no platelet aggregation.

The Effect of Al(OH)₃-Absorbed Serum on Thrombin-Induced Release of Serotonin. Release of ¹⁴C-serotonin from platelets induced by varying amounts of thrombin either in the presence or absence of aluminum hydroxide-absorbed serum is shown in Table II. There was a two- to fourfold increase in the ¹⁴C-serotonin released by thrombin in the presence of the serum over that obtained with thrombin alone. This was most evident at the lower dose range of thrombin (0.025 and 0.05 U).

The Effect of Al(OH)₃-Absorbed Serum on Release of Lactic Dehydrogenase (LDH). Under the conditions utilized in the present study, namely 0.1 U

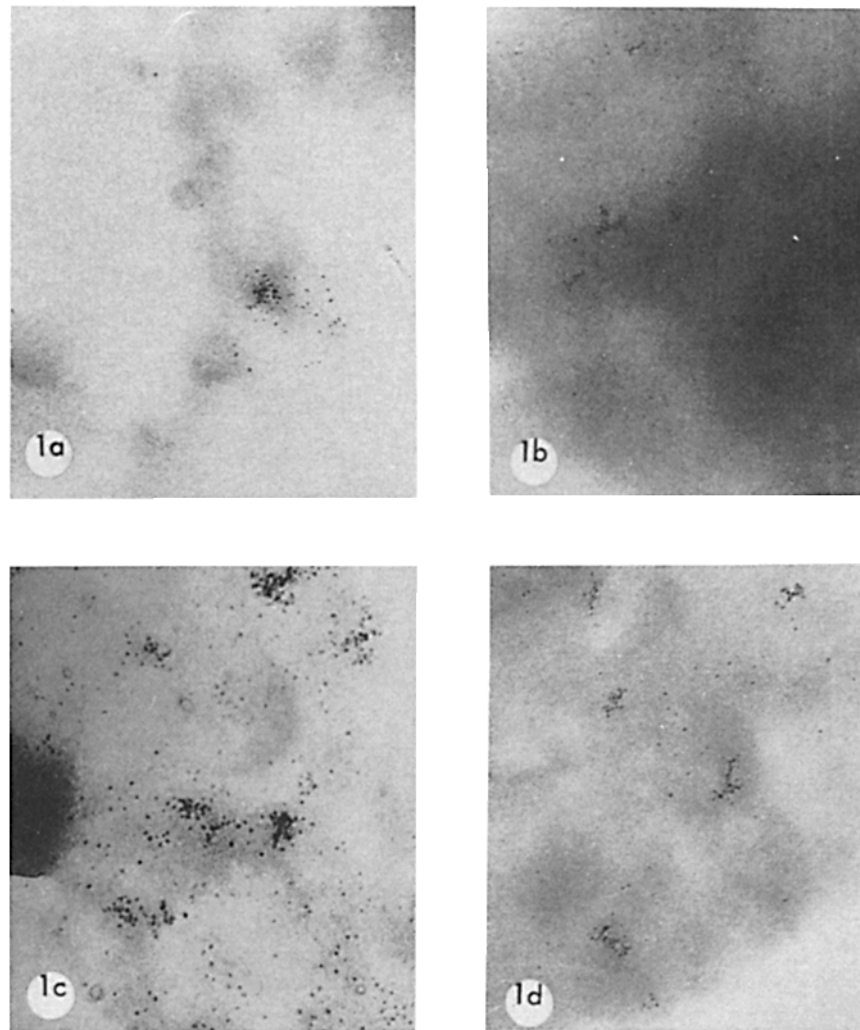

FIG. 1. Preparation of platelet membranes reacted with ferritin-conjugated antibody. Unstained. $\times 110,000$. (a and b): Complement activated by thrombin. (a) Anti-C3 conjugated with ferritin; (b) anti-C5 conjugated with ferritin; (c and d) complement activated by antibody-mediated classic mechanism; (c) anti-C3 conjugated with ferritin; (d) anti-C5 conjugated with ferritin.

thrombin per 0.3-ml platelets, no LDH was liberated from platelets by thrombin either in the presence or absence of aluminum hydroxide-absorbed serum even after an incubation period of 2 h at 37°C.

The Effect of KSCN Treatment of $Al(OH)_3$ -Absorbed Serum. $Al(OH)_3$ -absorbed serum when further treated with KSCN under conditions known to inactivate C3, C4, and C5 (15) failed to enhance significantly the release of serotonin by thrombin (Fig. 4). However, addition of 25 μg of highly purified C3 and 3.1 μg of C5 restored the enhancing ability of the serum. Addition of 17.6 μg of C4 had little or no effect.

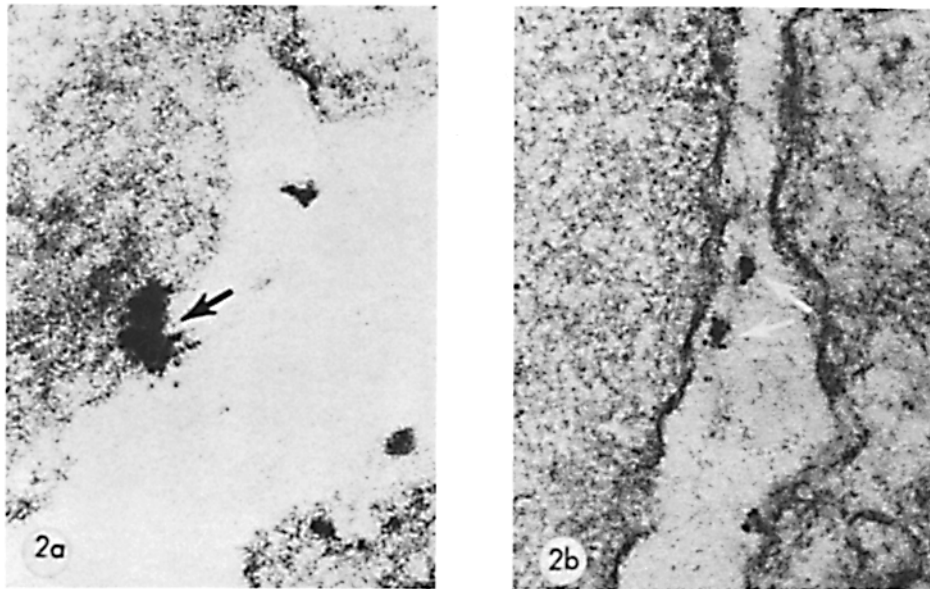

FIG. 2. Platelets reacted with thrombin and complement; then ferritin-conjugated antibody; sectioned and stained $\times 100,000$. Arrows indicate clumps of ferritin molecules. (a) Anti-C3 conjugated with ferritin; (b) anti-C5 conjugated with ferritin.

Use of Purified Complement Components in Platelet Aggregation and Release Reactions. Figs. 4 and 5 show the results of multiple experiments. The large standard deviations are the result of a considerable variation in the degree of agglutination and release of serotonin given by platelet preparations from different donors. Whether the difference is due to drugs, food, etc. in different donors was not determined. However, with a single batch of platelets on a given day, the trends were always reproducible.

The sequence of addition of thrombin and purified complement components was important in determining the extent of platelet ^{14}C -serotonin release. When thrombin was added before C3-C9, serotonin release was enhanced compared to the experiments in which C3-C9 was added before thrombin (Fig. 5). In multiple experiments, the highest degree of serotonin release was obtained when C3, C5, C6, C7, C8, and C9 were added. However, some enhancement of release of serotonin was obtained when C3 alone was added or when C3 and C5 were added or when C3, C5, C6, and C7 were added. Some release enhancement was also noted in the presence of C8 and C9. Despite the large standard deviation, the enhancement of serotonin release by C3-C7 was always less than that produced by C3-C9 with any single batch of platelets.

As a result of these experiments, the question arose as to whether C8 and C9 were bound to the platelet surface and were being utilized in the release reaction. To answer this question, 0.3 ml platelets were incubated with 20 μl of the γ -globulin fraction of anti-C9 for 15 min at 37°C. After this period the tube was transferred to the platelet aggregometer and 0.1 U of thrombin was added, followed by 10 μl each of C3, C5, C6, and C7. It was found that the enhancement of aggregation and release initiated by C3-C7 was totally abolished by incuba-

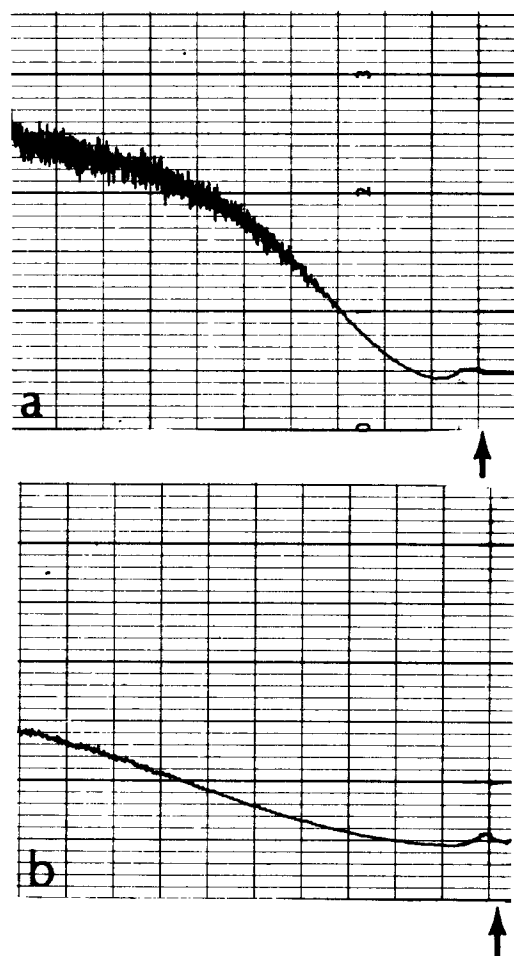

FIG. 3. Platelet aggregometer tracing of thrombin-mediated platelet aggregation: (a) 0.3 ml washed platelets in the presence of 10 μ l of aluminum hydroxide-absorbed serum; (b) 0.1 U thrombin-0.3 ml washed platelets. Arrow indicates addition of thrombin.

TABLE II
Comparison of Thrombin-Induced Release of 14 C-Serotonin in the Presence and Absence of Complement

| Units of thrombin* | Al(OH) ₃ absorbed serum \ddagger | Release of 14 C-serotonin |
|--------------------|---|--------------------------------|
| | | % |
| 0.025 | - | 0 |
| 0.05 | - | 26 |
| 0.1 | - | 59 |
| 0.025 | + | 28 |
| 0.05 | + | 64 |
| 0.1 | + | 65 |

* Added to 0.3 ml of washed platelets.

\ddagger 10 μ l added.

COMPLEMENT AND PLATELET FUNCTION

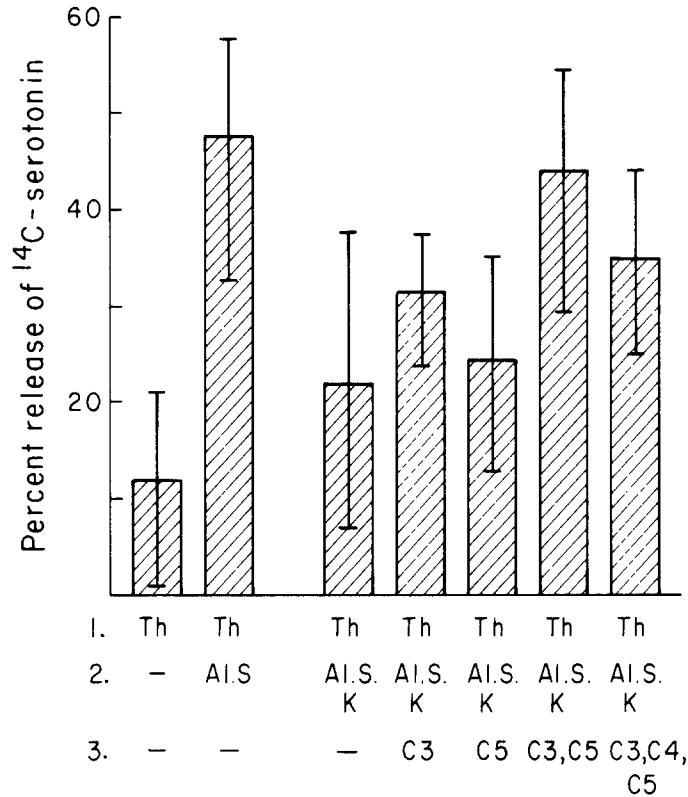

FIG. 4. Effect of various reagents on thrombin-induced release of platelet serotonin. Th, thrombin; Al.S, fresh human serum absorbed with aluminum hydroxide; Al.S.K., fresh human serum absorbed with aluminum hydroxide then treated with potassium thiocyanate (see text). 1 and 2 indicate sequence of addition.

tion of the platelets with anti-C9. When anti-C9 was replaced by anti-human serum albumin, there was no effect on subsequent platelet reactivity. The enhancement of aggregation or release by C8 and C9 alone was similarly inhibited by antisera to either C3 or to C5 (Fig. 6).

Thus C3, C5, C6, C7, C8, and C9, when mixed together in the absence of any known activating components of the classic or alternative mechanism, produced an enhancement of thrombin-induced aggregation and release equivalent to that induced by $\text{Al}(\text{OH})_3$ serum.

Mechanism of Activation of Complement by Thrombin. The observation that addition of C3, C5, C6, C7, C8, and C9 in the absence of any known activator of complement led to enhanced thrombin-induced aggregation and release of serotonin, suggested the possibility that complement was activated by a method distinct from the known classic or alternative mechanisms. To clarify this possibility, serum reagents were utilized in which a key component of either system was absent. The serum totally deficient in C2 was utilized as a serum in which the classic mechanism was inhibited. As shown in Fig. 7, when this serum was absorbed in the usual way with aluminum hydroxide and utilized as a source of complement, thrombin-induced release of serotonin was

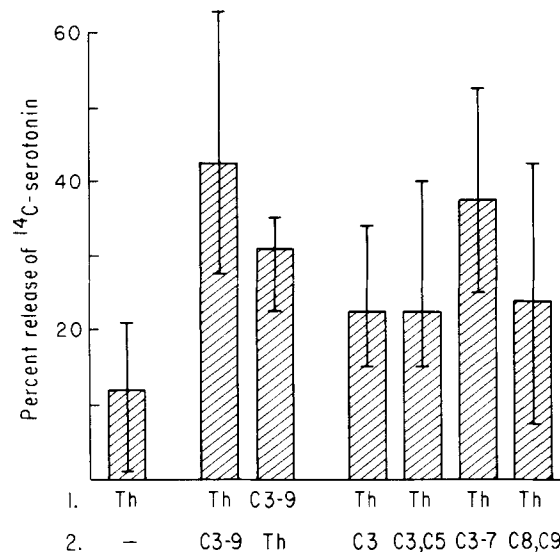

FIG. 5. Effect of various reagents and purified complement components on thrombin-induced release of platelet serotonin. C3-C7: complement components C3, C5, C6, C7. C3-C9: complement components C3, C5, C6, C7, C8, and C9. Other abbreviations are the same as in the legend to Fig. 4

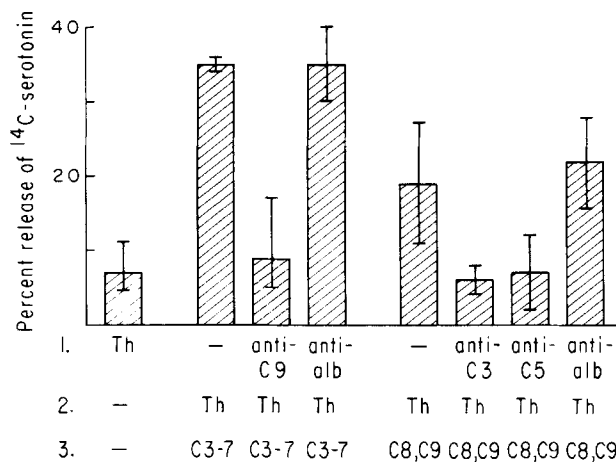

FIG. 6. The effect of antibody on thrombin-induced release of platelet serotonin, 1, 2, and 3 indicate sequence of addition. Anti-alb: anti-human serum albumin. For methodology, see text.

equal to that obtained with C2-sufficient normal serum. A blockage of the alternative mechanism was produced by heat inactivation (50°C, 30 min) of Factor B. Aluminum hydroxide-absorbed heated serum was indistinguishable from unheated serum in mediating release of serotonin. Further, blockage of both the classic and alternative mechanisms was produced by heating at 50°C for 30 min the C2-deficient serum that had been absorbed with aluminum hydroxide. This serum reagent was also indistinguishable from normal serum

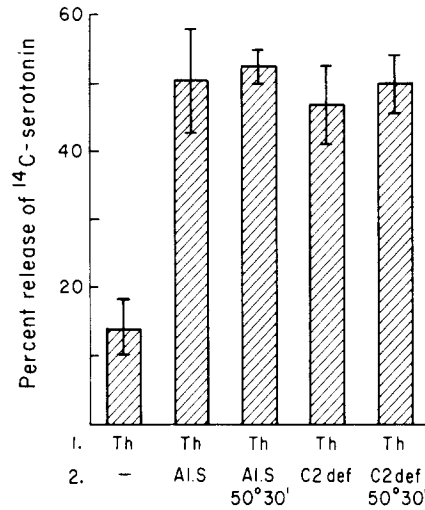

FIG. 7. Effect of various reagents on thrombin-induced release of platelet serotonin. C2 def, serum from patient deficient in C2 absorbed with aluminum hydroxide. C2 def 50°C30', serum from patient deficient in C2 absorbed with aluminum hydroxide, then heated at 50°C for 30 min. Other abbreviations are the same as in the legend to Fig. 4.

in inducing enhancement of thrombin-induced release of serotonin. Platelet aggregation in each experiment corresponded to serotonin release.

To ascertain whether platelet-bound C2 or Factor B were contributing to the release reaction in the absence of exogenous C2 or Factor B, experiments were performed in which the platelets were reacted with antibody to either C2 or Factor B before they were exposed to C2-deficient serum, Factor B-depleted serum, or C2-deficient serum that had been heated. Neither antibody caused any decrease in the platelet aggregation or release of serotonin.

DFP Treatment of Thrombin. Treatment of thrombin with DFP totally inhibited its ability to aggregate platelets and to release serotonin both in the presence and absence of complement.

Discussion

In a previous communication (6), we demonstrated the presence of ultrastructural lesions on the surface of platelets that had been incubated with thrombin and complement. We showed that these morphologic membrane perturbations were dependent on the presence of thrombin and C3. In the present study we have extended these studies and demonstrated cellular uptake of C3 and C5 by the platelets and have investigated the role of complement in thrombin-mediated platelet functions.

Utilizing radioactively labeled C3 and C5, we were able to demonstrate both C3 and C5 on the platelet surface. The uptake of C3 was very much less than the uptake seen when complement was activated on the platelet surface by either the classic mechanism or the alternative mechanism. However, the uptake of C5 was similar to that produced by activation of the classic mechanism. That the platelet membrane was an integral component of this reaction was demonstrated by the finding that a similar activation of complement and

uptake of C3 and C5 was not seen when the platelets were replaced with either erythrocytes or leukocytes.

The uptake and spatial organization of these components were visualized utilizing ferritin conjugated to anti-C3 or anti-C5 and electron microscopy. Whereas the uptake of ferritin conjugated to anti-C5 was similar to that found when complement was activated by the classic mechanism, the uptake of ferritin conjugated to anti-C3 was totally different from that seen when complement was activated by either the classic or the alternative mechanism. When complement was activated by the antibody-mediated classic mechanism, the distribution of the C3 ferritin marker was similar to that published (24) for its distribution on erythrocytes. However, after thrombin-mediated complement activity, there were very few molecules of C3 per cell. In fact, the number of C3 molecules approximated the number of C5 molecules, whereas when complement was activated by the classic mechanism, a 10-fold greater number of C3 molecules was obtained than of C5 molecules, and by the alternative mechanism a 20-fold difference was seen. When the molecules were visualized on the platelet surface utilizing a ferritin marker, it was found that large areas of the platelet membrane had no C3 and the C3 that was present was focalized in large clusters visualized as 20-30 ferritin molecules.

Zimmerman and Kolb (4) have reported uptake of C3 and the C5-C9 complex when platelets are incubated in serum. However, it is not clear whether the mechanism of uptake is the same as that demonstrated in the present study.

The results of our studies led us to investigate the role of complement in thrombin-mediated platelet function. Initially in these studies we utilized aluminum hydroxide-absorbed serum as a source of complement. With this reagent we found increased platelet aggregation and release of serotonin in the presence of complement. That the release of serotonin was a nonlytic process was demonstrated by the finding that no lactic dehydrogenase was liberated during this reaction. A role for complement in thrombin-mediated platelet function has been previously suggested (5). These authors demonstrated that retraction and lysis of thrombin-induced blood clots were found to be inhibited by monospecific antisera to C3 and C4. Also thrombin was shown to cleave C3 into C3a-like and C3b-like peptides. However, the C3a produced by cleavage of C3 with thrombin had no anaphylatoxin activity (14).

The use of purified components of complement in place of aluminum hydroxide-absorbed serum as a source of complement demonstrated that maximum thrombin-induced platelet aggregation and release could be achieved by the addition of C3, C5, C6, C7, C8, and C9 in the absence of any previously described C3 convertase. Further, the sequence of addition of thrombin and complement was important. Considerably more serotonin was released when thrombin was added before the components of complement than when the components were added before the thrombin. All six components were required for maximal aggregation and release. However, C3, C5, C6, and C7 induced a considerable enhancement over that obtained with thrombin in the absence of complement. The release induced by C3-C7 was facilitated by platelet-bound C9 (and probably C8) as demonstrated by the fact that the C3-C7 reactivity was inhibited if the platelets were first treated with anti-C9 (Fig. 6). Some enhancement of release was obtained when C8 and C9 alone were added. That this release was

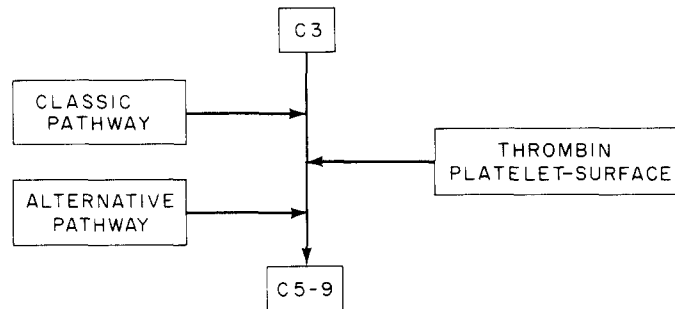

FIG. 8. Complement activation mechanisms. A new third pathway.

due to the presence of platelet-bound C3 and C5 was evidenced by the finding that it was inhibited by anti-C3 and anti-C5.

Thus the data suggest that thrombin and the platelet membrane generate a C3 convertase that is distinct from those previously described as a consequence of the activation of the classic or alternative mechanism. Because the sequence of addition of thrombin and C3-C9 is important, it appears that if thrombin is allowed first to interact with the platelet (presumably the thrombin-receptor; 25-27), this interaction brings the activation of the C3-C9 onto the platelet surface in contrast to the reaction taking place in the fluid phase. It will be of some interest in the future to determine whether the membrane attack complex (C5b-C9) is assembled on the platelet surface as a consequence of thrombin action.

Confirmatory data for lack of activation of either the classic mechanism or the alternative mechanism were obtained in experiments in which C2-deficient or Factor B-depleted serum was used. These sera, used as a source of complement, induced enhancement of thrombin-mediated aggregation and release of serotonin which was indistinguishable from that obtained with normal serum. Cell-bound C2 or Factor B was not responsible for this reactivity because prior treatment of the platelets with the corresponding antibody had no effect on the reactivity of the sera. We suggest, as illustrated in Fig. 8, that there exists a third mechanism leading to the activation of complement. This pathway requires thrombin and the platelet membrane and enters the known complement sequence at the C3 stage. It will be of great interest to determine whether other platelet membrane perturbants, such as collagen or ADP, have similar properties. Complement is not essential for thrombin-mediated platelet function; however, considerable enhancement of its reactivity can be obtained by the addition of C3, C5, C6, C7, C8, and C9.

Summary

Thrombin-mediated platelet membrane-specific uptake of C3 and C5 was demonstrated by radiolabeled components and was visualized electron microscopically utilizing a ferritin marker conjugated to monospecific antibody to each component. The role of complement in thrombin-induced platelet function was determined. Though complement was not essential for thrombin-induced platelet aggregation and release of serotonin, these activities were significantly

increased if complement was present. The release of serotonin was found to be a nonlytic process because under the conditions employed, no lactic dehydrogenase was released. The activation of complement was induced by a mechanism which has not been previously described. Thrombin associated with the platelet membrane presumably formed a C3 convertase that entered the known complement sequence at the C3 stage and proceeded to activate the terminal components through the known sequence to C9.

The authors gratefully acknowledge the skillful technical assistance of Ms. Eileen Cotty, Ms. Bonnye Benjamin, and Ms. Linda Metakis.

Received for publication 17 January 1978.

References

1. Zimmerman, T. S., C. M. Arroyave, and H. J. Müller-Eberhard. 1971. A blood coagulation abnormality in rabbits deficient in the sixth component of complement (C6) and its correction by purified C6. *J. Exp. Med.* 134:1591.
2. Zimmerman, T. S., and H. J. Müller-Eberhard. 1971. Blood coagulation initiation by a complement-mediated pathway. *J. Exp. Med.* 134:1601.
3. Hensinkveld, R. S., J. P. Leddy, M. R. Klemperer, and R. T. Breckenridge. 1974. Hereditary deficiency of the sixth component of complement in man. II. Studies of hemostasis. *J. Clin. Invest.* 53:554.
4. Zimmerman, T. S., and W. P. Kolb. 1976. Human platelet-initiated formation and uptake of the C5-9 complex of human complement. *J. Clin. Invest.* 57:203.
5. Taylor, F. B., and H. F. Müller-Eberhard. 1970. Qualitative description of factors involved in the retraction and lysis of dilute whole blood clots and in the aggregation and retraction of platelets. *J. Clin. Invest.* 49:2068.
6. Polley, M. J., and R. L. Nachmann. 1975. Ultrastructural lesions on the surface of platelets associated with either blood coagulation or with antibody-mediated immune injury. *J. Exp. Med.* 141:1261.
7. Nachman, R. L., A. Hubbard, and B. Ferris. 1973. Iodination of the human platelet membranes. *J. Biol. Chem.* 248:2928.
8. Nilsson, U. R., and H. J. Müller-Eberhard. 1965. Isolation of β_{1F} globulin from human serum and its characterization as the fifth component of complement. *J. Exp. Med.* 122:277.
9. Müller-Eberhard, H. J., and C. E. Biro. 1963. Isolation and description of the fourth component of human complement. *J. Exp. Med.* 118:447.
10. Podack, E. R., W. P. Kolb, and H. J. Müller-Eberhard. 1976. Purification of the sixth and seventh component of human complement without loss of hemolytic activity. *J. Immunol.* 116:263.
11. Manni, J. A., and H. J. Müller-Eberhard. 1969. The eighth component of human complement (C8): isolation, characterization and hemolytic efficiency. *J. Exp. Med.* 130:145.
12. Hadding, U., and H. J. Müller-Eberhard. 1969. The ninth component of human complement: isolation, description and mode of action. *Immunology* 16:719.
13. Cochrane, C. G., and H. J. Müller-Eberhard. 1968. The derivation of two distinct anaphylatoxin activities from the third and fifth components of human complement. *J. Exp. Med.* 127:371.
14. Bokisch, V. A., H. J. Müller-Eberhard, and C. G. Cochrane. 1969. Isolation of a fragment (C3a) of the third component of human complement containing anaphylatoxin and chemotactic activity and description of an anaphylatoxin inactivator of

- human serum. *J. Exp. Med.* **129**:1109.
15. Dalmasso, A. P., and H. J. Müller-Eberhard. 1966. Hemolytic activity of lipoprotein-depleted serum and the effect of certain anions on complement. *J. Immunol.* **97**:680.
 16. Götze, O., and H. J. Müller-Eberhard. 1971. The C3-activator system: an alternate pathway of complement activation. *J. Exp. Med.* **134**:90s.
 17. Goudie, R. B., C. H. W. Horne, and P. C. Wilkinson. 1966. A simple method for producing antibody specific to a single selected diffusible antigen. *Lancet.* **II**:1224.
 18. Shuman, M. A., and P. W. Majerus. 1975. The perturbation of thrombin binding to human platelets by anions. *J. Clin. Invest.* **56**:945.
 19. Valdorf-Hansen, J. F., and M. B. Zucker. 1971. Effect of temperature and inhibitors on serotonin-¹⁴C release from human platelets. *Am. J. Physiol.* **220**:105.
 20. Wroblewski, F., and J. S. LaDue. 1955. Lactic dehydrogenase activity in blood. *Proc. Soc. Exp. Biol. Med.* **90**:210.
 21. Tawde, S. S., and J. Sri Ram. 1962. Conjugation of antibody to ferritin by means of p,p'-Difluoro-M,M'-dinitrodiphenyl sulphone. *Arch. Biochem. Biophys.* **97**:429.
 22. Müller-Eberhard, H. J. 1960. A new supporting medium for preparative electrophoresis. *Scand. J. Clin. Lab. Invest.* **12**:33.
 23. McConahey, P. J., and F. J. Dixon. 1966. A method of trace iodination of proteins for immunologic studies. *Int. Arch. Allergy Appl. Immunol.* **29**:185.
 24. Müller-Eberhard, H. J., U. R. Nilsson, A. P. Dalmasso, M. J. Polley, and M. A. Calcott. 1966. A molecular concept of immune cytolysis. *Arch. Pathol.* **82**:205.
 25. Brodie, G. N., N. L. Baenziger, L. R. Chase, and P. W. Majerus. 1972. The effects of thrombin on adenyl cyclase activity and a membrane protein from human platelets. *J. Clin. Invest.* **51**:81.
 26. Baenziger, N. L., G. N. Brodie, and P. W. Majerus. 1972. Isolation and properties of a thrombin-sensitive protein of human platelets. *J. Biol. Chem.* **247**:2723.
 27. Tollefsen, D. M., J. R. Feagler, and P. W. Majerus. 1974. The binding of thrombin to the surface of human platelets. *J. Biol. Chem.* **249**:2646.