

Crystal structure of trioxacarcin A covalently bound to DNA

Roland Pfoh¹, Hartmut Laatsch² and George M. Sheldrick^{1,*}

¹Lehrstuhl für Strukturchemie, Georg-August-Universität, Tammannstr. 4, 37077 and ²Institut für Organische und Biomolekulare Chemie, Georg-August-Universität, Tammannstr. 2, 37077 Göttingen, Germany

Received March 17, 2008; Revised and Accepted April 16, 2008

ABSTRACT

We report a crystal structure that shows an antibiotic that extracts a nucleobase from a DNA molecule ‘caught in the act’ after forming a covalent bond but before departing with the base. The structure of trioxacarcin A covalently bound to double-stranded d(AACCGTT) was determined to 1.78 Å resolution by MAD phasing employing brominated oligonucleotides. The DNA–drug complex has a unique structure that combines alkylation (at the N7 position of a guanine), intercalation (on the 3'-side of the alkylated guanine), and base flip-out. An antibiotic-induced flipping-out of a single, nonterminal nucleobase from a DNA duplex was observed for the first time in a crystal structure.

INTRODUCTION

Trioxacarcins were first isolated in 1981 from the marine-derived micro-organism *Streptomyces bottropensis* DO-45 (1,2). They are cytotoxic against various cancer cell lines, active against Gram-positive and Gram-negative bacteria and exhibit anti-malarial activity (3). Trioxacarcin A (Figure 1) contains a complex ring system that is attached to sugars at both ends, at the 4- and 13-positions, and causes it to exhibit intensive green fluorescence in solution; in powder form it is yellow. Nucleophilic attack of N7 of guanine opens the ‘epoxide (1)’ to form a covalent bond to the ‘guanine (2)’ in a DNA molecule (Figure 2). This alkylation is favored when a thymine is located on the 3'-side of guanine and does not take place when the guanine is terminal (4). Cleavage of this trioxacarcin–‘DNA (3)’ complex at 373 K results in the natural product ‘gutingimycin (4)’ (3,5), named after the ancient name for the city of Göttingen, leaving an abasic DNA. Presumably, this cleavage takes place under milder conditions *in vivo*.

Anthracyclines resemble trioxacarcin A in that they also contain a planar aromatic ring system with one or more

sugars attached to it, although they can only intercalate but not bind covalently to DNA. Some of them are used for the treatment of various cancer types, e.g. daunomycin (= daunorubicin) against leukemia. In DNA–daunomycin complexes, the positively charged amino sugar of daunomycin is positioned in the minor groove of DNA (6). The anthracycline nogalamycin has bulky sugar residues at both ends of the molecule that interact with both grooves of DNA (7). Pluramycin antibiotics (8) such as hedamycin (9) and altromycin B (10), and also psorospermin (11), are even more similar to trioxacarcin A because they contain in addition one or more epoxides and so can both intercalate and alkylate DNA; like trioxacarcin they bind covalently to the guanine N7. However, no crystal structures have been reported of such covalent antibiotic–DNA complexes.

To throw more light onto the stereochemical requirements for the covalent bond formation and subsequent elimination of a nucleobase, we have determined the structure of trioxacarcin A covalently bound to an oligonucleotide to 1.78 Å resolution by X-ray diffraction. Experimental phases were obtained by MAD experiments using isomorphous crystals containing brominated nucleotides. The crystal structure reveals an unexpected base flip-out at the intercalation site.

MATERIALS AND METHODS

Trioxacarcin A was obtained from the marine *Streptomyces* sp. isolate B8652 by fermentation (12). Oligonucleotides were purchased already purified by HPLC from biomers.net GmbH and used without further purification. Crystals were grown at 40°C in hanging drops by vapor diffusion; we found by experiment that the higher than usual temperature produced better quality single crystals. The solution in the reservoir contained 1.55 M tri-ammonium citrate (pH 7.0) and 30% v/v DMSO. The DNA–drug solution contained 2.5 mM DNA (single-strand concentration), 2.8 mM trioxacarcin A and 25% v/v methanol. The DNA–drug solution was

*To whom correspondence should be addressed. Tel: +49 551 393021; Fax: +49 551 3922582; Email: gsheldr@shelx.uni-ac.gwdg.de

prepared by mixing trioxacarcin A stock solution (containing 5.0 mM trioxacarcin A and 50% v/v methanol) with a 5.6 mM DNA solution in a 1:1 ratio at room temperature and incubation for 3 days at 4°C. The hanging drops prepared from 1 µl DNA-drug solution and 2 µl reservoir solution were equilibrated against 500 µl reservoir solution. Yellow tetragonal crystals grew within 24 h to a size of 0.2 × 0.1 × 0.05 mm. For data collection at 100 K in a nitrogen gas stream, the crystals were transferred to a cryosolution containing 1.55 M tri-ammonium citrate (pH 7.0), 30% v/v DMSO and 15% v/v glycerol. Three different oligonucleotides were used to obtain crystals as described above: native d(AACCGGTT) and brominated d(AACCGG^{5Br}UT) and d(AACCGGT^{5Br}U). In the brominated oligonucleotides thymidine is replaced by 5-bromodeoxyuridine.

The DNA–drug complex crystallized in space group P4₁22 with unit-cell $a = b = 37.60 \text{ \AA}$ and $c = 91.62 \text{ \AA}$. Data were collected at beamline 14.2 at BESSY, Berlin with a MAR-165 CCD detector. The crystals containing brominated oligonucleotides were used for two Br-MAD experiments. From both crystals, peak and

inflection datasets were collected, 180 frames for each dataset with a ϕ -rotation of 1° per frame (see Table 1 for crystallographic details). In order to avoid radiation damage, an 0.53 mm aluminium filter was used to decrease the intensity of the direct beam. In addition, a native dataset was collected to 1.78 Å resolution from a crystal containing the native oligonucleotide.

The datasets were integrated with HKL2000 (13) and the space group determined by XPREP (Bruker AXS, Madison WI, USA). SHELXD (14) was used for substructure solution by searching for two bromine atoms with a resolution cutoff at 2.6 Å. Substructure solution succeeded only with the d(AACCGG^{5Br}UT)-derivative, probably because the crystals diffracted better. SHELXE (15) was employed for phasing and density modification. In the experimental map, the position of thymine could be deduced from the bromine positions from the substructure solution and the anomalous maps calculated using SHELXE. It was also possible to recognize the drug in the experimental map (Figure 3A). The asymmetric unit consists of one complete duplex with two intercalated trioxacarcins. The graphics program COOT (16) was used for model building. The structure was refined isotropically with TLS constraints against the native dataset with REFMAC (17) to $R_{\text{work}} = 22.0\%$ and $R_{\text{free}} = 26.5\%$ (Figure 3B). Helical parameters were calculated with 3DNA (18). Figures 3 and 5–7 were generated using PYMOL (DeLano Scientific LLC, South San Francisco CA, USA).

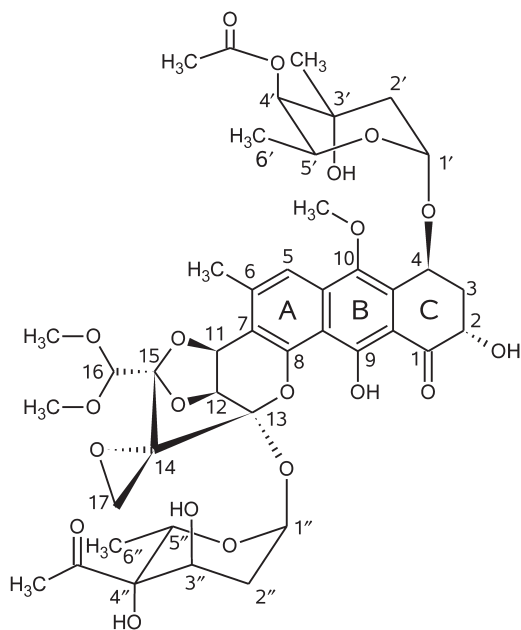

Figure 1. Schematic diagram of trioxacarcin A.

RESULTS AND DISCUSSION

Overall structure

As predicted in the study of the sequence specificity (4), trioxacarcin A binds covalently to d(AACCGGTT) by alkylating the N7 position of the guanine that is followed by a thymine. Unexpectedly, this thymine is flipped out of the duplex DNA and the adenine originally paired with it now forms a base pair with the following thymine in the sequence. Trioxacarcin A intercalates at the 3'-side of the alkylated guanine (Figure 4). The aromatic rings A and B of the drug are involved in stacking interactions with the DNA. As found for nogalamycin (7), trioxacarcin A interacts with both grooves of the DNA (Figure 5); the 4-sugar is positioned in the minor groove, the 13-sugar in the major groove.

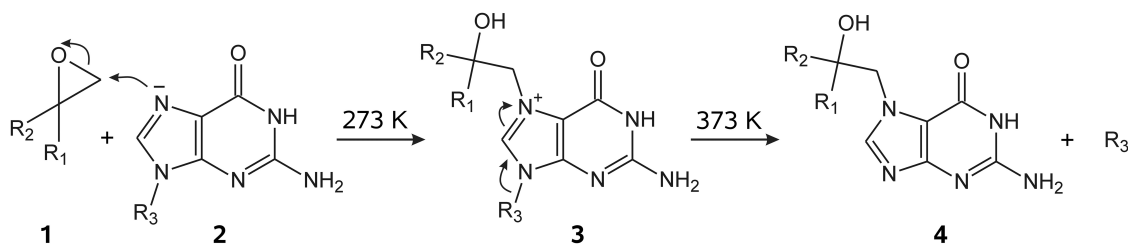
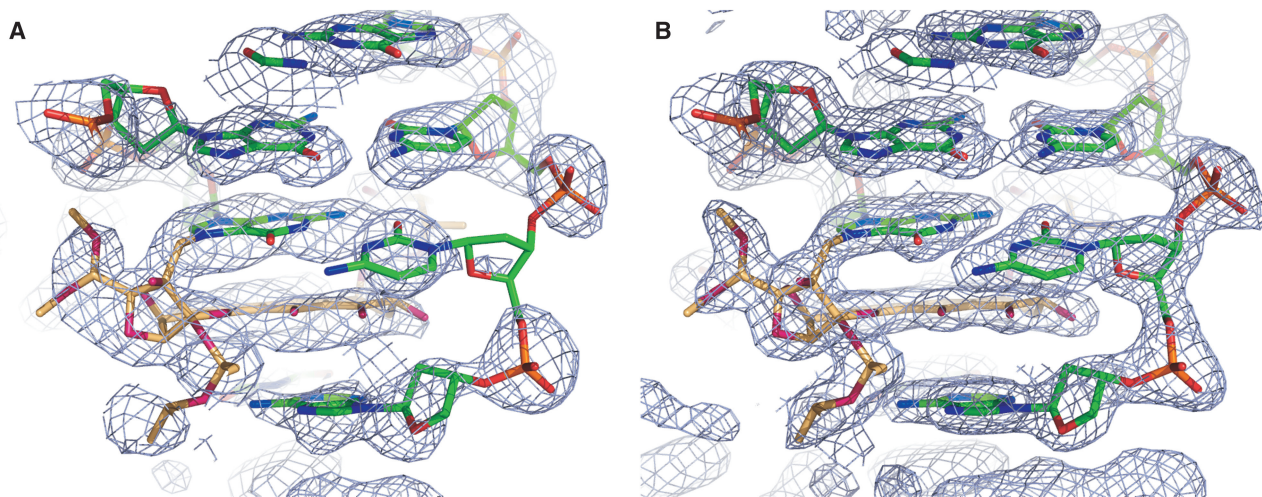

Figure 2. Proposed mechanism for the reaction of trioxacarcin A with DNA. Only the epoxide group of trioxacarcin A (1) is shown, the rest of the molecule is described by R_1 and R_2 . R_3 stands for the abasic DNA.

Table 1. Data collection, phasing and refinement statistics

	Native	d(AACCGG ^{5Br} UT)	d(AACCGGT ^{5Br} U)		
Crystal data					
Space group	P4 ₁ 22	P4 ₁ 22	P4 ₁ 22		
a, Å	37.60	37.60	37.56		
c, Å	91.62	91.21	90.97		
		Peak	inflection	peak	inflection
Diffraction data					
Wavelength, Å	0.92039	0.92032	0.92047	0.92033	0.92042
Resolution limit, Å	1.67	2.18	2.18	2.39	2.39
Total reflections	103 552	45 885	46 392	36 333	29 272
Unique reflections	8225	3789	3790	2917	2756
Completeness, %					
Overall	99.0	89.7	98.7	98.8	93.4
Outermost resolution shell	94.7	89.3	98.5	90.7	59.4
<i>I</i>/σ(<i>I</i>)					
Overall	27.81	13.2	14.6	13.8	14.8
Outermost resolution shell	2.92	4.5	4.2	2.7	1.5
Phasing					
Resolution, Å		2.6			
Pseudo-free CC after dm		0.61			
Refinement					
Reflections used	6488				
Resolution, Å	1.78				
<i>R</i> _{work}	22.0				
<i>R</i> _{free}	26.5				
rms deviation					
Bond length, Å	0.016				
Bond angles, °	2.5				
Average <i>B</i> factor (all atoms), Å ²	53.16				

**Figure 3.** Experimental map (A) and map after final refinement (B), both contoured at a 1σ level. The carbon atoms of the trioxacarcin are shown in light orange.

Since the duplex does not lie on a 2-fold axis, the two self-complementary strands are crystallographically independent, with some small structural differences caused by interactions of the residues A(1), A(101), T(7) and T(107), which are no longer base-paired within the duplex, with different symmetry related residues in the crystal.

A(1) forms a Hoogsteen base pair with a symmetry equivalent of T(7). In contrast, T(107) lies close to a symmetry equivalent of itself. Residue A(101) does not appear to make specific contacts to neighboring molecules and is highly disordered, whereas N1 of A(1) accepts an hydrogen bond (2.7 Å) from a symmetry equivalent of

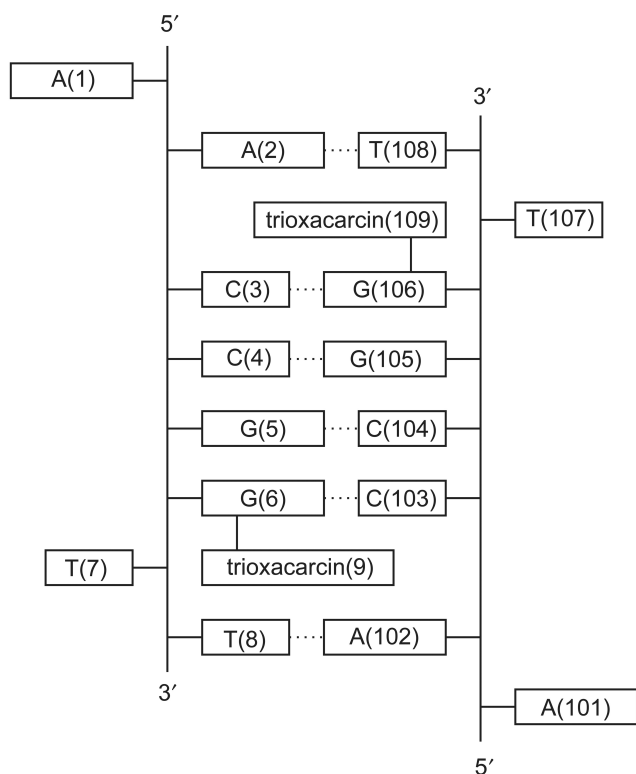

Figure 4. Simplified view of the DNA-trioxacarcin duplex with residue names.

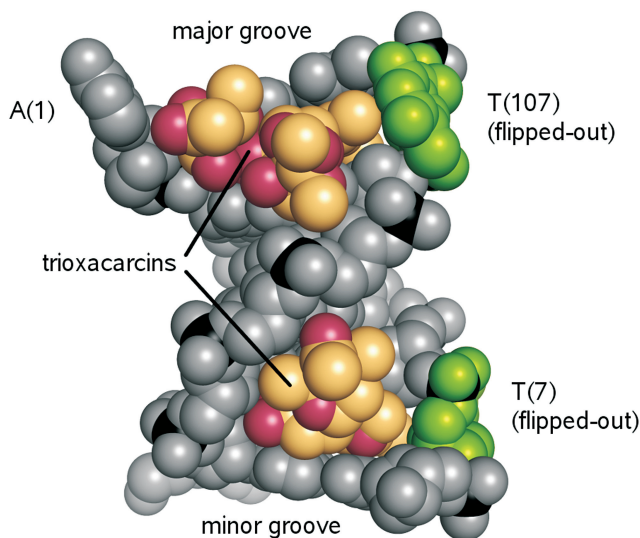

Figure 5. Space-filling view of the DNA-trioxacarcin duplex. Trioxacarcin is shown in red (oxygen atoms) and light orange (carbon atoms); the DNA is shown in light gray except for the phosphorus atoms that are shown in black and the two residues containing the flipped-out thymines in green. On the bottom is the minor groove enclosing the 4-sugar, on the bottom the major groove containing the 13-sugar (left side) and the two 16-methoxy groups (right-side). On the extreme upper left-side, the terminal A(101) can be seen.

4''-OH of trioxacarcin(109). The general conformations of both strands are fairly similar except for residues A(1) and A(101) that are positioned at the 5'-terminus of the oligonucleotide and do not base pair within the duplex.

The DNA-trioxacarcin duplex shows a distorted B-DNA geometry with Watson-Crick base pairing. In Table 2, the sugar-phosphate and glycosyl torsion angles are compared with the usual ranges and mean values for B-DNA (19). The flipping-out of T(7) is most evident in its ζ torsion angle of 82° [74° for T(107)] that differs by about 180° from the standard value. The other torsion angles all lie in ranges typically observed in B-DNA structures.

Antibiotic-DNA interactions

In addition to the covalent bond, trioxacarcin A forms direct and water mediated hydrogen bonds with the DNA (Figure 6). There is an hydrogen bond between the 2-OH of trioxacarcin and O4' of the deoxyribose attached to the cytosine opposite to the alkylated guanine [2.8 \AA for trioxacarcin(9) and 2.7 \AA for trioxacarcin(109)]. In the minor groove, N2 of the alkylated guanine donates an hydrogen bond to 3'-OH of the 4-sugar of trioxacarcin (3.1 \AA for both trioxacarcins). There is also a water-mediated hydrogen bond between N3 of the alkylated guanine and 3'-OH. The 4-sugar interacts only with the alkylated guanine. In the major groove, the 1''-oxygen of the 13-sugar of trioxacarcin(109) accepts an hydrogen bond (3.2 \AA) from N6 of residue A(2). In the case of trioxacarcin(9) and A(102), the corresponding hydrogen bond is mediated by a water molecule, giving rise to a small difference between the two strands. The 13-sugar is also involved in an internal hydrogen bond [3.4 \AA for trioxacarcin(9) and 3.1 \AA for trioxacarcin(109)] between 3''-OH and 14-OH (Figure 6), stabilizing the OH-group formed by the nucleophilic attack on the epoxide ring. The 13-sugar of the trioxacarcin is held parallel to the trioxacarcin chromophore by this internal hydrogen bond, whereas the 4-sugar is orientated perpendicular to it.

For the formation of gutingimycin, the guanine-sugar bond between N9 and C1' (Figure 7A) has to break and the antibiotic has to leave the DNA duplex taking the guanine with it. Assuming that the guanine-sugar bond breaks whilst the double strand is still intact, gutingimycin would then only be attached to the abasic DNA by two hydrogen bonds because one hydrogen bond involved a symmetry equivalent that would not be relevant in solution and the other two hydrogen bonds that held it in place are between the 4-sugar of the trioxacarcin and the guanine. After leaving, the guanine rotates by about 180° to give the conformation observed in the crystal structure of gutingimycin (5) that is stabilized by stacking interactions between the guanine and the chromophore; this would inhibit re-intercalation of the gutingimycin into the DNA. Figure 7B shows the crystal structure of gutingimycin (5) in a similar orientation to the bound trioxacarcin in the DNA-drug duplex (Figure 7A), illustrating the 180° rotation of the guanine base. N2 of this guanine lies above ring C in both structures. In the DNA-drug complex, N3 is positioned above ring B and N9 above ring A, whereas in gutingimycin N1 is above ring B and O6 above ring A. The orientation of the sugars is almost identical in both structures since they are held in place by the same internal hydrogen bonds.

Table 2. Backbone and glycosyl torsion angles

Residue	Angle, degrees						
	α	β	γ	δ	ϵ	ζ	χ
A2 (next to intercalation)	282	176	60	155	254	280	209
A102	308	180	50	155	251	270	224
C3 (next to intercalation)	288	170	46	150	206	192	276
C103	287	157	52	147	218	188	274
C4	308	149	53	133	168	265	240
C104	298	139	56	134	183	238	242
G5	307	191	47	151	180	262	262
G105	311	181	48	149	181	268	259
G6 (next to intercalation)	293	183	51	144	238	264	273
G106	303	185	46	141	233	267	270
T7 (flipped-out)	302	159	61	147	251	82	252
T107	281	184	69	161	254	74	258
T8 (next to intercalation)	276	172	51	143	–	–	232
T108	236	184	81	130	–	–	221
B-DNA (range)	270–330	130–200	20–80	70–180	160–270	150–300	200–300
B-DNA (mean)	298	176 (I)	48	128 (I)	184 (I)	265 (I)	258 (A/G)
		146 (II)		144 (II)	246 (II)	174 (II)	241 (T/C)
							271 (II)

Torsion angles are defined as α : O3*-P-O5*-C5*, β : P-O5*-C5*-C4*, γ : O5*-C5*-C4*-C3*, δ : C5*-C4*-C3*-O3*, ϵ : C4*-C3*-O3*-P, ζ : C3*-O3*-P-O5*, χ (Purines): O4*-C1*-N9-C4, χ (Pyrimidines): O4*-C1*-N1-C2. For the mean values BI and BII conformations are distinguished, in the case of the glycosyl torsion angle χ also purines and pyrimidines for the BI conformation.

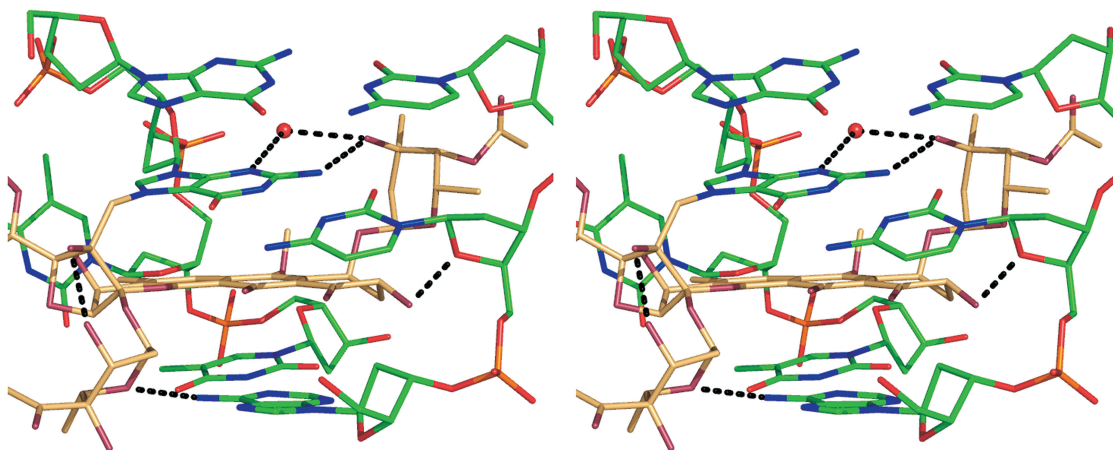

Figure 6. Stereoview of the DNA–trioxacarcin duplex. Base pair G(105)–C(4) is at the top, followed by base pair G(106)–C(3). Trioxacarcin A is bound to G(106) and intercalates on its 3'-side between base pair G(106)–C(3) and base pair T(108)–A(2), which is at the bottom. The carbon atoms of the trioxacarcin are shown in light orange. The flipped-out thymine is visible behind the trioxacarcin on the left. The red ball represents a water molecule. Hydrogen bonds are indicated with dashed lines.

One trioxacarcin is involved in stacking interactions with G(106) and A(2) (Figure 7A), the other with G(6) and A(102). Residues T(108) and T(8) interact slightly with the antibiotics but C(3) and C(103) do not. In the case of daunomycin or nogalamycin the long axis of the aglycone is nearly perpendicular to that of the base pairs (6,7), but this is not the case for trioxacarcin, which is constrained by the alkylation site. The aromatic rings A and B of the trioxacarcins lie below the atoms N9, N3 and C1' of residues G(106) and G(6). The long axis of the trioxacarcin aglycone is nearly parallel to that of the alkylated guanine (Figure 7A) and runs close to the sugar-phosphate backbone of this guanine. This orientation

brings the 10-methoxy groups of the trioxacarcins approximately into the positions where the deoxyriboses of residues T(107) and T(7) would lie if they were not flipped out. The flipped-out thymines are positioned near the 6-methyl groups of the trioxacarcins, the distance between C2 of T(7) and 6-methyl of trioxacarcin(9) is 3.3 Å [3.6 Å for the corresponding atoms of T(107) and trioxacarcin(109)].

Distortion of the DNA

The following analysis is based on standard nomenclature of nucleic acid structure parameters (20). The base pairs of

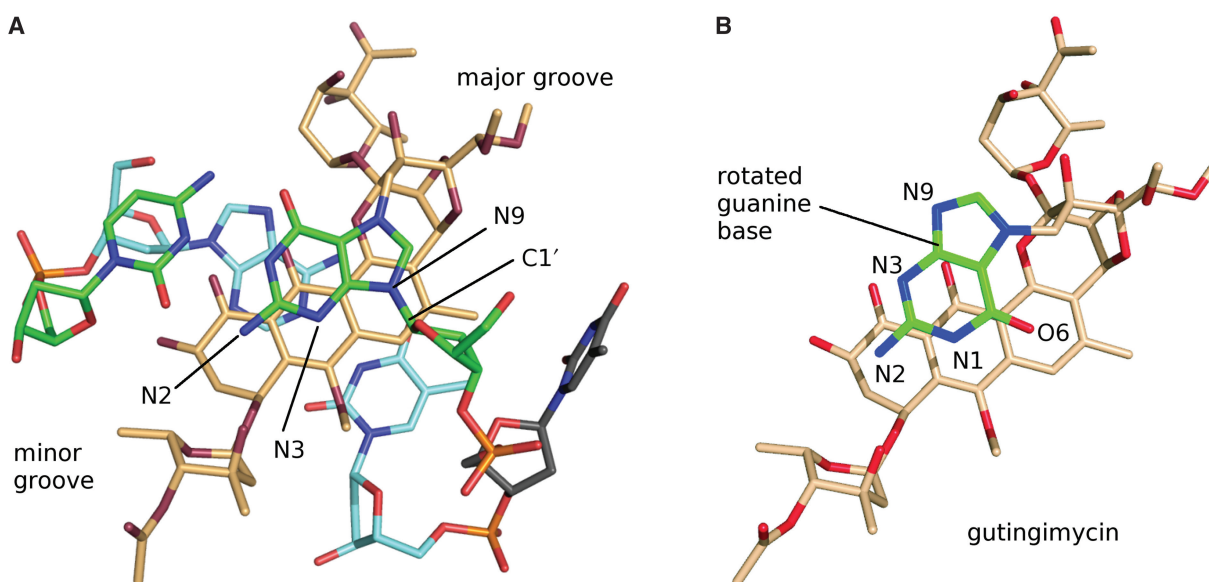

Figure 7. (A) View down the DNA helix axis. The carbon atoms of the upper base pair G(106)-C(3) are drawn in green, the ones of the lower base pair T(108)-A(2) in turquoise. The trioxacarcin is positioned between the two base pairs, with its carbon atoms colored in light orange. The carbon atoms of the flipped-out base T(107) are drawn in gray. (B) The small-molecule crystal structure of gutingimycin crystallized without DNA (5). The carbon atoms of the guanine base are drawn in green.

the DNA–trioxacarcin duplex are distorted in several different ways. At the intercalation site they are not planar; T(108)-A(2) is buckled by 9° and G(106)-C(3) by -10° [T(8)-A(102) by -6° and G(6)-C(103) by 13°]. This effect is well known for intercalators and explained by the need to maximize van der Waals contacts. The helical twist angles from base pair T(108)-A(2) to base pair A(102)-T(8) are 48° , 35° , 40° , 37° and 45° ; for B-DNA 37° is typical (20). Noncovalent intercalators such as daunomycin or nogalamycin usually unwind DNA (reducing these angles), whereas the intercalation of trioxacarcin combined with the flipping-out of a base in one of the two strands leads to an increased helical twist and an opening of the base pair (rotation of the bases relative to each other in the plane of the base-pair) for T(108)-A(2) of 10° [8° for T(8)-A(102)] towards the major groove. The angle between base pairs T(108)-A(2) and G(106)-C(3) (tilt) is -12° and opens towards the strand with the flipped-out thymine T(107) [corresponding values for T(8)-A(102)/G(6)-C(103)], also visible in Figure 6. Another distortion induced by the trioxacarcin is a displacement along the long axis of base pairs T(108)-A(2) and G(106)-C(3) (slide) by 2.0 \AA [2.2 \AA for T(8)-A(102)/G(6)-C(103)], also visible in Figure 7A. All these distortions are within the ranges observed for both complexed and uncomplexed double-stranded DNA structures.

Comparison with related DNA–antibiotic complexes

Structures of anthracyclines intercalated in DNA without the formation of covalent bonds invariably show the drug intercalated at the 5'-side of a guanine, usually between C and G or T and G. NMR studies of hedamycin–DNA (9,21,22), altromycin–DNA (10) and psorospermin–DNA (11) complexes, in which a covalent bond is formed by

nucleophilic attack of the guanine N7 on an epoxide as in trioxacarcin, showed a similar intercalation site to that observed for the anthracyclines, namely on the 5'-side of the alkylated guanine, without a flipped-out nucleobase. The crystal structure of trioxacarcin bound to d(AACC GGTT) reported here reveals a quite different intercalation on the 3'-side of guanine combined with a flipped-out thymine on the same side. This result is consistent with sequence selectivity studies (4) that report a preferred adduct formation with 5'-AATTTGTAATT or 5'-AATT AGTAATT compared to 5'-AATTTGAAATT or 5'-AATT TAGAAATT, showing that only a variation on the 3'-side of the alkylated guanine influences drug binding. In view of the evidence from the crystal structure that A(102) and A(2) pair with the thymine after the flipped-out thymine, we predict that trioxacarcin A should react preferentially with the DNA sequence 5'-GTT. In contrast, in the plauramycin and related complexes it is always the base on the 5'-side of the alkylated guanine that influences the sequence specificity, consistent with the observed intercalation site.

Since trioxacarcin A does not react with a guanine positioned at the 3'-terminus of a DNA-oligonucleotide (4), it appears that docking of the antibiotic, guided by the hydrogen bonds discussed above and the location of the bulky sugars in the minor and major grooves, with preliminary noncovalent binding to the DNA-helix is a prerequisite for the reaction of the trioxacarcin A with a guanine base. The detailed structure of this noncovalent complex before guanine attack is not yet known. It has to be taken into account that trioxacarcin A would have to thread into the DNA backbone, either by transient melting or by unwinding of the helix (7,23).

The flipping-out of bases plays an important role in certain DNA–protein interactions; for example in the

DNA repair enzyme uracil-DNA glycosylase (UDG) the discrimination between uracil and thymine is initiated by thermally induced opening of TA and UA base pairs (24). Base-pair dynamics may also be connected with the sequence selectivity of trioxacarcin A. An unresolved question is how streptomycetes protect their own DNA from the drug.

This study has revealed a unique structure for a DNA–drug complex that combines intercalation, alkylation and base flip-out. It provides insight into the mechanism of the formation of gutingimycin with the abstraction of a guanine base from DNA and adds to our understanding of DNA manipulation by antibiotics.

ACKNOWLEDGEMENTS

We thank Uwe Müller and all personnel of beam-line 14.2 of BESSY (Berlin) for assistance with the data collections. We are grateful to the Deutsche Forschungsgemeinschaft (grant Sh 14/5) and to the Fonds der Chemischen Industrie for support and funding to pay the Open Access publication charges for this article.

Conflict of interest statement. None declared.

REFERENCES

- Tomita, F., Tamaoki, T., Morimoto, M. and Fujimoto, K. (1981) Trioxacarcins, novel antitumor antibiotics. I. Producing organism, fermentation and biological activities. *J. Antibiot.*, **34**, 1519–1524.
- Tamaoki, T., Shirahata, K., Iida, T. and Tomita, F. (1981) Trioxacarcins, novel antitumor antibiotics. II. Isolation, physico-chemical properties and modes of action. *J. Antibiot.*, **34**, 1525–1530.
- Maskey, R.P., Helmke, E., Kayser, O., Fiebig, H.H., Maier, A., Busche, A. and Laatsch, H. (2004) Anti-cancer and antibacterial trioxacarcins with high anti-malaria activity from a marine Streptomycete and their absolute stereochemistry. *J. Antibiot.*, **57**, 771–779.
- Fitzner, A., Frauendorf, H., Laatsch, H. and Diederichsen, U. (2008) Formation of gutingimycin: analytical investigations of trioxacarcin A mediated alkylation of dsDNA. *Anal. Bioanal. Chem.*, **390**, 1139–1147.
- Maskey, R.P., Sevana, M., Usón, I., Helmke, E. and Laatsch, H. (2004) Gutingimycin: a highly complex metabolite from a marine streptomycete. *Angew. Chem. Int. Ed.*, **43**, 1281–1383.
- Wang, A.H.-J., Ughetto, G., Quigley, G.J. and Rich, A. (1987) Interactions between an anthracycline antibiotic and DNA: molecular structure of daunomycin complexed to d(CpGpTpApCpG) at 1.2 Å resolution. *Biochemistry*, **26**, 1152–1163.
- Williams, L.D., Egli, M., Gao, Q., Bash, P., Marel, G.A., Boom, J.H., Rich, A. and Frederick, C.A. (1990) Structure of nogalamycin bound to a DNA hexamer. *Proc. Natl Acad. Sci. USA*, **87**, 2225–2229.
- Hansen, M.R. and Hurley, L.H. (1996) Pluramycins, old drugs having modern friends in structural biology. *Acc. Chem. Res.*, **29**, 249–258.
- Hansen, M., Yun, S. and Hurley, L.H. (1995) Hedamycin intercalates the DNA helix and, through carbohydrate-mediated recognition in the minor groove, directs N7-alkylation of guanine in the major groove in a sequence-specific manner. *Chem. Biol.*, **2**, 229–240.
- Sun, D., Hansen, M., Clement, J.J. and Hurley, L.H. (1993) Structure of the altromycin B (N7-guanine)-DNA adduct. A proposed prototypic DNA adduct structure for the pluramycin antitumor antibiotics. *Biochemistry*, **32**, 8068–8074.
- Hansen, M., Lee, S.-J., Cassidy, J.M. and Hurley, L.H. (1996) Molecular details of the structure of a psorospermin-DNA covalent/intercalation complex and associated DNA sequence selectivity. *J. Am. Chem. Soc.*, **118**, 5553–5561.
- Maskey, R.P., Helmke, E. and Laatsch, H. (2002) Parimycin: isolation and structure elucidation of a novel cytotoxic 2,3-dihydroquinazolin analogue of γ -indomycinone from a marine streptomycete isolate. *J. Antibiot.*, **55**, 1031–1035.
- Otwinowski, Z. and Minor, W. (1997) Processing of X-ray diffraction data collected in oscillation mode. *Methods Enzymol.*, **276**, 307–326.
- Schneider, T.R. and Sheldrick, G.M. (2002) Substructure solution with SHELXD. *Acta Crystallogr.*, **D58**, 1772–1779.
- Sheldrick, G.M. (2002) Macromolecular phasing with SHELXE. *Z. Kristallogr.*, **217**, 644–650.
- Emsley, P. and Cowtan, K. (2004) Coot: model building tools for molecular graphics. *Acta Crystallogr.*, **D60**, 2126–2132.
- Murshudov, G.N., Vagin, A.A. and Dodson, E.J. (1997) Refinement of macromolecular structures by the maximum-likelihood method. *Acta Crystallogr.*, **D53**, 240–255.
- Lu, X.-J. and Olson, W.K. (2003) 3DNA: a software package for the analysis, rebuilding and visualization of three-dimensional nucleic acid structures. *Nucleic Acids Res.*, **31**, 5108–5121.
- Schneider, B., Neidle, S. and Berman, H.M. (1997) Conformations of the sugar-phosphate backbone in helical DNA crystal structures. *Biopolymers*, **42**, 113–124.
- Olson, W.K., Bansal, M., Burley, S.K., Dickerson, R.E., Gerstein, M., Harvey, S.C., Heinemann, U., Lu, X.-J., Neidle, S., Shakked, Z. et al. (2001) A standard reference frame for the description of nucleic acid base-pair geometry. *J. Mol. Biol.*, **313**, 229–237.
- Pavlopoulos, S., Bicknell, W., Craik, D.J. and Wickham, G. (1996) Structural characterization of the 1:1 adduct formed between the antitumor antibiotic hedamycin and the oligonucleotide duplex d(CACGTG)₂ by 2D NMR spectroscopy. *Biochemistry*, **35**, 9314–9324.
- Owen, E.A., Burley, G.A., Carver, J.A., Wickham, G. and Keniry, M.A. (2002) Structural investigation of the hedamycin d(ACCGGT) complex by NMR and restrained molecular dynamics. *Biochem. Biophys. Res. Comm.*, **290**, 1602–1608.
- Collier, D.A., Neidle, S. and Brown, J.R. (1984) Molecular models for the interaction of the anti-tumor drug nogalamycin with DNA. *Biochem. Pharmacol.*, **33**, 2877–2880.
- Parker, J.B., Bianchet, M.A., Krosky, D.J., Friedman, J.I., Amzel, L.M. and Stivers, J.T. (2007) Enzymatic capture of an extrahelical thymine in the search for uracil in DNA. *Nature*, **449**, 433–437.