

# Crystal structures of *fac*-tricarbonylchlorido(6,6'-dihydroxy-2,2'-bipyridine)rhenium(I) tetrahydrofuran monosolvate and *fac*-bromidotricarbonyl-(6,6'-dihydroxy-2,2'-bipyridine)manganese(I) tetrahydrofuran monosolvate

Sheri Lense,<sup>a\*</sup> Nicholas A. Piro,<sup>b</sup> Scott W. Kassel,<sup>b</sup> Andrew Wildish<sup>a</sup> and Brent Jeffery<sup>a</sup>

Received 28 June 2016  
Accepted 20 July 2016

Edited by H. Ishida, Okayama University, Japan

**Keywords:** crystal structure; 6,6'-dihydroxy-2,2'-bipyridine ligand; rhenium complex; manganese complex; hydrogen bonding; selective catalysts for CO<sub>2</sub> reduction.

**CCDC references:** 1495018; 1495017

**Supporting information:** this article has supporting information at journals.iucr.org/e

<sup>a</sup>University of Wisconsin Oshkosh, Department of Chemistry, 800 Algoma Blvd., Oshkosh, WI 54902, USA, and <sup>b</sup>Villanova University, Department of Chemistry, 800 E. Lancaster Avenue, Villanova, PA 19085, USA. \*Correspondence e-mail: lenses@uwosh.edu

The structures of two facially coordinated Group VII metal complexes, *fac*-[ReCl(C<sub>10</sub>H<sub>8</sub>N<sub>2</sub>O<sub>2</sub>)(CO)<sub>3</sub>]·C<sub>4</sub>H<sub>8</sub>O (I·THF) and *fac*-[MnBr(C<sub>10</sub>H<sub>8</sub>N<sub>2</sub>O<sub>2</sub>)(CO)<sub>3</sub>]·C<sub>4</sub>H<sub>8</sub>O (II·THF), are reported. In both complexes, the metal ion is coordinated by three carbonyl ligands, a halide ligand, and a 6,6'-dihydroxy-2,2'-bipyridine ligand in a distorted octahedral geometry. Both complexes co-crystallize with a non-coordinating tetrahydrofuran (THF) solvent molecule and exhibit intermolecular but not intramolecular hydrogen bonding. In both crystal structures, chains of complexes are formed due to intermolecular hydrogen bonding between a hydroxy group from the 6,6'-dihydroxy-2,2'-bipyridine ligand and the halide ligand from a neighboring complex. The THF molecule is hydrogen bonded to the remaining hydroxy group.

## 1. Chemical context

The *fac*-[Re( $\alpha$ -diimine)(CO)<sub>3</sub>X]<sup>n+</sup> and *fac*-[Mn( $\alpha$ -diimine)(CO)<sub>3</sub>X]<sup>n+</sup> (X = halide, n = 0 or X = neutral ligand, n = 1) family of complexes are of interest as selective catalysts for the reduction of CO<sub>2</sub> to CO (Bourrez *et al.*, 2011; Hawecker *et al.*, 1986; Smieja *et al.*, 2013; Sampson *et al.*, 2014; Machan *et al.*, 2014; Smieja & Kubiak, 2010). Utilizing substituted  $\alpha$ -diimine ligands in these complexes can optimize complexes sterically or electronically to catalyze the reduction of CO<sub>2</sub> to CO (Smieja & Kubiak, 2010; Sampson *et al.*, 2014) or facilitate formation of supramolecular assemblies that promote electrocatalytic reduction of CO<sub>2</sub> (Machan *et al.*, 2014). The addition of weak Brønsted acids such as water or methanol is necessary for the catalytic turnover of Mn complexes (Smieja *et al.*, 2013) and significantly increases the catalytic rate of Re complexes (Smieja *et al.*, 2012). Introducing intramolecular phenolic groups positioned near the metal atom has been shown to greatly increase the rate at which an iron tetraphenylporphyrin complex catalyzes the reduction of CO<sub>2</sub> to CO (Costentin *et al.*, 2012). Recently, the complexes *fac*-[Re(4,4'-dihydroxy-2,2'-bipyridine)(CO)<sub>3</sub>Cl] and *fac*-[Re(6,6'-dihydroxy-2,2'-bipyridine)(CO)<sub>3</sub>Cl] have been synthesized in order to study the effect of proton-responsive ligands in these catalysts and, for the latter complex, the effect of pendant acids positioned near the metal atom (Manbeck *et al.*, 2015). Unexpectedly, these complexes were found to exhibit reduc-

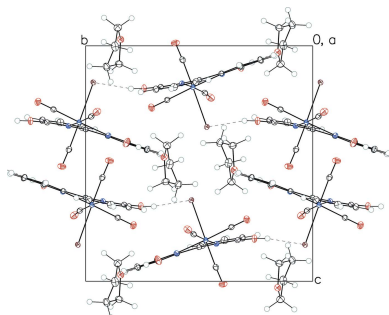

OPEN ACCESS

tive deprotonation of the hydroxy groups. While the crystal structure of *fac*-[Re(4,4'-dihydroxy-2,2'-bipyridine)(CO)<sub>3</sub>Cl] has been reported (Manbeck *et al.*, 2015), *fac*-[Re(6,6'-dihydroxy-2,2'-bipyridine)(CO)<sub>3</sub>Cl] has not been characterized crystallographically. In this paper we report the synthesis and structural characterization of *fac*-[Re(6,6'-dihydroxy-2,2'-bipyridine)(CO)<sub>3</sub>Cl] as well as the synthesis and structural characterization of the related and previously unknown complex, *fac*-[Mn(6,6'-dihydroxy-2,2'-bipyridine)(CO)<sub>3</sub>Br]. Both complexes co-crystallize with a tetrahydrofuran (THF) solvent molecule.

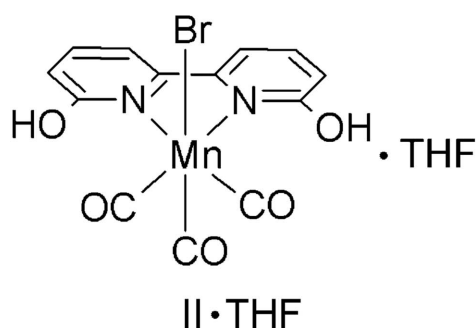
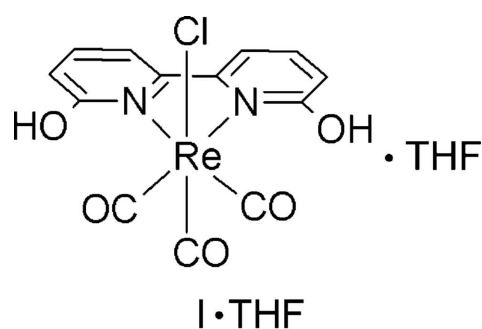

## 2. Structural commentary

Figs. 1 and 2 show ellipsoid plots of *fac*-[Re(6,6'-dihydroxy-2,2'-bipyridine)(CO)<sub>3</sub>Cl]·THF (I·THF) and [Mn(6,6'-dihydroxy-2,2'-bipyridine)(CO)<sub>3</sub>Br]·THF (II·THF), respectively.

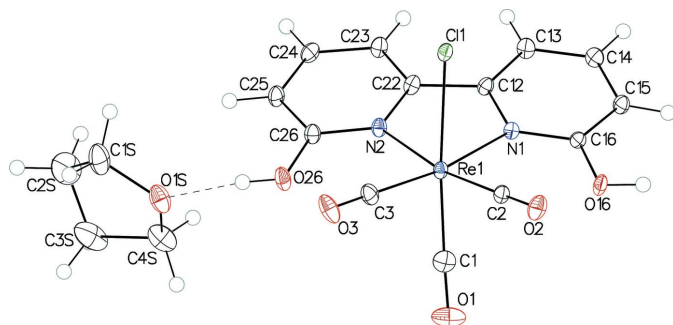

Figure 1

The molecular structure of I·THF, with 50% probability displacement ellipsoids for non-H atoms. The O—H...O hydrogen bond is shown by a dashed line. For the THF molecule, only one disordered component is shown.

Complexes I and II exhibit distorted octahedral geometries and contain primary coordination spheres similar to those of other *fac*-[Re( $\alpha$ -diimine)(CO)<sub>3</sub>Cl] and *fac*-[Mn( $\alpha$ -diimine)(CO)<sub>3</sub>Br] complexes, including [Re(bipyridine)(CO)<sub>3</sub>Cl] (III) (Manbeck *et al.*, 2015), [Re(4,4'-dihydroxy-2,2'-bipyridine)(CO)<sub>3</sub>Cl]·DMSO (IV) (Manbeck *et al.*, 2015) and [Mn(bipyridine)(CO)<sub>3</sub>I] (V) (Stor *et al.*, 1995). Many coordination modes are possible for the 2-hydroxypyridine ligand (Parsons & Winpenny, 1997), but the crystal structures confirm bidentate  $\alpha$ -diimine coordination in both complexes. Bond lengths between the metal and bipyridyl nitrogen atoms are slightly longer in I [2.198 (2) and 2.206 (2) Å] and II [2.0605 (11) and 2.0757 (11) Å] than in complexes III [2.176 (6) and 2.173 (6) Å], IV [2.177 (3) and 2.163 (3) Å] and V [2.05 (1) and 2.03 (2) Å], which do not have substituents in the 6 and 6' positions on the  $\alpha$ -diimine ligand. The longer bond lengths in I and II may be attributed to increased steric encumbrance due to these substituents. In both I and II, the distances between the oxygen atoms of the hydroxy substituents and the carbon atoms of the carbonyl ligands *cis* to the  $\alpha$ -diimine ligands fall within the sum of the van der Waals radii for carbon and oxygen (Batsanov, 2001). In I, the O(hydroxy)—C(carbonyl) distances are 2.800 (3) and 2.813 (4) Å and in II the O(hydroxy)—C(carbonyl) distances are 2.660 (2) and 2.615 (2) Å.

In I, the bipyridine rings present a bite angle of 74.09 (8)° to Re, similar to that found in III [74.41 (9)°] and IV [74.9 (2)°]. The bipyridine—Mn bite angle in II, 78.35 (4)°, is similar to that in V [79.0 (5)°]. The bipyridine ligands are not strictly planar. The dihedral angles between the pyridine rings are 11.68 (9)° in I and 9.49 (5)° in II. Additionally, the bipyridine ligands are not oriented strictly perpendicularly to the coordination planes of the metal ions. The dihedral angles between the mean plane through the  $\alpha$ -diimine ligands and the CO<sub>equatorial</sub>—M—CO<sub>equatorial</sub> planes are 23.51 (7) and 18.93 (3)° for the Re and Mn complexes, respectively. Neither I·THF nor II·THF exhibit intramolecular hydrogen bonding.

## 3. Supramolecular features

Hydrogen bonds for both structures are listed in Tables 1 and 2. In I·THF, a chain of complexes running along the *a* axis is formed by an O—H...Cl hydrogen bond between a hydroxy

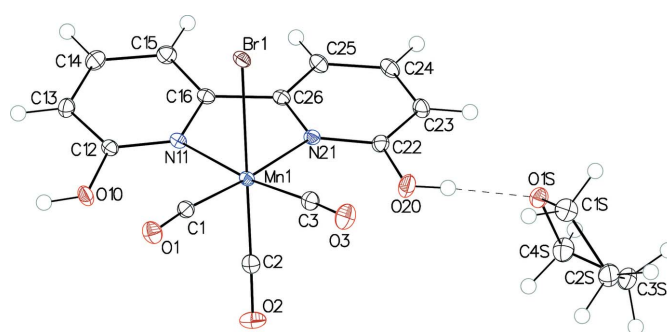
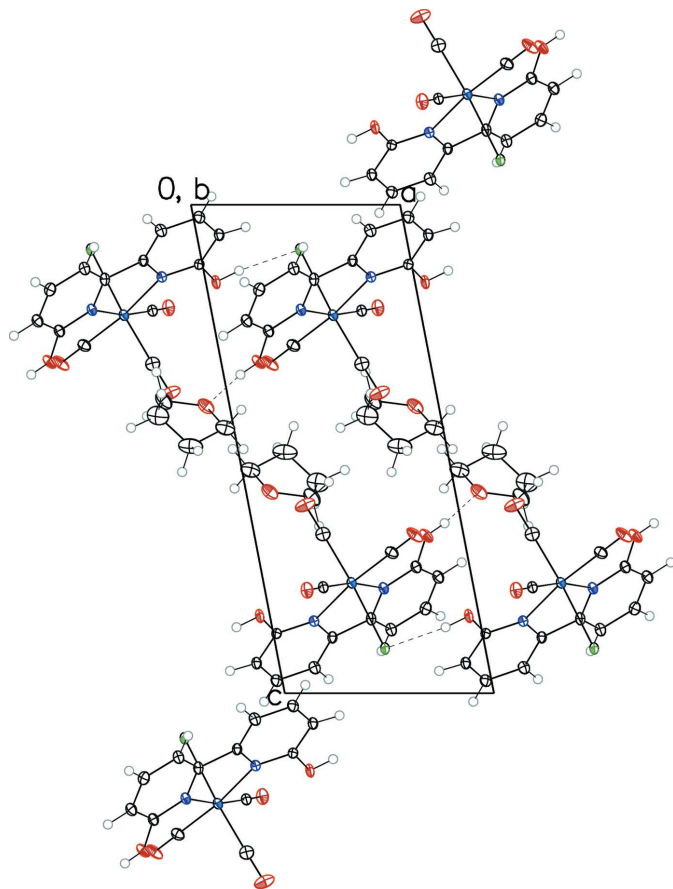

Figure 2

The molecular structure of II·THF, with 50% probability displacement ellipsoids for non-H atoms. The O—H...O hydrogen bond is shown by a dashed line.



**Figure 3**  
Crystal packing diagram of I·THF viewed along the *b* axis, showing hydrogen bonding (dashed lines) in the structure.

group (O16–H16) and the chloride ligand from the neighboring complex. The other hydroxy group (O26–H26) is hydrogen-bonded to the O atom of the THF molecule. The

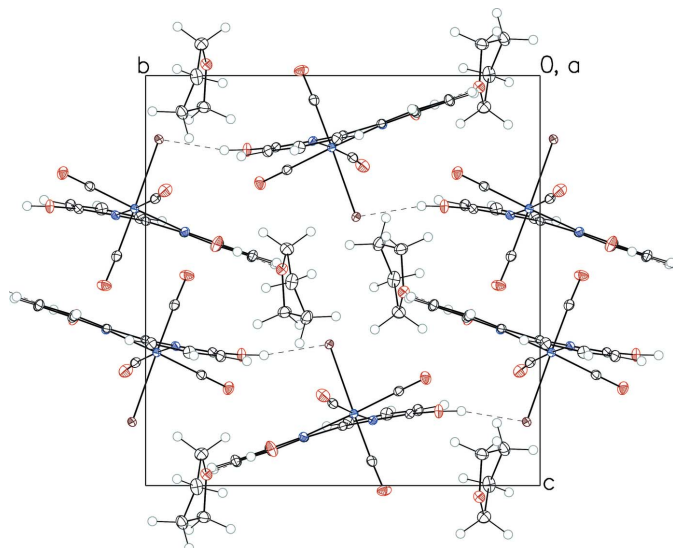

**Figure 4**  
Crystal packing diagram of II·THF viewed along the *a* axis, showing hydrogen bonding (dashed lines) in the structure.

**Table 1**  
Hydrogen-bond geometry (Å, °) for I·THF.

<i>D</i> –H··· <i>A</i>	<i>D</i> –H	H··· <i>A</i>	<i>D</i> ··· <i>A</i>	<i>D</i> –H··· <i>A</i>
O16–H16···Cl1 <sup>i</sup>	0.86 (4)	2.16 (4)	3.015 (2)	173 (3)
O26–H26···O1S	0.87 (4)	1.84 (4)	2.704 (3)	173 (4)

Symmetry code: (i)  $x - 1, y, z$ .

**Table 2**  
Hydrogen-bond geometry (Å, °) for II·THF.

<i>D</i> –H··· <i>A</i>	<i>D</i> –H	H··· <i>A</i>	<i>D</i> ··· <i>A</i>	<i>D</i> –H··· <i>A</i>
O10–H10···Br1 <sup>i</sup>	0.83 (2)	2.39 (2)	3.2098 (10)	170 (2)
O20–H20···O1S	0.80 (2)	1.79 (2)	2.5903 (15)	176 (2)

Symmetry code: (i)  $-x + 1, y + \frac{1}{2}, -z + \frac{1}{2}$ .

nearest pyridine rings between neighboring complexes have centroid–centroid distances of 3.9448 (16) Å, longer than the maximum distance typically given for  $\pi$ – $\pi$  interactions (Janiak, 2000). In II·THF, a chain of complexes is formed along the *b* axis through an O–H···Br hydrogen bond involving the O10–H10 group and the bromide ligand of the adjacent molecule, whereas the other hydroxy group (O20–H20) is hydrogen-bonded to O1S of the solvent THF molecule. There are weak  $\pi$ – $\pi$  stacking interactions between pairs of

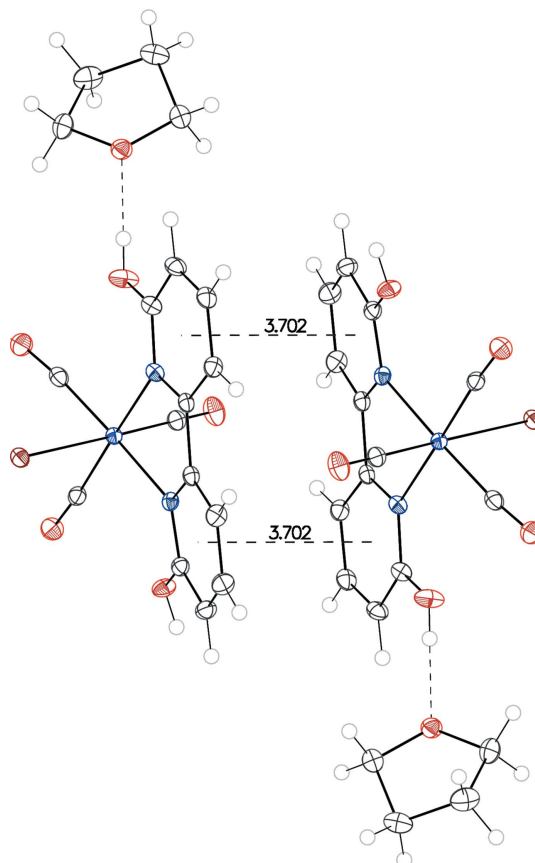

**Figure 5**  
Illustration of  $\pi$ – $\pi$  stacking interactions and O–H···O hydrogen bonds (dashed lines) in II·THF.

**Table 3**  
Experimental details.

	I·THF	II·THF
Crystal data		
Chemical formula	[ReCl(C <sub>10</sub> H <sub>8</sub> N <sub>2</sub> O <sub>2</sub> )(CO) <sub>3</sub> ] <sub>2</sub> ·C <sub>4</sub> H <sub>8</sub> O	[MnBr(C <sub>10</sub> H <sub>8</sub> N <sub>2</sub> O <sub>2</sub> )(CO) <sub>3</sub> ] <sub>2</sub> ·C <sub>4</sub> H <sub>8</sub> O
<i>M<sub>r</sub></i>	565.97	479.17
Crystal system, space group	Triclinic, <i>P</i> $\bar{1}$	Monoclinic, <i>P</i> 2 <sub>1</sub> / <i>c</i>
Temperature (K)	100	100
<i>a</i> , <i>b</i> , <i>c</i> (Å)	6.9661 (6), 8.0082 (6), 16.9007 (13)	10.2401 (12), 13.1783 (15), 14.2480 (16)
$\alpha$ , $\beta$ , $\gamma$ (°)	78.907 (2), 79.128 (2), 88.886 (2)	90, 106.228 (3), 90
<i>V</i> (Å <sup>3</sup> )	908.46 (13)	1846.1 (4)
<i>Z</i>	2	4
Radiation type	Mo <i>K</i> $\alpha$	Mo <i>K</i> $\alpha$
$\mu$ (mm <sup>-1</sup> )	6.87	2.92
Crystal size (mm)	0.20 × 0.10 × 0.01	0.36 × 0.13 × 0.08
Data collection		
Diffractometer	Bruker APEXII CCD	Bruker SMART APEX CCD area-detector
Absorption correction	Multi-scan ( <i>SADABS</i> ; Bruker, 2012)	Multi-scan ( <i>SADABS</i> ; Bruker, 2012)
<i>T</i> <sub>min</sub> , <i>T</i> <sub>max</sub>	0.583, 0.747	0.609, 0.747
No. of measured, independent and observed [ <i>I</i> > 2 $\sigma$ ( <i>I</i> )] reflections	37165, 8820, 7416	67915, 7363, 5841
<i>R</i> <sub>int</sub>	0.060	0.049
( <i>sin</i> $\theta$ / $\lambda$ ) <sub>max</sub> (Å <sup>-1</sup> )	0.833	0.781
Refinement		
<i>R</i> [ <i>F</i> <sup>2</sup> > 2 $\sigma$ ( <i>F</i> <sup>2</sup> )], <i>wR</i> ( <i>F</i> <sup>2</sup> ), <i>S</i>	0.033, 0.063, 1.01	0.027, 0.061, 1.01
No. of reflections	8820	7363
No. of parameters	260	252
No. of restraints	62	0
H-atom treatment	H atoms treated by a mixture of independent and constrained refinement	H atoms treated by a mixture of independent and constrained refinement
$\Delta\rho_{\max}$ , $\Delta\rho_{\min}$ (e Å <sup>-3</sup> )	1.71, -1.88	0.62, -0.45

Computer programs: *APEX2* (Bruker, 2014), *SAINT* (Bruker, 2013), *SHELXT* (Sheldrick, 2015a), *SHELXL2014* (Sheldrick, 2015b) and *OLEX2* (Dolomanov *et al.*, 2009).

complexes from neighboring chains. The centroid–centroid distance between pairs of pyridine rings is 3.7019 (9) Å and the angle between the ring normal and the vector between the ring centroids is 9.3°, within the parameters typically given for such  $\pi$ – $\pi$  interactions (Janiak, 2000). Packing diagrams are shown in Figs. 3, 4 and 5.

#### 4. Synthesis and crystallization

Methanol was degassed by sparging with N<sub>2</sub>. THF and diethyl ether were dried over molecular sieves and degassed using the freeze–pump–thaw method. MnBr(CO)<sub>5</sub> and ReCl(CO)<sub>5</sub> were purchased commercially and used as received. The ligand 6,6'-dihydroxy-2,2'-bipyridine was synthesized according to the synthetic procedure of Umemoto *et al.* (1998).

**I·THF:** 6,6'-dihydroxy-2,2'-bipyridine (249 mg, 1.32 mmol) and ReCl(CO)<sub>5</sub> (477 mg, 1.32 mmol) were heated at 333 K in 50 mL methanol under nitrogen for five h. The flask was covered with aluminum foil to keep out light. The reaction was then allowed to cool to room temperature and the solvent was removed under vacuum to give a yellow precipitate. Slow cooling of a hot THF solution of the complex in a glove box under a nitrogen atmosphere gave yellow plate-shaped crystals suitable for single crystal X-ray diffraction. Due to limited solubility of the complex in THF, this method could not be used for a bulk recrystallization of the complex.

**II·THF:** 6,6'-dihydroxy-2,2'-bipyridine (100 mg, 0.532 mmol) and MnBr(CO)<sub>5</sub> (146 mg, 0.532 mmol) were heated at 333 K in 24 mL methanol under nitrogen for five h. The flask was covered with aluminum foil to keep out light. The reaction was then allowed to cool to room temperature and the solvent was removed under vacuum to give an orange precipitate. The complex was recrystallized in bulk by layering pentane on a THF solution of the complex in a glove box under a nitrogen atmosphere at room temperature, giving the pure product in near quantitative yield. Slow diffusion of diethyl ether into a THF solution of the complex in a glove box under a nitrogen atmosphere gave yellow rod-shaped crystals suitable for single crystal X-ray diffraction.

#### 5. Refinement

Crystal data, data collection and structure refinement details are summarized in Table 3. For both complexes, the coordinates of H atoms forming hydrogen bonds (the hydroxy group hydrogens) were refined freely with *U*<sub>iso</sub>(H) = 1.5 *U*<sub>eq</sub>(O). C-bound H atoms were placed in calculated positions and refined with riding coordinates, with *U*<sub>iso</sub>(H) = 1.2 *U*<sub>eq</sub>(C). In I·THF, disorder occurs for one carbon and six hydrogens of the THF solvent with occupancies of 0.748 (11) and 0.252 (11). Rigid bond (*DELU*) and similar ADP (*SIMU*) restraints were used for atoms O1S, C1S, C2S, C3T, C3S and C4S.

## Acknowledgements

SL wishes to thank the American Chemical Society Petroleum Research Fund (PRF# 54833-UNI3) for the funding to perform this study.

## References

- Batsanov, S. S. (2001). *Inorg. Mater.* **37**, 871–885.
- Bourrez, M., Molton, F., Chardon-Noblat, S. & Deronzier, A. (2011). *Angew. Chem. Int. Ed.* **50**, 9903–9906.
- Bruker (2012). *SADABS*. Bruker AXS Inc., Madison, Wisconsin, USA.
- Bruker (2013). *SAINT*. Bruker AXS Inc., Madison, Wisconsin, USA.
- Bruker (2014). *APEX2*. Bruker AXS Inc., Madison, Wisconsin, USA.
- Costentin, C., Drouet, S., Robert, M. & Savéant, J. M. (2012). *Science*, **338**, 90–94.
- Dolomanov, O. V., Bourhis, L. J., Gildea, R. J., Howard, J. A. K. & Puschmann, H. (2009). *J. Appl. Cryst.* **42**, 339–341.
- Hawecker, J., Lehn, J.-M. & Ziessel, R. (1986). *Helv. Chim. Acta*, **69**, 1990–2012.
- Janiak, C. (2000). *J. Chem. Soc. Dalton Trans.* pp. 3885–3896.
- Machan, C. W., Chabolla, S. A., Yin, J., Gilson, M. K., Tezcan, F. A. & Kubiak, C. P. (2014). *J. Am. Chem. Soc.* **136**, 14598–14607.
- Manbeck, G. F., Muckerman, J. T., Szalda, D. J., Himeda, Y. & Fujita, E. (2015). *J. Phys. Chem. B*, **119**, 7457–7466.
- Parsons, S. & Winpenny, R. E. P. (1997). *Acc. Chem. Res.* **30**, 89–95.
- Sampson, M. D., Nguyen, A. D., Grice, K. A., Moore, C. E., Rheingold, A. L. & Kubiak, C. P. (2014). *J. Am. Chem. Soc.* **136**, 5460–5471.
- Sheldrick, G. M. (2015a). *Acta Cryst.* **A71**, 3–8.
- Sheldrick, G. M. (2015b). *Acta Cryst.* **C71**, 3–8.
- Smieja, J. M., Benson, E. E., Kumar, B., Grice, K. A., Seu, C. S., Miller, A. J. M., Mayer, J. M. & Kubiak, C. P. (2012). *Proc. Natl Acad. Sci. USA*, **109**, 15646–15650.
- Smieja, J. M. & Kubiak, C. P. (2010). *Inorg. Chem.* **49**, 9283–9289.
- Smieja, J. M., Sampson, M. D., Grice, K. A., Benson, E. E., Froehlich, J. D. & Kubiak, C. P. (2013). *Inorg. Chem.* **52**, 2484–2491.
- Stor, G. J., Stufkens, D. J., Vernooijs, P., Baerends, E. J., Fraanje, J. & Goubitz, K. (1995). *Inorg. Chem.* **34**, 1588–1594.
- Umamoto, T., Nagayoshi, M., Adachi, K. & Tomizawa, G. (1998). *J. Org. Chem.* **63**, 3379–3385.

## supporting information

*Acta Cryst.* (2016). E72, 1201-1205 [doi:10.1107/S2056989016011841]

## Crystal structures of *fac*-tricarbonylchlorido(6,6'-dihydroxy-2,2'-bipyridine)-rhenium(I) tetrahydrofuran monosolvate and *fac*-bromidotricarbonyl(6,6'-dihydroxy-2,2'-bipyridine)manganese(I) tetrahydrofuran monosolvate

Sheri Lense, Nicholas A. Piro, Scott W. Kassel, Andrew Wildish and Brent Jeffery

### Computing details

For both compounds, data collection: *APEX2* (Bruker, 2014); cell refinement: *SAINTE* (Bruker, 2013); data reduction: *SAINTE* (Bruker, 2013); program(s) used to solve structure: *SHELXT* (Sheldrick, 2015a); program(s) used to refine structure: *SHELXL2014* (Sheldrick, 2015b); molecular graphics: *OLEX2* (Dolomanov *et al.*, 2009); software used to prepare material for publication: *OLEX2* (Dolomanov *et al.*, 2009).

(Re\_complex) *fac*-Tricarbonylchlorido(6,6'-dihydroxy-2,2'-bipyridine)rhenium(I) tetrahydrofuran monosolvate

### Crystal data

[ReCl(C<sub>10</sub>H<sub>8</sub>N<sub>2</sub>O<sub>2</sub>)(CO)<sub>3</sub>]·C<sub>4</sub>H<sub>8</sub>O

*M<sub>r</sub>* = 565.97

Triclinic, *P* $\bar{1}$

*a* = 6.9661 (6) Å

*b* = 8.0082 (6) Å

*c* = 16.9007 (13) Å

$\alpha$  = 78.907 (2)°

$\beta$  = 79.128 (2)°

$\gamma$  = 88.886 (2)°

*V* = 908.46 (13) Å<sup>3</sup>

*Z* = 2

*F*(000) = 544

*D<sub>x</sub>* = 2.069 Mg m<sup>-3</sup>

Mo *K* $\alpha$  radiation,  $\lambda$  = 0.71073 Å

Cell parameters from 5671 reflections

$\theta$  = 2.5–32.4°

$\mu$  = 6.87 mm<sup>-1</sup>

*T* = 100 K

Plate, yellow

0.2 × 0.1 × 0.01 mm

### Data collection

Bruker APEXII CCD  
diffractometer

Radiation source: sealed tube

Graphite monochromator

Detector resolution: 8 pixels mm<sup>-1</sup>

$\omega$  and  $\varphi$  scans

Absorption correction: multi-scan  
(SADABS; Bruker, 2012)

*T<sub>min</sub>* = 0.583, *T<sub>max</sub>* = 0.747

37165 measured reflections

8820 independent reflections

7416 reflections with *I* > 2 $\sigma$ (*I*)

*R<sub>int</sub>* = 0.060

$\theta_{\max}$  = 36.3°,  $\theta_{\min}$  = 2.5°

*h* = -11→11

*k* = -13→13

*l* = -28→27

### Refinement

Refinement on *F*<sup>2</sup>

Least-squares matrix: full

*R* [*F*<sup>2</sup> > 2 $\sigma$ (*F*<sup>2</sup>)] = 0.033

*wR*(*F*<sup>2</sup>) = 0.063

*S* = 1.01

8820 reflections

260 parameters

62 restraints

Primary atom site location: structure-invariant  
direct methods

Hydrogen site location: mixed



H atoms treated by a mixture of independent  
and constrained refinement  
 $w = 1/[\sigma^2(F_o^2) + (0.0215P)^2]$   
where  $P = (F_o^2 + 2F_c^2)/3$

$$(\Delta/\sigma)_{\max} = 0.003$$

$$\Delta\rho_{\max} = 1.71 \text{ e } \text{\AA}^{-3}$$

$$\Delta\rho_{\min} = -1.88 \text{ e } \text{\AA}^{-3}$$

#### Special details

**Geometry.** All esds (except the esd in the dihedral angle between two l.s. planes) are estimated using the full covariance matrix. The cell esds are taken into account individually in the estimation of esds in distances, angles and torsion angles; correlations between esds in cell parameters are only used when they are defined by crystal symmetry. An approximate (isotropic) treatment of cell esds is used for estimating esds involving l.s. planes.

#### Fractional atomic coordinates and isotropic or equivalent isotropic displacement parameters ( $\text{\AA}^2$ )

	<i>x</i>	<i>y</i>	<i>z</i>	$U_{\text{iso}}^*/U_{\text{eq}}$	Occ. (<1)
Re1	0.42194 (2)	0.68445 (2)	0.77393 (2)	0.01301 (3)	
Cl1	0.52023 (8)	0.69909 (8)	0.90827 (4)	0.01477 (11)	
O16	-0.0490 (3)	0.6754 (3)	0.84174 (13)	0.0186 (4)	
H16	-0.170 (5)	0.680 (5)	0.865 (2)	0.028*	
O2	0.2010 (3)	1.0152 (3)	0.78896 (14)	0.0241 (5)	
N1	0.2057 (3)	0.4977 (3)	0.85218 (14)	0.0133 (4)	
O1S	1.1132 (3)	0.3754 (3)	0.58779 (15)	0.0292 (5)	
O1	0.2709 (4)	0.7047 (3)	0.61441 (15)	0.0359 (6)	
O26	0.8204 (3)	0.5231 (3)	0.67795 (14)	0.0225 (4)	
H26	0.920 (6)	0.477 (5)	0.652 (2)	0.034*	
N2	0.5697 (3)	0.4372 (3)	0.78476 (14)	0.0144 (4)	
O3	0.7668 (3)	0.9154 (3)	0.67574 (15)	0.0294 (5)	
C3	0.6398 (4)	0.8253 (4)	0.71185 (18)	0.0202 (5)	
C1	0.3292 (5)	0.6881 (4)	0.6741 (2)	0.0228 (6)	
C12	0.2792 (4)	0.3466 (3)	0.88559 (17)	0.0144 (5)	
C24	0.7513 (4)	0.1272 (4)	0.82643 (18)	0.0189 (5)	
H24	0.8148	0.0231	0.8415	0.023*	
C26	0.7446 (4)	0.4026 (3)	0.74160 (17)	0.0163 (5)	
C23	0.5671 (4)	0.1572 (3)	0.86943 (18)	0.0171 (5)	
H23	0.5019	0.0728	0.9132	0.021*	
C16	0.0154 (4)	0.5269 (3)	0.87765 (16)	0.0143 (5)	
C25	0.8405 (4)	0.2491 (4)	0.76204 (18)	0.0184 (5)	
H25	0.9656	0.2298	0.7317	0.022*	
C2	0.2812 (4)	0.8889 (3)	0.78290 (17)	0.0157 (5)	
C22	0.4806 (4)	0.3117 (3)	0.84742 (17)	0.0149 (5)	
C13	0.1667 (4)	0.2300 (3)	0.94723 (18)	0.0178 (5)	
H13	0.2222	0.1274	0.9708	0.021*	
C15	-0.1072 (4)	0.4124 (3)	0.93829 (17)	0.0166 (5)	
H15	-0.2416	0.4359	0.9543	0.020*	
C14	-0.0279 (4)	0.2646 (3)	0.97415 (18)	0.0175 (5)	
H14	-0.1061	0.1868	1.0171	0.021*	
C1S	1.3097 (5)	0.3276 (5)	0.5990 (2)	0.0357 (8)	
H1SA	1.3186	0.3115	0.6577	0.043*	
H1SB	1.4051	0.4173	0.5674	0.043*	
C2S	1.3515 (7)	0.1634 (5)	0.5683 (3)	0.0506 (11)	

H2SA	1.4910	0.1565	0.5431	0.061*	0.748 (11)
H2SB	1.3147	0.0633	0.6130	0.061*	0.748 (11)
H2SC	1.4472	0.1839	0.5160	0.061*	0.252 (11)
H2SD	1.4068	0.0800	0.6090	0.061*	0.252 (11)
C4S	1.0405 (6)	0.2609 (5)	0.5432 (2)	0.0359 (8)	
H4SA	0.9741	0.3242	0.5000	0.043*	0.748 (11)
H4SB	0.9482	0.1754	0.5806	0.043*	0.748 (11)
H4SC	1.0571	0.3126	0.4841	0.043*	0.252 (11)
H4SD	0.9001	0.2342	0.5649	0.043*	0.252 (11)
C3S	1.2233 (10)	0.1777 (7)	0.5060 (4)	0.0479 (17)	0.748 (11)
H3SA	1.1924	0.0640	0.4964	0.057*	0.748 (11)
H3SB	1.2870	0.2487	0.4533	0.057*	0.748 (11)
C3T	1.164 (2)	0.0969 (18)	0.5559 (11)	0.039 (4)	0.252 (11)
H3TA	1.1015	0.0133	0.6046	0.047*	0.252 (11)
H3TB	1.1842	0.0430	0.5070	0.047*	0.252 (11)

*Atomic displacement parameters (Å<sup>2</sup>)*

	$U^{11}$	$U^{22}$	$U^{33}$	$U^{12}$	$U^{13}$	$U^{23}$
Re1	0.01156 (4)	0.01031 (5)	0.01605 (5)	0.00098 (3)	-0.00087 (3)	-0.00155 (3)
Cl1	0.0108 (2)	0.0149 (3)	0.0182 (3)	0.00042 (19)	-0.0026 (2)	-0.0021 (2)
O16	0.0089 (8)	0.0184 (10)	0.0256 (11)	0.0010 (7)	-0.0010 (7)	0.0009 (8)
O2	0.0207 (10)	0.0160 (10)	0.0356 (13)	0.0065 (8)	-0.0050 (9)	-0.0062 (9)
N1	0.0126 (9)	0.0123 (10)	0.0151 (10)	0.0001 (7)	-0.0021 (8)	-0.0033 (8)
O1S	0.0317 (12)	0.0209 (11)	0.0313 (13)	-0.0011 (9)	0.0069 (10)	-0.0085 (9)
O1	0.0600 (18)	0.0264 (13)	0.0262 (13)	-0.0014 (11)	-0.0207 (12)	-0.0042 (10)
O26	0.0205 (10)	0.0160 (10)	0.0242 (11)	0.0053 (7)	0.0071 (8)	0.0014 (8)
N2	0.0122 (9)	0.0123 (10)	0.0180 (11)	-0.0003 (7)	-0.0007 (8)	-0.0030 (8)
O3	0.0298 (12)	0.0213 (11)	0.0291 (13)	-0.0128 (9)	0.0121 (10)	-0.0015 (9)
C3	0.0216 (12)	0.0176 (13)	0.0199 (14)	0.0038 (10)	0.0010 (10)	-0.0050 (10)
C1	0.0285 (15)	0.0139 (13)	0.0257 (15)	0.0011 (10)	-0.0056 (12)	-0.0028 (11)
C12	0.0122 (10)	0.0122 (11)	0.0183 (12)	-0.0001 (8)	-0.0033 (9)	-0.0016 (9)
C24	0.0192 (12)	0.0142 (12)	0.0242 (14)	0.0058 (9)	-0.0063 (11)	-0.0041 (10)
C26	0.0145 (11)	0.0140 (12)	0.0197 (13)	0.0007 (9)	-0.0010 (9)	-0.0035 (10)
C23	0.0150 (11)	0.0118 (11)	0.0230 (14)	0.0006 (9)	-0.0016 (10)	-0.0015 (10)
C16	0.0130 (10)	0.0158 (12)	0.0145 (12)	-0.0003 (8)	-0.0029 (9)	-0.0032 (9)
C25	0.0162 (11)	0.0160 (12)	0.0221 (14)	0.0045 (9)	-0.0006 (10)	-0.0046 (10)
C2	0.0129 (10)	0.0158 (12)	0.0177 (12)	0.0002 (9)	-0.0021 (9)	-0.0025 (10)
C22	0.0125 (10)	0.0105 (11)	0.0220 (13)	-0.0012 (8)	-0.0035 (9)	-0.0033 (9)
C13	0.0173 (12)	0.0116 (11)	0.0225 (14)	-0.0013 (9)	-0.0013 (10)	-0.0006 (10)
C15	0.0128 (11)	0.0173 (12)	0.0192 (13)	-0.0022 (9)	-0.0025 (9)	-0.0029 (10)
C14	0.0168 (11)	0.0144 (12)	0.0200 (13)	-0.0041 (9)	-0.0020 (10)	-0.0008 (10)
C1S	0.0332 (17)	0.0256 (17)	0.043 (2)	0.0059 (13)	0.0074 (15)	-0.0073 (15)
C2S	0.067 (3)	0.033 (2)	0.050 (3)	0.021 (2)	-0.004 (2)	-0.0118 (19)
C4S	0.049 (2)	0.0251 (17)	0.0300 (18)	-0.0054 (15)	0.0007 (16)	-0.0050 (14)
C3S	0.083 (4)	0.027 (3)	0.031 (3)	0.016 (3)	-0.001 (3)	-0.010 (2)
C3T	0.054 (7)	0.018 (6)	0.038 (9)	0.002 (5)	0.015 (6)	-0.009 (6)



*Geometric parameters (Å, °)*

Re1—C11	2.5159 (7)	C16—C15	1.400 (4)
Re1—N1	2.198 (2)	C25—H25	0.9500
Re1—N2	2.206 (2)	C13—H13	0.9500
Re1—C3	1.920 (3)	C13—C14	1.386 (4)
Re1—C1	1.912 (3)	C15—H15	0.9500
Re1—C2	1.908 (3)	C15—C14	1.378 (4)
O16—H16	0.86 (4)	C14—H14	0.9500
O16—C16	1.337 (3)	C1S—H1SA	0.9900
O2—C2	1.158 (3)	C1S—H1SB	0.9900
N1—C12	1.366 (3)	C1S—C2S	1.507 (5)
N1—C16	1.344 (3)	C2S—H2SA	0.9900
O1S—C1S	1.451 (4)	C2S—H2SB	0.9900
O1S—C4S	1.447 (4)	C2S—H2SC	0.9900
O1—C1	1.140 (4)	C2S—H2SD	0.9900
O26—H26	0.87 (4)	C2S—C3S	1.491 (8)
O26—C26	1.332 (3)	C2S—C3T	1.484 (18)
N2—C26	1.350 (3)	C4S—H4SA	0.9900
N2—C22	1.372 (3)	C4S—H4SB	0.9900
O3—C3	1.152 (4)	C4S—H4SC	0.9900
C12—C22	1.475 (3)	C4S—H4SD	0.9900
C12—C13	1.385 (4)	C4S—C3S	1.512 (7)
C24—H24	0.9500	C4S—C3T	1.559 (15)
C24—C23	1.391 (4)	C3S—H3SA	0.9900
C24—C25	1.372 (4)	C3S—H3SB	0.9900
C26—C25	1.403 (4)	C3T—H3TA	0.9900
C23—H23	0.9500	C3T—H3TB	0.9900
C23—C22	1.383 (4)		
N1—Re1—C11	82.99 (6)	C14—C13—H13	120.4
N1—Re1—N2	74.09 (8)	C16—C15—H15	120.9
N2—Re1—C11	85.17 (6)	C14—C15—C16	118.3 (2)
C3—Re1—C11	92.47 (9)	C14—C15—H15	120.9
C3—Re1—N1	171.39 (10)	C13—C14—H14	120.2
C3—Re1—N2	98.30 (10)	C15—C14—C13	119.7 (3)
C1—Re1—C11	174.77 (9)	C15—C14—H14	120.2
C1—Re1—N1	96.46 (11)	O1S—C1S—H1SA	110.3
C1—Re1—N2	99.71 (11)	O1S—C1S—H1SB	110.3
C1—Re1—C3	88.72 (13)	O1S—C1S—C2S	106.9 (3)
C2—Re1—C11	87.58 (8)	H1SA—C1S—H1SB	108.6
C2—Re1—N1	99.67 (10)	C2S—C1S—H1SA	110.3
C2—Re1—N2	170.95 (10)	C2S—C1S—H1SB	110.3
C2—Re1—C3	87.40 (11)	C1S—C2S—H2SA	111.5
C2—Re1—C1	87.38 (12)	C1S—C2S—H2SB	111.5
C16—O16—H16	106 (2)	C1S—C2S—H2SC	110.2
C12—N1—Re1	115.69 (16)	C1S—C2S—H2SD	110.2
C16—N1—Re1	125.85 (17)	H2SA—C2S—H2SB	109.3

C16—N1—C12	117.9 (2)	H2SC—C2S—H2SD	108.5
C4S—O1S—C1S	109.3 (3)	C3S—C2S—C1S	101.4 (3)
C26—O26—H26	105 (3)	C3S—C2S—H2SA	111.5
C26—N2—Re1	126.82 (18)	C3S—C2S—H2SB	111.5
C26—N2—C22	117.6 (2)	C3T—C2S—C1S	107.7 (6)
C22—N2—Re1	115.29 (16)	C3T—C2S—H2SC	110.2
O3—C3—Re1	177.2 (3)	C3T—C2S—H2SD	110.2
O1—C1—Re1	174.1 (3)	O1S—C4S—H4SA	111.1
N1—C12—C22	115.4 (2)	O1S—C4S—H4SB	111.1
N1—C12—C13	121.9 (2)	O1S—C4S—H4SC	110.6
C13—C12—C22	122.6 (2)	O1S—C4S—H4SD	110.6
C23—C24—H24	120.2	O1S—C4S—C3S	103.5 (4)
C25—C24—H24	120.2	O1S—C4S—C3T	105.8 (7)
C25—C24—C23	119.5 (2)	H4SA—C4S—H4SB	109.0
O26—C26—N2	115.8 (2)	H4SC—C4S—H4SD	108.7
O26—C26—C25	121.9 (2)	C3S—C4S—H4SA	111.1
N2—C26—C25	122.3 (2)	C3S—C4S—H4SB	111.1
C24—C23—H23	120.5	C3T—C4S—H4SC	110.6
C22—C23—C24	118.9 (3)	C3T—C4S—H4SD	110.6
C22—C23—H23	120.5	C2S—C3S—C4S	104.5 (4)
O16—C16—N1	115.2 (2)	C2S—C3S—H3SA	110.9
O16—C16—C15	121.9 (2)	C2S—C3S—H3SB	110.9
N1—C16—C15	122.9 (2)	C4S—C3S—H3SA	110.9
C24—C25—C26	119.1 (2)	C4S—C3S—H3SB	110.9
C24—C25—H25	120.4	H3SA—C3S—H3SB	108.9
C26—C25—H25	120.4	C2S—C3T—C4S	102.5 (9)
O2—C2—Re1	177.8 (2)	C2S—C3T—H3TA	111.3
N2—C22—C12	115.6 (2)	C2S—C3T—H3TB	111.3
N2—C22—C23	122.5 (2)	C4S—C3T—H3TA	111.3
C23—C22—C12	121.8 (2)	C4S—C3T—H3TB	111.3
C12—C13—H13	120.4	H3TA—C3T—H3TB	109.2
C12—C13—C14	119.2 (2)		
Re1—N1—C12—C22	-16.1 (3)	C12—C13—C14—C15	1.2 (4)
Re1—N1—C12—C13	168.2 (2)	C24—C23—C22—N2	-0.1 (4)
Re1—N1—C16—O16	10.2 (3)	C24—C23—C22—C12	174.8 (3)
Re1—N1—C16—C15	-168.8 (2)	C26—N2—C22—C12	-172.3 (2)
Re1—N2—C26—O26	-10.9 (4)	C26—N2—C22—C23	2.9 (4)
Re1—N2—C26—C25	169.5 (2)	C23—C24—C25—C26	0.8 (4)
Re1—N2—C22—C12	13.6 (3)	C16—N1—C12—C22	172.0 (2)
Re1—N2—C22—C23	-171.2 (2)	C16—N1—C12—C13	-3.7 (4)
O16—C16—C15—C14	-177.9 (3)	C16—C15—C14—C13	-2.7 (4)
N1—C12—C22—N2	1.6 (4)	C25—C24—C23—C22	-1.7 (4)
N1—C12—C22—C23	-173.7 (3)	C22—N2—C26—O26	175.7 (2)
N1—C12—C13—C14	2.1 (4)	C22—N2—C26—C25	-3.9 (4)
N1—C16—C15—C14	1.0 (4)	C22—C12—C13—C14	-173.4 (3)
O1S—C1S—C2S—C3S	27.5 (5)	C13—C12—C22—N2	177.3 (3)
O1S—C1S—C2S—C3T	-11.9 (8)	C13—C12—C22—C23	2.0 (4)

O1S—C4S—C3S—C2S	34.3 (5)	C1S—O1S—C4S—C3S	-16.8 (4)
O1S—C4S—C3T—C2S	-28.0 (10)	C1S—O1S—C4S—C3T	21.7 (7)
O26—C26—C25—C24	-177.5 (3)	C1S—C2S—C3S—C4S	-37.6 (5)
N2—C26—C25—C24	2.2 (4)	C1S—C2S—C3T—C4S	24.0 (11)
C12—N1—C16—O16	-178.8 (2)	C4S—O1S—C1S—C2S	-6.7 (4)
C12—N1—C16—C15	2.2 (4)		

*Hydrogen-bond geometry* ( $\text{\AA}$ ,  $^\circ$ )

$D-H\cdots A$	$D-H$	$H\cdots A$	$D\cdots A$	$D-H\cdots A$
O16—H16 $\cdots$ C11 <sup>i</sup>	0.86 (4)	2.16 (4)	3.015 (2)	173 (3)
O26—H26 $\cdots$ O1S	0.87 (4)	1.84 (4)	2.704 (3)	173 (4)

Symmetry code: (i)  $x-1, y, z$ .**(Mn\_complex) fac-Bromidotricarbonyl(6,6'-dihydroxy-2,2'-bipyridine)manganese(I) tetrahydrofuran monosolvate***Crystal data*[MnBr(C<sub>10</sub>H<sub>8</sub>N<sub>2</sub>O<sub>2</sub>)(CO)<sub>3</sub>] $\cdot$ C<sub>4</sub>H<sub>8</sub>O $M_r = 479.17$ Monoclinic,  $P2_1/c$  $a = 10.2401$  (12)  $\text{\AA}$  $b = 13.1783$  (15)  $\text{\AA}$  $c = 14.2480$  (16)  $\text{\AA}$  $\beta = 106.228$  (3) $^\circ$  $V = 1846.1$  (4)  $\text{\AA}^3$  $Z = 4$  $F(000) = 960$  $D_x = 1.724$  Mg m<sup>-3</sup>Mo  $K\alpha$  radiation,  $\lambda = 0.71073$   $\text{\AA}$ 

Cell parameters from 9928 reflections

 $\theta = 2.7-33.9^\circ$  $\mu = 2.92$  mm<sup>-1</sup> $T = 100$  K

Rod, yellow

 $0.36 \times 0.13 \times 0.08$  mm*Data collection*

Bruker SMART APEX CCD area-detector diffractometer

Radiation source: sealed tube

Graphite monochromator

Detector resolution: 8 pixels mm<sup>-1</sup> $\omega$  and  $\varphi$  scans

Absorption correction: multi-scan (SADABS; Bruker, 2012)

 $T_{\min} = 0.609$ ,  $T_{\max} = 0.747$ 

67915 measured reflections

7363 independent reflections

5841 reflections with  $I > 2\sigma(I)$  $R_{\text{int}} = 0.049$  $\theta_{\max} = 33.7^\circ$ ,  $\theta_{\min} = 2.1^\circ$  $h = -15 \rightarrow 15$  $k = -20 \rightarrow 20$  $l = -22 \rightarrow 22$ *Refinement*Refinement on  $F^2$ 

Least-squares matrix: full

 $R[F^2 > 2\sigma(F^2)] = 0.027$  $wR(F^2) = 0.061$  $S = 1.01$ 

7363 reflections

252 parameters

0 restraints

Hydrogen site location: mixed

H atoms treated by a mixture of independent and constrained refinement

 $w = 1/[\sigma^2(F_o^2) + (0.0253P)^2 + 0.8571P]$ where  $P = (F_o^2 + 2F_c^2)/3$  $(\Delta/\sigma)_{\max} = 0.001$  $\Delta\rho_{\max} = 0.62$  e  $\text{\AA}^{-3}$  $\Delta\rho_{\min} = -0.45$  e  $\text{\AA}^{-3}$

*Special details*

**Geometry.** All esds (except the esd in the dihedral angle between two l.s. planes) are estimated using the full covariance matrix. The cell esds are taken into account individually in the estimation of esds in distances, angles and torsion angles; correlations between esds in cell parameters are only used when they are defined by crystal symmetry. An approximate (isotropic) treatment of cell esds is used for estimating esds involving l.s. planes.

*Fractional atomic coordinates and isotropic or equivalent isotropic displacement parameters ( $\text{\AA}^2$ )*

	<i>x</i>	<i>y</i>	<i>z</i>	$U_{\text{iso}}^*/U_{\text{eq}}$
Br1	0.43600 (2)	0.46594 (2)	0.34466 (2)	0.01541 (4)
Mn1	0.30177 (2)	0.52808 (2)	0.17547 (2)	0.01092 (4)
O1	0.21509 (11)	0.71004 (8)	0.26247 (8)	0.0207 (2)
C1	0.25680 (14)	0.64158 (10)	0.23009 (10)	0.0145 (2)
O2	0.13075 (11)	0.60489 (9)	−0.01225 (8)	0.0236 (2)
C2	0.20034 (14)	0.57322 (10)	0.05953 (10)	0.0153 (2)
O3	0.05516 (11)	0.44992 (9)	0.21988 (8)	0.0239 (2)
C3	0.15176 (14)	0.47493 (10)	0.20007 (10)	0.0161 (2)
O10	0.45262 (10)	0.74298 (7)	0.18113 (8)	0.0179 (2)
H10	0.487 (2)	0.8003 (18)	0.1820 (17)	0.044 (6)*
N11	0.48726 (11)	0.57633 (8)	0.15938 (8)	0.01234 (19)
C12	0.54018 (14)	0.66975 (10)	0.17494 (9)	0.0138 (2)
C13	0.67743 (14)	0.69023 (11)	0.18420 (11)	0.0174 (3)
H13	0.7123	0.7572	0.1967	0.021*
C14	0.76061 (15)	0.61113 (11)	0.17475 (11)	0.0197 (3)
H14	0.8547	0.6225	0.1826	0.024*
C15	0.70589 (14)	0.51419 (11)	0.15355 (11)	0.0176 (3)
H15	0.7614	0.4590	0.1452	0.021*
C16	0.56946 (14)	0.49991 (10)	0.14487 (9)	0.0132 (2)
O20	0.16632 (11)	0.31944 (8)	0.08940 (9)	0.0237 (2)
H20	0.128 (2)	0.2669 (19)	0.0706 (18)	0.047 (7)*
N21	0.36778 (11)	0.40010 (8)	0.11925 (8)	0.01280 (19)
C22	0.29616 (14)	0.31508 (10)	0.08977 (10)	0.0153 (2)
C23	0.35367 (15)	0.22793 (10)	0.06115 (10)	0.0173 (3)
H23	0.3014	0.1678	0.0436	0.021*
C24	0.48671 (15)	0.23105 (10)	0.05895 (10)	0.0175 (3)
H24	0.5278	0.1730	0.0397	0.021*
C25	0.56093 (15)	0.32024 (10)	0.08525 (10)	0.0161 (2)
H25	0.6521	0.3246	0.0818	0.019*
C26	0.49997 (13)	0.40221 (10)	0.11640 (9)	0.0128 (2)
O1S	0.03314 (10)	0.15416 (8)	0.02750 (8)	0.01819 (19)
C1S	−0.07218 (16)	0.14179 (12)	0.07676 (12)	0.0229 (3)
H1SA	−0.0761	0.2020	0.1174	0.027*
H1SB	−0.0539	0.0811	0.1195	0.027*
C2S	−0.20485 (16)	0.12945 (12)	−0.00295 (13)	0.0261 (3)
H2SA	−0.2536	0.1949	−0.0179	0.031*
H2SB	−0.2648	0.0793	0.0161	0.031*
C3S	−0.15910 (16)	0.09175 (12)	−0.08984 (12)	0.0255 (3)
H3SA	−0.1453	0.0173	−0.0871	0.031*

H3SB	-0.2257	0.1098	-0.1526	0.031*
C4S	-0.02636 (17)	0.14755 (13)	-0.07673 (11)	0.0245 (3)
H4SA	0.0341	0.1097	-0.1077	0.029*
H4SB	-0.0426	0.2161	-0.1061	0.029*

*Atomic displacement parameters (Å<sup>2</sup>)*

	$U^{11}$	$U^{22}$	$U^{33}$	$U^{12}$	$U^{13}$	$U^{23}$
Br1	0.02180 (7)	0.01121 (5)	0.01197 (6)	0.00286 (5)	0.00268 (5)	0.00115 (4)
Mn1	0.01186 (9)	0.00999 (8)	0.01105 (8)	0.00139 (7)	0.00341 (7)	0.00011 (7)
O1	0.0232 (5)	0.0170 (5)	0.0247 (5)	0.0028 (4)	0.0110 (4)	-0.0031 (4)
C1	0.0152 (6)	0.0146 (5)	0.0138 (6)	-0.0007 (5)	0.0044 (5)	0.0015 (4)
O2	0.0215 (5)	0.0314 (6)	0.0158 (5)	0.0088 (4)	0.0020 (4)	0.0028 (4)
C2	0.0154 (6)	0.0152 (6)	0.0170 (6)	0.0015 (5)	0.0075 (5)	-0.0020 (5)
O3	0.0221 (5)	0.0279 (6)	0.0248 (5)	-0.0059 (4)	0.0115 (5)	-0.0049 (4)
C3	0.0187 (6)	0.0156 (6)	0.0143 (6)	0.0009 (5)	0.0050 (5)	-0.0025 (5)
O10	0.0188 (5)	0.0100 (4)	0.0261 (5)	0.0005 (4)	0.0082 (4)	0.0000 (4)
N11	0.0138 (5)	0.0116 (5)	0.0121 (5)	0.0019 (4)	0.0044 (4)	0.0015 (4)
C12	0.0157 (6)	0.0127 (5)	0.0127 (5)	0.0010 (4)	0.0039 (5)	0.0012 (4)
C13	0.0163 (6)	0.0167 (6)	0.0190 (6)	-0.0034 (5)	0.0044 (5)	0.0001 (5)
C14	0.0141 (6)	0.0231 (7)	0.0222 (7)	-0.0012 (5)	0.0055 (5)	-0.0003 (5)
C15	0.0152 (6)	0.0184 (6)	0.0201 (6)	0.0027 (5)	0.0064 (5)	0.0003 (5)
C16	0.0153 (6)	0.0136 (5)	0.0108 (5)	0.0025 (4)	0.0040 (5)	0.0012 (4)
O20	0.0153 (5)	0.0188 (5)	0.0360 (6)	-0.0021 (4)	0.0057 (5)	-0.0110 (5)
N21	0.0134 (5)	0.0122 (4)	0.0120 (5)	0.0021 (4)	0.0022 (4)	-0.0006 (4)
C22	0.0151 (6)	0.0147 (6)	0.0149 (6)	0.0008 (5)	0.0024 (5)	-0.0024 (5)
C23	0.0216 (7)	0.0123 (5)	0.0172 (6)	0.0011 (5)	0.0041 (5)	-0.0028 (5)
C24	0.0238 (7)	0.0130 (6)	0.0172 (6)	0.0048 (5)	0.0081 (5)	-0.0006 (5)
C25	0.0191 (6)	0.0140 (5)	0.0171 (6)	0.0029 (5)	0.0082 (5)	0.0006 (5)
C26	0.0156 (6)	0.0129 (5)	0.0100 (5)	0.0023 (4)	0.0039 (5)	0.0008 (4)
O1S	0.0168 (5)	0.0190 (5)	0.0194 (5)	-0.0015 (4)	0.0060 (4)	-0.0021 (4)
C1S	0.0224 (7)	0.0264 (7)	0.0229 (7)	0.0003 (6)	0.0114 (6)	0.0015 (6)
C2S	0.0174 (7)	0.0230 (7)	0.0388 (9)	0.0006 (6)	0.0095 (7)	-0.0029 (6)
C3S	0.0230 (7)	0.0209 (7)	0.0285 (8)	-0.0017 (6)	0.0008 (6)	-0.0052 (6)
C4S	0.0294 (8)	0.0264 (8)	0.0185 (7)	-0.0050 (6)	0.0078 (6)	-0.0020 (6)

*Geometric parameters (Å, °)*

Br1—Mn1	2.5532 (3)	N21—C22	1.3407 (17)
Mn1—C1	1.8043 (14)	N21—C26	1.3658 (17)
Mn1—C2	1.7895 (14)	C22—C23	1.4023 (18)
Mn1—C3	1.8093 (14)	C23—H23	0.9500
Mn1—N11	2.0757 (11)	C23—C24	1.372 (2)
Mn1—N21	2.0605 (11)	C24—H24	0.9500
O1—C1	1.1487 (16)	C24—C25	1.393 (2)
O2—C2	1.1492 (17)	C25—H25	0.9500
O3—C3	1.1503 (17)	C25—C26	1.3815 (18)
O10—H10	0.83 (2)	O1S—C1S	1.4510 (17)

O10—C12	1.3368 (16)	O1S—C4S	1.4416 (18)
N11—C12	1.3384 (17)	C1S—H1SA	0.9900
N11—C16	1.3648 (16)	C1S—H1SB	0.9900
C12—C13	1.4007 (19)	C1S—C2S	1.516 (2)
C13—H13	0.9500	C2S—H2SA	0.9900
C13—C14	1.376 (2)	C2S—H2SB	0.9900
C14—H14	0.9500	C2S—C3S	1.524 (2)
C14—C15	1.394 (2)	C3S—H3SA	0.9900
C15—H15	0.9500	C3S—H3SB	0.9900
C15—C16	1.3806 (19)	C3S—C4S	1.510 (2)
C16—C26	1.4721 (19)	C4S—H4SA	0.9900
O20—H20	0.80 (2)	C4S—H4SB	0.9900
O20—C22	1.3294 (17)		
C1—Mn1—Br1	89.64 (4)	O20—C22—N21	115.09 (12)
C1—Mn1—C3	84.52 (6)	O20—C22—C23	122.35 (12)
C1—Mn1—N11	98.36 (5)	N21—C22—C23	122.56 (13)
C1—Mn1—N21	175.75 (5)	C22—C23—H23	120.6
C2—Mn1—Br1	176.95 (4)	C24—C23—C22	118.85 (13)
C2—Mn1—C1	88.30 (6)	C24—C23—H23	120.6
C2—Mn1—C3	90.13 (6)	C23—C24—H24	120.3
C2—Mn1—N11	96.27 (5)	C23—C24—C25	119.32 (12)
C2—Mn1—N21	94.71 (5)	C25—C24—H24	120.3
C3—Mn1—Br1	87.43 (5)	C24—C25—H25	120.5
C3—Mn1—N11	173.04 (5)	C26—C25—C24	118.99 (13)
C3—Mn1—N21	98.45 (5)	C26—C25—H25	120.5
N11—Mn1—Br1	86.26 (3)	N21—C26—C16	114.61 (11)
N21—Mn1—Br1	87.48 (3)	N21—C26—C25	122.29 (12)
N21—Mn1—N11	78.35 (4)	C25—C26—C16	123.05 (12)
O1—C1—Mn1	173.11 (12)	C4S—O1S—C1S	109.52 (11)
O2—C2—Mn1	176.22 (12)	O1S—C1S—H1SA	110.5
O3—C3—Mn1	173.41 (12)	O1S—C1S—H1SB	110.5
C12—O10—H10	111.3 (16)	O1S—C1S—C2S	106.33 (12)
C12—N11—Mn1	127.17 (9)	H1SA—C1S—H1SB	108.7
C12—N11—C16	117.75 (11)	C2S—C1S—H1SA	110.5
C16—N11—Mn1	114.38 (9)	C2S—C1S—H1SB	110.5
O10—C12—N11	115.28 (12)	C1S—C2S—H2SA	111.1
O10—C12—C13	121.90 (12)	C1S—C2S—H2SB	111.1
N11—C12—C13	122.82 (12)	C1S—C2S—C3S	103.23 (12)
C12—C13—H13	120.8	H2SA—C2S—H2SB	109.1
C14—C13—C12	118.49 (13)	C3S—C2S—H2SA	111.1
C14—C13—H13	120.8	C3S—C2S—H2SB	111.1
C13—C14—H14	120.2	C2S—C3S—H3SA	111.3
C13—C14—C15	119.54 (13)	C2S—C3S—H3SB	111.3
C15—C14—H14	120.2	H3SA—C3S—H3SB	109.2
C14—C15—H15	120.7	C4S—C3S—C2S	102.18 (12)
C16—C15—C14	118.67 (13)	C4S—C3S—H3SA	111.3
C16—C15—H15	120.7	C4S—C3S—H3SB	111.3



N11—C16—C15	122.50 (12)	O1S—C4S—C3S	105.28 (12)
N11—C16—C26	114.58 (11)	O1S—C4S—H4SA	110.7
C15—C16—C26	122.89 (12)	O1S—C4S—H4SB	110.7
C22—O20—H20	111.0 (17)	C3S—C4S—H4SA	110.7
C22—N21—Mn1	126.56 (9)	C3S—C4S—H4SB	110.7
C22—N21—C26	117.88 (11)	H4SA—C4S—H4SB	108.8
C26—N21—Mn1	115.50 (8)		
Mn1—N11—C12—O10	-15.18 (17)	C15—C16—C26—C25	-7.6 (2)
Mn1—N11—C12—C13	164.82 (10)	C16—N11—C12—O10	175.02 (11)
Mn1—N11—C16—C15	-165.73 (11)	C16—N11—C12—C13	-4.98 (19)
Mn1—N11—C16—C26	16.04 (14)	O20—C22—C23—C24	176.82 (14)
Mn1—N21—C22—O20	6.44 (18)	N21—C22—C23—C24	-3.0 (2)
Mn1—N21—C22—C23	-173.72 (10)	C22—N21—C26—C16	176.89 (11)
Mn1—N21—C26—C16	-5.87 (14)	C22—N21—C26—C25	-0.53 (19)
Mn1—N21—C26—C25	176.72 (10)	C22—C23—C24—C25	0.1 (2)
O10—C12—C13—C14	-178.55 (13)	C23—C24—C25—C26	2.4 (2)
N11—C12—C13—C14	1.4 (2)	C24—C25—C26—C16	-179.43 (12)
N11—C16—C26—N21	-6.80 (16)	C24—C25—C26—N21	-2.2 (2)
N11—C16—C26—C25	170.60 (12)	C26—N21—C22—O20	-176.65 (12)
C12—N11—C16—C15	5.36 (19)	C26—N21—C22—C23	3.18 (19)
C12—N11—C16—C26	-172.87 (11)	O1S—C1S—C2S—C3S	23.09 (16)
C12—C13—C14—C15	1.9 (2)	C1S—O1S—C4S—C3S	-21.18 (16)
C13—C14—C15—C16	-1.5 (2)	C1S—C2S—C3S—C4S	-34.94 (16)
C14—C15—C16—N11	-2.2 (2)	C2S—C3S—C4S—O1S	34.76 (16)
C14—C15—C16—C26	175.91 (13)	C4S—O1S—C1S—C2S	-1.46 (16)
C15—C16—C26—N21	174.98 (12)		

*Hydrogen-bond geometry (Å, °)*

<i>D</i> —H $\cdots$ <i>A</i>	<i>D</i> —H	H $\cdots$ <i>A</i>	<i>D</i> $\cdots$ <i>A</i>	<i>D</i> —H $\cdots$ <i>A</i>
O10—H10 $\cdots$ Br1 <sup>i</sup>	0.83 (2)	2.39 (2)	3.2098 (10)	170 (2)
O20—H20 $\cdots$ O1S	0.80 (2)	1.79 (2)	2.5903 (15)	176 (2)

Symmetry code: (i)  $-x+1, y+1/2, -z+1/2$ .