

## ORIGINAL RESEARCH

# Optimizing the identification of risk-relevant mutations by multigene panel testing in selected hereditary breast/ovarian cancer families

Anna Coppa<sup>1</sup>, Arianna Nicolussi<sup>1</sup>, Sonia D'Inzeo<sup>1</sup>, Carlo Capalbo<sup>2</sup>, Francesca Belardinilli<sup>2</sup>, Valeria Colicchia<sup>2</sup>, Marialaura Petroni<sup>3</sup>, Massimo Zani<sup>2</sup>, Sergio Ferraro<sup>2</sup>, Christian Rinaldi<sup>2</sup>, Amelia Buffone<sup>2</sup>, Armando Bartolazzi<sup>4</sup>, Isabella Screpanti<sup>2</sup>, Laura Ottini<sup>2</sup> & Giuseppe Giannini<sup>2,5</sup> 

<sup>1</sup>Department of Experimental Medicine, University La Sapienza, V.le R. Elena 324, Rome 00161, Italy

<sup>2</sup>Department of Molecular Medicine, University La Sapienza, V.le R. Elena 291, Rome 00161, Italy

<sup>3</sup>Center for Life Nano Science@Sapienza, Istituto Italiano di Tecnologia, Rome 00161, Italy

<sup>4</sup>Department of Pathology, Sant'Andrea Hospital, University La Sapienza, Via di Grottarossa 1035, Rome 00189, Italy

<sup>5</sup>Istituto Pasteur-Fondazione Cenci Bolognetti, Rome 00161, Italy

## Keywords

ATM, BRCAPro5, CHEK2, hereditary breast cancer, NGS

## Correspondence

Giuseppe Giannini, Department of Molecular Medicine, University La Sapienza, v.le R., Elena, 291, 00161 Rome, Italy. Tel: +39 06 4958637; Fax: +39 06 4461974; E-mail: giuseppe.giannini@uniroma1.it

## Funding Information

This work was supported by grants from: Associazione Italiana per la Ricerca sul Cancro (IG17734 to G. Giannini; IG16933 to L. Ottini); Italian Ministry of University and Research, PRIN projects (G. Giannini); Istituto Pasteur-Fondazione Cenci Bolognetti (G. Giannini).

Received: 31 August 2017; Revised: 5 September 2017; Accepted: 9 October 2017

*Cancer Medicine* 2018; 7(1):46–55

doi: 10.1002/cam4.1251

## Abstract

The introduction of multigene panel testing for hereditary breast/ovarian cancer screening has greatly improved efficiency, speed, and costs. However, its clinical utility is still debated, mostly due to the lack of conclusive evidences on the impact of newly discovered genetic variants on cancer risk and lack of evidence-based guidelines for the clinical management of their carriers. In this pilot study, we aimed to test whether a systematic and multiparametric characterization of newly discovered mutations could enhance the clinical utility of multigene panel sequencing. Out of a pool of 367 breast/ovarian cancer families Sanger-sequenced for *BRCA1* and *BRCA2* gene mutations, we selected a cohort of 20 *BRCA1/2*-negative families to be subjected to the BROCA-Cancer Risk Panel massive parallel sequencing. As a strategy for the systematic characterization of newly discovered genetic variants, we collected blood and cancer tissue samples and established lymphoblastoid cell lines from all available individuals in these families, to perform segregation analysis, loss-of-heterozygosity and further molecular studies. We identified loss-of-function mutations in 6 out of 20 high-risk families, 5 of which occurred on *BRCA1*, *CHEK2* and *ATM* and are esteemed to be risk-relevant. In contrast, a novel *RAD50* truncating mutation is most likely unrelated to breast cancer. Our data suggest that integrating multigene panel testing with a pre-organized, multiparametric characterization of newly discovered genetic variants improves the identification of risk-relevant alleles impacting on the clinical management of their carriers.

## Introduction

About 5–10% of breast and/or ovarian cancer cases have a hereditary background, mainly dependent on highly penetrant mutations in the *BRCA1* and *BRCA2* genes [1]. The reported cumulative breast cancer risk by the age of 70 is 55–65% for *BRCA1* and 45–47% for *BRCA2* mutation carriers, while the ovarian cancer risk is 39% for *BRCA1* and 11–17% for *BRCA2* mutation carriers [2, 3]. Differences in mutation type and site may at least partially impact on cancer risk definition [4, 5].

*BRCA1* and *BRCA2* gene mutations are typically found in 25–30% of the breast cancer families subjected to genetic testing [6, 7]. Therefore, the search for germline mutations has often remained negative even in families with a Mendelian inheritance pattern for breast and/or ovarian cancer [8]. However, recent improvements in DNA sequencing technology enabled massively parallel sequencing of multiple targets, dramatically improving the speed and the efficiency of DNA testing. A number of different multigene panels have been designed for the analysis of hereditary cancer syndrome families, which may include

relatively few and syndrome-oriented target genes, or much larger gene sets [9–11]. Similar approaches have now been applied to the screening of large cohorts of *BRCA1/2* negative hereditary breast/ovarian cancer families finding mutations in non-*BRCA1/2* genes in 4–11% of the cases, depending on the features of the patients cohorts and/or on the size of the multigene panel [10–15]. In these studies, loss-of-function mutations were identified either in known, syndrome-related highly penetrant genes (i.e., *TP53* and *PTEN*) or in a number of rarely mutated targets, whose impact on breast/ovarian cancer risk is largely undefined [11, 15, 16]. Accordingly, the introduction of Next generation sequencing (NGS) multigene panels for diagnostic purposes is still debated, since their clinical utility is often limited by scant information on the cancer risk conferred by rare genetic variants and lack of evidence-based guidelines for the clinical management of their carriers [16]. Large case–control studies have recently confirmed *PALB2* as a high-risk breast cancer gene, but they still reached conflicting results on *ATM* and *CHEK2* and rejected the role of many other genes, such as those of the MRN complex [17, 18].

Defining the impact of gene mutations on cancer risk might be a very difficult task especially for rarely mutated genes, hit by different mutation types in different sites. Nonetheless, aiming at this target is mandatory for a correct application of multigene panel sequencing in the clinical settings. To focus on this key question, we reasoned that integrating gene panel sequencing with the systematic use of prediction tools, cosegregation and loss of heterozygosity (LOH) analysis, together with the availability of patient-derived lymphoblastoid cell lines (LCL) for functional studies could provide significant hints on the impact of newly discovered gene mutations on cancer risk, improving the clinical utility of NGS screenings. In this pilot study, we report on the application of this strategy to a cohort of twenty breast/ovarian cancer families with a moderate-to-high probability to be mutation carriers.

## Materials and Methods

### Family recruitment

About 367 breast and/or ovarian cancer families were enrolled at the Hereditary Tumors section of the Policlinico Umberto I, University La Sapienza, and probands have been subjected to *BRCA1/2* mutation screening (Table S1) [19, 20]. Out of the *BRCA1/2* negative group, we selected 20 (BRCAX) families characterized by high probability to be mutation carriers, as described in the Results section. DNA samples from peripheral blood or cancer tissues, were subjected to multigene panel NGS or Sanger sequencing, respectively. Lymphoblastoid cell lines (LCL) were generated

from probands and available relatives, using a standard protocol [21]. A careful pretest counseling has been offered to all probands and their relatives to obtain a truly informed consent. All investigations were conducted according to the principles outlined in the declaration of Helsinki.

### *BRCA1/2* mutation screening

Genomic DNA was extracted from peripheral blood samples using a commercial kit (QIAamp Blood Kit, Qiagen, Valencia, CA). The entire coding sequence and all intron/exon boundaries of *BRCA1* and *BRCA2* were screened by direct sequencing using an ABI PRISM DyeDeoxy Terminator Cycle Sequencing Kit and an ABI 3130XL Genetic Analyzer (Applied Biosystems, Warrington, UK) as previously described [19, 20]. Sequences were compared against *BRCA1* and *BRCA2* reference sequences (GenBank NM\_007294.3 and NM\_000059.3; additional GenBank reference sequence were as follows: *ATM*, NM\_000051.3; *CHEK2*, NM\_007194.3; *RAD50*, NM\_005732.3). DNA mutation nomenclature followed current guidelines of the Human Genome Variation Society (<http://www.hgvs.org/rec.html>). *BRCA1/2* genomic rearrangements were searched for by the Multiple-Ligation-dependent-Probe-Amplification (MLPA) methodology according to the manufacturer's instructions (MRC–Holland, Amsterdam, the Netherlands) and as described [22].

### Next generation sequencing

NGS and data analysis have been performed on service at the University of Washington–Seattle using the BROCA–Cancer Risk panel (<http://tests.labmed.washington.edu/BROCA>), an approach of genomic capture and massively parallel sequencing of 41 putative breast/ovarian cancer genes, according to Walsh et al. [12]. All described variants were subsequently validated in our laboratory by Sanger sequencing.

### RNA extraction and RT-PCR

LCLs were untreated and treated with cycloheximide (CHX, 100 µg/mL) for 4 h in order to block non-sense mediated decay. Total RNA extraction was performed using TRI Reagent® (Sigma-Aldrich, Co.) according to the manufacturer's instructions. 1 µg of the RNA was retro-transcribed and PCR amplified as described [23] (primer sequences are available on request).

### Tumor-tissue histology

For each paraffin-embedded tumor, six 10-µm paraffin slides were used for genomic-DNA isolation [24, 25] and

a hematoxylin-eosin–stained slide was used for histopathological examination.

## Results

On a sample of 266 breast cancer (BC) and 101 breast/ovarian cancer families (BOC) Sanger sequenced for *BRCA1/2* genes, 97 (26%) carried deleterious mutations (Table S1). In line with the literature [1, 7], the mutational rate in BC families was dramatically lower (13%) compared to BOC families (60%), suggesting that a high percentage of them remains without a conclusive genetic diagnosis.

To extend the possibility to identify mutations responsible for breast cancer inheritance, we applied multigene panel sequencing to a small cohort of hereditary BC/BOC families, which shared the following criteria: (1) being negative for *BRCA1/2* truncating or missense deleterious mutation, after standard Sanger sequencing; being willing to provide; (2) blood and DNA samples from affected and unaffected individuals to establish LCLs and to perform segregation analysis; and (3) tumor tissue from at least one affected individual to perform LOH studies. In order to provide a proof-of-concept that this strategy may enhance the identification of mutations impacting on cancer risk definition and clinical management of the carrier families, we limited the cohort to 20 families having a clear dominant inheritance pattern and/or a high BRCAPro score. Consistent with the much lower level of *BRCA1/2* mutation rate in BC families, 17 out of 20 were BC families and only three were BOC families (Table 1). Of note, 11 out of the 20 probands showed a very high BRCAPro score (between 97% and 75%) and 6 had a BRCAPro score between 50% and 67%. We also included three families with a BRCAPro <50% that showed co-occurrence of OC and BC, or the presence of bilateral BC before age 38 years in the proband, plus significant family history (Table 1; Table S2).

**Table 1.** Clinical characteristics of BRCAX Probands.

	No. of cases	(%)
Proband cancer history	20	
Unilateral breast	9	45
Bilateral breast	10	50
Ovarian	1	5
Second primary malignancy	2	10
Proband age of cancer onset	20	
25–35	4	20
36–50	14	70
>50	2	10
BRCAPro-5 score (%)	20	
>75	11	55
50–75	6	30
<50	3	15

By this approach, we identified loss-of-function mutations in 6/20 (30%) probands, five of which occurred on *BRCA1*, *CHEK2*, and *ATM* and are esteemed to be risk-relevant according to our studies (Table 2, Fig. 1), while a novel *RAD50* truncating mutation is most likely unrelated to breast cancer. Interestingly, all these mutations occurred in families with a very high BRCAPro score (75–97%).

Despite previous *BRCA1/2* testing, the NGS approach identified two novel *BRCA1* deleterious mutations. One is a *BRCA1/NBR2* rearrangement (*NBR2*del EX1\_ *BRCA1* delEX1-2). PCR amplification of genomic DNA from the BR409 proband resulted in an aberrant fragment of approximately 670 bp (Fig. 2A), whose direct sequencing confirmed the putative breakpoints. As reported in Figure 2, loss of *NBR2* exon1 and *BRCA1* exons 1 and 2 possibly originated from an erroneous homologous recombination process between two AluY motifs, located at chr17:41279963 and at chr17:41273315, respectively (Fig. 2B). We detected this mutation in a 38-year-old woman (BR409), with bilateral breast cancer at age 30 and 32, belonging to a very high-risk family (BRCAPro 91%) (Fig. 1). As expected, this mutation cosegregates with the disease (Table 2).

The second *BRCA1* mutation is a synonymous variant on the last codon of exon 17 (c.5073A>T; p.Thr1691=) already identified, but not considered relevant, at the time of the first Sanger sequencing. The NNSPLICE prediction tool ([http://fruitfly.org:9005/seq\\_tools/splice.html](http://fruitfly.org:9005/seq_tools/splice.html)) suggested it could cause an alternative splicing with skipping of exon 17, and exon 16–18 out-of-frame joining. The functional consequences on this mutation was ascertained by RT-PCR and sequencing analysis of the transcripts in LCLs, which identified the wild type form (Fig. 3A, fragment C) and the predicted aberrant transcript (Fig. 3A, fragment D) skipping exon 17 and carrying a premature stop codon at residue 1672 (p.Met1663 fs). Moreover, we observed an additional transcript (Fig. 3A, fragment A), incorporating a 153 bp sequence of intron 17 (preceding a typical GT 5'-splice signal) that created a stop codon at residue 1706 (p.Asp1692fs). A further 570 bp band (Fig. 3A, fragment B), instead, proved to be a heteroduplex rather than a specific splicing product (Fig. 3B). All the aberrant transcripts were detected in the BR404 proband, but not in control LCLs and they increased with cycloheximide (CHX) treatment, suggesting they all suffer a non-sense mediated decay (Fig. 3A). We identified the c.5073A>T (p.Thr1691=) variant in a woman (BR404, BRCAPro 82%) with bilateral breast cancer at age 73 (Fig. 1). Also in this case, the mutation cosegregated with the diseases in 100% of the cases (Table 2). Moreover, we showed LOH for the mutant allele in the tumor tissue of the proband and both her daughters (Fig. 3D; Table S3). These data strongly suggest that the

**Table 2.** Mutations identified by NGS.

Family ID	Mutation	BCRPro %	Segregation				Total
			Healthy		Affected		
			C	NC	C	NC	
BR409	<i>BRCA1/NBR2</i> NBR2delEX1_BRCA1delEX1-2	91	0	3	2	0	5
BR404	<i>BRCA1</i> c.5073A>T (p.Thr1691=)	75	0	3	3	0	6
BR225	<i>ATM</i> c.8833_8834delCT (p.Leu2945 fs)	91	1	0	4	0	5
BR208	<i>ATM</i> c.824delT (p.Leu275Ter)	82	0	3	2	2	7
BR501	<i>CHEK2</i> c.1232G>A (p.Trp411Ter)	94	4	1	3	1	9
BR17	<i>RAD50</i> c.326_329delCAGA (p.Thr109 fs)	97	5	4	1	2	12

C, carrier; NC, no carrier.

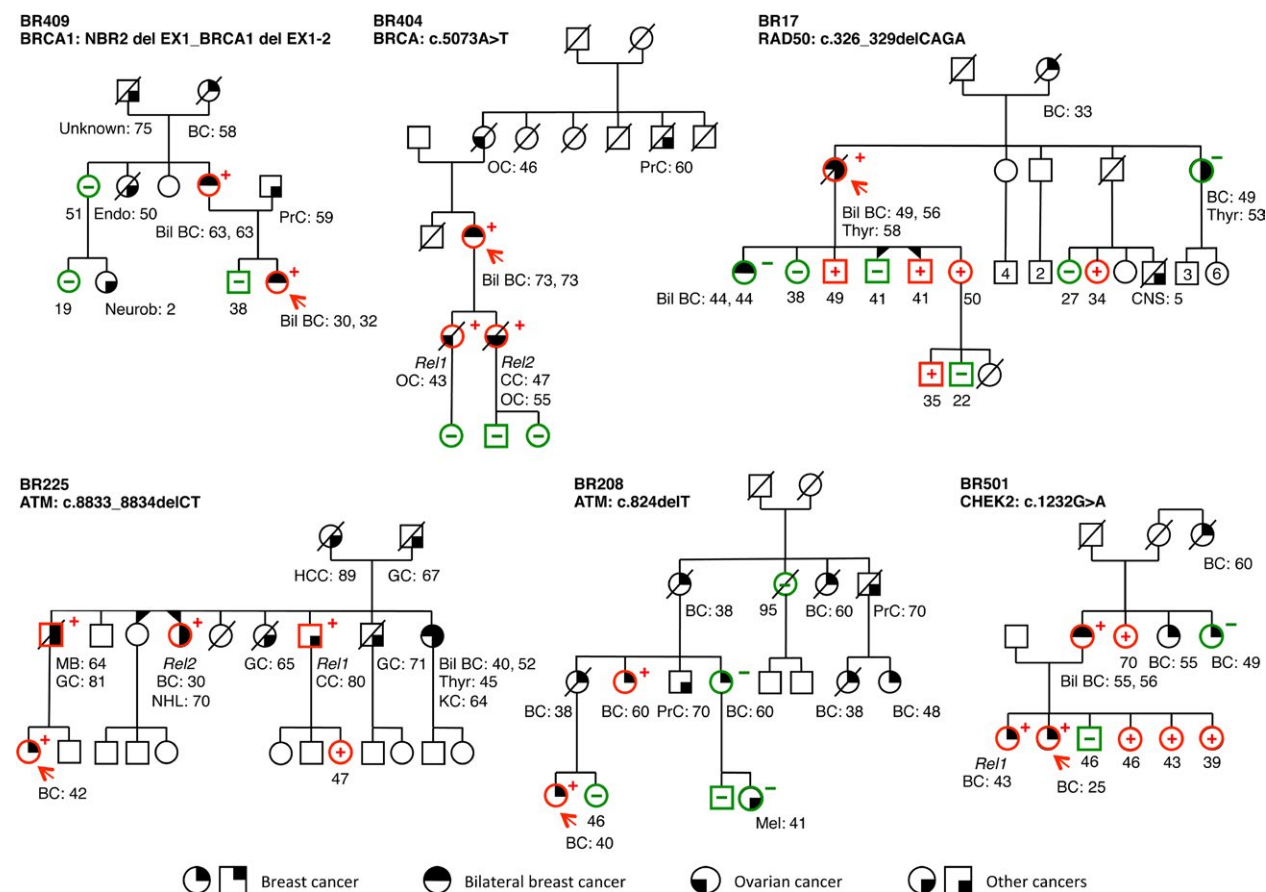
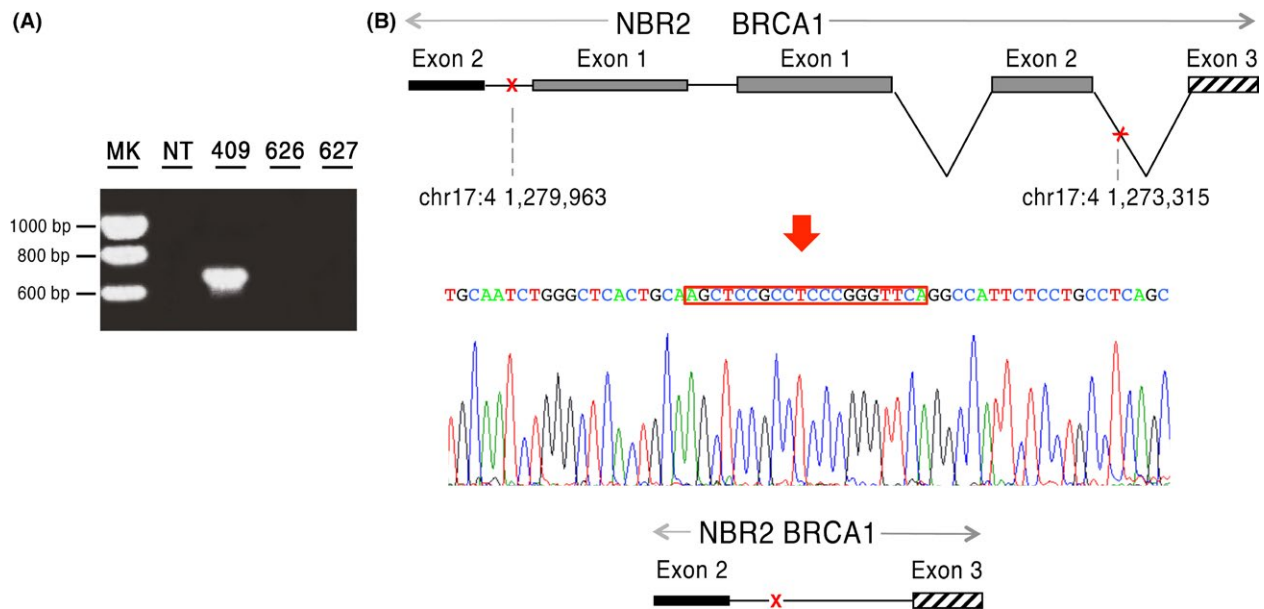

**Figure 1.** Pedigrees of the six families with germline mutations identified by NGS. Probands are indicated with an arrow. Tested family members are marked with "+" for mutation carriers and "-" for wild-type. *Rel1*, *Rel2*: LOH tested family members. Cancer type and age at diagnosis are reported and described as: BC, breast cancer; bil BC, bilateral breast cancer; OC, ovarian cancer; MB, male breast; PrC, prostatic cancer; Unknown cancer; Neurob, neuroblastoma cancer; NHL, non-Hodgkin lymphoma; Thyr, Thyroid; KC, Kidney cancer; Mel, melanoma; CNS, central nervous system cancer; GC, gastric cancer; CC, colon cancer; Endo, endometrial cancer.

*BRCA1/NBR2* rearrangement and *BRCA1* c.5073A>T (p.Thr1691=) are new loss-of-function and cancer risk-relevant mutations.

Two protein-truncating variants occurred on the *ATM* gene. The *ATM* exon 7 c.824delT mutation resulting in

a premature termination at codon 275 (p.Leu275Ter) occurred in the BR208 proband (BCRPro 82%) who was diagnosed with breast cancer at age 40 (Fig. 1). This mutation cosegregated with the disease in two family members affected with early onset breast cancer, but not in an elderly



**Figure 2.** *BRCA1/NBR2* rearrangement identified in the BR409 family. (A) Gel image of PCR products. PCR amplification of the genomic region spanning the *BRCA1/NBR2* rearrangement resulted in a fragment of approximately 670 bp present only in the proband BR409. (B) Schematic representation and electropherogram showing the *NBR2* exon1 and *BRCA1* exons 1 and 2 deletion. The variant arose from an erroneous homologous recombination process between two AluY motifs, localized at chr17:41279963 and at chr17:41273315, respectively, and it involved a perfectly repeated stretch of 20 bp. MK, marker; NT, no template; 409 proband DNA, 627, 626 healthy individual DNA.

BC case, four unaffected relatives and one melanoma case (Table 2). LOH analysis showed maintenance of a heterozygous state of the *ATM* alleles in normal, preneoplastic and neoplastic tissue from the proband (Table S3).

The *ATM* exon 61 c.8833\_8834delCT mutation introduced a stop codon at position 2954 (p.Leu2945fs). It occurred in the BR225 proband (BRCAPro 91%) affected with breast cancer at age 42 (Fig. 1). This mutation cosegregated with the disease in three BC patients (including one male) and one colorectal cancer patients (Table 2). Also in this case, LOH analysis showed maintenance of a heterozygous state, in all tissues examined (Table S3). These results were consistent with a risk-relevant role of *ATM* mutations in both families.

The *CHEK2* nonsense c.1232G>A mutation on exon 11 resulted in a premature protein termination at codon 411 (p.Trp411Ter) predicted to disrupt protein function and occurred in the BR501 proband (BRCAPro 94%), affected with an early onset breast cancer at age 25 (Fig. 1). Extensive segregation analysis in nine individuals of the family indicated the mutation segregated with most breast cancer cases (three out of four) (Table 2). Moreover, we showed LOH for the c.1232G>A mutation in the tumor tissue (Table S3), supporting a risk-relevant role for this mutation.

The novel *RAD50* frameshift c.326\_329delCAGA mutation in the exon 3 introduced a stop codon at position

128 (p.Thr109fs), at the level of the ATPaseN domain, which predicts a very strong impact on the function of the RAD50-MRE11 complex [26]. This mutation occurred in the BR17 proband (BRCAPro 97%), who developed bilateral breast and thyroid cancer at 49, 56, and 58 years, respectively (Fig. 1). Nonetheless, segregation analysis, performed in 12 individuals did not support a critical role of this mutation, since it did not segregate in the other two breast cancer cases (one of which bilateral, at 44) (Table 2).

## Discussion

Recently, the landscape of genetic risk evaluation for breast/ovarian cancer expanded due to the introduction of the NGS technology, which has greatly simplified the search for genetic alterations in targets other than *BRCA1/2*. Many different genes were shown to be mutated in breast/ovarian cancer cohorts, being *PALB2*, *ATM*, and *CHEK2* the most frequent [10–14, 27]. However, the clinical utility of these studies is still controversial since even large case-control studies failed to firmly establish an increased risk for breast and/or ovarian cancer associated with many of the mutated genes [16].

In this pilot study, we reported that association of NGS screenings with the systematic use of prediction tools, cosegregation and LOH analysis and establishment

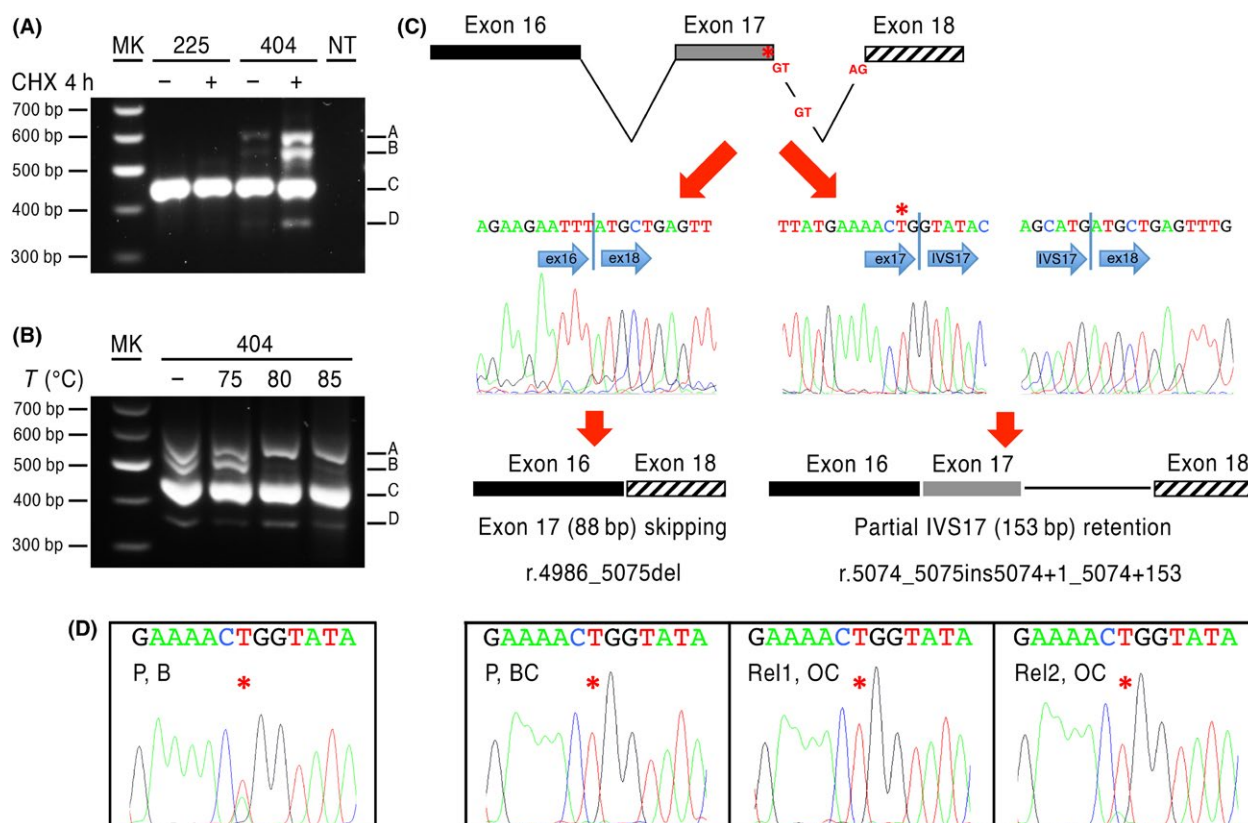

**Figure 3.** *BRCA1* c.5073A>T (p.Thr1691=) identified in the BR404 family. (A) PCR amplification of the alternative transcripts in patient 404 mRNA from LCL exposed or non-exposed to cycloheximide (CHX): (A) 604 bp aberrant fragment; (B) 570 bp aberrant fragment; (C) wt transcript fragment and (D) 363 bp aberrant fragment. (B) Melting and reannealing PCR fragments at rising temperatures (80° and 85°C), allow disappearance of band B, which indicates it is a heteroduplex. (C) Schematic representation and electropherograms of the excised bands showing the presence of a transcript lacking exon17 and of an aberrant transcript retaining a 153 bp fragment of intron 17. (D) Electropherograms of DNA obtained from the blood and cancer tissues of proband and her daughters showing LOH with conservation of the c.5073A>T (p.Thr1691=) allele in all cancer tissues (Table S3). MK, marker; NT, no template; 225 control LCL; 404 proband LCL; P, B, Proband blood sample; P, BC, Proband breast cancer tissue; Rel1, OC, Relative 1 ovarian cancer tissue; Rel2, OC, Relative 2 ovarian cancer tissue.

patient-derived LCL for functional studies improves the identification of risk-relevant gene mutations. A similar approach had been previously used to establish the clinical significance of uncharacterized *BRCA1/2* missense mutations [28]. Indeed, the information gathered by this approach influenced the choice for the appropriate risk-reducing strategy for 5/6 families, in which loss-of-function mutations have been detected.

This was rather straightforward for two of them, which are novel *BRCA1* disease causing mutations, falling into class V, according to Plon et al. [29]. Indeed, one is a novel *BRCA1/NBR2* rearrangement, which may lead to lack of *BRCA1* transcription, as described for previously reported genomic rearrangements [30, 31]. The second is a novel *BRCA1* synonymous variant (c.5073A>T; p.Thr1691=). Our studies on LCL were crucial to demonstrate it gives rise to aberrant alternative transcripts that undergo nonsense-mediated decay and code for

truncated proteins. Since, similar outcomes were previously reported for the c.5074+1G>T variant affecting the consensus GT splicing signal in intron 17 [32], our data reveal that the c.5073A>T substitution impairs a strong splicing enhancer. The segregation pattern of both mutations and LOH analysis further support the disease-causing role of both *BRCA1* mutations.

The two *ATM* protein-truncating mutations we identified for the first time in breast cancer families, had already been reported as either homozygous or compound heterozygous alterations in Ataxia-Telangiectasia patients [33, 34], but their impact on cancer risk was not previously described. These mutations segregate in most siblings affected with breast and/or other types of cancer. Interestingly, we observed no LOH for *ATM* variants, in line with the hypothesis that one mutant *ATM* allele may be sufficient to promote tumor initiation [35, 36]. Importantly, both *ATM* mutations were also picked up

by the p53 mitotic centrosomal localization test, indicating they are functionally impaired in governing p53 centrosomal localization [37]. Overall, our data strongly support the role of these *ATM* mutations in cancer development, in these families.

The novel c.1232G>A is a truncating and function disrupting mutation of the *CHEK2* gene, identified in an early onset breast cancer proband. The high number of breast cancers observed in this family, cosegregation of the variant with the disease and its LOH in the breast cancer tissue, strongly suggest this is a breast cancer predisposing allele.

It is worth mentioning that, in principle, the role of mutant *ATM* and *CHEK2* as breast cancer genes is still debated. However, many studies and a large meta-analysis agree that *ATM* mutations confer a moderate breast cancer risk [36, 38, 39] although there might be differences between truncating versus missense mutations [40]. Moreover, a specific missense allele (c.7271T>G) was reported to be associated even with high breast cancer risk [41]. In a similar way, the reported breast cancer risk for *CHEK2* mutations varies largely. The cumulative breast cancer risk conferred by the 1100delC *CHEK2* variant is 37% at 70 years [42]. Association studies on four different *CHEK2* variants, indicated a breast cancer risk of 20–44% and 9–12% for truncating mutations and missense mutation carriers, respectively, largely depending on their family history [43]. A recent case–control study on a large cohort of patients subjected to multigene panel testing further suggest that *ATM* and *CHEK2* are associated with moderate breast cancer risk [18], providing support to NCCN recommendations for an annual magnetic resonance screening of these mutation carriers, starting at age 40 [44]. Based on our observations and on the knowledge that other genes, such as *PALB2*, have been recently re-classified from moderate to high-penetrance BC susceptibility gene [45], we suggest that extreme caution is required in defining *ATM*- or *CHEK2*-dependent cancer risk, and that at least extensive segregation analysis and LOH studies should be performed for each mutation, in order to more appropriately define the clinical utility of mutation detection for those genes.

Interestingly, the novel c.326\_329delCAGA *RAD50* mutation identified in the BR17 family with a very high BRCAPro score (97%) exemplifies the challenges in transferring genetic data into clinical management deriving from multigene panel sequencing, and further contribute to support the efficacy of our strategy. Indeed, while this protein-truncating mutation predicts loss-of-function of the RAD50-MRE11 complex [26], it did not cosegregate with breast cancer, suggesting it is unlikely to be the risk-relevant allele in the BR17 family, where additional genetic alterations might be responsible for cancer inheritance.

Importantly, large case–control studies have also indicated lack of significant association between MRN complex gene mutations and breast cancer risk [17, 18].

Although uneasy to be performed on large scale and in non-research oriented environment, our proposed approach identified risk-relevant mutations in 25% of the analyzed families. Excluding the two *BRCA1* mutations, we identified risk-relevant mutations in non-*BRCA1/2* genes in 17% of the families. Therefore, the combination of multigene panel sequencing with extended and multiparametric characterization of the discovered mutations, eventually restricted to families with high probability of being mutation carriers, stands as very useful approach to increase the clinical utility of NGS screening for inherited breast/ovarian cancer.

Finally, we cannot overlook that a consistent number of high-risk families still remained without satisfying answers despite multigene panel sequencing, in our and other's studies [13, 46]. The overall strategy depicted here could be further exploited to identify risk-relevant mutations in these families by additional mutation screenings such as whole exome sequencing and/or RNAseq.

In conclusion, we have shown that integrating the systematic use of cosegregation analysis, LOH and functional studies performed on LCL with multigene panel sequencing may improve its clinical utility and the clinical management of the mutation carriers.

## Conflict of Interest

The authors declared no conflict of interest.

## References

1. Foulkes, W. D. 2008. Inherited susceptibility to common cancers. *N. Engl. J. Med.* 359:2143–2153. <https://doi.org/10.1056/NEJMra0802968>.
2. Antoniou, A., P. D. P. Pharoah, S. Narod, H. A. Risch, J. E. Eyfjord, J. L. Hopper, et al. 2003. Average risks of breast and ovarian cancer associated with BRCA1 or BRCA2 mutations detected in case Series unselected for family history: a combined analysis of 22 studies. *Am. J. Hum. Genet.* 72:1117–1130. <https://doi.org/10.1086/375033>.
3. Chen, S., and G. Parmigiani. 2007. Meta-analysis of BRCA1 and BRCA2 penetrance. *J. Clin. Oncol.* 25:1329–1333. <https://doi.org/10.1200/JCO.2006.09.1066>.
4. Rebbeck, T. R., N. Mitra, F. Wan, O. M. Sinilnikova, S. Healey, L. McGuffog, et al. 2015. Association of type and location of BRCA1 and BRCA2 mutations with risk of breast and ovarian cancer. *JAMA* 313:1347–1361. <https://doi.org/10.1001/jama.2014.5985>.
5. Coppa, A., A. Buffone, C. Capalbo, A. Nicolussi, S. D'Inzeo, F. Belardinilli, et al. 2014. Novel and recurrent

- BRCA2 mutations in Italian breast/ovarian cancer families widen the ovarian cancer cluster region boundaries to exons 13 and 14. *Breast Cancer Res. Treat.* 148:629–635. <https://doi.org/10.1007/s10549-014-3196-z>.
6. Capalbo, C., E. Ricevuto, A. Vestri, E. Ristori, T. Sidoni, A. Buffone, et al. 2006. BRCA1 and BRCA2 genetic testing in Italian breast and/or ovarian cancer families: mutation spectrum and prevalence and analysis of mutation prediction models. *Ann. Oncol.* 17(Suppl 7):vii34–vii40. <https://doi.org/10.1093/annonc/mdl947>.
  7. Economopoulou, P., G. Dimitriadis, and A. Psyrri. 2015. Beyond BRCA: new hereditary breast cancer susceptibility genes. *Cancer Treat. Rev.* 41:1–8. <https://doi.org/10.1016/j.ctrv.2014.10.008>.
  8. Stratton, M. R., and N. Rahman. 2008. The emerging landscape of breast cancer susceptibility. *Nat. Genet.* 40:17–22. <https://doi.org/10.1038/ng.2007.53>.
  9. Walsh, T., M. K. Lee, S. Casadei, A. M. Thornton, S. M. Stray, C. Pennil, et al. 2010. Detection of inherited mutations for breast and ovarian cancer using genomic capture and massively parallel sequencing. *Proc. Natl Acad. Sci. USA* 107:12629–12633. <https://doi.org/10.1073/pnas.1007983107>.
  10. LaDuca, H., A. J. Stuenkel, J. S. Dolinsky, S. Keiles, S. Tandy, T. Pesaran, et al. 2014. Utilization of multigene panels in hereditary cancer predisposition testing: analysis of more than 2000 patients. *Genet. Med.* 16:830. <https://doi.org/10.1038/gim.2014.40>.
  11. Kurian, A. W., E. E. Hare, M. A. Mills, K. E. Kingham, L. McPherson, A. S. Whittemore, et al. 2014. Clinical evaluation of a multiple-gene sequencing panel for hereditary cancer risk assessment. *J. Clin. Oncol.* 32:2001–2009. <https://doi.org/10.1200/JCO.2013.53.6607>.
  12. Walsh, T., S. Casadei, M. K. Lee, C. C. Pennil, A. S. Nord, A. M. Thornton, et al. 2011. Mutations in 12 genes for inherited ovarian, fallopian tube, and peritoneal carcinoma identified by massively parallel sequencing. *Proc. Natl Acad. Sci.* 108:18032–18037. <https://doi.org/10.1073/pnas.1115052108>.
  13. Tung, N., N. U. Lin, J. Kidd, B. A. Allen, N. Singh, R. J. Wenstrup, et al. 2016. Frequency of germline mutations in 25 cancer susceptibility genes in a sequential series of patients with breast cancer. *J. Clin. Oncol.* 34:1460–1468. <https://doi.org/10.1200/JCO.2015.65.0747>.
  14. Castera, L., S. Krieger, A. Rousselin, A. Legros, J. J. Baumann, O. Bruet, et al. 2014. Next-generation sequencing for the diagnosis of hereditary breast and ovarian cancer using genomic capture targeting multiple candidate genes. *Eur. J. Hum. Genet.* 22:1305–1313. <https://doi.org/10.1038/ejhg.2014.16>.
  15. Desmond, A., A. W. Kurian, M. Gabree, M. A. Mills, M. J. Anderson, Y. Kobayashi, et al. 2015. Clinical actionability of multigene panel testing for hereditary breast and ovarian cancer risk assessment. *JAMA Oncol.* 1:943–951. <https://doi.org/10.1001/jamaoncol.2015.2690>.
  16. Easton, D. F., P. D. P. Pharoah, A. C. Antoniou, M. Tischkowitz, S. V. Tavtigian, K. L. Nathanson, et al. 2015. Gene-panel sequencing and the prediction of breast-cancer risk. *N. Engl. J. Med.* 372:2243–2257. <https://doi.org/10.1056/NEJMSr1501341>.
  17. Thompson, E. R., S. M. Rowley, N. Li, S. McNerny, L. Devereux, M. W. Wong-Brown, et al. 2016. Panel testing for familial breast cancer: calibrating the tension between research and clinical care. *J. Clin. Oncol.* 34:1455–1459. <https://doi.org/10.1200/JCO.2015.63.7454>.
  18. Couch, F. J., H. Shimelis, C. Hu, S. N. Hart, E. C. Polley, J. Na, et al. 2017. Associations between cancer predisposition testing panel genes and breast cancer. *JAMA Oncol.* 3:1190. <https://doi.org/10.1001/jamaoncol.2017.0424>.
  19. Giannini, G., C. Capalbo, E. Ristori, E. Ricevuto, T. Sidoni, A. Buffone, et al. 2006. Novel BRCA1 and BRCA2 germline mutations and assessment of mutation spectrum and prevalence in Italian breast and/or ovarian cancer families. *Breast Cancer Res. Treat.* 100:83–91. <https://doi.org/10.1007/s10549-006-9225-9>.
  20. Capalbo, C., E. Ricevuto, A. Vestri, T. Sidoni, A. Buffone, E. Cortesi, et al. 2006. Improving the accuracy of BRCA1/2 mutation prediction: validation of the novel country-customized IC software. *Eur. J. Hum. Genet.* 14:49–54. <https://doi.org/10.1038/sj.ejhg.5201511>.
  21. Neitzel, H. 1986. A routine method for the establishment of permanent growing lymphoblastoid cell lines. *Hum. Genet.* 73:320–326.
  22. Buffone, A., C. Capalbo, E. Ricevuto, T. Sidoni, L. Ottini, M. Falchetti, et al. 2007. Prevalence of BRCA1 and BRCA2 genomic rearrangements in a cohort of consecutive Italian breast and/or ovarian cancer families. *Breast Cancer Res. Treat.* 106:289–296. <https://doi.org/10.1007/s10549-007-9499-6>.
  23. Nicolussi, A., S. D’Inzeo, G. Mincione, A. Buffone, M. C. Di Marcantonio, R. Cotellese, et al. 2014. PRDX1 and PRDX6 are repressed in papillary thyroid carcinomas via BRAF V600E-dependent and -independent mechanisms. *Int. J. Oncol.* 44:548–556. <https://doi.org/10.3892/ijo.2013.2208>.
  24. Belardinelli, F., C. Capalbo, A. Buffone, M. Petroni, V. Colicchia, S. Ferraro, et al. 2015. Validation of the ion torrent PGM sequencing for the prospective routine molecular diagnostic of colorectal cancer. *Clin. Biochem.* 48:908–910. <https://doi.org/10.1016/j.clinbiochem.2015.04.003>.
  25. Giannini, G., C. Capalbo, L. Ottini, M. Petroni, V. Colicchia, S. Ferraro, et al. 2008. Clinical classification of BRCA1 DNA missense variants: H1686Q is a novel pathogenic mutation occurring in the ontogenetically



- invariant THV motif of the N-terminal BRCT domain. *J. Clin. Oncol.* 26:4212–4214 <https://doi.org/10.1200/jco.2008.18.2089>.
26. Williams, G. J., S. P. Lees-Miller, and J. A. Tainer. 2010. Mre11-Rad50-Nbs1 conformations and the control of sensing, signaling, and effector responses at DNA double-strand breaks. *DNA Repair* 9:1299–1306. <https://doi.org/10.1016/j.dnarep.2010.10.001>.
  27. Lincoln, S. E., Y. Kobayashi, M. J. Anderson, S. Yang, A. J. Desmond, M. A. Mills, et al. 2015. A systematic comparison of traditional and multigene panel testing for hereditary breast and ovarian cancer genes in more than 1000 patients. *J. Mol. Diagn.* 17:533–544. <https://doi.org/10.1016/j.jmoldx.2015.04.009>.
  28. Lindor, N. M., L. Guidugli, X. Wang, M. P. Vallée, A. N. Monteiro, S. Tavtigian, et al. 2012. A review of a multifactorial probability-based model for classification of BRCA1 and BRCA2 variants of uncertain significance (VUS). *Hum. Mutat.* 33:8–21. <https://doi.org/10.1002/humu.21627>.
  29. Plon, S. E., D. M. Eccles, D. Easton, W. D. Foulkes, M. Genuardi, M. S. Greenblatt, et al. 2008. Sequence variant classification and reporting: recommendations for improving the interpretation of cancer susceptibility genetic test results. *Hum. Mutat.* 29:1282–1291. <https://doi.org/10.1002/humu.20880>.
  30. Gad, S., I. Bièche, M. Barrois, F. Casilli, C. Dehainault, M. Gauthier-Villars, et al. 2003. Characterisation of a 161 kb deletion extending from the NBR1 to the BRCA1 genes in a French breast-ovarian cancer family. *Hum. Mutat.* 21:654. <https://doi.org/10.1002/humu.9148>.
  31. Brown, M. A., L.-J. Lo, A. Catteau, C. F. Xu, G. J. Lindeman, S. Hodgson, et al. 2002. Germline BRCA1 promoter deletions in UK and Australian familial breast cancer patients: identification of a novel deletion consistent with BRCA1:psiBRCA1 recombination. *Hum. Mutat.* 19:435–442. <https://doi.org/10.1002/humu.10055>.
  32. Steffensen, A. Y., M. Dandanell, L. Jønson, B. Ejlersen, A. M. Gerdes, F. C. Nielsen, et al. 2014. Functional characterization of BRCA1 gene variants by mini-gene splicing assay. *Eur. J. Hum. Genet.* 22:1362–1368. <https://doi.org/10.1038/ejhg.2014.40>.
  33. Sandoval, N., M. Platzer, A. Rosenthal, B. Ejlersen, A. M. Gerdes, F. C. Nielsen, et al. 1999. Characterization of ATM gene mutations in 66 ataxia telangiectasia families. *Hum. Mol. Genet.* 8:69–79.
  34. Telatar, M., S. Teraoka, Z. Wang, H. H. Chun, T. Liang, S. Castellvi-Bel, et al. 1998. Ataxia-telangiectasia: identification and detection of founder-effect mutations in the ATM gene in ethnic populations. *Am. J. Hum. Genet.* 62:86–97. <https://doi.org/10.1086/301673>.
  35. Broeks, A., J. H. Urbanus, A. N. Floore, E. C. Dahler, J. G. Klijn, J. T. Emiel, et al. 2000. ATM-heterozygous germline mutations contribute to breast cancer-susceptibility. *Am. J. Hum. Genet.* 66:494–500.
  36. Goldgar, D. E., S. Healey, J. G. Dowty, E. C. Dahler, J. G. Klijn, J. T. Emiel, et al. 2011. Rare variants in the ATM gene and risk of breast cancer. *Breast Cancer Res.* 13:R73. <https://doi.org/10.1186/bcr2919>.
  37. Prodosmo, A., A. Buffone, M. Mattioni, A. Barnabei, A. Persichetti, A. De Leo, et al. 2016. Detection of ATM germline variants by the p53 mitotic centrosomal localization test in BRCA1/2-negative patients with early-onset breast cancer. *J. Exp. Clin. Cancer Res.* 35:135. <https://doi.org/10.1186/s13046-016-0410-3>.
  38. Renwick, A., D. Thompson, S. Seal, P. Kelly, T. Chagtai, M. Ahmed, et al. 2006. ATM mutations that cause ataxia-telangiectasia are breast cancer susceptibility alleles. *Nat. Genet.* 38:873–875. <https://doi.org/10.1038/ng1837>.
  39. van Os, N. J. H., N. Roeleveld, C. M. R. Weemaes, M. C. Jongmans, G. O. Janssens, A. M. Taylor, et al. 2016. Health risks for ataxia-telangiectasia mutated heterozygotes: a systematic review, meta-analysis and evidence-based guideline. *Clin. Genet.* 90:105–117. <https://doi.org/10.1111/cge.12710>.
  40. Thompson, D., S. Duedal, J. Kirner, L. McGuffog, J. Last, A. Reiman, et al. 2005. Cancer risks and mortality in heterozygous ATM mutation carriers. *J. Natl Cancer Inst.* 97:813–822. <https://doi.org/10.1093/jnci/dji141>.
  41. Bernstein, J. L., S. Teraoka, M. C. Southey, M. A. Jenkins, I. L. Andrulis, J. A. Knight, et al. 2006. Population-based estimates of breast cancer risks associated with ATM gene variants c.7271T>G and c.1066-6T>G (IVS10-6T>G) from the Breast Cancer Family Registry. *Hum. Mutat.* 27:1122–1128. <https://doi.org/10.1002/humu.20415>.
  42. Weischer, M., S. E. Bojesen, C. Ellervik, A. Tybjaerg-Hansen, and B. G. Nordestgaard. 2008. CHEK2\*1100delC genotyping for clinical assessment of breast cancer risk: meta-analyses of 26,000 patient cases and 27,000 controls. *J. Clin. Oncol.* 26:542–548. <https://doi.org/10.1200/JCO.2007.12.5922>.
  43. Cybulski, C., D. Wokołorczyk, A. Jakubowska, T. Huzarski, T. Byrski, J. Gronwald, et al. 2011. Risk of breast cancer in women with a CHEK2 mutation with and without a family history of breast cancer. *J. Clin. Oncol.* 29:3747–3752. <https://doi.org/10.1200/JCO.2010.34.0778>.
  44. Daly, M. B., R. Pilarski, M. Berry, T. Huzarski, T. Byrski, J. Gronwald, et al. 2017. NCCN guidelines insights: genetic/familial high-risk assessment: breast and Ovarian, Version 2.2017. *J. Natl. Compr. Canc. Netw.* 15:9–20.
  45. Antoniou, A. C., S. Casadei, T. Heikkinen, D. Barrowdale, K. Pylkäs, J. Roberts, et al. 2014. Breast-cancer risk in families with mutations in PALB2. N.

Engl. J. Med. 371:497–506 <https://doi.org/10.1056/nejmoa1400382>.

46. Li, J., H. Meeks, B.-J. Feng, S. Healey, H. Thorne, I. Makunin, et al. November 2015. Targeted massively parallel sequencing of a panel of putative breast cancer susceptibility genes in a large cohort of multiple-case breast and ovarian cancer families. *J. Med. Genet.* <https://doi.org/10.1136/jmedgenet-2015-103452>.

## Supporting Information

Additional supporting information may be found in the online version of this article:

**Table S1.** Breast/ovarian cancer families investigated for BRCA1/2 mutations.

**Table S2.** Features of the BRCAX families.

**Table S3.** Mutated cancer tissues LOH.