

Comparative Physiology of Renal Tubular Transport Mechanisms

SCOTT LONG AND GERHARD GIEBISCH

*Department of Physiology, Yale University School
of Medicine, New Haven, Connecticut*

Received September 6, 1979

This manuscript discusses current concepts of glomerular filtration and tubular transport of sodium, water, potassium, and urinary acidification by vertebrate kidneys in a comparative context. Work in mammalian and amphibian nephrons receives major emphasis due to our interest in application of new techniques for investigation of cellular mechanisms; when available, data from other vertebrate classes are discussed.

INTRODUCTION

In this essay we discuss in a comparative context results describing several major renal transport processes at the tubular and cellular level.

The term "comparative" commonly refers to delineation of phylogenetic patterns among vertebrate classes and/or to description of adaptation to environmental change within or between vertebrate species. Available data do not permit complete analysis of either of these aspects of comparative renal physiology. Rather, one finds that investigators interested in cellular and segmental tubular analysis have primarily chosen animals for the ease with which certain questions can be studied (as opposed to any particular interest in the animal as a representative of one vertebrate group or another). One should note the great indebtedness that renal physiologists owe, for example, to amphibian nephrons. Not only are our present views on the basic processes of glomerular filtration and tubular function based on early micropuncture studies of Richards and his associates in amphibian tubules [1]; but certain problems in renal tubular transport physiology can only be approached, at least initially, in the uniquely large amphibian tubule.

On the other hand, recent studies have provided us with much information in vertebrates other than amphibians and mammals, and many powerful approaches to study tubular functions, even on the cellular level, are currently being developed and applied broadly among vertebrate species. For example, isolated perfused nephron preparations are available in amphibians, reptiles, and mammals, combining analysis of transepithelial and cellular components of transport. In response to the growing literature in all vertebrates we have elected a comparative approach to our survey of renal tubular transport mechanisms. After a brief introduction to comparative renal anatomy and physiology and to relevant techniques, we discuss glomerular filtration and then renal tubular handling of sodium, water, potassium, and urinary acidification.

525

Work in the laboratory of Gerhard Giebisch supported by grant AM-17433 from the National Institutes of Arthritis Metabolism and Digestive Diseases.

Address reprint requests to: Gerhard Giebisch, M.D., Department of Physiology, Yale University School of Medicine, 333 Cedar Street, New Haven, CT 06510

Copyright © 1979 by The Yale Journal of Biology and Medicine, Inc.

All rights of reproduction in any form reserved.

COMPARATIVE ANATOMY OF VERTEBRATE NEPHRONS

Comparison of vertebrate nephrons reveals a basic sequence of tubular segments: glomerulus → neck segment → proximal tubule → intermediate segment → distal tubule → collecting tubule and duct system. Figure 1 presents some forms and variants of this pattern in the major vertebrate classes, and Fig. 2, schematic drawings of tubular-vascular relations in the two vertebrate groups most commonly used in renal research, amphibians and mammals. Figure 3 compares the proximal tubule of the canine nephron *in situ* and in dissection with its schematic rendering.

Amphibian and reptilian nephrons exemplify the sequence of tubular segments outlined, whereas in mammals two major modifications occur: lengthening of the intermediate segment to form the so-called loop of Henle, and loss of the neck segment. The avian kidney is unique in possessing nephrons of both types; those nephrons with lengthened intermediate segments are called "mammalian," those without it "reptilian."

Striking differences occur in blood supplies to amphibian and mammalian kidneys. In the latter, total renal blood perfusion is of arterial origin, while in amphibians venous blood delivered from hindlimbs by renal portal veins supplements arterial postglomerular blood.

Evolution of vertebrate renal anatomy appears quite conservative when compared, for example, to evolution of respiratory and cardiovascular systems in vertebrates. Major anatomical changes in vertebrate kidneys separate those of birds and mammals from kidneys of lower vertebrates. These changes include not only the modifications of single nephron anatomy but also, as shown in Fig. 2, a parallel

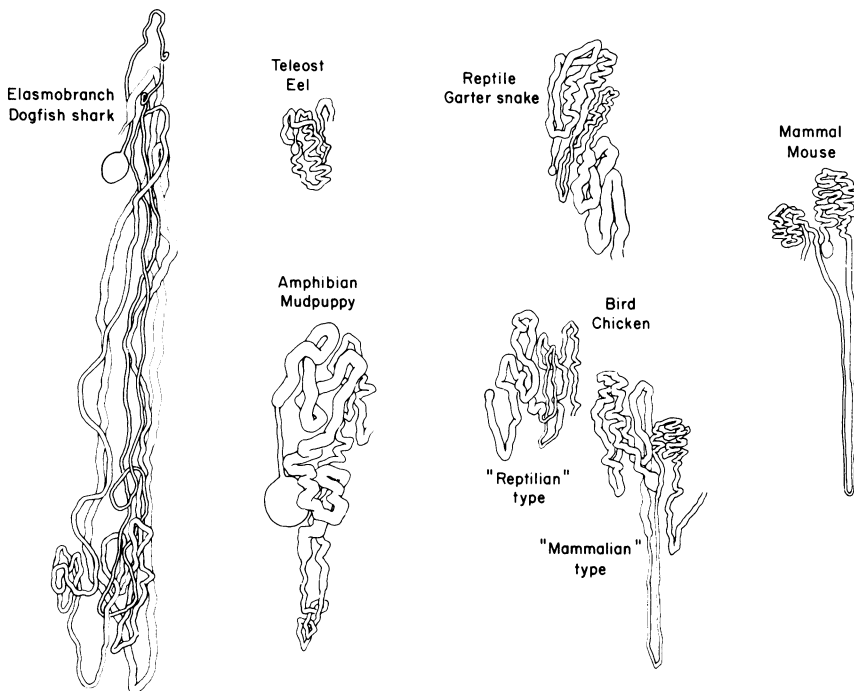

FIG. 1. Schematic representation of six vertebrate nephrons drawn to a single scale. Elasmobranch, *Squalus acanthias* [2]; teleost, *Anguilla rostrata* [3]; amphibian, *Necturus maculosus* [4]; reptile, *Thamnophis sirtalis* [5]; bird, *Gallus domesticus* [6]; mammal, *Mus flavicollis* [7]. Nephrons are presented as specific rather than "representative" examples. Drawing by Virginia Simon, adapted from references given.

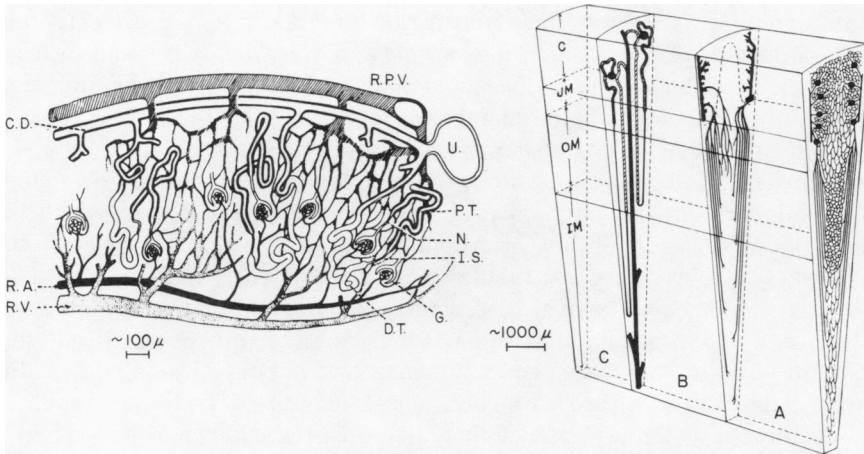

FIG. 2. Simplified drawings of tubular-vascular relations in kidneys of the frog [8] and the rat [9]. Note different scales.

arrangement of Henle's loops, collecting ducts, and accompanying blood vessels, the vasa recta, with consequent division of the kidney into cortical and medullary portions.

Finally, general increase in animal size from fish to mammals is reflected by an increase in total number of nephrons per kidney rather than by consistent change in tubular dimensions. For example, the kidneys of a bullfrog of 0.5 kg contain 1.4×10^4 nephrons, whereas in a human of 70 kg the number is 2×10^6 [11].

GENERAL ASPECTS OF COMPARATIVE
PHYSIOLOGY OF THE NEPHRON

Segmental analysis of tubular functions reveals a common physiological sequence in those vertebrate glomerular nephrons examined. In addition to numerous micro-

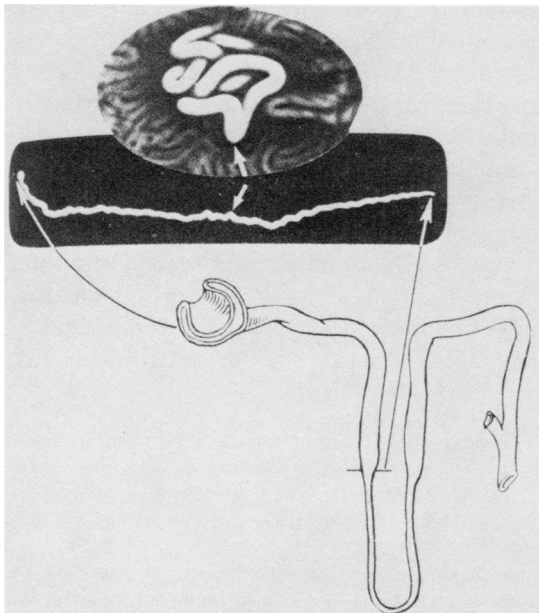

FIG. 3. Proximal tubule of the dog, *in situ* (top), dissected (middle), schematic drawing [10].

puncture experiments in amphibian and mammalian kidneys, reports exist for the lizard *Sceloporus* [12], the elasmobranchs *Raja* and *Squalus* [13,14], and the hagfish [15]. Tubular function in isolated, perfused nephron segments has been investigated in mammals [16], snakes [17], and amphibians [18].

The following sequence of transport function is defined primarily for amphibians and mammals.¹ Glomerular ultrafiltration is followed by more or less extensive proximal tubular isotonic volume reabsorption. The latter is associated with extensive retrieval of sodium chloride, bicarbonate, and other solutes, e.g., glucose and amino acids [20]. Two proximal tubular secretory pathways, one for organic acids and one for organic bases, have also been described, in addition to one for ammonia.

In the distal nephron, acid secretion and hypertonic reabsorption of sodium and water occur in both amphibian and mammalian tubules [21]. Generally, the "distal" nephron, a term loosely used to include the distal tubule, collecting tubule, and collecting ducts, is a "tighter" epithelium than more proximal nephron segments, i.e., the proximal tubule and Henle's loop. In embryological terms, collecting tubules and ducts are not part of the nephron proper but derive from the ureteral bud. The distal nephron maintains higher transepithelial concentration gradients for water, sodium, chloride, and protons, a higher transepithelial electrical potential difference (lumen-negative), a higher transepithelial electrical resistance, and a lower L_p (hydraulic conductivity coefficient). Extensive junctional complexes between distal tubular cells are morphological expressions of such epithelial "tightness" [22].

Certain differences of tubular transport functions between amphibian and mammalian nephrons should be noted. For instance, significant acidification of proximal tubular fluid can be demonstrated in some (but not all) mammalian nephrons [23], but appears to be absent in frogs and *Necturus* (mud puppy) [24]. Potassium ions are extensively reabsorbed along proximal nephrons of mammalian species but not in *Amphiuma* (congo eel) [25].

However, these transport functions show a large margin of adaptation. Net potassium reabsorption can be induced in mammalian distal tubules by dietary potassium deprivation [26], and potassium secretion induced in distal tubules of *Amphiuma* by elevation of plasma potassium or after administration of Diamox [25]. Other functional adaptations concern accentuation of acid and ammonia secretion in proximal tubules of acidotic dogs [27] and rats [28]. Conversely, cortical collecting tubules, taken from rabbits rendered alkalotic and perfused *in vitro*, while normally acidifying, secrete bicarbonate into tubular perfusate [29].

Finally, vertebrate nephrons show significant functional (and fine structural) heterogeneity along and within the major tubular segments [30]. For example, characteristic transport rates for glucose, amino acids, bicarbonate, and phosphate decline along the proximal convoluted tubule. Fluid and sodium reabsorption are significantly smaller in straight segments than in convolutions of mammalian proximal tubules. In contrast, para-aminohippurate transport is more powerful in later portions of proximal tubules of mammals and snakes than in the earlier [31,18].

¹Similarities of "the" vertebrate nephron, as judged by studies in mammals and amphibians, are probably overemphasized by predominant experimental use of these two classes. In both, tubular epithelium acts throughout the nephrons' lengths upon what, in most species, is predominantly a single (liquid) phase. In contrast, in uricotelic birds and reptiles the low solubility of uric acid and urates creates a two-phase (solid and liquid) tubular fluid with possibly important consequences for reabsorption of electrolyte and water handling [19].

Furthermore, in this essay we differentiate only between "mammalian" and "amphibian" models of the nephron. We do not intend to deny or diminish the importance of differences that undoubtedly exist in various aspects of renal tubular transport within each of these two classes.

Different passive permeability properties, e.g., for chloride and bicarbonate, distinguish convoluted from straight portions of mammalian proximal tubules [20].

Nephrons also show heterogeneity with regard to electrical properties [32]. In proximal tubules of rats, reversal of lumen-negative potentials from early to lumen-positive potentials in late proximal tubules is thought to be the result of early proximal preferential bicarbonate reabsorption and consequent establishment of sizable gradients for chloride favoring its diffusive loss across the tubule [23]. By contrast, those species (e.g., *Necturus* [33]) which show equal reabsorption of chloride and bicarbonate along the proximal tubule, maintain significant electro-negativity along the entire proximal tubular length.

Functional heterogeneity is also present along the distal tubule, morphologically a transitional tubular segment made up of several different cell types. In both mammalian and amphibian distal tubules, the earliest portion shows low, vasopressin-unresponsive water permeabilities and positive transepithelial potential differences [18,34]. In later parts of the distal tubule, the electrical potential reverses its sign to become sharply negative. The second half of distal tubules in mammals is the main site of potassium secretion, reabsorbs sodium actively, and can respond to vasopressin with increased water permeability.

TECHNIQUES AVAILABLE FOR EVALUATION OF TUBULAR FUNCTIONS

Figure 4 provides an overview of various techniques used to study renal function. Ease of use in different species varies, although almost all techniques can be employed now regardless of nephron or cell size.

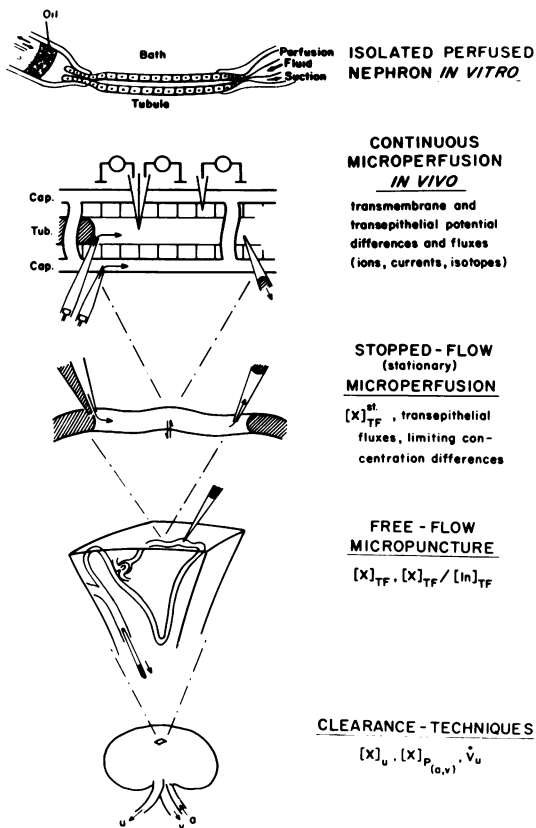

FIG. 4. Techniques for evaluation of renal function. V_{μ} = urinary flow rate; (X) = concentration of substance X in urine (U), arterial and venous plasma ($P_{a,v}$) and tubular fluid (TF); (In) = concentration of inulin [35].

Clearance methods provide overall information on the rate of excretion of a substance relative to its rate of filtration. Minimal rates of net reabsorption and net secretion can be assessed as well as the effect of many stimuli on these functions. This method provides little information on transport properties of individual nephron segments. Despite this limitation, however, many basic aspects of renal transport have been developed by this approach.

Free-flow micropuncture techniques have been used extensively to determine sites of concentration gradients and of transport of solutes and water. Most nephron segments are available for puncture in the amphibian kidney, but only parts of proximal and distal tubules of superficial nephrons and the tip of the exposed papilla can be punctured in mammalian species.

Stopped-flow microperfusion, first developed in the amphibian kidney [36] and later used in mammalian tubules [37], allows the investigator to control composition of luminal fluid more extensively than possible in free-flow studies. Furthermore, this method permits expression of transport processes in terms of surface area exposed per unit time. Finally, limiting concentration differences can be measured when, for instance, appropriate and initially electrolyte-free test solutions are used. This information can be used to assess "pump and leak" properties at various tubular sites [38].

Continuous microperfusion *in vivo*, either alone or in conjunction with perfusion of peritubular capillaries, provides an even greater range of freedom in altering composition of both luminal or peritubular environments; and many groups have used the greater control possible with this technique to measure transepithelial potential differences and transmembrane potentials of single cells. Development of ion-sensitive microelectrodes has made it possible to measure intracellular ion activities and then define accurately electrochemical driving forces acting to move individual solutes across tubular membranes [39]. Most of these latter studies are easier to carry out in amphibian nephrons, but considerable progress has been made toward similar work in mammalian nephrons.

Finally, as shown at the top of Fig. 4, it is possible to dissect out single nephrons and carry out perfusion *in vitro*. Most data by this approach have been obtained in rabbits [40], but other species have also been used [17,18]. The main advantages of the single isolated perfused tubule are availability of all nephron segments for study, easy alteration of luminal and peritubular environments, and access to the cellular compartment of perfused tubules for chemical analysis. Many aspects of transport properties of Henle's loops and collecting tubules are exclusively based on such *in vitro* studies, e.g., demonstration of active chloride transport along the thick ascending limb of the loop of Henle [34].

GLOMERULAR FILTRATION

The first unequivocal demonstration of filtration's role in urine production was characterization of glomerular fluid, withdrawn from individual glomeruli of frogs and *Necturus* by micropuncture, as an ultrafiltrate of plasma [41]. Similar techniques, again applied in amphibians, permitted the first direct assessment of hydrostatic driving forces in glomerular filtration [42,43]. These studies provided a basic framework for the filtration theory, but its transfer and elaboration in mammals was hindered for decades by absence of species with superficial glomeruli suitable for micropuncture studies. Finally, it was found that the retarded growth of the renal cortex in a mutant strain of rats (Munich-Wistar) exposed glomeruli for pressure measurements (arterioles, glomerular capillaries, Bowman's space) and fluid

removal (arterioles, Bowman's space). Hence, one could measure postglomerular, i.e., efferent arteriolar, colloid osmotic pressure [44], and compare its values with the directly measured hydrostatic pressure difference across glomerular capillaries. With measurement of single nephron glomerular filtration rate (SNGFR), these determinations allowed calculation of the filtration coefficient, i.e., the hydraulic conductivity coefficient, of the glomerular membrane in accord with the formula, $SNGFR = K_f(\Delta P - \Delta \pi)$.²

Work in several laboratories has produced information, not only on values of SNGFR, K_f , ΔP and $\Delta \pi$, but has also provided valuable insight into the mechanisms by which plasma volume expansion, hydrostatic pressure changes, changes in blood oncotic pressure, and a variety of hormones affect the process of filtration formation. We have learned from these studies that filtration equilibrium may, under certain conditions, occur prior to the end of glomerular capillaries. Brenner and his associates, in particular, have pointed out that this feature would make the process of filtrate formation sensitive to variations in plasma flow. The filtration coefficient of glomerular membranes is quite large compared to its values in capillaries in other tissues [44], so that relatively small changes in the net driving force across the glomerular capillary membrane can exert significant changes in filtration rate. Recent evidence suggests that several vasodilatory hormones, as well as absolute plasma protein concentration, affect the filtration coefficient directly rather than, as previously thought, by changing the hydrostatic pressure gradient across the glomerular capillary membrane [45].

B.E. Persson has recently studied determinants of SNGFR in an amphibian kidney (*Amphiuma*) [46]. Despite much lower arterial blood pressure (5–25 mm Hg) in amphibians than in mammals (80–120 mm Hg), glomerular filtration in both classes shares several characteristic features. In *Amphiuma*, filtration equilibrium is also reached within the glomerular capillary, as shown by the equality of the colloid osmotic pressure of efferent arteriolar plasma and the hydrostatic gradient across glomerular capillaries. Secondly, Persson described a tubulo-glomerular feedback mechanism in which increased distal flow reduces SNGFR, primarily through an unidentified signal affecting arteriolar tonus. However, unlike the situation in mammals [47], autoregulation of SNGFR was not observed at normal blood pressures in their amphibian preparation; at very low pressures, arteriolar resistance did decrease, to permit sustained capillary flow and filtration.

Hydrostatic pressure in glomerular capillaries of *Amphiuma* varied with colloid osmotic pressure in the glomerular circulation. The driving force for filtration, i.e., the net glomerular capillary pressure, decreased with increasing protein concentration, whereas oncotic dilution effected enhanced filtration by increasing hydrostatic pressure in glomerular capillaries. Since different degrees of hydration induce marked changes in glomerular filtration rate in amphibians [48], one may postulate that the plasma colloid concentration is the means by which filtration rate is varied. However, the studies in *Amphiuma* did not examine the role of antidiuretic hormone in modulation of SNGFR. The mechanism by which changes in glomerular arteriolar resistance are mediated is presently unresolved.

The role of glomerular filtration in volume control of extracellular fluid differs markedly in lower and higher vertebrates. In the latter, birds and mammals,

² ΔP = hydrostatic pressure gradient between glomerular capillary and Bowman's space; $\Delta \pi$ = difference of oncotic pressures of blood perfusing glomerular capillary and that of glomerular filtrate (which last is assumed to be zero); K_f = product of hydraulic conductivity coefficient (k) of glomerular membrane and the surface area (S) across which filtration occurs [44].

extracellular volume is rather closely controlled, primarily by the kidney. GFR is nearly constant, and tubular reabsorption of water regulates the filtered volume excreted. In lower vertebrates, GFR is by no means constant, even in those groups, like stenohaline fish, with relatively constant extracellular volume, and in the terrestrial species which tolerate sizable reductions in body water during dehydration, glomerular filtration may fall to insignificant values. Thus, in fish, amphibians, and reptiles, renal contribution to extracellular volume control consists of variable or intermittent glomerular filtration and of a tubular volume reabsorption reduced and far less variable than that found in birds and mammals (The renal portal veins meet the nutritional and metabolic needs of those kidneys during glomerular shutdown.) In part, the countercurrent systems of the mammalian and avian medullae account for the greater degree of tubular water reabsorption, and antidiuretic hormonal modulation of epithelial water permeability for its variability, at least in mammals. Generally, antidiuretic hormones appear to impinge in higher and lower vertebrates upon the more variable component of renal control of extracellular volume, i.e., on tubular permeability to water in mammals and on glomerular filtration in fish, amphibians, and reptiles. The pattern is not quite so neat in that antidiuretic hormones have been reported to affect both GFR and tubular water reabsorption in birds, to have some tubular effects in amphibians, and to produce both glomerular antidiuresis and diuresis in fish [49].

Finally, attention should be drawn to the fact that significant differences have been noted in rates of filtrate formation between superficial, cortical nephrons and deep, juxtamedullary nephrons of mammals [50]. Thus, SNGFR of juxtamedullary nephrons generally exceeds that of their cortical counterparts. Some evidence of similar distinctions between the "reptilian" and "mammalian" nephrons of the avian kidney exists; SNGFR in the former population is more drastically curtailed by exogenous antidiuretic hormone or salt-loading [51,52]. The question of such differences in filtrate formation by nephron populations in the amphibian kidney is totally unexplored.

Fluid and sodium chloride transport

Early micropuncture studies have clearly shown that quantitative differences exist regarding the extent to which fluid is reabsorbed along different nephron segments. Whereas some 60–75 percent of filtered fluid is retrieved from proximal convoluted tubules of rats, only about one-third to one-half of the filtrate is reabsorbed along proximal tubules of amphibian kidneys examined. Amphibians reabsorb a greater percentage of filtrate volume in the distal tubule than do mammals [53].

Early clearance studies in dogs undergoing strong mannitol diuresis suggested the active nature of proximal sodium transport and the osmotic coupling of water movement to sodium transport, i.e., its passive nature [54]. Subsequent experiments on single amphibian tubules elucidated this process [55]. First, perfusion experiments in single proximal tubules of *Necturus* showed that progressive replacement of sodium chloride in luminal fluid by poorly reabsorbable solutes, like mannitol, led to stepwise reduction of transepithelial water movement despite the isosmotic character of the luminal fluid remaining. These experiments demonstrated the isosmotic character of proximal tubular fluid reabsorption, the dependence of fluid reabsorption upon luminal sodium concentration, and the ability of proximal tubules to generate significant transepithelial sodium concentration gradients. Since the latter were established in the presence of a sizable, lumen-negative transepithelial electrical potential difference, these experiments established unequivocally the active nature of

proximal tubular sodium transport. Following these fundamental studies on amphibian tubules, similar experiments in mammals fully confirmed these findings in that vertebrate class as well [56].

Recently, Dantzler and Bentley have reported an apparent exception to this generality; in isolated perfused proximal tubules from the garter snake they report isotonic reabsorption from sodium-free luminal solutions [57].

As pointed out above, one of the great advantages of many amphibian nephrons is the relatively large size of proximal tubular cells. This has allowed impalement of single tubular cells in *Necturus*, frog, and *Amphiuma* with microelectrodes, and recording of stable electrochemical potential differences across both luminal and peritubular cell membranes of single cells.

Development of ion-sensitive microelectrodes and their application to study electrolyte transport in amphibian nephrons has been a major advance and crucial in elucidating transport of several ion species across various segments of the renal tubular epithelium. Such studies are largely confined to amphibian tubules, but some very recent studies have demonstrated the possibility of extending such work to mammalian nephrons [58].

Figure 5 shows a model of a proximal tubular cell derived from studies of sodium chloride transport across proximal tubules of *Necturus* [59]. Essentially, chemical and electrical potential differences across luminal and peritubular membranes were measured during a series of ion substitutions in luminal and peritubular fluids. The following were the most important conclusions: (1) The proximal tubular cell is electrically negative with respect to both luminal and peritubular fluids. The proximal tubular epithelium has a low electrical resistance due to a high-conductance extracellular pathway that links luminal and peritubular fluid compartments and so shunts the high resistance pathways across the cell membranes [60]. (2) When extracellular sodium is lowered in both luminal and peritubular fluids, a curvilinear relation, indicative of saturation kinetics, describes net transepithelial sodium transport as a function of extracellular sodium concentration. In contrast, when cellular sodium concentration is related to net sodium movement across the proximal

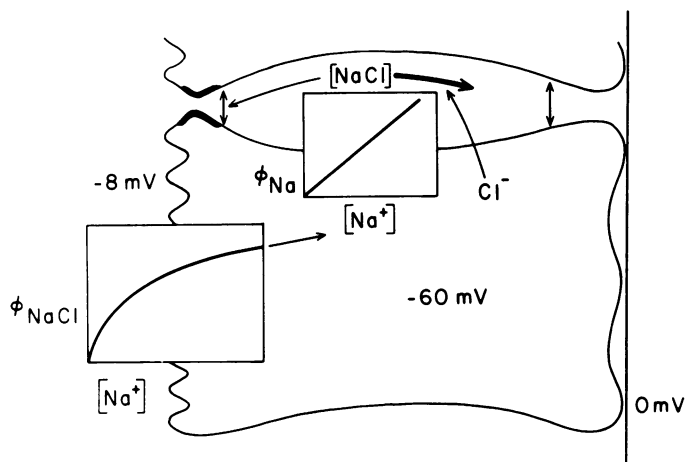

FIG. 5. Model of sodium chloride transport in proximal tubular cell of *Necturus*. Inserts: $NaCl$ transport (ϕ_{NaCl}) as a function of (Na) across luminal membrane (at left) and across basolateral membrane [62].

tubular epithelium, a linear relationship obtains [60]. (3) Addition of amphotericin B, increasing sharply the ionic permeability of the apical cell membrane, further augments cell sodium above control levels and produces a proportional increase in net sodium transport [60].

The conclusions drawn from such studies have led to successful application of the double-membrane model to proximal tubular sodium chloride transport [61]. The basolateral cell membrane emerges as the site of an active sodium pump that maintains its unsaturated character over a concentration range exceeding normal cellular sodium concentrations. The luminal cell membrane normally limits sodium transport, and the saturable character of overall sodium reabsorption is the consequence of the decline of sodium permeability of the luminal cell membrane with increasing cell sodium concentrations. Finally, it was demonstrated that a significant fraction of sodium entry into tubular cells depends on the presence of chloride in the tubular lumen [62]. Thus, it is postulated that sodium chloride enters the cell from the lumen electroneutrally by a carrier mechanism, driven by the activity gradient of sodium across the luminal brush border membranes. Similar studies have not yet been made with mammalian membranes.

Electrophysiology

As pointed out above, electrical characterization of renal tubular cells has largely been dependent upon potential and resistance measurements in amphibian nephrons, where large cell size permits stable impalement with both single and double-barrel microelectrodes. Such measurements of electrical properties of membranes and cytoplasm, and of intracellular ionic activities, are all necessary to define the transmembrane electrochemical driving forces acting on individual ions. The most important results are summarized in Fig. 6, showing the equivalent circuit of a proximal tubular cell, based on data obtained in *Necturus* [63].

The electrical potential across the whole renal epithelium is composed of two potential steps, each being generated by passive and active (energy-dependent) components. E_1 and E_2 represent ionic batteries, i.e., ionic concentration differences responsible for diffusion potentials across the luminal (E_2) and peritubular (E_1) membranes. R_1 and R_2 are ionic resistances. R_1 , the peritubular membrane resistance, is largely a potassium-selective resistance element; such characterization of the

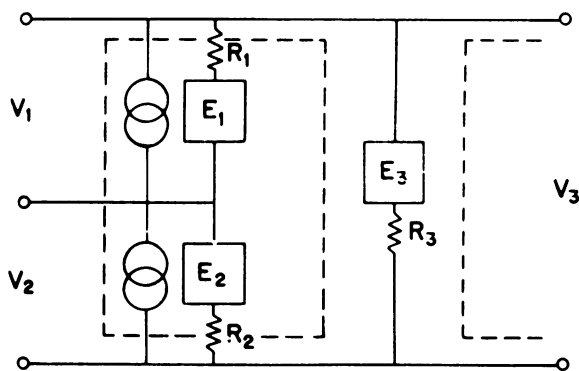

FIG. 6. Electrical equivalent circuit for proximal tubular cell. V_1 and V_2 = potential differences across peritubular and luminal cell membranes, respectively; V_3 = transepithelial potential difference; other elements defined in text. Dashed lines represent cell borders [63].

luminal membrane is less clearly defined. In addition to these passive elements generating potential differences across the luminal cell membrane, direct current-generating mechanisms (electrogenic or rheogenic pumps) are also present. These are symbolized by the circular symbols and are likely to involve a sodium pumping mechanism which does not exchange with other ions (mostly potassium) at an exchange ratio of 1:1 [63].

Experiments in amphibian nephrons have also been the first to draw attention to the presence of a significant intercellular shunt (E_3, R_3) between luminal and peritubular compartments. From a functional standpoint, this is of major importance because it is now recognized that (1) the overall permeability of the proximal tubular epithelium depends largely on the permeability properties of the low-resistance intercellular pathway, and (2) that solute-solvent coupling, which represents a functional linkage between active sodium transport and osmotically coupled water movement, involves the intercellular space [64]. The permeability of the intercellular shunt pathway imposes on the nephron a "leaky" or "tight" character, descending from the low-resistance proximal tubule to the relatively high resistance collecting tubule [22].

Thus, we owe to these electrophysiological studies on single amphibian tubules, mostly *Necturus* and *Amphiuma*, our present conceptions of the nephron's electrophysiological properties. Similar to other areas, more recent studies on single mammalian tubules, in which cellular impalements are possible but technically much more demanding, have been carried out and fully confirmed many of the conclusions based on results obtained in amphibian tubules [65].

RENAL TUBULAR POTASSIUM TRANSPORT

Despite extensive studies of potassium transport in the mammalian nephron, much less is known about its mode of renal transport in lower vertebrates. Interest in the renal regulation of potassium began with the early recognition that in the mammalian nephron potassium ions, after their filtration, are both reabsorbed and secreted by the renal tubule [66].

An extensive series of micropuncture studies in the nephron of the rat has helped to clarify the nephron sites and some of the cellular mechanisms of potassium transport [25]. Earlier evidence was confirmed in that most filtered potassium is reabsorbed during flow along the proximal tubule and along Henle's loop, and that variable potassium secretion along the distal tubules and the cortical collecting tubules determines the rate of potassium excretion into the final urine [67]. Thus, the tubular site of renal regulation of potassium is the distal nephron. Most of the factors modulating urinary potassium excretion, e.g., changes in potassium balance, alterations in level of mineralocorticoids, changes in flow rate and sodium delivery, and acid-base changes were shown to be acting on distal nephron secretion [67]. (See Figs. 7 and 8.)

A model of potassium transport, taking into account cellular electrical potential and potassium activity measurements, was developed. Again, it contains data obtained in mammalian nephrons, as far as net transport is concerned, but includes some information, particularly that on cell potentials and activities, originating from experiments in the kidney of *Amphiuma* [25,26]. (The ventral surface of the kidney in this species consists almost entirely of distal tubules, an obvious help in these experiments.)

Less is known about the renal potassium transport system in amphibians. Those species showing extensive potassium conservation, e.g., *Amphiuma*, reabsorb potas-

PATTERN OF FRACTIONAL K^+ EXCRETION IN
SUPERFICIAL NEPHRON IN THE RAT

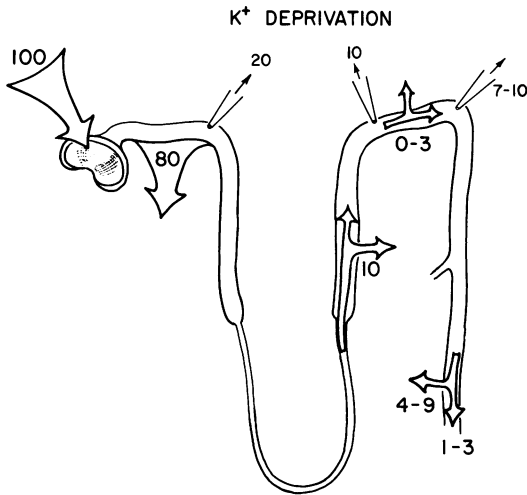

FIG. 7. Tubular sites of potassium transport along a mammalian superficial nephron in animals conserving potassium. Note extensive reabsorption of potassium along the whole nephron.

sium avidly along the distal tubule. It is of interest, though, that potassium secretion can be induced upon raising ambient potassium concentration or by administration of carbonic anhydrase inhibitors [25]. Another feature of those few species examined is the variability of potassium reabsorption along the proximal tubules, either absent or small in *Amphiuma* [25] and *Necturus* [68], but easily demonstrated in the bullfrog [69]. Very little is presently known concerning regulation of potassium transport at the tubular level in non-mammalian species.

Urinary Acidification

Urinary acidification describes those renal processes by which filtered bicarbonate is reabsorbed and excess acid or base excreted. Micropuncture studies in mammals and amphibians have shown that tubular reabsorption of filtered bicarbonate lowers

PATTERN OF FRACTIONAL K^+ EXCRETION IN
SUPERFICIAL NEPHRON IN THE RAT

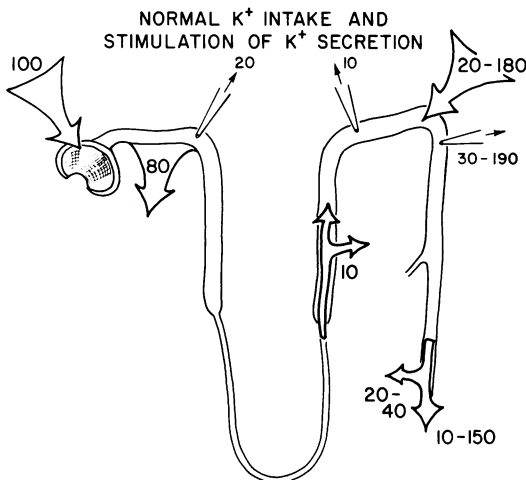

FIG. 8. Tubular sites of potassium transport along a mammalian superficial nephron in animals challenged to excrete variable amounts of potassium. Note extensive reabsorption of potassium along the proximal tubule and Henle's loop and a variably extensive secretion along the distal tubule and collecting ducts. Some reabsorption may follow after distal secretion as indicated by the fact that the amount of potassium in the final urine may be less than that present at the end of the superficial distal tubule.

the pH of tubular fluid which in turn titrates buffers remaining in the tubular fluid and promotes secretion of ammonia.

A. Bicarbonate Reabsorption

The earliest localization of urinary acidification measured pH of tubular fluid in blood- and Ringer's-perfused kidneys of frogs and *Necturus* [24]. As shown in Fig. 9, no pH gradient occurred between proximal tubular fluid and perfusate. Although water reabsorption was not measured in these experiments, subsequent work in amphibian species revealed a proximal (TF/P) inulin ratio of 1.25-1.50 [70,71], so that roughly 20-35 percent of filtered bicarbonate is reabsorbed in the proximal tubule if we assume transtubular equilibration of pCO_2 . A maximal gradient of nearly 1.4 pH units was recorded in the distal tubule and dye injection revealed that a small section, approximately one-fifth of the distal tubule midway along its length, was responsible for titration of dye and concomitant buffer under control conditions [24].

The pattern of tubular acidification, determined by free flow micropuncture studies in rat and Rhesus monkey [72,73], differs distinctly from that of amphibians in that a pH gradient of ~0.7 units is established in the proximal tubule, maintained in the distal and accentuated in the collecting duct, as shown for the rat in Fig. 9. Under control conditions, all portions of the rat nephron show bicarbonate reabsorption; the

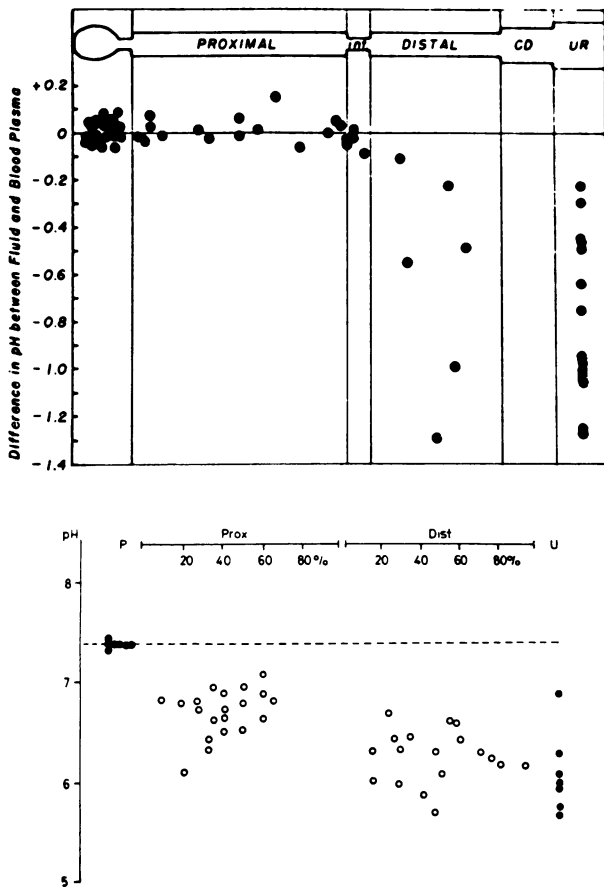

FIG. 9. Sites of tubular acidification in the kidneys of *Necturus* [24] and the rat [72].

proximal tubule is responsible for more than 85 percent of the total, while the final urine contains less than 0.5 percent of the filtered load. In studies taking advantage of desert rodents' long papilla, direct measurement by microcatheterization in collecting ducts of hamsters showed decreasing pH along that segment [74].

The pattern of bicarbonate reabsorption defined in rats and Rhesus monkeys is not constant in all carnivorous mammals, since in dogs, under control conditions, no pH gradient is established in the proximal tubule [75], similar to finding in amphibians. However, induction of acidosis reveals the capacity to acidify proximal tubular fluid in dogs, as noted above [27].

Carbonic anhydrase has often been assigned a predominant role in discussion of cellular mechanisms underlying urinary acidification in mammals. The enzyme accelerates the release of H^+ from water at rates sufficient to account for the rates of epithelial acidification.

Histochemical evidence supports an important role for carbonic anhydrase which is found throughout proximal and distal tubules of rats, monkeys, rabbits, turtles, and toads, as well as an initial segment of the proximal tubule in pigeons [76]. In frogs, carbonic anhydrase is found in all cells of a short segment of the distal tubule but not in proximal tubular cytoplasm [77]. The enzyme has also been found in collecting ducts of all mammals investigated; in some species (rats, dogs) the enzyme appears to occur in all cells, while in others (rabbits, monkeys) in scattered cells [76]. Collecting ducts of frogs and bladders of toads and turtles also show this heterogeneous distribution [77,78].

These histochemical results generally support the conclusion that carbonic anhydrase occurs in those segments and epithelia which reabsorb bicarbonate and lower urinary pH. Similarly, both concentrations of carbonic anhydrase and acidification rates are higher in bladders from Colombian than in Dominican subspecies of *Bufo marinus* [79,80,81]. However, bicarbonate reabsorption does occur without tubular fluid acidification and without carbonic anhydrase, as shown in proximal tubules of *Necturus* and frogs. In this case one must invoke uncatalyzed H^+ secretion and/or reabsorption of ionic bicarbonate.

Unequivocal demonstration of ionic reabsorption of bicarbonate has been difficult. Deetjen and Maren investigated the possibility by stopped-flow microperfusion studies in proximal tubules of the skate *Raja* [13]. Absence of carbonic anhydrase in elasmobranch kidneys [82] suggests that uncatalyzed H^+ secretion and ionic reabsorption of bicarbonate alone account for tubular acidification. Acidification rates in skate proximal tubules were estimated from tubular geometry, the volume of injected fluid, and the time required to titrate bromcresol purple (BCP) from purple to yellow in the presence of two concentrations of $NaHCO_3$ (5 and 12 mM) and of 9 mM phosphate + 12 mM bicarbonate. The time of titration in controls (BCP only) was not affected by the addition of either concentration of bicarbonate but was lengthened by addition of phosphate. The authors concluded that titration of BCP and phosphate occurred by rate-limiting uncatalyzed secretion of H^+ , while decrease in bicarbonate concentration was accounted for by its ionic reabsorption at much higher rates.

Maren has suggested a phylogenetic sequence of cellular mechanisms underlying urinary acidification in vertebrates [83]. Reabsorption of ionic bicarbonate, the older system found in (marine) stenohaline fish, leads to fixed urinary pH resistant to experimental change of the animals' acid-base states, e.g., respiratory acidosis [84]. Maren asserts that this system is quantitatively predominant in most vertebrates and

has been supplemented in more recent vertebrate classes by a system dependent on carbonic anhydrase, endowing those groups with the ability to vary urinary pH.

This simple and attractive hypothesis does not assign any role to renal carbonic anhydrase found in marine teleosts, nor does it offer a unique explanation for fixity of urinary pH in marine fish. Many physiologists would hesitate to assign predominance to ionic transport to account for bicarbonate reabsorption in the mammalian kidney.

B. Acid Excretion

The decrease in tubular fluid pH by whatever means leads to titration of filtered buffers and promotes secretion of ammonia. Absolute values of acid excretion depend upon (i) the buffer load, (ii) the pK's of excreted buffers, and (iii) the systemic acid-base status of the organism with its consequent metabolic changes.

The pronounced effect of diet may affect net acid excretion through all these factors. Carnivorous and omnivorous mammals with an acid ash diet generally excrete a urine with average pH near 6, while average urinary pH in herbivores may rise as high as 8. Dietary change provides striking evidence for flexibility of urinary pH. Calves and sheep produced an alkaline urine (pH 8) on a roughage diet and an acid urine on fish meal concentrate; on the latter diet, daily excretion of ammonia and acid phosphate was nearly ten times that excreted by animals on roughage diets [85]. Changing diet from mealworms to bananas produced similar effects on urinary pH in the lizard, *Dipsosaurus dorsalis* [86].

Table 1 presents a survey of net renal acid excretion in various vertebrate classes. Relatively few species have been thoroughly examined for acid excretion, and no clear trend among the classes is apparent. For carnivorous species, renal acid excretion generally ranges from 10 to 50 uEq acid/hr kg body weight although values for mongrel dogs may be much higher [92]. Fine predictions of urinary pH and acid excretion, even for animals from the same environment, are difficult. For example, another fresh-water teleost from the same region of the Amazon as the Traira excretes an average of 26 uEq/hr kg in a urine of average pH 6.9, both figures significantly different from those in Table 1 [88]. Furthermore, it should be noted that branchial excretion of ammonia and bicarbonate [93] may change considerably the estimates of whole body acid excretion from values listed in the table for both teleosts and elasmobranchs.

The most important distinctions to be made from the literature cited in Table 1 are the fixed urinary pH in marine fish and the flexible urinary pH in terrestrial vertebrates, especially birds and mammals. The role of environment in the former and that of the countercurrent anatomy and function in determining the latter have not been unequivocally defined.

C. Ammonia³

The non-ionic diffusion theory is generally accepted as the basis for renal excretion of ammonia [94,95], and the predicted negative correlation of urinary pH and ammonia concentrations or excretion rates has been observed in clearance studies in control and experimental states in rats [96], dogs [97], sheep [98], chickens [90], alligators [89], frogs [99], toads [88], and fresh water teleosts [87].

Segmental analysis of ammonia secretion has so far been confined to amphibians

³Ammonia refers to both ionized (NH_4^+) and un-ionized (NH_3) forms of the buffer pair; use of the chemical formulation in the text specifies solely that form.

TABLE I
 Acid excretion rates among vertebrates

Organism	pH _u	uEq/hr kg body weight				Av. body weight Kg	T °C	Ref.
		E _{TA}	E _{NH₄⁺}	E _{HCO₃⁻}	E _{H⁺}			
dogfish shark <i>Squalus acanthias</i>	5.8	31	0.3	~ 0	+31	2.8	13	[84]
traira <i>Hoplias malabaricus</i>	5.7	~ 13	35	0	+48	0.5	30	[87]
toad <i>Bufo marinus</i>	7.0	9*	87	60	+36	0.2	22	[88]
alligator <i>A. mississippiensis</i>	7.8	2*	74	~ 50	~ +26	5	22	[89]
chicken <i>Gallus domesticus</i>	6.9	74	53	~ 137	~ +10	2.5	(41.5)	[90]
subject P <i>Homo sapiens</i>	6	12	25	0	+37	(70)	37	[91]
cow <i>Bos sp.</i>								
roughage diet	7.1-8.4	trace	6-30	19-65	-6 to -57	105	(37)	[85]
fishmeal diet	5.4-6.6	17-71	12-68	0	+13 to +102	105	(37)	[85]

The values represent averages quoted or derived from references cited and are intended here as specific to the organisms listed rather than representative of a vertebrate class. Starred values (*) for titratable acidity represent only urinary [H₂PO₄⁻]. In some cases, values for body weight (man), for body temperature (cow and chicken) and pK's for carbon dioxide bicarbonate and for phosphate buffer systems have been assumed. pH_u = urinary pH; E_{TA}, E_{NH₄⁺}, E_{HCO₃⁻}, E_{H⁺} = excretion rates of titratable acidity, ammonium, bicarbonate, and acid, respectively.

and mammals. In frogs and *Necturus*, Walker detected ammonia only in urine from distal tubules and collecting ducts [100], although his method for ammonia determination was sensitive only for concentrations above 0.7 mM, as Goldstein points out [95]. In rats, ammonia secretion is evenly divided between proximal tubule and distal nephron [101]. Microcatheterization experiments in collecting ducts of golden hamster [102] (also a site of acidification [74]) reveal a stronger secretion of ammonia than in rats, consonant with the relative concentrations of glutaminase in the two species [75]. In these studies the sites of ammonia secretion and of tubular fluid acidification coincide.

In normal acid-base status the dog neither secretes ammonia nor lowers pH of proximal tubular fluid [27,75]. When the dog is subjected to chronic metabolic acidosis by ingestion of NH₄Cl, the proximal tubule both acidifies and secretes ammonia into the tubular fluid of that segment, but acute metabolic acidosis produces acidification of proximal tubular fluid without ammonia secretion [27], an observation which stresses the metabolic components of ammonia excretion.

The effects of the corticomedullary gradient and of antidiuretic hormone on interpretation of clearance studies of ammonia handling by the mammalian kidney are not well defined. Gottschalk and his collaborators have hypothesized that medullary extraction of water may alkalize tubular fluid in the descending limb of Henle's loop and so release into the medullary interstitium NH₃ which then diffuses into the acidic tubular fluid of the collecting duct [103].

SUMMARY

In this essay we have attempted a comparative perspective on renal tubular transport. The more common and successful comparisons of transport mechanisms have concerned amphibians and mammals. The bases for this common comparison are, first, the greater ease with which amphibian renal anatomy lends itself to experimentation at the cellular level, and, second, man's interest in his own vertebrate class. As we have seen, the fewer data obtained for a given system in mammals often accord with a more extensive description in amphibians, so that overall similarity of the system in the two classes is stressed at this level of analysis. Furthermore, experimentally induced adaptation often reveals an underlying similarity of cellular transport mechanisms, even when initial description has stressed the differences between amphibians and mammals.

One cannot at present delineate a phylogenetic sequence for any given transport system since relatively few species have been examined at the cellular level in any vertebrate class. Nonetheless, we hope that this essay will serve to provoke readers to consider both the conceptual and descriptive rewards to be gained in expanding the newer, powerful methods of transport analysis to continued investigation of both "old" and "new" species.

REFERENCES

1. Richards A: Urine formation in the amphibian kidney. Harvey Lectures 93-118, 1934-35
2. Kempton RT: Studies on the elasmobranch kidney. I. The structure of the renal tubule of the spiny dogfish (*Squalus acanthias*). J Morphol 73:247-263, 1943
3. Grafflin AL: The structure of the nephron in fishes. Anat Record 68:287-303, 1937
4. Kempton RT: The dimensions of the renal tubules of *Necturus maculosus*. J Morphol 61:51-62, 1937
5. Bishop JE: A histological and histochemical study of the kidney tubule of the common garter snake, *Thamnophis sirtalis*. J Morphol 104:307-357, 1959
6. Huber GC: On the morphology of the renal tubules of vertebrates. Anat Rec 13:305-339, 1917
7. Sperber I: Studies on the mammalian kidney. Zool bidrag fran Uppsala 22:249-431, 1944
8. Schmidt-Nielsen BM, McKay WC: Comparative physiology of electrolyte and water regulation, with emphasis on sodium, potassium, chloride, urea and osmotic pressure. Clinical Disorders of Fluid and Electrolyte Metabolism. Edited by MH Maxwell, CR Kleeman. New York, McGraw-Hill Book Co, 1972, pp 45-93
9. Kriz W: Organization of structures within the renal medulla. Urea and the Kidney. Edited by B Schmidt-Nielsen. Amsterdam, Excerpta Medica Foundation, 1970, pp 342-357
10. Knox FG: Phosphate transport along the nephron. Amer J Physiol 233:F261-F268, 1977
11. Renkin EM, Gilmore JP: Glomerular filtration. Handbook of Physiology, Section 8: Renal Physiology. Edited by J Orloff, RW Berliner. Baltimore, William & Wilkins Co, 1973, pp 185-248
12. Stolte H, Schmidt-Nielsen B, Davis L: Single nephron function in the kidney of the lizard, *Sceloporus cyanogenys*. Zool Jb Physiol 81:219-244, 1977
13. Deetjen P, Maren TH: The dissociation between renal HCO₃⁻ reabsorption and H⁺ secretion in the skate, *Raja erinacea*. Pflügers Arch ges Physiol 346:25-30, 1973
14. Schmidt-Nielsen B, Ullrich KJ, Rumrich G, et al: Micropuncture studies of urea movement across the renal tubules of *Squalus acanthias*. Bull Mt Desert Isl biol Lab 6:35, 1966
15. Stolte H, Eisenbach GM: Single nephron filtration rate in the hagfish, *Myxine glutinosa*. Bull Mt Desert Isl biol Lab 13:120-121, 1973
16. Burg MG, Orloff J: Perfusion of isolated renal tubules. Handbook of Physiology. Edited by J Orloff, RW Berliner. Baltimore, William & Wilkins Co, 1973, pp 145-160
17. Dantzler WH: PAH transport by snake proximal renal tubules: Differences from urate transport. Amer J Physiol 226:634-641, 1974
18. Stoner LC: Isolated, perfused amphibian renal tubules: The diluting segment. Amer J Physiol 233:F438-F444, 1977
19. Dantzler WH: Urate excretion in nonmammalian vertebrates. Handbook of Experimental Pharmacology, Vol 51. Edited by GVR Born, A Farah, AD Welch. Berlin, Springer-Verlag, 1978, pp 185-210
20. Giebisch G: The proximal nephron. Physiology of Membrane Disorders. Edited by TE Andreoli, JF Hoffman, DD Fanestil. New York, Plenum Press, 1978, pp 629-660

21. Windhager EE, Costanzo LS: Transport functions of the distal convoluted tubule. *Physiology of Membrane Disorders*. Edited by TE Andreoli, JF Hoffman, DD Fanestil. New York-London, Plenum Press, 1978, pp 681-706
22. Erljij D, Martinez-Palomo A: Role of tight junctions in epithelial function. *Membrane Transport in Biology*. III. Transport across multi-membrane system. Edited by G Giebisch. Berlin, Springer-Verlag, 1978, pp 27-53
23. Gottschalk CW: Renal tubular function: Lessons from micropuncture. *Harvey Lecture Ser* 58:99-123, 1963
24. Montgomery H, Pierce JA: The site of acidification of the urine within the renal tubule of amphibia. *Amer J Physiol* 118:144-152, 1937
25. Wiederholt M, Sullivan WJ, Giebisch G, et al: Transport of potassium and sodium across single distal tubules of *Amphiuma*. *J Gen Physiol* 57:495-529, 1971
26. Giebisch G: Renal potassium transport. *Membrane Transport in Biology*. IVA. Transport organs. Edited by G Giebisch. Berlin, Springer-Verlag, 1979, pp 215-298
27. Clapp JR, Owen EE, Robinson RR: Contribution of the proximal tubule of urinary ammonia excretion by the dog. *Amer J Physiol* 209:269-272, 1964
28. Glabman S, Klose RM, Giebisch G: Micropuncture study of ammonia excretion in the rat. *Amer J Physiol* 205:127-132, 1963
29. McKinney TD, Burg MB: Bicarbonate transport by rabbit cortical collecting tubules. Effect of acid and alkali *in vivo* on transport *in vitro*. *J Clin Invest* 60:766-768, 1977
30. Valtin H: Structural and functional heterogeneity of mammalian nephrons. *Amer J Physiol* 233:F491-F501, 1977
31. Tune BM, Burg MB, Patlak CS: Characteristics of p-aminohippurate transport in proximal renal tubules. *Amer J Physiol* 217:1057-1063, 1969
32. Boulpaep EL: Recent advances in electrophysiology of the nephron. *Ann Rev Physiol* 38:20-36, 1976
33. Giebisch G: Measurement of pH, chloride and inulin concentrations in proximal tubule fluid of *Necturus*. *Amer J Physiol* 185:171-175, 1956
34. Burg M, Stoner L: Renal tubular chloride transport and the mode of action of some diuretics. *Ann Rev Physiol* 38:37-45, 1976
35. Giebisch G: Micropuncture techniques. *Transport of Ions and Water in Animals*. Edited by BL Gupta, RM Moreton, JL Oschman, BJ Wall. London, Academic Press, 1977, pp 29-56
36. Shipp JC, Hanenson IB, Windhager EE, et al: Single proximal tubules of the *Necturus* kidney: Methods for micropuncture and microperfusion. *Amer J Physiol* 195:563-569, 1958
37. Gertz KH: Transtubuläre Natrium-chloridflüsse und Permeabilität für Nichtelectrolyte im proximalen und distalen Konvolut der Rattenniere. *Pflügers Arch ges Physiol* 276:336-356, 1963
38. Giebisch G, Windhager EE: Electrolyte transport across renal tubular membranes. *Handbook of Physiology*, Section 8, Renal Physiology. Edited by J Orloff, RW Berliner. Baltimore, William & Wilkins Co, 1973, pp 315-376
39. Boulpaep EL, Giebisch G: Electrophysiological measurements on the renal tubule. *Methods in Pharmacology*, Volume 4B. Edited by M Martinez-Maldonado. New York, Plenum Press, 1979, pp 165-193
40. Chonko AM, Irish JM III, Welling DJ: Microperfusion of isolated tubules. *Methods in Pharmacology*, Vol 4B. Edited by M. Martinez-Maldonado. New York, Plenum Press, 1978, pp 221-258
41. Wearn J, Richards A: Observation on the composition of glomerular urine, with particular reference to the problem of reabsorption in the renal tubules. *Amer J Physiol* 71:209-227, 1924
42. Hayman JM Jr: Estimation of afferent arteriole and glomerular capillary pressures in frog kidney. *Amer J Physiol* 79:389-409, 1927
43. White HL: Observation on the nature of glomerular activity. *Amer J Physiol* 90:689-704, 1929
44. Brenner BM, Deen WM, Robertson CR: Glomerular filtration. *The Kidney*, Vol 1. Edited by BM Brenner, FC Rector, Jr. Philadelphia, WB Saunders Co, 1976, pp 251-271
45. Brenner BM, Baylis C, Ichikawa I, et al: Dynamics of glomerular ultrafiltration: Insights from micropuncture. *Renal Function*. Edited by GH Giebisch, EF Purcell. New York, Josiah Macy, Jr Foundation, 1977, pp 23-40
46. Persson BE: Dynamics and regulation of the glomerular filtration rate in the *Amphiuma* kidney. Dissertation, University of Uppsala, 1978
47. Thureau K, Schnermann J: Die Natrium Konzentration an der Macula densa-Zellen als regulierender Faktor für das Glomerulumfiltrat. *Klin Wschr* 43:410-413, 1965
48. Schmidt-Nielsen B, Forster RP: The effect of dehydration and low temperature on renal function in the bullfrog. *J Cell Comp Physiol* 44:233-246, 1954
49. Holmes WN, Pearce RB: Hormones and osmoregulation in the vertebrates. *Mechanisms of Osmoregulation in Animals*. Edited by R Gilles. Chichester, John Wiley & Sons, 1979, pp 413-533
50. de Rouffignac C, Bonvalet JP: Heterogeneity of nephron population. *MTP International Review of Science*. Vol 6. *Kidney and urinary tract physiology*. Edited by K Thureau. Baltimore, University Park Press, 1974, pp 391-409
51. Braun E, Dantzer WH: Effects of ADH on single nephron glomerular filtration rates in the avian kidney. *Amer J Physiol* 226:1-8, 1974
52. Braun EJ: Intrarenal blood flow distribution in the desert quail following salt loading. *Amer J Physiol* 231:1111-1118, 1976

53. Giebisch G: Some transport properties of amphibian and mammalian nephrons. *Comparative Physiology*. Edited by L. Bolis, K. Schmidt-Nielsen, SMP Maddrell. Amsterdam, North-Holland Publishing Co, 1973, pp 241–291
54. Wesson LG, Anslow WP Jr: Excretion of sodium and water during osmotic diuresis in the dog. *Amer J Physiol* 153:465–474, 1948
55. Windhager E, Whittenburg G, Oken D, et al: Single proximal tubules of the *Necturus* kidney. III. Dependence of H₂O movement of NaCl concentration. *Amer J Physiol* 197: 313–318, 1959
56. Giebisch G, Windhager EE: Renal tubular transfer of sodium, chloride and potassium. *Amer J Med* 36:643–669, 1964
57. Dantzler WH, Bentley SK: Fluid absorption with and without sodium in isolated perfused snake proximal tubules. *Amer J Physiol* 234:F68–F79, 1978
58. Edelman A, Curci S, Samarzija J, et al: Intracellular potassium activity in rat kidney proximal tubular cells. *Pflügers Arch ges Physiol* 378:37–45, 1978
59. Spring K, Giebisch G: Kinetics of Na⁺ transport in *Necturus* proximal tubule. *J Gen Physiol* 70:307–328, 1977
60. Boulpaep E: Electrical phenomena in the nephron. *Kidney Int* 9:88–102, 1976
61. Ussing HH, Zerahn K: Active transport of sodium as a source of electric current in the short-circuit isolated frog skin. *Acta Physiol Scand* 23:110–127, 1951
62. Spring KR, Kimura G: Chloride reabsorption by renal proximal tubules of *Necturus*. *J Mem Biol* 38:233–254, 1978
63. Giebisch G, Boulpaep EL, Whittembury G: Electrolyte transport in kidney tubular cells. *Proc Roy Soc Lond, Series B*, 262:175–196, 1971
64. Sackin H, Boulpaep EL: Models for coupling of salt and water transport: Proximal tubular reabsorption in *Necturus* kidney. *J Gen Physiol* 66:671–733, 1975
65. Frömter E: Solute transport across epithelia: What can we learn from micropuncture studies on kidney tubules? *J Physiol* 288:1–31, 1979
66. Berliner RW: Renal mechanism for potassium excretion. *Harvey Lectures* 55:141–171, 1961
67. Wright FS, Giebisch G: Renal potassium transport: Contributions of individual nephron segments and populations. *Amer J Physiol* 235:F515–F527, 1978
68. Oken DE, Solomon AK: Single proximal tubules of *Necturus* kidney. VI. Nature of potassium transport. *Amer J Physiol* 204:377–380, 1963
69. Fujimoto M, Kubota T, Kotera K: Electrochemical profile of K and Cl ions across the proximal tubule of bullfrog kidneys. *Contr Nephrol* 6:114–123, 1977
70. Bott PA: A micropuncture study of renal excretion of water, K, Na and Cl in *Necturus*. *Amer J Physiol* 203:662–666, 1962
71. Long WS: Renal handling of urea in *Rana catesbeiana*. *Amer J Physiol* 224:482–490, 1973
72. Malnic G, Giebisch G: Mechanism of renal hydrogen ion secretion. *Kidney Int* 1:280–296, 1972
73. Bennett CM, Brenner BM, Berliner RW: Micropuncture study of nephron function in the Rhesus monkey. *J Clin Invest* 47:203–216, 1968
74. Hierholzer K: Secretion of potassium and acidification in collecting ducts of mammalian kidney. *Amer J Physiol* 201:318–324, 1961
75. Bernstein BA, Clapp JR Jr: Micropuncture study of bicarbonate reabsorption by the dog nephron. *Amer J Physiol* 214:251–257, 1968
76. Rosen S: Localization of carbonic anhydrase activity in the vertebrate nephron. *Histochem J* 4:35–48, 1972
77. Lönnerholm G, Ridderstrale Y: Distribution of carbonic anhydrase in the frog nephron. *Acta Physiol Scand* 90:764–778, 1974
78. Rosen S: Localization of carbonic anhydrase in turtle and toad urinary bladder mucosa. *J Histochem Cytochem* 20:696–702, 1972
79. Davies HEF, Martin DG, Sharp GWG: Differences in the physiological characteristics of bladders of toads from different geographical sources. *Biochim Biophys Acta* 150:315–318, 1968
80. Rosen S, Oliver JA, Steinmetz PR: Urinary acidification and carbonic anhydrase distribution in bladders of Dominican and Colombian toads. *J Membr Biol* 15:193–205, 1974
81. Ziegler TW, Ludens JH, Fanestil DD: Role of carbonic anhydrase in urinary acidification by the toad bladder. *Amer J Physiol* 227:1132–1138, 1974
82. Maren TH: Carbonic anhydrase: Chemistry, physiology and inhibition. *Physiol Rev* 47:595–781, 1967
83. Maren TH: Chemistry of the renal reabsorption of bicarbonate. *Can J Physiol Pharm* 52:1041–1050, 1974
84. Cross CE, Packer BS, Linta JM, et al: H⁺ buffering and excretion in response to acute hypercapnia in the dogfish *Squalus acanthias*. *Amer J Physiol* 216:440–452, 1969
85. Scott D: Excretion of phosphorus and acid in the urine of sheep and calves fed either roughage or concentrate diets. *Quart J exp Physiol* 57:379–392, 1972
86. Minnich JE: Excretion of urate salts by reptiles. *Comp Biochem Physiol* 41A:535–549, 1972
87. Cameron JN, Wood CM: Renal function and acid-base regulation in two Amazonian erythrinid fishes: *Hoplias malabaricus*, a water breather, and *Hoplerethrinus unitaeniatus*, a facultative air breather. *Can J Zool* 56:917–930, 1978

88. Long WS: Urinary acidification in *Bufo marinus*. I. Studies *in vivo*. Submitted for publication
89. Coulson RA, Hernandez T: Biochemistry of the alligator. Louisiana State University Press. Baton Rouge, La, 1964
90. Wolbach RA: Renal regulation of acid-base balance in the chicken. *Amer J Physiol* 181:149-156, 1955
91. Sartorius OW, Roemmel JC, Pitts RF: The renal regulation of acid-base balance in man. IV. The nature of the renal compensations in ammonium chloride acidosis. *J Clin Invest* 28:423-439, 1949
92. Polak A, Haynie GD, Hays RM, et al: Effects of chronic hypercapnia on electrolyte and acid-base equilibrium. I. Adaptation. *J Clin Invest* 40:1223-1237, 1961
93. Motais R, Garcia-Romeu F: Transport mechanisms in the teleostean gill and amphibian skin. *Ann Rev Physiol* 34:141-176, 1972
94. Jacobs MH: Some aspects of cell permeability to weak electrolytes. *Cold Spring Harbor Symp. Quant Biol* 8:30-39, 1940
95. Goldstein, L: Ammonia production and excretion in the mammalian kidney. *International Review of Physiology*. Vol 11. Kidney and urinary tract physiology II. Edited by K Thirau. Baltimore, University Park Press, 1976, pp 283-316
96. Leonard E, Orloff J: Regulation of ammonia excretion in the rat. *Amer J Physiol* 182: 131-138, 1955
97. Orloff J, Berliner R: The mechanism of the excretion of ammonia in the dog. *J Clin Invest* 35:223-235, 1956
98. Scott D: Renal excretion of potassium and acid by sheep. *Quart J exp Physiol* 54:412-422, 1969
99. Jungreis AM: Partition of excretory nitrogen in amphibians. *Comp Biochem Physiol* 53A: 133-141, 1976
100. Walker AM: Ammonia formation in the amphibian kidney. *Amer J Physiol* 131:187-194, 1940
101. Hayes CP Jr, Mayson JS, Owen EE, et al: A micropuncture evaluation of renal ammonia excretion in the rat. *Amer J Physiol* 207:77-83, 1964
102. Ullrich KJ, Hilger HH, Klumper JD: Sekretion von Ammoniumionen in den Sammelrohren der Säugetiere. *Pflügers Arch ges Physiol* 267:244-250, 1958
103. Gottschalk CW, Lassiter W, Mylle M: Localization of urine acidification in the mammalian kidney. *Amer J Physiol* 198:581-585, 1960