

A new system to prevent SARS-CoV-2 and microorganism air transmission through the air circulation system of endoscopes



Authors

Stanislas Chaussade¹, Anna Pellat¹, Felix Corre¹, Rachel Hallit¹, Einas Abou Ali¹, Arthur Belle¹, Maximilien Barret¹, Paul Chaussade¹, Romain Coriat¹

Institution

1 Gastroenterology and Digestive Endoscopy Unit, Cochin University Hospital, Assistance Publique-Hôpitaux de Paris, Université de Paris, Paris, France

submitted 17.5.2022

accepted after revision 18.7.2022

Bibliography

Endosc Int Open 2022; 10: E1589–E1594

DOI 10.1055/a-1907-3939

ISSN 2364-3722

© 2022. The Author(s).

This is an open access article published by Thieme under the terms of the Creative Commons Attribution-NonDerivative-NonCommercial License, permitting copying and reproduction so long as the original work is given appropriate credit. Contents may not be used for commercial purposes, or adapted, remixed, transformed or built upon. (<https://creativecommons.org/licenses/by-nc-nd/4.0/>)

Georg Thieme Verlag KG, Rüdigerstraße 14, 70469 Stuttgart, Germany

Corresponding author

Professor Stanislas Chaussade, MD, PhD, Service de Gastroentérologie et d'Endoscopie Digestive, Hôpital Cochin, 27 rue du Faubourg St Jacques, 75014 Paris, France
Fax: +33(1)58411965
Stanislas.chaussade@gmail.com

ABSTRACT

Background and study aims Evidence for the modes of transmission of SARS-CoV-2 remains controversial. Recently, the potential for airborne spread of SARS-CoV-2 has been stressed. Air circulation in gastrointestinal light source boxes and endoscopes could be implicated in airborne transmission of microorganisms.

Methods The ENDOBOX SC is a 600×600 mm cube designed to contain any type of machine used during gastrointestinal endoscopy. It allows for a 100-mm space between a machine and the walls of the ENDOBOX SC. To use the ENDOBOX SC, it is connected to the medical air system and it provides positive flow from the box to the endoscopy room. The ENDOBOX SC uses medical air to inflate the digestive tract and to decrease the temperature induced by the microprocessors or by the lamp. ENDOBOX SC has been investigated in different environments.

Results An endoscopic procedure performed without ventilation was interrupted after 40 minutes to prevent computer damage. During the first 30 minutes, the temperature increased from 18 °C to 31 °C with a LED system. The procedure with fans identified variations in temperature inside the ENDOBOX SC from 21 to 26 °C (±5 °C) 1 hour after the start of the procedure. The temperature was stable for the next 3 hours.

Conclusions ENDOBOX SC prevents the increase in temperature induced by lamps and processors, allows access to all necessary connections into the endoscopic columns, and creates a sterile and positive pressure volume, which prevents potential contamination from microorganisms.

Introduction

Evidence for modes of transmission of SARS-CoV-2 remains controversial. In 2020, at the beginning of the pandemic, extreme safety precautions were taken to prevent direct and indirect droplet transmission through fomites. These recommendations were implemented to prevent the spread of the virus from patients to health care professionals (HCPs) and from

HCPs to patients, especially during digestive endoscopy [1]. Some studies suggested the potential for airborne transmission in specific environments, mainly poorly ventilated indoor or health care facilities [2]. The spread of SARS-CoV-2 has been compared to that of other viruses such as SARS-Cov1 and the measles, and also other microorganisms such as tuberculosis and fungi [3, 4]. However, separating SARS-CoV-2 transmission into the dichotomy of droplets vs airborne transmission has

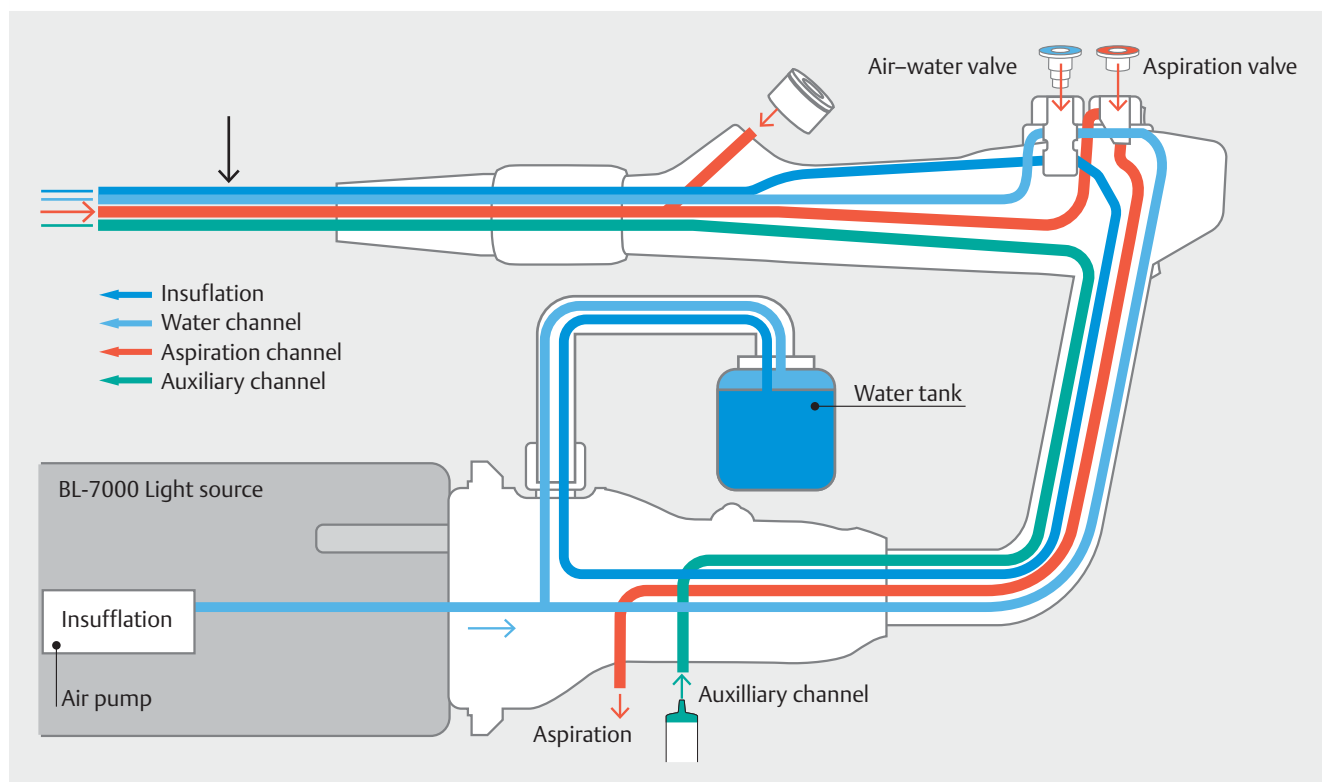

► **Fig. 1** Putative microorganism circulation in the light source and the environment of the endoscopic room.

been shown to be artificial. The switch from droplet to airborne precautions fed the controversy regarding respiratory protections to prevent transmission of SARS-CoV-2.

Recently, assessment of air contamination by SARS-CoV-2 in hospital settings has shown that air near and distant from contaminated patients may carry viral RNA [5]. It has also been suggested that aerosol transmission is increased with the new variants (alpha and delta), underscoring the need to prevent all methods of aerosolization in hospitals, and particularly in endoscopy units [6]. During aerosol-generating medical procedures, the production of both airborne particles and droplets may increase the risk of infection. Anesthesiology procedures, especially with orotracheal intubation, and upper digestive endoscopies, can generate aerosols favoring the transmission of the virus in the endoscopic room and especially in the close environment of patients and HCP [7, 8]. Therefore, good compliance with procedures and protocols designed for the safety of patients and HCPs is essential in endoscopy rooms. Recently it has been shown that rates of SARS-CoV-2 transmission during gastrointestinal endoscopy was low but transmission was possible [9, 10].

Considering the way gastrointestinal columns were built, air circulation in the gastrointestinal light source box and endoscope could be implicated in airborne transmission of microorganisms. Small viral particles or other microorganisms could contaminate the air used to inflate the gastrointestinal tract via the endoscope, which comes from the light box of the endoscopic column. Indeed, the air pump, which has no high-efficiency

particulate air (HEPA) filter, is not accessible for sterilization/decontamination. This pump is used to inflate air in the gastrointestinal tract through the air channel of the endoscope and through the water channel after inflation of air in the water tank [11]. The incoming air is aspirated in the light box and then expelled from the box by two or three fans with a very high flow (4 to 5 m³/min) [11, 12]. As proposed by Matteo et al, [13] this contamination route must be considered and the development of modified ventilation systems seems necessary to reduce as much as possible the putative risk of spreading the virus in an endoscopy room.

Based on those weaknesses, the ENDOBOX SC was developed to protect both patients and HCPs from airborne virus transmission through the endoscopic system.

Methods

New material: Endobox SC

Air circulation in the light box and the endoscope is illustrated in ► **Fig. 1**. Putative microorganism circulation in the light source and the environment from a hypothetical contaminated patient is illustrated in ► **Fig. 2**. The ENDOBOX SC is a 600 × 600 mm cube made of transparent Plexiglas (8-mm thickness). The ENDOBOX SC has been designed to hold all types of machines used during gastrointestinal endoscopy and leave a 100-mm space between a machine and the walls of the ENDOBOX SC to allow for air circulation (► **Fig. 3**). On the back of the ENDOBOX SC, a dedicated port was created to connect the

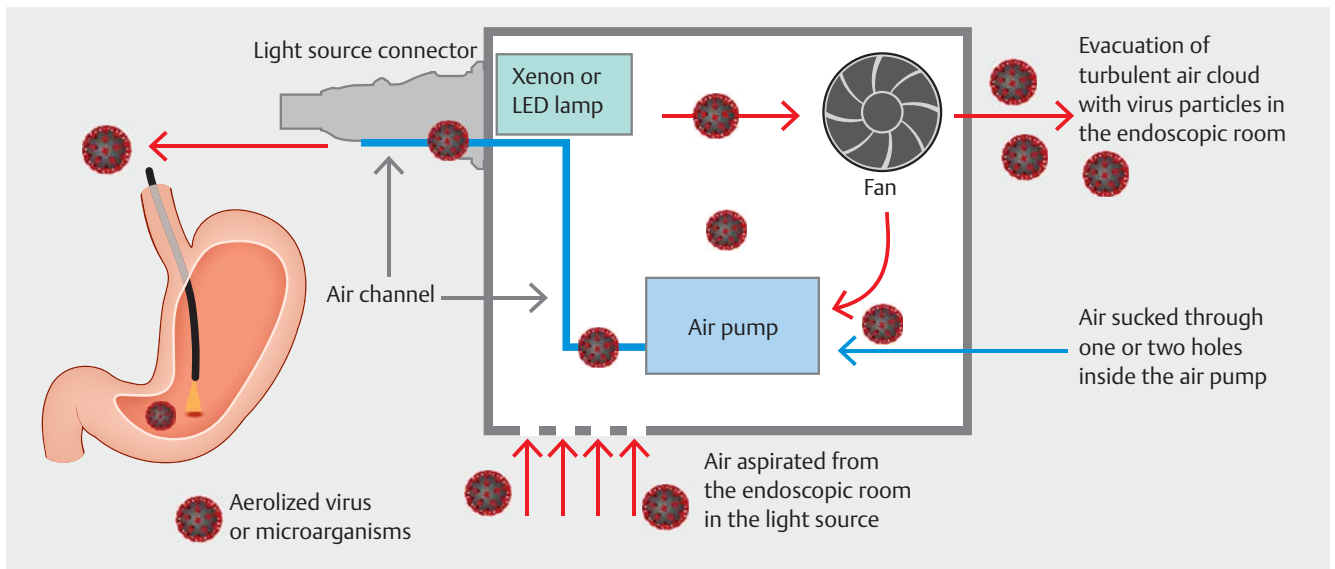

► **Fig. 2** Circulation of air into a digestive endoscope showing the origin of air.

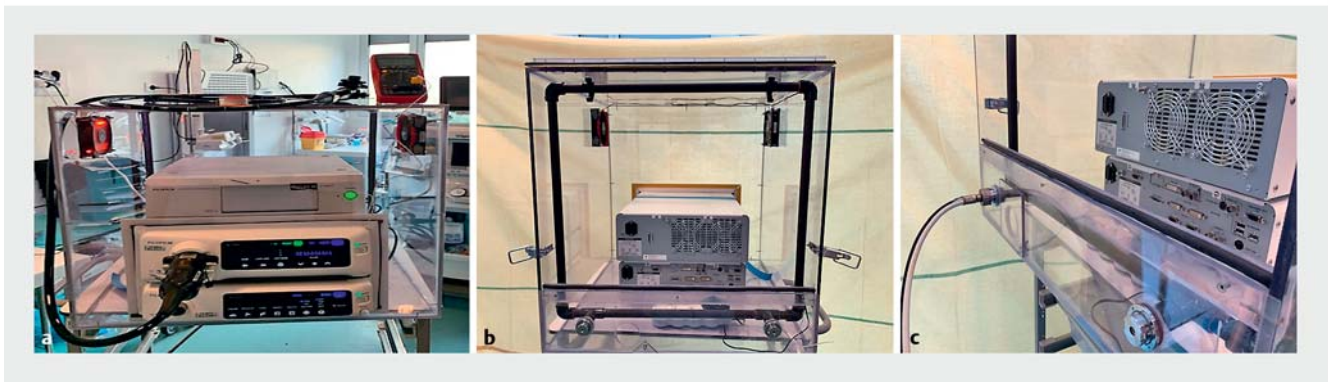

► **Fig. 3** **a** Anterior and **b** posterior views of the ENDOBOX SC. The posterior view of the ENDOBOX SC shows a multi holes PVC ramp to control the pressure inside **c** the box.

light, the processor box with electrical current, and the screen. Another port was made to connect the ENDOBOX SC to the medical air system. Medical air is present in all endoscopy units to help anesthesiologists during the intubation and ventilation period. It creates a constant and microorganism-free air circuit. The ENDOBOX SC uses the “medical air” to inflate the digestive tract and to decrease the temperature induced by microprocessors or by the lamp (ie 323 °C for a Xenon lamp). The airflow of medical air is controlled by a pressure gauge and is then blown in the box through a multi-hole PVC ramp (► **Fig. 4**). The ENDOBOX SC has a fan on each lateral side (120×120 mm; Corsair AF120; 12V; 1500 RTW/mn) to direct medical air outside the box into the endoscopic room. Such a mechanism allows a positive flow from inside to outside. The front of the ENDOBOX SC has adapters to enable it to be connected to endoscopes from any manufacturers (► **Fig. 3** and ► **Fig. 4**), and to enable a connection between the light box and the pipe of the endoscope and setting of the dashboard of the light and the processor box. A gasket ensures that the ENDOBOX SC is airtight.

Procedures

The ENDOBOX SC was developed to create a virus-free zone considering the potential for airborne transmission of a virus. Recently it has been shown that there is aerosolization of virus during esophagogastroduodenoscopy. The weakness of the box is the risk of a major increase in temperature inside the box caused by the light source or the microprocessors. The light source contains a forced-air cooling system to maintain a stable temperature in the middle of the box (25 °C). The air used by the forced-air cooling system is sucked from the closed environment of the patient through aeration ports, located close to the light source and evacuated out of the box by several fans [11, 12]. The volume of air that goes through the light source box may be very high (4 to 5 m³/minute ie 240 to 300 m³ for a 1-hour examination) [11]. As illustrated in ► **Fig. 3**, an Eluxeo system (FUJIFILM) was used to test the ENDOBOX SC. The Eluxeo System was placed in the ENDOBOX SC with the light box, the processor box, and the endoscopic ultrasound

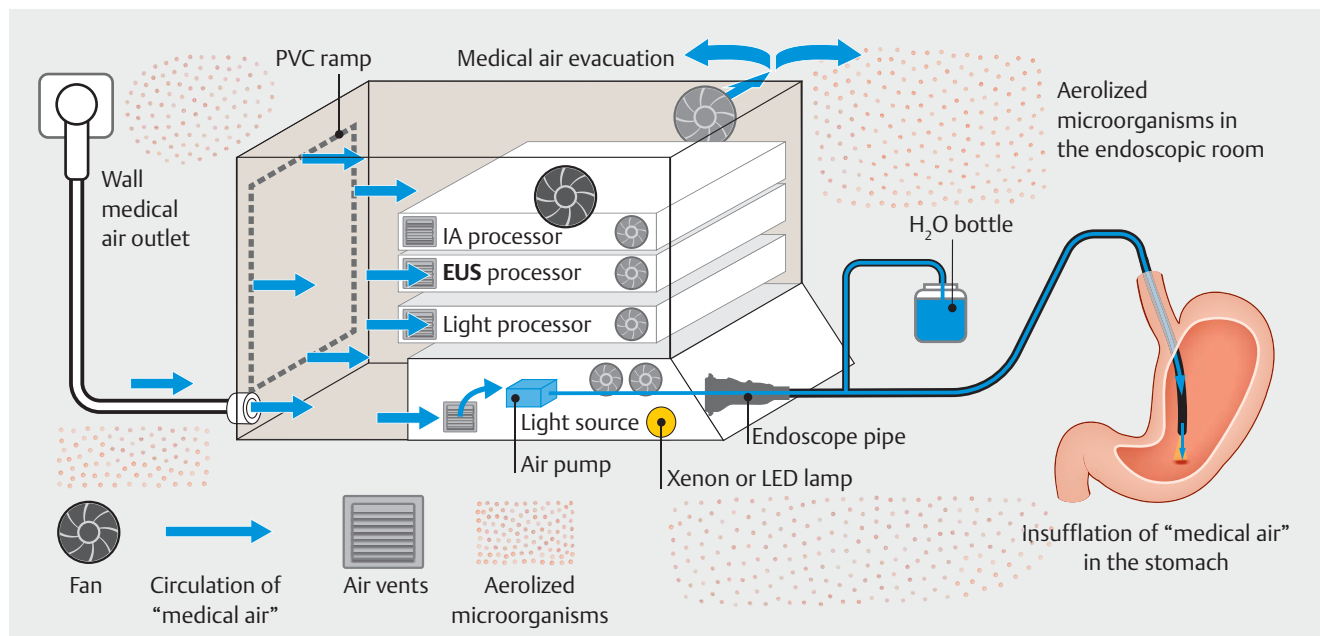

▶ **Fig. 4** Circulation of medical air from the wall outlet to the ENDOBOX SC, the light box and the endoscope, showing the absence of potential contamination using the medical air from the endoscopic room.

box. The position of the Eluxeo box conformed to manufacturer recommendations (100-mm distance between the system and each side of the ENDOBOX SC to allow airflow). The ENDOBOX SC was used for 3 hours with all different types of light, with either standard or ultrasound endoscopes. Variations in temperature inside the ENDOBOX SC were continuously measured.

A two-step procedure was performed. The ENDOBOX SC was not connected to the medical air during the first procedure: The endoscope pipe was connected to the light box and the light system of the endoscope was on. The ENDOBOX SC was first challenged without the use of fans in clinical conditions for 15, 30, 45, 60, 120, and 180 minutes. The second procedure corresponded to "optimal" utilization of the ENDOBOX SC. The device connected to the medical air, the fans were on, the endoscope pipe was connected to the light box, and the light system of the endoscope was on. The ENDOBOX SC was evaluated in clinical conditions for 15, 30, 45, 60, 120, and 180 minutes. During both procedures, temperature was constantly monitored to prevent computer damage. The procedure was to be stopped if the variation in temperature was more than $\pm 20^\circ\text{C}$ or if the temperature inside the box was higher than 35°C .

Results

The ENDOBOX SC was tested to evaluate the increase in temperature in clinical conditions in two steps. During the first procedure, the procedure was interrupted after 40 minutes due to a rapid increase in temperature. The temperature reached 35°C in 40 minutes, justifying an interruption of the test. During the first 30 minutes, the temperature increased from 18°C to 31°C with a LED system. The test was performed three times with similar results.

During the second procedure, the fans were on and the ENDOBOX SC was connected to the "medical air" system. During the overall procedure, there were small variations in temperature inside the ENDOBOX SC from 21°C to 26°C ($\pm 5^\circ\text{C}$) 1 hour after the beginning of the procedure, confirming that medical air could be used safely. The temperature was stable during the 3-hour procedure.

Discussion

ENDOBOX SC was developed to eliminate the potential risk of transmission of viruses and other microorganisms associated with the air circulation system used during gastrointestinal endoscopic procedures and also to allow ventilation of the system to limit an increase in temperature. The ENDOBOX SC allows access to all necessary connections to the endoscopy columns, creating a microorganism-free "zone" and positive pressure volume, which prevents potential contamination from microorganisms and avoids an increase in temperature levels induced by light and processors.

Recently it has been shown that rates SARS-CoV-2 transmission during gastrointestinal endoscopy are low but transmission is possible [10]. In that prospective study of 2440 patients, 30 (1.27%) patients presented with COVID-19 symptoms in the 2 weeks following gastrointestinal endoscopy, 16 (0.65%) of whom tested positive for SARS-CoV-2. Only three cases (0.12%) were attributed to transmission from endoscopy attendance, because no other more likely source of transmission was identified on direct questioning by the local care team [10]. Mechanisms of transmission are still unclear but could be related to air transmission of the virus. Indeed, viable SARS-CoV-2 has been found in hospital air [14], on a ventilator monitor

close to an endoscopic system, on the floor beneath patients' beds, and in one case in an endoscope [15]. Some medical or surgical procedures increase transmission risk for respiratory pathogens because they directly generate aerosols or during tracheal intubation. Aerosol transmission of certain diseases is biologically plausible when: (1) infectious aerosols are generated from an infector; (2) the pathogen contained in the aerosol in the aerosols remained viable in the air; and (3) the target tissues are accessible to the aerosols where the pathogens initiate infection [16]. All endoscopy rooms are indoor places. Many indoor places are poorly ventilated. Ventilation in those rooms helps to increase air circulation and meantime increase the risk of airborne transmission. To reduce the aerosol concentration and spread in an endoscopy room, some authors have proposed using box fan air cleaners [17]. Such procedures have been tested in a classroom where the overall risk is different from endoscopy unit. However, gastrointestinal and specifically upper endoscopies have unique qualities, in relation to other endoscopic or surgical procedures.

First, esophagogastroduodenoscopy is performed through the mouth or nose (nasogastrosocopy). Several recent proof-of-concept studies have reported increased levels of aerosol measured during esophagogastroduodenoscopy and concluded that the procedure increased the risk of aerosol-generating contamination [7,18]. It has been shown recently that patients who coughed during the procedure (60%) produced a very high number of particles. Considering that any emitted plumes of aerosol may contain viable viruses or microorganisms, it creates a potential risk of exposure for endoscopists or HCPs. In addition, tracheal intubation performed during endoscopic procedures could generate microorganism aerosols.

Second, gastrointestinal endoscopes are able to insufflate air inside the lumen of the gastrointestinal tract. This air is insufflated directly in the gut by a pump through the air channel or indirectly through the water channel of the endoscope because air is used to propel water from the water tank to the tip of the endoscope [11]. Therefore, air contaminated by viruses, fungi, tuberculosis or other bacteria could lead to contamination of the air circulation system and the air pump of the light source. The air circulation system could become an inaccessible niche for microorganisms, which could be able to contaminate other patients, because the air pump cannot be routinely cleaned. In such cases, contamination of the air circulation system of the light source or the air pump could contaminate a patient during an endoscopic procedure, despite negative virological and bacterial testing after careful disinfection of an endoscope with peracetic acid [19]. Meanwhile, aspiration of "contaminated" air in the system (light or processor box) may also result in contamination of all future patients [20].

Third, as described by Klompas et al [21], other factors seemed to play an important role in the occurrence of SARS-CoV-2 infection, such as the proximity between patients and HCPs, the proximity between patients and the endoscopic system, the duration of exposure to the microorganism, and ventilation of the room. During gastrointestinal endoscopies, there is close proximity between patients, who do not wear masks during the procedure, the HCP and the endoscopic system, al-

lowing for transmission of an aerosolized particle of virus from patients to HCP or to the endoscopy system, which cannot be cleaned between procedures.

Fourth, colonoscopy could also be an aerosolized procedure, as it has been described during colonic biopsy removal for bacteria and because SARS-CoV-2 or other microorganisms are present in fecal samples [22,23].

Conclusions

ENDOBOX SC enables access to all necessary connections to the endoscopy columns and creates a sterile and positive pressure volume, which prevents potential contamination from microorganisms to patients and to HCPs. Because there is a potential risk of contamination of patients by microorganisms in the air circulation system of endoscopes, it appears worthwhile to evaluate different strategies to mitigate the risk of air transmission. The use of the ENDOBOX SC system could be an option and deserves further study.

Competing interests

Dr. Chaussade holds a patent for ENDOBOX SC (Patent AHPH FR 3 111 273)

References

- [1] Gralnek IM, Hassan C, Beilenhoff U et al. ESGE and ESGENA Position Statement on gastrointestinal endoscopy and the COVID-19 pandemic. *Endoscopy* 2020; 52: 483–490
- [2] Dinoi A, Feltracco M, Chirizzi D et al. A review on measurements of SARS-CoV-2 genetic material in air in outdoor and indoor environments: Implication for airborne transmission. *Sci Total Environ* 2022; 809: 151137
- [3] Yu ITS, Li Y, Wong TW et al. Evidence of airborne transmission of the severe acute respiratory syndrome virus. *N Engl J Med* 2004; 350: 1731–1739
- [4] Morawska L, Milton DK. It is time to address airborne transmission of Coronavirus Disease 2019 (COVID-19). *Clin Infect Dis* 2020; 71: 2311–2313
- [5] Birgand G, Peiffer-Smadja N, Fournier S et al. Assessment of air contamination by SARS-CoV-2 in hospital settings. *JAMA Netw Open* 2020; 3: e2033232
- [6] Port JR, Yinda CK, Avanzato VA et al. Increased small particle aerosol transmission of B.1.1.7 compared with SARS-CoV-2 lineage A in vivo. *Nat Microbiol* 2022; 7: 213–223
- [7] Sagami R, Nishikiori H, Sato T et al. Aerosols produced by upper gastrointestinal endoscopy: a quantitative evaluation. *Am J Gastroenterol* 2021; 116: 202–205
- [8] Jackson T, Deibert D, Wyatt G et al. Classification of aerosol-generating procedures: a rapid systematic review. *BMJ Open Res* 2020; 7: e000730
- [9] Hayee B, Thoufeeq M, Rees CJ et al. Safely restarting GI endoscopy in the era of COVID-19. *Gut* 2020; 69: 2063–2070
- [10] Hayee B, The SCOTS II Project group, Bhandari P et al. COVID-19 transmission following outpatient endoscopy during pandemic acceleration phase involving SARS-CoV-2 VOC 202012/01 variant in UK. *Gut* 2021; 70: 2227–2229

- [11] Chaussade S, Ali EA, Hallit R et al. Air circulation in a gastrointestinal light source box and endoscope in the era of SARS-CoV-2 and airborne transmission of microorganisms. *Endosc Int Open* 2021; 09: E482–E486
- [12] Chaussade S, Hallit R, Abou AliE et al. SARS-CoV-2 in endoscopy: a potential way of microorganisms' air transmission. *Gut* 2022; 71: 656–657
- [13] Matteo MV, Boškoski I, Costamagna G. SARS-COV-2 in endoscopy: still a long way to go. *Gut* 2021; 70: 1629–1631
- [14] Lednicky JA, Lauzardo M, Fan ZH et al. Viable SARS-CoV-2 in the air of a hospital room with COVID-19 patients. *Int J Infect Dis* 2020; 100: 476–482
- [15] Somerville CC, Shoaib M, Kuschner CE et al. Prospective analysis of SARS-CoV-2 dissemination to environmental surfaces during endoscopic procedures. *Endosc Int Open* 2021; 09: E701–E705
- [16] Jones RM, Brosseau LM. Aerosol transmission of infectious disease. *J Occup Environment Med* 2015; 57: 501–508
- [17] He R, Liu W, Elson J et al. Airborne transmission of COVID-19 and mitigation using box fan air cleaners in a poorly ventilated classroom. *Physics Fluids* 2021; 33: 057107
- [18] Chan SM, Ma TW, Chong MK-C et al. A proof of concept study: esophagogastroduodenoscopy is an aerosol-generating procedure and continuous oral suction during the procedure reduces the amount of aerosol generated. *Gastroenterology* 2020; 159: 1949–1951.e4
- [19] Boškoski I, Di Gemma A, Matteo MV et al. Endoscopes used in positive and critically ill patients are SARS-CoV-2 negative at virological assessment. *Gut* 2021; 70: 1629–1631
- [20] Gregson FKA, Shrimpton AJ, Hamilton F et al. Identification of the source events for aerosol generation during oesophago-gastro-duodenoscopy. *Gut* 2022; 71: 871–878
- [21] Klompas M, Baker M, Rhee C. What is an aerosol-generating procedure? *JAMA Surgery* 2021; 156: 113–114
- [22] Vavricka S, Tutuian R, Imhof A et al. Air suctioning during colon biopsy forceps removal reduces bacterial air contamination in the endoscopy suite. *Endoscopy* 2010; 42: 736–741
- [23] Wu Y, Guo C, Tang L et al. Prolonged presence of SARS-CoV-2 viral RNA in faecal samples. *Lancet Gastroenterol Hepatol* 2020; 5: 434–435