

Structural and functional diversity of cadherin at the adherens junction

Hiroki Oda^{1,2} and Masatoshi Takeichi³

¹JT Biohistory Research Hall, Takatsuki, Osaka 569-1125, Japan

²Department of Biological Sciences, Graduate School of Science, Osaka University, Osaka, Japan

³RIKEN Center for Developmental Biology, Minatojima-Minamimachi, Chuo-ku, Kobe 650-0047, Japan

Adhesion between cells is essential to the evolution of multicellularity. Indeed, morphogenesis in animals requires firm but flexible intercellular adhesions that are mediated by subcellular structures like the adherens junction (AJ). A key component of AJs is classical cadherins, a group of transmembrane proteins that maintain dynamic cell–cell associations in many animal species. An evolutionary reconstruction of cadherin structure and function provides a comprehensive framework with which to appreciate the diversity of morphogenetic mechanisms in animals.

Introduction

Cell–cell adhesion is a fundamental structural feature of multicellular organisms. It is therefore important to understand how cell–cell adhesion mechanisms evolved and how they have contributed to the generation of diversity among animal species. Cell adhesion in animal cells is mediated by a set of specialized membrane structures termed intercellular junctions. Over the course of morphological evolution, metazoan animals have also diversified the architecture of their cell–cell junctions. Epithelia in the vertebrates typically have a junctional complex comprising a tight junction (TJ), adherens junction (AJ), and desmosome; these junctional types are located in this order starting from the apical end of the lateral cell–cell contacts (Fig. 1 A; Farquhar and Palade, 1963). In contrast, the arthropods bear the AJ and the septate junction (SJ), but no TJ or desmosome (Fig. 1 A). Despite such variations in overall junctional architecture, AJs are detected throughout the metazoan phyla, whereas other junctional types show restricted phylogenetic distributions (Fig. 1 B). Thus, AJs could be considered the universal adhesion machinery for the generation and maintenance of multicellular animal bodies.

Correspondence to Hiroki Oda: hoda@brh.co.jp; or Masatoshi Takeichi: takeichi@cdb.riken.jp

Abbreviations used in this paper: AJ, adherens junction; EC, extracellular cadherin domain; LmG, laminin globular domain; PCPS, primitive classical cadherin proteolytic site domain; SJ, septate junction; TJ, tight junction.

Studies of the vertebrates and *Drosophila* have identified the cell–cell adhesion molecules responsible for the formation of these different junctions. In both groups, “cadherins” have been identified as molecular components of the AJs (Fig. 1 A). Cadherins are transmembrane proteins that have characteristic repeated extracellular cadherin domains (ECs), each composed of ~110 amino acid residues, and a cytoplasmic region that binds p120-catenin and β -catenin/Armadillo at separate sites. p120-catenin stabilizes cadherins at the cell membranes, and β -catenin/Armadillo mediates the interactions of cadherins with the actin cytoskeleton via α -catenin; these processes play key roles in AJ function. In both vertebrates and *Drosophila*, cadherins are required not only for static cell–cell contacts but also for regulation of dynamic morphogenetic processes (Nishimura and Takeichi, 2009; Harris and Tepass, 2010). Despite the similarities in the biological functions of the vertebrate and *Drosophila* cadherins, however, their extracellular regions show significant differences in domain organization as well as in molecular size; and further differences are observed among the cadherins of different species.

In addition to the cadherins that function as AJ components, a number of related molecules have also been classified as members of the cadherin superfamily (Takeichi, 2007; Hulpiau and van Roy, 2009). These molecules possess the ECs like the AJ-associated cadherins, but their cytoplasmic amino acid sequences diverge considerably, implying that the various superfamily members interact with different molecules inside the cell. Representative members of the superfamily in the vertebrates and *Drosophila* are shown in Figs. 1 A and 2. Among them are proteins that still function as adhesion molecules: desmocollin and desmoglein are desmosomal components, whereas cadherin 23 and protocadherin 15 interact to form tip links that connect stereocilia in the inner ear (Kazmierczak et al., 2007). However, other members display different biological functions. For example, Fat cadherin and its binding partner Dachous regulate cell proliferation as well as planar cell polarity

© 2011 Oda and Takeichi This article is distributed under the terms of an Attribution–Noncommercial–Share Alike–No Mirror Sites license for the first six months after the publication date [see <http://www.rupress.org/terms>]. After six months it is available under a Creative Commons License [Attribution–Noncommercial–Share Alike 3.0 Unported license, as described at <http://creativecommons.org/licenses/by-nc-sa/3.0/>].

A Mouse (Vertebrata)

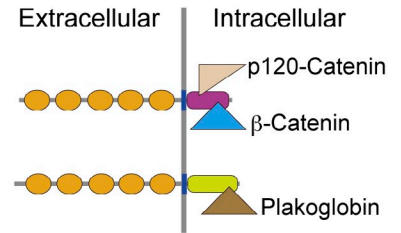
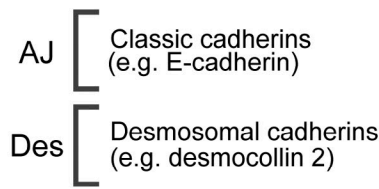
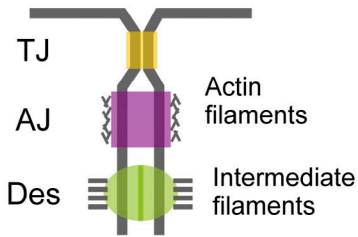

Drosophila (Arthropoda)

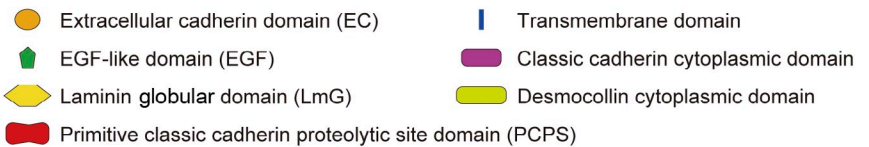
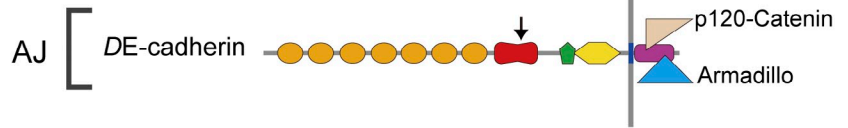
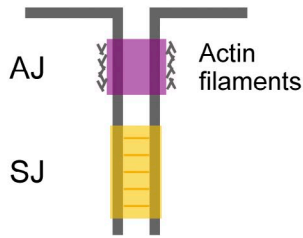

B

Components of junctional complexes observed in epithelia

		Components of junctional complexes observed in epithelia				References
		TJ	AJ	Des	SJ	
Chordata	Vertebrata	+	+	+	a	Farquhar and Palade (1963)
	Urochordata	+	+			Lane et al. (1986)
	Cephalochordata		+			Lane et al. (1987)
	Echinodermata		+		+	Spiegel and Howard (1983)
Bilateria	Arthropoda	b	+		+	Tepass and Hartenstein (1994)
	Nematoda (<i>C.elegans</i>)		+			Leung et al. (1999)
	Cnidaria		+		+	Wood (1959); Fritzenwanker et al. (2007)
Metazoa	Placozoa		+		+	Ruthmann et al. (1986)
	Porifera		+		+	Ledger (1975); Ereskovsky et al. (2009)
	Choanoflagellata					
	Dictyosteliida			c		Grimson et al. (2000)

Figure 1. **Diversity of intercellular junctions in the Metazoa.** (A) Components of the vertebrate and *Drosophila* junctional complexes found in typical mature epithelia. TJ, tight junction; AJ, adherens junction; Des, desmosome; SJ, septate junction. Cadherins and associated proteins that constitute the AJ and the Des are shown. The arrow at the PCPS of DE-cadherin indicates the proteolytic cleavage site. (B) Phylogenetic distributions of the junction types observed in epithelia. "a" denotes that SJ-like junctions are present in the nervous system of vertebrates (Bellen et al., 1998); "b" denotes that TJ-like junctions are present in the nervous system of chelicerate arthropods (Lane, 2001); and "c" denotes that AJ-like junctions are present in the slime mold *Dictyostelium*. References: Wood, 1959; Farquhar and Palade, 1963; Ledger, 1975; Spiegel and Howard, 1983; Lane et al., 1986, 1987; Ruthmann et al., 1986; Tepass and Hartenstein, 1994; Leung et al., 1999; Grimson et al., 2000; Fritzenwanker et al., 2007; Ereskovsky et al., 2009.

(Matakatsu and Blair, 2004; Reddy and Irvine, 2008; Ishiuchi et al., 2009), and Celsr/Flamingo functions also in planar cell polarity (Saburi and McNeill, 2005). Protocadherins form a large subfamily in the vertebrates, and its members are found in other chordates and bilaterians, whereas they are missing in *Drosophila*. The biological functions of protocadherins are not fully understood: many of them appear to destabilize cell-cell adhesions rather than stabilize them (Chen and Gumbiner, 2006; Yasuda et al., 2007; Nakao et al., 2008).

What is common throughout the superfamily members is that their extracellular domains are used for homophilic or

heterophilic interactions with other cadherin molecules. These interactions result in various cellular events such as adhesion and signaling, depending on the properties of cytoplasmic partners. Within each subfamily, the entire domain organization of the members tends to be conserved, even between phylogenetically distant bilaterian animals (e.g., this occurs in the Fat and Celsr/Flamingo subfamilies). In this respect, the cadherins responsible for AJ formation are rather unique, as they show a considerable diversification in their extracellular region.

In this review, we describe the structural diversity of "classic" cadherins essential for AJ formation in metazoans,

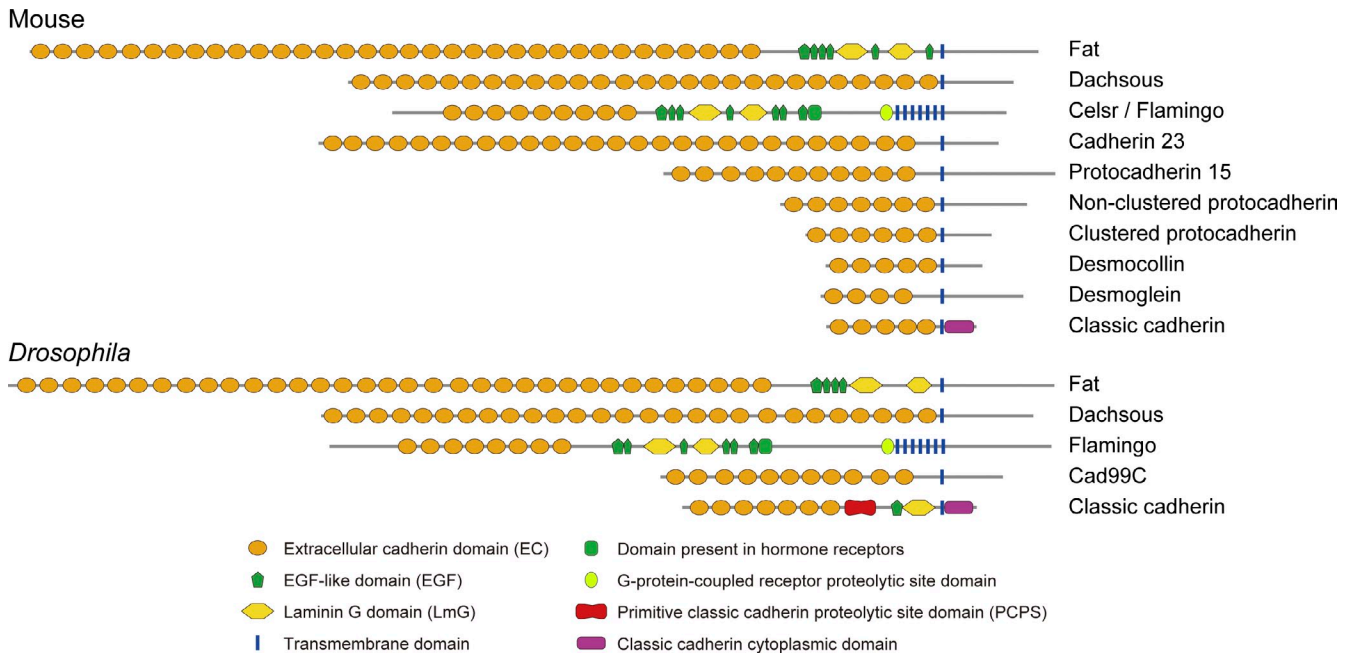

Figure 2. **The domain structures of representative members of the major cadherin subfamilies in the mouse and *Drosophila*.** Shown is a comparison of the domain structures based on predictions of domains by SMART/Pfam analysis, except for the PCPS in *DE*-cadherin. Some cadherin subfamilies are missing in *Drosophila*.

and we discuss the functional significance of this diversification. The classical cadherins (in contrast with other members of the cadherin superfamily) are defined as molecules with a conserved cytoplasmic region capable of binding p120-catenin and β -catenin/Armadillo, irrespective of the organization of their extracellular region.

Classical cadherins in vertebrates

Classical cadherins were originally identified as Ca^{2+} -dependent, homophilic adhesion molecules in vertebrates. The extracellular region of these cadherins consists of five ECs. The mammalian genome encodes ~ 20 subtypes of classical cadherin, all of which show the 5-EC organization. Each subtype has a binding preference for the same subtype, although many subtypes can cross-interact with other restricted subtypes. The 5-EC organization is also shared by desmocollin, which is not categorized as a classical cadherin because it has a distinct cytoplasmic domain that can bind plakoglobin but not β -catenin (Fig. 1 A). Despite this difference, desmocollin seems to be a close relative to the classical cadherins because of the highly conserved exon–intron organization between their genes (Greenwood et al., 1997). The other desmosomal cadherin, desmoglein, is less similar to the classical cadherins. Based on phylogenetic relationships, the vertebrate classical cadherins have been classified into type I (e.g., E- and N-cadherin) and type II (e.g., cadherin-6 and -8; Takeichi, 1995; Hulpiau and van Roy, 2009). Type-I cadherins play a major role in AJ-mediated cell–cell adhesion. For example, E-cadherin is expressed in most epithelial tissues, and N-cadherin is expressed by a variety of cell types, including neuroepithelial cells, neurons, and mesenchymal cells. Loss of these type-I cadherins results in the disorganization of the AJs, including synaptic

AJs (Takeichi and Abe, 2005). Type-II cadherins are also expressed by various cell types, such as mesenchymal and neuronal cells, but their role in AJ formation is not yet clearly defined. Their dysfunctions cause various physiological defects in cellular behavior and functioning, particularly in the nervous system (Suzuki and Takeichi, 2008). There is no strict tissue or organ specificity in the distribution of each classical cadherin subtype, except that VE-cadherin seems to be expressed exclusively in vascular endothelial cells.

In addition to type-I and type-II cadherins, there are exceptional classical cadherins, classified as type III, in non-mammalian vertebrates (Fig. 3 A; Tanabe et al., 2004). A representative is chicken cHz-cadherin, which encodes ~ 15 ECs. The transcripts for this cadherin are not clearly detectable in most embryonic tissues, except in the horizontal cells of the neural retina. cHz-cadherin is able to induce cell aggregation when introduced into cultured cells; however, its roles *in vivo* have not yet been determined.

Classical cadherins in *Drosophila* and other arthropods

The first classical cadherin identified in the invertebrates was *Drosophila melanogaster* *DE*-cadherin, which is the product of the *shotgun* locus (Tepass et al., 1996; Uemura et al., 1996). *DE*-cadherin differs from the vertebrate classical cadherins in its extracellular domain organization. It has seven ECs, in contrast with the five ECs in the vertebrate classical cadherins. Moreover, between the EC cluster and the transmembrane region, a primitive classical cadherin proteolytic site domain (PCPS, previously termed the nonchordate cadherin domain), an EGF-like domain (EGF), and a laminin globular domain (LmG) are present (Oda and Tsukita, 1999). Cadherins with

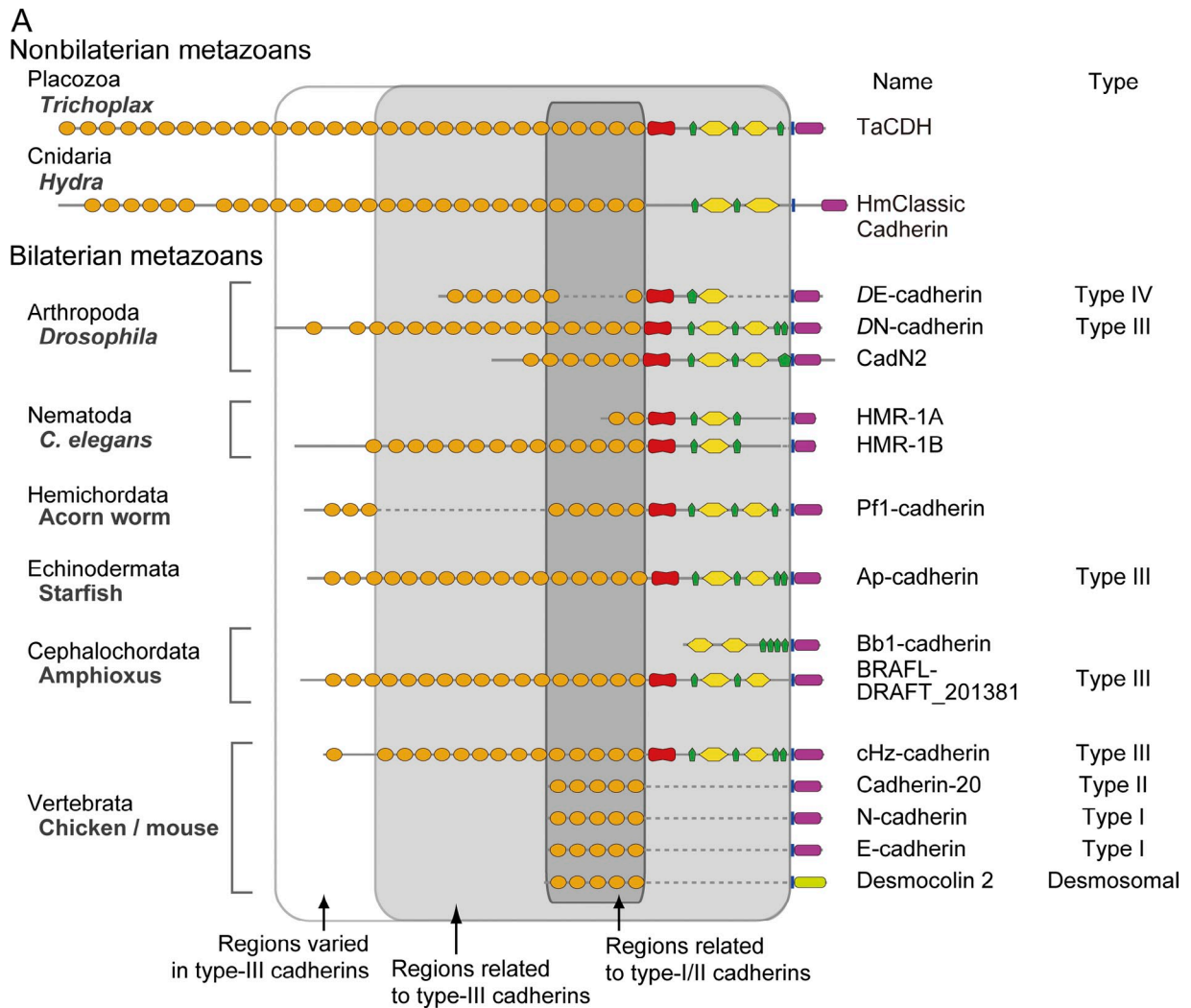

B

Type	Number of ECs	Number of PCPS	Number of EGFs	Number of LmGs
Type I/II	5	0	0	0
Type III	14~17	1	multiple	2
Type IV	7	1	1	1

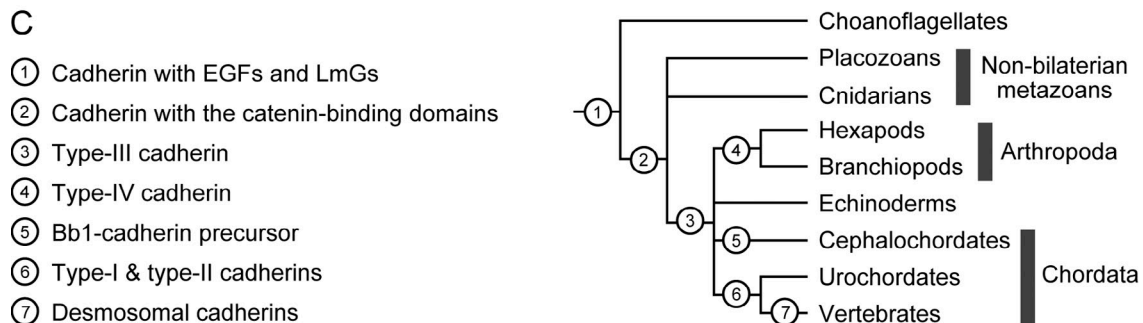

Figure 3. **Diversity and evolution of the extracellular domain structures of classical cadherins in the Metazoa.** (A) Comparison of the domain structures of selected classical cadherins and a desmosomal cadherin in bilaterian and nonbilaterian metazoan phyla. Gaps (dotted lines) are introduced to highlight homologous extracellular regions between distinct cadherins. (B) Comparison of the domain compositions among the classical cadherin types. (C) A possible phylogenetic diagram showing key genomic changes that contributed to the structural diversification of cadherins at the AJ and the desmosome.

essentially the same domain structure as *DE*-cadherin have been found in multiple species of insects and in a branchiopod crustacean, and are classified as type-IV cadherins (Oda et al., 2005; Hulpiau and van Roy, 2009). *DE*-cadherin is indispensable for epithelial AJ formation (Le Borgne et al., 2002; Wang et al., 2004).

The *Drosophila melanogaster* genome has two other genes encoding classical cadherins, namely *DN-cadherin/CadN* and *CadN2*, which are located close to each other (Fig. 3 A; Iwai et al., 1997; Prakash et al., 2005). *DN*-cadherin has 16 ECs and 2 LmGs, and therefore is much bigger than *DE*-cadherin. Multiple *DN*-cadherin isoforms are generated by alternative splicing, although these isoforms appear to be functionally redundant (Prakash et al., 2005; Ting et al., 2005; Hsu et al., 2009). Similar to the vertebrate N-cadherin, *DN*-cadherin is expressed in mesodermal and neural tissues. Despite their dissimilar structures, *DN*-cadherin and vertebrate N-cadherin play analogous roles in neural development and synaptic connections (Takeichi, 2007). This is similar to the relationship between *DE*-cadherin and vertebrate E-cadherin. Thus, although the overall structures of classical cadherins have diverged, the use of different cadherin subtypes for the assembly of different cell groups appears to have been conserved among species. *CadN2*, on the other hand, has only six ECs, and it exhibits no detectable adhesion activity (Yonekura et al., 2007). *CadN2*-null mutants are viable (Prakash et al., 2005), although *CadN2* has subtle functions that are partially redundant with those of *DN*-cadherin.

Despite their distant relationship, *DN*-cadherin and chicken cHz-cadherin resemble each other in their domain structures (Fig. 3 A). Because of this resemblance, *DN*-cadherin can be classified as a type-III cadherin. Compared with type-IV cadherins, type-III cadherins have been found in a broader range of arthropods (Oda et al., 2005). Type-III and -IV cadherins share a common framework consisting of three elements: the ECs, PCPS, and EGF/LmGs. However, they differ in the numbers of these domains (Fig. 3, A and B). In some noninsect arthropods, including a chelicerate spider, type-III but not type-IV cadherins localize at AJs in embryonic ectodermal epithelia, indicating that the epithelial AJs can use type-I, -II, -III, or -IV cadherins, depending on the species and tissue type.

Classical cadherins in other bilaterian metazoans

The genome of the nematode *Caenorhabditis elegans* has only a single classical cadherin gene, *hmr-1* (Costa et al., 1998). This gene appears not to be essential for maintaining general cell-cell adhesions in embryos, as the animals lacking *hmr-1* are able to develop through gastrulation. However, the leading cells at the site of ventral epithelial closure require *hmr-1*; for its absence, the closure fails (Raich et al., 1999). The *hmr-1* gene has a complicated structure encoding two isoforms, HMR-1A and HMR-1B, which have 2 and 14 ECs, respectively (Fig. 3 A; Broadbent and Pettitt, 2002). The transcript for HMR-1B is generated by an alternative, neuron-specific promoter, followed by alternative splicing. HMR-1B resembles *DN*-cadherin in its structure and function: Without HMR-1B, motor neuron axons

cannot normally grow out and fasciculate, as found in the case of *DN*-cadherin mutants. HMR-1A is likely the gene product involved in ventral epithelial closure. It shares its entire region with HMR-1B, except its N-terminal part encoded by a small, unique exon. At the ultrastructural level, the *C. elegans* junctional complex consists of only a single component (Fig. 1 B). At the molecular level, however, the presence of junctional subdivisions that are comparable to the *Drosophila* junctional complex has been predicted (Knust and Bossinger, 2002). In sum, *C. elegans* has a smaller epithelial cadherin and a larger neuronal cadherin, as found in *Drosophila*, and these two proteins are derived from a single gene.

The genome of the echinoderm sea urchin *Strongylocentrotus purpuratus* has only a single classical cadherin gene (Whittaker et al., 2006). Its likely orthologues, LvG-cadherin and Ap-cadherin, were identified in another sea urchin species and a starfish species, respectively (Miller and McClay, 1997; Oda et al., 2005). The domain structure of either of these echinoderm cadherins closely resembles that of *DN*-cadherin. However, unlike *DN*-cadherin, both echinoderm cadherins clearly localize at the AJ in epithelia. A proposed sister group of the echinoderms is the hemichordates. In the hemichordate *Ptychodera flava*, a classical cadherin whose extracellular domain structure is similar to but distinct from those of the echinoderm cadherins was identified as an epithelial AJ component (Oda et al., 2005). Thus, as in the case of arthropods, classical cadherins with various domain structures are used for epithelial junction formation in the echinoderm/hemichordate lineage.

The phylum Chordata consists of three subphyla: Vertebrata, Urochordata, and Cephalochordata. The genome of the urochordate ascidian *Ciona intestinalis* has only two classical cadherin genes (Sasakura et al., 2003), one related to the gene for type-I cadherins and the other to that for type-II cadherins. The presence of type-I and -II cadherins is thus a shared feature of the vertebrates and urochordates. In the cephalochordate amphioxus *Branchiostoma belcheri*, there is a pair of very unique cadherins, Bb1- and Bb2-cadherins (Fig. 3 A; Oda et al., 2002, 2004). These molecules have highly conserved classical cadherin cytoplasmic domains, which are able to form a complex with *Drosophila* α -catenin. However, they lack ECs in their extracellular regions. These Bb1- and Bb2-cadherins share the LmG/EGFs with type-III cadherins. More importantly, despite the lack of ECs, Bb1- and Bb2-cadherins are able to function as homophilic adhesion molecules. Consistent with the absence of Ca^{2+} -binding ECs, their activities are Ca^{2+} independent. Moreover, these molecules localize at the AJs in the embryonic epithelia, where β -catenin colocalizes, suggesting the possibility that they might have substituted for classical cadherins in this particular species. On the other hand, the genome database of the cephalochordate *Branchiostoma floridae* shows that, in addition to Bb1- and Bb2-cadherin orthologues, this species has a putative type-III cadherin (BRAFLDRAFT_201381; Putnam et al., 2008; Hulpiau and van Roy, 2011). This cadherin shows relatively high sequence similarity to cHz-cadherin.

In summary, classical cadherins in bilaterian metazoans show a large diversity in their extracellular domain organization (Fig. 3, A and B). Type-I and -II cadherins are expressed only by

species in the Vertebrata and Urochordata subphyla. All other species of the bilaterian metazoans express type-III, -IV, or another class of cadherins. When one species expresses multiple types or subtypes of these molecules, each molecule is specialized for the adhesion of particular cell groups. It should be noted that epithelial and neural cadherins are not functionally interchangeable in mouse development (Kan et al., 2007) or in *Drosophila* photoreceptor axon extension (Prakash et al., 2005). It has also been shown that *DE*- and *DN*-cadherins have opposing effects on the ommatidial rotation (Mirkovic and Mlodzik, 2006), and that these two cadherins differentially regulate retinal cell patterning (Hayashi and Carthew, 2004). These lines of evidence suggest a functional significance of the cadherin subtype diversification.

Potential mechanisms for cadherin diversification in the bilaterian metazoans

How have the classical cadherins diversified in the bilaterian metazoan? It should be noted that type-III domain structures are recognized in many different bilaterian lineages. BLAST-based comparisons of individual domains to identify homologous regions between type-III and other cadherins suggest that type-III cadherins might represent the ancestral form of bilaterian classical cadherins (Fig. 3, A and C; Oda et al., 2005; Hulpiau and van Roy, 2011). In addition, lineage-specific domain losses from type-III cadherins account well for the observed diversity. For example, the five ECs of mouse cadherin-20 and other type-II cadherins closely resemble the last five ECs of type-III cadherins, such as the *Branchiostoma* BRAFLDRAFT_201381 cadherin and *cHz*-cadherin, and are less similar to any five consecutive ECs of other cadherin superfamily members (Fig. S1; Hulpiau and van Roy, 2011). It is therefore likely that the 5-EC organization of type-I and type-II cadherins was established through a loss of N-terminal ECs, PCPS, and EGF/LmGs from an ancestral type-III cadherin. Likewise, the ECs of type-IV cadherins are similar to certain portions of type-III cadherins, supporting the idea that they also originated from a type-III cadherin. Importantly, any five consecutive ECs of type-IV cadherins are not homologous to the five ECs of type-I/II cadherins.

The ancestry of classical cadherins

Intercellular junctions in nonbilaterian metazoan species ultrastructurally resemble the bilaterian AJs (Fritzenwanker et al., 2007; Magie and Martindale, 2008). The recently available genomes of two cnidarian species, *Nematostella vectensis* and *Hydra magnipapillata*, and a placozoan species, *Trichoplax adhaerens*, revealed that they have conserved classical cadherin cytoplasmic domains (Abedin and King, 2008; Chapman et al., 2010; Hulpiau and van Roy, 2011). These putative classical cadherins resemble the bilaterian type-III cadherins except that they have much larger numbers of ECs (Fig. 3 A). The 14 C-terminal ECs of the *Trichoplax* cadherin, TaCDH, are suggested to be homologous to the 14 C-terminal ECs of bilaterian type-III cadherins (Fig. 3 A; Hulpiau and van Roy, 2011). Loss of the N-terminal ECs might have occurred during the nonbilaterian-to-bilaterian transition. Whether or not the cnidarian and placozoan classical cadherins localize at AJs remains to be determined.

The length and domain composition of the cnidarian and placozoan classical cadherins are similar to those of bilaterian Fat cadherins, which typically have 34 ECs, one or two LmGs, and several EGFs (Fig. 2). Some cnidarians have a Fat cadherin (Abedin and King, 2008). Fat and its heterophilic binding partner Dachshous are not the components of AJs, but are detected at the plasma membranes above the AJs (Ma et al., 2003; Ishiuchi et al., 2009). Nevertheless, the cytoplasmic domain of Dachshous contains the amino acid sequences, which are weakly but significantly similar to those of the cytoplasmic domains of classical cadherins (Clark et al., 1995). Thus, as far as primary structure is concerned, the cnidarian and placozoan classical cadherins possess combined features of the Fat and Dachshous cadherins. The evolutionary processes that gave rise to these three cadherin types, however, remain unclear.

Among the four major poriferan sponge groups, the Homoscleromorpha is thus far the only group in which intercellular junctions resembling the bilaterian AJ have been observed (Ereskovsky et al., 2009). *Amphimedon queenslandica*, belonging to another group, the Demospongiae, was the first sponge species to have its genome sequenced (Srivastava et al., 2010). In this species, a classical cadherin-like gene was identified (Sakarya et al., 2007; Abedin and King, 2008; Fahey and Degnan, 2010). This cadherin has EGF and LmG domains together with 14 ECs, but its cytoplasmic domain shows only weak sequence similarities to the cytoplasmic domains of bilaterian classical cadherins, even though a suite of catenin genes is present in the sponge genome. Whether the *Amphimedon* cadherin can bind catenins, and functions as an adhesion molecule, needs to be further investigated.

Choanoflagellates are considered to be the closest unicellular relatives of metazoans. The choanoflagellate *Monosiga brevicollis* genome has up to 23 cadherin genes; however, none of them contains a sequence related to the cytoplasmic domain of classical cadherins (Abedin and King, 2008). Because the domain compositions and organizations of these choanoflagellate cadherins are very unique, it is difficult to relate them to known metazoan cadherin families. Among them, MBCDH21 is the only cadherin that has a combination of ECs, LmG, EGF, and transmembrane domains. The predicted number of ECs in the extracellular region of this cadherin is 45, and a protein tyrosine phosphatase domain is present in the cytoplasmic region. This domain combination has not been found in the metazoans.

Although the *Monosiga* genome lacks β -catenin orthologues (Abedin and King, 2008), another nonmetazoan species, *Dictyostelium discoideum*, has a close homologue of β -catenin, Aardvark, which has been characterized as a component of actin-associated intercellular junctions (Grimson et al., 2000). Aardvark has a conserved sequence motif for binding to α -catenin. Recently, an α -catenin orthologue that is capable of binding to Aardvark as well as to mouse β -catenin in vitro was also identified in *Dictyostelium discoideum* (Dickinson et al., 2011). Functional studies suggested that Aardvark and this α -catenin orthologue regulate epithelial polarity and multicellular morphogenesis, although these molecules appear not to be essential for the formation of intercellular junctions (Dickinson et al., 2011). In addition, DdCAD-1, a protein of 213 amino acid residues, has weak sequence similarities to ECs, and functions

as a Ca^{2+} -dependent adhesion molecule during *Dictyostelium* multicellular development (Wong et al., 1996, 2002; Lin et al., 2006). This protein is, however, expressed extracellularly, lacking transmembrane and cytoplasmic domains (Sesaki et al., 1997). Therefore, Aardvark is unlikely to bind to DdCAD-1. The *Dictyostelium* genome, as well as the plant and fungus genomes, encodes no proteins containing typical EC repeats or those corresponding to the classical cadherin cytoplasmic domains (Abedin and King, 2008; Dickinson et al., 2011). Thus, the evolutionary history of classical cadherins has not been traced back to nonmetazoan organisms.

Structure-function relationships in the diversified cadherins

The type-III and -IV cadherins, in general, have larger numbers of EC domains than do the type-I/II cadherins. How do these ECs participate in the homophilic or heterophilic interactions between cadherin molecules? Many lines of research have aimed to elucidate the structural basis of the cadherin interactions, but using only vertebrate classical cadherins. Electron microscopic observations show that an isolated extracellular domain of type-I cadherins assumes a slightly curved, rod-like shape with a length of ~ 22 nm (Pokutta et al., 1994). Based on the results of x-ray crystallographic studies, it has been proposed that EC1 and residues near the EC1–EC2 calcium-binding sites play a central role in homophilic binding (Katsamba et al., 2009; Harrison et al., 2010). The role of EC3 to EC5 seems to be only to sustain the rod-like morphology of the molecules, although this part of the cadherin structure has not yet been thoroughly investigated. Such molecular analysis has not yet been conducted for type-III/IV cadherins, and it is totally unknown how the larger cadherins manage their repeated ECs in their interactions. For example, it remains to be determined whether these cadherins also use the N-terminal ECs or other ECs for their homophilic interactions.

According to the above model of type-I cadherin binding, the rod-like cadherin extracellular domains undergoing homophilic interactions need to tilt in order to accommodate themselves to the narrow intercellular space of 15–25 nm of the AJs (McNutt and Weinstein, 1973). Importantly, the overall structures of AJs, including the intercellular distances, are apparently conserved among the bilaterian metazoans. Nevertheless, the lengths of the extracellular regions of bilaterian classical cadherins vary considerably. How are the cadherins with longer sizes accommodated in this conserved “narrow” intercellular space? Do they further tilt or become globular? And, which mechanisms determine the conserved intercellular distances of the AJs? These questions remain to be answered. In the case of cadherin 23, which is another large cadherin belonging to the cadherin superfamily (Fig. 2), it exhibits a simple strand-like shape (Kazmierczak et al., 2007); but this cadherin can occupy wide inter-plasma membrane spaces between stereocilia.

Functions of the domains unique to the nonchordate classical cadherins

An important feature of the nonchordate classical cadherins is the presence of the PCPS/EGF/LmG domains in their extracellular juxtamembrane region. In the case of Ap-cadherin and

DE-cadherin, these domains cover ~ 38 and 30% of the entire extracellular region, respectively. What are the functions of these domains, which are missing in the vertebrate classical cadherins?

The PCPS domain was found to contain a proteolytic cleavage site. The mature *DE*-cadherin is composed of two polypeptides that have resulted from proteolytic cleavage at a specific site in the PCPS (Oda and Tsukita, 1999). After cleavage, these two polypeptides are noncovalently bound to each other, probably via the PCPS. The PCPS domain shows weak but significant sequence similarities to the ECs, suggesting that it might have diverged from an EC. The PCPS cleavage can be blocked by the introduction of amino acid substitutions at the cleavage site (Oda and Tsukita, 1999). However, such cleavage-lacking *DE*-cadherin mutants are able to fully rescue the morphological defects and lethality caused by the *shotgun*-null mutation, indicating that PCPS cleavage is not essential for the developmental role of *DE*-cadherin (Haruta et al., 2010). Analyses of *DE*-cadherin deletion constructs showed that the PCPS cleavage requires part of the adjacent EC7, implying that the EC7 and PCPS domains may form a functional unit. *DE* Δ P, a *DE*-cadherin derivative in which the PCPS/EGF/LmG and EC7 domains have been deleted, shows a strong cell–cell binding ability (Haruta et al., 2010). Ultrastructurally, the AJs in which *DE*-cadherin is replaced by *DE* Δ P show no recognizable abnormalities (Fig. 4). The intercellular distance between the junctional membranes is not significantly affected by the absence of the membrane-proximal half of the extracellular region, suggesting that the length of this region is not the major factor determining the space between plasma membranes. Furthermore, *DE* Δ P is also able to rescue, to a large extent, the defects caused by the *shotgun*-null mutation, suggesting that the PCPS/EGF/LmG region is dispensable not only for the homophilic binding of *DE*-cadherin but also for AJ assembly and the formation and maintenance of epithelia (Fig. 4).

Notably, however, the replacement of *DE*-cadherin with *DE* Δ P impairs the apical constriction of the cell layers, which drives ventral furrow formation early in *Drosophila* gastrulation (Fig. 4; Haruta et al., 2010). This indicates the importance of the PCPS/EGF/LmG domains for dynamic aspects of AJ function. Apical constrictions of ventral furrow cells are indeed a dynamic process accompanied by pulsed contractions of actomyosin networks that are tethered to the AJs (Dawes-Hoang et al., 2005; Martin et al., 2009). It is important to clarify how these domains are involved in such active cell–cell junctions. It should be noted that, although the vertebrate type-I/II cadherins have no mechanism by which to split themselves into two portions, the extracellular region of E- and N-cadherin can be cleaved by a metalloproteinase at a juxtamembrane site (Maretzky et al., 2005; Reiss et al., 2005). This nature of vertebrate cadherins may facilitate their turnover, which would be required when cells are undergoing remodeling of cell junctions. Given that the linkage between the two polypeptides of *DE*-cadherin is cleavable, the presence of the PCPS responsible for this linkage might be important for *DE*-cadherin turnover. In any case, solving the mystery of the role of the EC7-to-LmG region unique to the nonchordate classical cadherins will provide an insight into how cell–cell adhesion is controlled differently in the chordates and nonchordates.

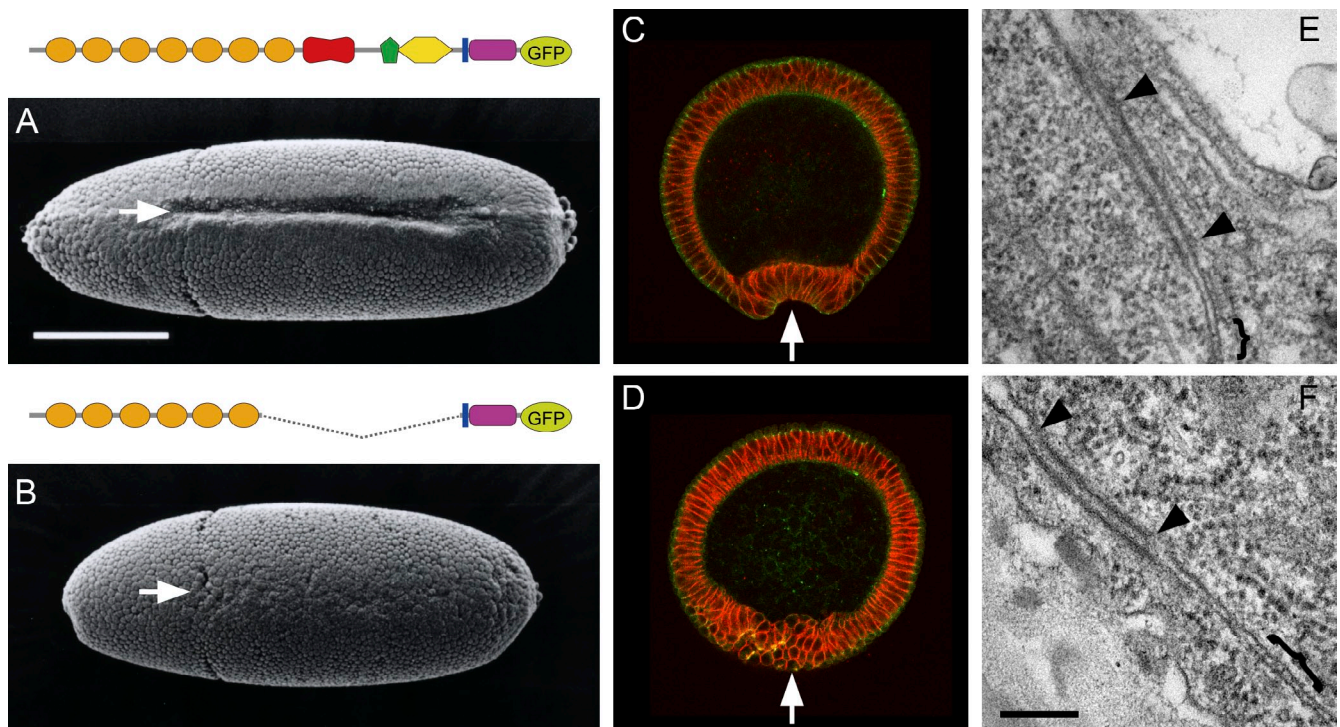

Figure 4. **Replacement of DE-cadherin with a shortened DE-cadherin, DE Δ P.** Shown are *Drosophila* embryos in which DE-cadherin was replaced with DE-cadherin-GFP (A, C, and E) or DE Δ P (B, D, and F), which was also tagged with GFP. (A and B) Scanning electron microscopy images showing the ventral view of early gastrulation-stage embryos. (C and D) Cross sections of early gastrulation-stage embryos. Green, GFP fluorescence; red, neurotactin staining. The ventral furrow is seen in A and C but not in B and D (arrows). The ectodermal epithelia developed normally in both embryo types. (E and F) Transmission electron microscopy images showing an apical region of cell contact in the lateral epidermis of late-stage embryos. AJ (arrowheads) and SJ (brackets) are seen in both E and F, where there are no recognizable distinctions. Bars: (A) 200 μ m; (F) 200 nm. Adapted from Haruta et al., 2010 with permission from John Wiley and Sons.

Perspectives

Despite the extensive diversification in their extracellular domain organization, the classical cadherins' cytoplasmic regions, as well as the apparent architecture of AJs where the classical cadherins are localized, are conserved among the species. This implies that the cytoplasmic region that interacts with catenins and other cytoplasmic molecules is most critical for the structure and functions of the AJs, and that the extracellular region is changeable. However, why the size and domain organization of the extracellular region can be so variable remains completely mysterious. To solve this mystery, it is necessary to know how large cadherins, such as type-III and -IV cadherins, undergo their homophilic or heterophilic interactions with other cadherins. It is particularly important to determine which ECs are critical for these interactions, and to determine the roles of other ECs. The functions of the conserved PCPS/EGF/LmG region also should be further investigated. A goal of these studies is to understand how the cadherins with different domain organizations undergo similar adhesive functions at the conserved intercellular structures.

At the same time, we should also ask whether the extracellular diversification of classical cadherins might have brought about their functional changes, and whether such changes would have any relevance to the morphological diversification of animals. It would be intriguing to test if a given cadherin in a particular species can be replaced with another cadherin derived from a separate species such that the morphogenesis of the former

is sustained. Besides, it is notable that the importance of classical cadherins in morphogenesis seems to vary across species. As an extreme case, *C. elegans* does not require classical cadherins for the maintenance of their embryonic epithelial junctions, although these are required for fusion processes of cell sheets, indicating that the AJs are necessary only for dynamic aspects of cell-cell contacts, in this species. It is interesting to discover the cell-cell adhesion systems, instead of classical cadherins, that are responsible for stable cell-cell associations in such species.

Genome sequencing of primitive metazoans and their close relatives has opened up the door to understanding the ancestry of the classical cadherins. It is relatively easy to identify candidate genes on the basis of sequence similarity, but is difficult to obtain experimental evidence for their functions in respective species. Continuing efforts are necessary to develop experimental model systems for each species. The final important questions are the following: What were the functions of ancient cadherins before they were co-opted for cell junctional formation? When and how did the extracellular cadherin repeats merge with the cytoplasmic domain containing catenin-binding sequences, the hallmark of the classical cadherins? The latter question is closely relevant to the problem of the origin of multicellular animals. Further analysis of the processes that evolved the cadherin-mediated junctions should provide a clue to give us a deeper understanding of the origin and diversity of metazoans.

Online supplemental material

This paper contains a supplemental figure, available at <http://www.jcb.org/cgi/content/full/jcb.201008173/DC1>.

We thank Paco Hupiau and Frans van Roy for sharing their pre-publication manuscript with us.

Research in the authors' laboratory is supported by the programs Grants-in-Aid for Scientific Research from the Japan Society for Promotion of Science to H.O., and Grants-in-Aid for Specially Promoted Research of the Ministry of Education, Science, Sports, and Culture of Japan to M.T.

Submitted: 30 August 2010

Accepted: 19 May 2011

References

- Abedin, M., and N. King. 2008. The premetazoan ancestry of cadherins. *Science*. 319:946–948. doi:10.1126/science.1151084
- Bellen, H.J., Y. Lu, R. Beckstead, and M.A. Bhat. 1998. Neurexin IV, caspr and paranodin—novel members of the neurexin family: encounters of axons and glia. *Trends Neurosci*. 21:444–449. doi:10.1016/S0166-2236(98)01267-3
- Broadbent, I.D., and J. Pettitt. 2002. The *C. elegans hmr-1* gene can encode a neuronal classic cadherin involved in the regulation of axon fasciculation. *Curr. Biol.* 12:59–63. doi:10.1016/S0960-9822(01)00624-8
- Chapman, J.A., E.F. Kirkness, O. Simakov, S.E. Hampson, T. Mitros, T. Weinmaier, T. Rattei, P.G. Balasubramanian, J. Borman, D. Busam, et al. 2010. The dynamic genome of *Hydra*. *Nature*. 464:592–596. doi:10.1038/nature08830
- Chen, X., and B.M. Gumbiner. 2006. Paraxial protocadherin mediates cell sorting and tissue morphogenesis by regulating C-cadherin adhesion activity. *J. Cell Biol.* 174:301–313. doi:10.1083/jcb.200602062
- Clark, H.F., D. Brentrup, K. Schneitz, A. Bieber, C. Goodman, and M. Noll. 1995. *Drosophila* encodes a member of the cadherin superfamily that controls imaginal disc morphogenesis in *Drosophila*. *Genes Dev.* 9:1530–1542. doi:10.1101/gad.9.12.1530
- Costa, M., W. Raich, C. Agbunag, B. Leung, J. Hardin, and J.R. Priess. 1998. A putative catenin-cadherin system mediates morphogenesis of the *Caenorhabditis elegans* embryo. *J. Cell Biol.* 141:297–308. doi:10.1083/jcb.141.1.297
- Dawes-Hoang, R.E., K.M. Parmar, A.E. Christiansen, C.B. Phelps, A.H. Brand, and E.F. Wieschaus. 2005. *folded gastrulation*, cell shape change and the control of myosin localization. *Development*. 132:4165–4178. doi:10.1242/dev.01938
- Dickinson, D.J., W.J. Nelson, and W.I. Weis. 2011. A polarized epithelium organized by β - and α -catenin predates cadherin and metazoan origins. *Science*. 331:1336–1339. doi:10.1126/science.1199633
- Ereskovsky, A.V., C. Borchellini, E. Gazave, J. Ivanisevic, P. Lapébie, T. Perez, E. Renard, and J. Vacelet. 2009. The Homoscleromorph sponge *Oscarella lobularis*, a promising sponge model in evolutionary and developmental biology: model sponge *Oscarella lobularis*. *Bioessays*. 31:89–97. doi:10.1002/bies.080058
- Fahey, B., and B.M. Degnan. 2010. Origin of animal epithelia: insights from the sponge genome. *Evol. Dev.* 12:601–617. doi:10.1111/j.1525-142X.2010.00445.x
- Farquhar, M.G., and G.E. Palade. 1963. Junctional complexes in various epithelia. *J. Cell Biol.* 17:375–412. doi:10.1083/jcb.17.2.375
- Fritzenwanker, J.H., G. Genikhovich, Y. Kraus, and U. Technau. 2007. Early development and axis specification in the sea anemone *Nematostella vectensis*. *Dev. Biol.* 310:264–279. doi:10.1016/j.ydbio.2007.07.029
- Greenwood, M.D., M.D. Marsden, C.M. Cowley, V.K. Sahota, and R.S. Buxton. 1997. Exon-intron organization of the human type 2 desmocollin gene (DSC2): desmocollin gene structure is closer to “classical” cadherins than to desmogleins. *Genomics*. 44:330–335. doi:10.1006/geno.1997.4894
- Grimson, M.J., J.C. Coates, J.P. Reynolds, M. Shipman, R.L. Blanton, and A.J. Harwood. 2000. Adherens junctions and beta-catenin-mediated cell signalling in a non-metazoan organism. *Nature*. 408:727–731. doi:10.1038/35047099
- Harris, T.J., and U. Tepass. 2010. Adherens junctions: from molecules to morphogenesis. *Nat. Rev. Mol. Cell Biol.* 11:502–514. doi:10.1038/nrm2927
- Harrison, O.J., F. Bahna, P.S. Katsamba, X. Jin, J. Brasch, J. Vendome, G. Ahlsen, K.J. Carroll, S.R. Price, B. Honig, and L. Shapiro. 2010. Two-step adhesive binding by classical cadherins. *Nat. Struct. Mol. Biol.* 17:348–357. doi:10.1038/nsmb.1784
- Haruta, T., R. Warrior, S. Yonemura, and H. Oda. 2010. The proximal half of the *Drosophila* E-cadherin extracellular region is dispensable for many cadherin-dependent events but required for ventral furrow formation. *Genes Cells*. 15:193–208. doi:10.1111/j.1365-2443.2010.01389.x
- Hayashi, T., and R.W. Carthew. 2004. Surface mechanics mediate pattern formation in the developing retina. *Nature*. 431:647–652. doi:10.1038/nature02952
- Hsu, S.N., S. Yonekura, C.Y. Ting, H.M. Robertson, Y. Iwai, T. Uemura, C.H. Lee, and A. Chiba. 2009. Conserved alternative splicing and expression patterns of arthropod N-cadherin. *PLoS Genet*. 5:e1000441. doi:10.1371/journal.pgen.1000441
- Hupiau, P., and F. van Roy. 2009. Molecular evolution of the cadherin superfamily. *Int. J. Biochem. Cell Biol.* 41:349–369. doi:10.1016/j.biocel.2008.09.027
- Hupiau, P., and F. van Roy. 2011. New insights into the evolution of metazoan cadherins. *Mol. Biol. Evol.* 28:647–657. doi:10.1093/molbev/msq233. doi:10.1093/molbev/msq233
- Ishiyuchi, T., K. Misaki, S. Yonemura, M. Takeichi, and T. Tanoue. 2009. Mammalian Fat and Dachous cadherins regulate apical membrane organization in the embryonic cerebral cortex. *J. Cell Biol.* 185:959–967. doi:10.1083/jcb.200811030
- Iwai, Y., T. Usui, S. Hirano, R. Steward, M. Takeichi, and T. Uemura. 1997. Axon patterning requires DN-cadherin, a novel neuronal adhesion receptor, in the *Drosophila* embryonic CNS. *Neuron*. 19:77–89. doi:10.1016/S0896-6273(00)80349-9
- Kan, N.G., M.P. Stemmler, D. Junghans, B. Kanzler, W.N. de Vries, M. Dominis, and R. Kemler. 2007. Gene replacement reveals a specific role for E-cadherin in the formation of a functional trophoblast. *Development*. 134:31–41. doi:10.1242/dev.02722
- Katsamba, P., K. Carroll, G. Ahlsen, F. Bahna, J. Vendome, S. Posy, M. Rajebhosale, S. Price, T.M. Jessell, A. Ben-Shaul, et al. 2009. Linking molecular affinity and cellular specificity in cadherin-mediated adhesion. *Proc. Natl. Acad. Sci. USA*. 106:11594–11599. doi:10.1073/pnas.0905349106
- Kazmierczak, P., H. Sakaguchi, J. Tokita, E.M. Wilson-Kubalek, R.A. Milligan, U. Müller, and B. Kachar. 2007. Cadherin 23 and protocadherin 15 interact to form tip-link filaments in sensory hair cells. *Nature*. 449:87–91. doi:10.1038/nature06091
- Knust, E., and O. Bossinger. 2002. Composition and formation of intercellular junctions in epithelial cells. *Science*. 298:1955–1959. doi:10.1126/science.1072161
- Lane, N.J. 2001. Tight junctions in invertebrates. In *Tight Junctions*, second edition. M. Cerejido and J. Anderson, editors. CRC Press LLC/Boca Raton, Florida, 39–59.
- Lane, N.J., R. Dallai, P. Burighel, and G.B. Martinucci. 1986. Tight and gap junctions in the intestinal tract of tunicates (Urochordata): a freeze-fracture study. *J. Cell Sci.* 84:1–17.
- Lane, N.J., R. Dallai, G.B. Martinucci, and P. Burighel. 1987. Cell junctions in amphioxus (Cephalochordata): a thin section and freeze-fracture study. *Tissue Cell*. 19:399–411. doi:10.1016/0040-8166(87)90035-8
- Le Borgne, R., Y. Bellaïche, and F. Schweisguth. 2002. *Drosophila* E-cadherin regulates the orientation of asymmetric cell division in the sensory organ lineage. *Curr. Biol.* 12:95–104. doi:10.1016/S0960-9822(01)00648-0
- Ledger, P.W. 1975. Septate junctions in the calcareous sponge *Sycon ciliatum*. *Tissue Cell*. 7:13–18. doi:10.1016/S0040-8166(75)80004-8
- Leung, B., G.J. Hermann, and J.R. Priess. 1999. Organogenesis of the *Caenorhabditis elegans* intestine. *Dev. Biol.* 216:114–134. doi:10.1006/dbio.1999.9471
- Lin, Z., S. Sriskanthadevan, H. Huang, C.H. Siu, and D. Yang. 2006. Solution structures of the adhesion molecule DdCAD-1 reveal new insights into Ca^{2+} -dependent cell-cell adhesion. *Nat. Struct. Mol. Biol.* 13:1016–1022. doi:10.1038/nsmb1162
- Ma, D., C.H. Yang, H. McNeill, M.A. Simon, and J.D. Axelrod. 2003. Fidelity in planar cell polarity signalling. *Nature*. 421:543–547. doi:10.1038/nature01366
- Magie, C.R., and M.Q. Martindale. 2008. Cell-cell adhesion in the cnidaria: insights into the evolution of tissue morphogenesis. *Biol. Bull.* 214:218–232. doi:10.2307/25470665
- Maretzky, T., K. Reiss, A. Ludwig, J. Buchholz, F. Scholz, E. Proksch, B. de Strooper, D. Hartmann, and P. Saftig. 2005. ADAM10 mediates E-cadherin shedding and regulates epithelial cell-cell adhesion, migration, and beta-catenin translocation. *Proc. Natl. Acad. Sci. USA*. 102:9182–9187. doi:10.1073/pnas.0500918102
- Martin, A.C., M. Kaschube, and E.F. Wieschaus. 2009. Pulsed contractions of an actin-myosin network drive apical constriction. *Nature*. 457:495–499. doi:10.1038/nature07522
- Matakatsu, H., and S.S. Blair. 2004. Interactions between Fat and Dachous and the regulation of planar cell polarity in the *Drosophila* wing. *Development*. 131:3785–3794. doi:10.1242/dev.01254
- McNutt, N.S., and R.S. Weinstein. 1973. Membrane ultrastructure at mammalian intercellular junctions. *Prog. Biophys. Mol. Biol.* 26:45–101. doi:10.1016/0079-6107(73)90017-5

- Miller, J.R., and D.R. McClay. 1997. Characterization of the role of cadherin in regulating cell adhesion during sea urchin development. *Dev. Biol.* 192:323–339. doi:10.1006/dbio.1997.8740
- Mirkovic, I., and M. Mlodzik. 2006. Cooperative activities of *Drosophila* DE-cadherin and DN-cadherin regulate the cell motility process of ommatidial rotation. *Development.* 133:3283–3293. doi:10.1242/dev.02468
- Nakao, S., A. Platek, S. Hirano, and M. Takeichi. 2008. Contact-dependent promotion of cell migration by the OL-protocadherin-Nap1 interaction. *J. Cell Biol.* 182:395–410. doi:10.1083/jcb.200802069
- Nishimura, T., and M. Takeichi. 2009. Remodeling of the adherens junctions during morphogenesis. *Curr. Top. Dev. Biol.* 89:33–54. doi:10.1016/S0070-2153(09)89002-9
- Oda, H., and S. Tsukita. 1999. Nonchordate classic cadherins have a structurally and functionally unique domain that is absent from chordate classic cadherins. *Dev. Biol.* 216:406–422. doi:10.1006/dbio.1999.9494
- Oda, H., H. Wada, K. Tagawa, Y. Akiyama-Oda, N. Satoh, T. Humphreys, S. Zhang, and S. Tsukita. 2002. A novel amphioxus cadherin that localizes to epithelial adherens junctions has an unusual domain organization with implications for chordate phylogeny. *Evol. Dev.* 4:426–434. doi:10.1046/j.1525-142X.2002.02031.x
- Oda, H., Y. Akiyama-Oda, and S. Zhang. 2004. Two classic cadherin-related molecules with no cadherin extracellular repeats in the cephalochordate amphioxus: distinct adhesive specificities and possible involvement in the development of multicell-layered structures. *J. Cell Sci.* 117:2757–2767. doi:10.1242/jcs.01045
- Oda, H., K. Tagawa, and Y. Akiyama-Oda. 2005. Diversification of epithelial adherens junctions with independent reductive changes in cadherin form: identification of potential molecular synapomorphies among bilaterians. *Evol. Dev.* 7:376–389. doi:10.1111/j.1525-142X.2005.05043.x
- Pokutta, S., K. Herrenknecht, R. Kemler, and J. Engel. 1994. Conformational changes of the recombinant extracellular domain of E-cadherin upon calcium binding. *Eur. J. Biochem.* 223:1019–1026. doi:10.1111/j.1432-1033.1994.tb19080.x
- Prakash, S., J.C. Caldwell, D.F. Eberl, and T.R. Clandinin. 2005. *Drosophila* N-cadherin mediates an attractive interaction between photoreceptor axons and their targets. *Nat. Neurosci.* 8:443–450.
- Putnam, N.H., T. Butts, D.E. Ferrier, R.F. Furlong, U. Hellsten, T. Kawashima, M. Robinson-Rechavi, E. Shoguchi, A. Terry, J.K. Yu, et al. 2008. The amphioxus genome and the evolution of the chordate karyotype. *Nature.* 453:1064–1071. doi:10.1038/nature06967
- Raich, W.B., C. Agbunag, and J. Hardin. 1999. Rapid epithelial-sheet sealing in the *Caenorhabditis elegans* embryo requires cadherin-dependent filopodial priming. *Curr. Biol.* 9:1139–1146. doi:10.1016/S0960-9822(00)80015-9
- Reddy, B.V., and K.D. Irvine. 2008. The Fat and Warts signaling pathways: new insights into their regulation, mechanism and conservation. *Development.* 135:2827–2838. doi:10.1242/dev.020974
- Reiss, K., T. Maretzky, A. Ludwig, T. Tousseyn, B. de Strooper, D. Hartmann, and P. Saftig. 2005. ADAM10 cleavage of N-cadherin and regulation of cell-cell adhesion and beta-catenin nuclear signalling. *EMBO J.* 24:742–752. doi:10.1038/sj.emboj.7600548
- Ruthmann, A., G. Behrendt, and R. Wahl. 1986. The ventral epithelium of *Trichoplax adhaerens* (Placozoa): Cytoskeletal structures, cell contacts and endocytosis. *Zoomorphology.* 106:115–122. doi:10.1007/BF00312113
- Saburi, S., and H. McNeill. 2005. Organising cells into tissues: new roles for cell adhesion molecules in planar cell polarity. *Curr. Opin. Cell Biol.* 17:482–488. doi:10.1016/j.ceb.2005.08.011
- Sakarya, O., K.A. Armstrong, M. Adamska, M. Adamski, I.F. Wang, B. Tidor, B.M. Degnan, T.H. Oakley, and K.S. Kosik. 2007. A post-synaptic scaffold at the origin of the animal kingdom. *PLoS ONE.* 2:e506. doi:10.1371/journal.pone.0000506
- Sasakura, Y., E. Shoguchi, N. Takatori, S. Wada, I.A. Meinertzhagen, Y. Satou, and N. Satoh. 2003. A genomewide survey of developmentally relevant genes in *Ciona intestinalis*. X. Genes for cell junctions and extracellular matrix. *Dev. Genes Evol.* 213:303–313. doi:10.1007/s00427-003-0320-1
- Sesaki, H., E.F. Wong, and C.H. Siu. 1997. The cell adhesion molecule DdCAD-1 in *Dictyostelium* is targeted to the cell surface by a nonclassical transport pathway involving contractile vacuoles. *J. Cell Biol.* 138:939–951. doi:10.1083/jcb.138.4.939
- Spiegel, E., and L. Howard. 1983. Development of cell junctions in sea-urchin embryos. *J. Cell Sci.* 62:27–48.
- Srivastava, M., O. Simakov, J. Chapman, B. Fahey, M.E. Gauthier, T. Mitros, G.S. Richards, C. Conaco, M. Dacre, U. Hellsten, et al. 2010. The *Amphimedon queenslandica* genome and the evolution of animal complexity. *Nature.* 466:720–726. doi:10.1038/nature09201
- Suzuki, S.C., and M. Takeichi. 2008. Cadherins in neuronal morphogenesis and function. *Dev. Growth Differ.* 50(Suppl 1):S119–S130. doi:10.1111/j.1440-169X.2008.01002.x
- Takeichi, M. 1995. Morphogenetic roles of classic cadherins. *Curr. Opin. Cell Biol.* 7:619–627. doi:10.1016/0955-0674(95)80102-2
- Takeichi, M. 2007. The cadherin superfamily in neuronal connections and interactions. *Nat. Rev. Neurosci.* 8:11–20. doi:10.1038/nrn2043
- Takeichi, M., and K. Abe. 2005. Synaptic contact dynamics controlled by cadherin and catenins. *Trends Cell Biol.* 15:216–221. doi:10.1016/j.tcb.2005.02.002
- Tanabe, K., M. Takeichi, and S. Nakagawa. 2004. Identification of a nonchordate-type classic cadherin in vertebrates: chicken Hz-cadherin is expressed in horizontal cells of the neural retina and contains a nonchordate-specific domain complex. *Dev. Dyn.* 229:899–906. doi:10.1002/dvdy.10493
- Tepass, U., and V. Hartenstein. 1994. The development of cellular junctions in the *Drosophila* embryo. *Dev. Biol.* 161:563–596. doi:10.1006/dbio.1994.1054
- Tepass, U., E. Gruszynski-DeFeo, T.A. Haag, L. Omatyar, T. Török, and V. Hartenstein. 1996. *shotgun* encodes *Drosophila* E-cadherin and is preferentially required during cell rearrangement in the neuroectoderm and other morphogenetically active epithelia. *Genes Dev.* 10:672–685. doi:10.1101/gad.10.6.672
- Ting, C.Y., S. Yonekura, P. Chung, S.N. Hsu, H.M. Robertson, A. Chiba, and C.H. Lee. 2005. *Drosophila* N-cadherin functions in the first stage of the two-stage layer-selection process of R7 photoreceptor afferents. *Development.* 132:953–963. doi:10.1242/dev.01661
- Uemura, T., H. Oda, R. Kraut, S. Hayashi, Y. Katoaka, and M. Takeichi. 1996. Zygotic *Drosophila* E-cadherin expression is required for processes of dynamic epithelial cell rearrangement in the *Drosophila* embryo. *Genes Dev.* 10:659–671. doi:10.1101/gad.10.6.659
- Wang, F., K. Dumstrei, T. Haag, and V. Hartenstein. 2004. The role of DE-cadherin during cellularization, germ layer formation and early neurogenesis in the *Drosophila* embryo. *Dev. Biol.* 270:350–363. doi:10.1016/j.ydbio.2004.03.002
- Whittaker, C.A., K.F. Bergeron, J. Whittle, B.P. Brandhorst, R.D. Burke, and R.O. Hynes. 2006. The echinoderm adhesome. *Dev. Biol.* 300:252–266. doi:10.1016/j.ydbio.2006.07.044
- Wong, E.F., S.K. Brar, H. Sesaki, C. Yang, and C.H. Siu. 1996. Molecular cloning and characterization of DdCAD-1, a Ca²⁺-dependent cell-cell adhesion molecule, in *Dictyostelium discoideum*. *J. Biol. Chem.* 271:16399–16408. doi:10.1074/jbc.271.27.16399
- Wong, E., C. Yang, J. Wang, D. Fuller, W.F. Loomis, and C.H. Siu. 2002. Disruption of the gene encoding the cell adhesion molecule DdCAD-1 leads to aberrant cell sorting and cell-type proportioning during *Dictyostelium* development. *Development.* 129:3839–3850.
- Wood, R.L. 1959. Intercellular attachment in the epithelium of *Hydra* as revealed by electron microscopy. *J. Biophys. Biochem. Cytol.* 6:343–352. doi:10.1083/jcb.6.3.343
- Yasuda, S., H. Tanaka, H. Sugiura, K. Okamura, T. Sakaguchi, U. Tran, T. Takemiya, A. Mizoguchi, Y. Yagita, T. Sakurai, et al. 2007. Activity-induced protocadherin arcadin regulates dendritic spine number by triggering N-cadherin endocytosis via TAO2beta and p38 MAP kinases. *Neuron.* 56:456–471. doi:10.1016/j.neuron.2007.08.020
- Yonekura, S., L. Xu, C.Y. Ting, and C.H. Lee. 2007. Adhesive but not signaling activity of *Drosophila* N-cadherin is essential for target selection of photoreceptor afferents. *Dev. Biol.* 304:759–770. doi:10.1016/j.ydbio.2007.01.030