



Since January 2020 Elsevier has created a COVID-19 resource centre with free information in English and Mandarin on the novel coronavirus COVID-19. The COVID-19 resource centre is hosted on Elsevier Connect, the company's public news and information website.

Elsevier hereby grants permission to make all its COVID-19-related research that is available on the COVID-19 resource centre - including this research content - immediately available in PubMed Central and other publicly funded repositories, such as the WHO COVID database with rights for unrestricted research re-use and analyses in any form or by any means with acknowledgement of the original source. These permissions are granted for free by Elsevier for as long as the COVID-19 resource centre remains active.

# Impact of High-Dose Prophylactic Anticoagulation in Critically Ill Patients With COVID-19 Pneumonia



Charles Tacquard, MD; Alexandre Mansour, MD; Alexandre Godon, MD; Julien Godet, PharmD, PhD; Julien Poissy, MD, PhD; Delphine Garrigue, MD, PhD; Eric Kipnis, MD, PhD; Sophie Rym Hamada, MD, PhD; Paul Michel Mertes, MD, PhD; Annick Steib, MD, PhD; Mathilde Ulliel-Roche, MD; Bélaïd Bouhemad, MD, PhD; Maxime Nguyen, MD; Florian Reizine, MD; Isabelle Gouin-Thibault, MD, PhD; Marie Charlotte Besse, MD; Nived Collercandy, MD; Stefan Mankikian, MD; Jerrold H. Levy, MD, PhD; Yves Gruel, MD, PhD; Pierre Albaladejo, MD, PhD; Sophie Susen, MD, PhD; Anne Godier, MD, PhD; and the French Working Group on Perioperative Hemostasis\*



**BACKGROUND:** Because of the high risk of thrombotic complications (TCs) during SARS-CoV-2 infection, several scientific societies have proposed to increase the dose of preventive anticoagulation, although arguments in favor of this strategy are inconsistent.

**RESEARCH QUESTION:** What is the incidence of TC in critically ill patients with COVID-19 and what is the relationship between the dose of anticoagulant therapy and the incidence of TC?

**STUDY DESIGN AND METHODS:** All consecutive patients referred to eight French ICUs for COVID-19 were included in this observational study. Clinical and laboratory data were collected from ICU admission to day 14, including anticoagulation status and thrombotic and hemorrhagic events. The effect of high-dose prophylactic anticoagulation (either at intermediate or equivalent to therapeutic dose), defined using a standardized protocol of classification, was assessed using a time-varying exposure model using inverse probability of treatment weight.

**RESULTS:** Of 538 patients included, 104 patients experienced a total of 122 TCs with an incidence of 22.7% (95% CI, 19.2%-26.3%). Pulmonary embolism accounted for 52% of the recorded TCs. High-dose prophylactic anticoagulation was associated with a significant reduced risk of TC (hazard ratio, 0.81; 95% CI, 0.66-0.99) without increasing the risk of bleeding (HR, 1.11; 95% CI, 0.70-1.75).

**INTERPRETATION:** High-dose prophylactic anticoagulation is associated with a reduction in thrombotic complications in critically ill patients with COVID-19 without an increased risk of hemorrhage. Randomized controlled trials comparing prophylaxis with higher doses of anticoagulants are needed to confirm these results.

**TRIAL REGISTRY:** ClinicalTrials.gov; No.: NCT04405869; URL: [www.clinicaltrials.gov](http://www.clinicaltrials.gov)

CHEST 2021; 159(6):2417-2427

**KEY WORDS:** anticoagulation; bleeding; COVID-19; thrombosis

FOR EDITORIAL COMMENT, SEE PAGE 2151

**ABBREVIATIONS:** DOAC = direct oral anticoagulant; ECMO = extracorporeal membrane oxygenation; HPA = high-dose prophylactic anticoagulation; HR = hazard ratio; IQR = interquartile range; LMWH = low-molecular-weight heparin; TC = thrombotic complication; UFH = unfractionated heparin; VKA = vitamin K antagonist; VTE = venous thromboembolic event

**AFFILIATIONS:** From the Department of Anesthesiology and Intensive Care (C. Tacquard, P. M. Mertes, and A. Steib), the Groupe Méthodes

en Recherche Clinique (J. Godet), Hôpital Civil, Hôpitaux Universitaires de Strasbourg, Strasbourg, the Department of Anesthesiology Critical Care Medicine and Perioperative Medicine (A. Mansour), CHU de Rennes, the Service des Maladies Infectieuses et Réanimation Médicale (F. Reizine), the Department of Hematology-Hemostasis (I. Gouin-Thibault), Rennes University Hospital, Rennes, the Department of Anesthesiology and Critical Care (A. Godon, M. Ulliel-Roche, and P. Albaladejo), Grenoble Alpes University

## Take-home Point

The incidence of thrombotic complications is high in critically ill patients with COVID-19. The use of high-dose prophylactic anticoagulation is associated with a reduction in thrombotic risk without increasing the risk of bleeding.

Patients with severe pneumonia resulting from SARS-CoV-2 infection admitted to ICUs have high rates of thrombotic complications (TCs), particularly pulmonary embolism. According to several studies, the proportion of hospitalized patients experiencing TCs ranges from 18% to 37%, despite the use of regular prophylactic anticoagulation.<sup>1</sup> The risk of TC seems to

be particularly high in critically ill patients admitted to ICUs.<sup>2-5</sup>

Although standard pharmacologic thromboprophylaxis is recommended in hospitalized patients, several expert groups have proposed to increase anticoagulant dosing in critically ill patients with COVID-19.<sup>6</sup> In particular, the French Working Group on Perioperative Hemostasis and the French Study Group on Thrombosis and Hemostasis have proposed to increase the dose of anticoagulant progressively based on thrombotic risk factors that include obesity, high oxygen demand, need for mechanical ventilation, and biomarkers of major inflammation or hypercoagulability, despite the lack of evidence supporting this strategy.<sup>7</sup> We aimed to study the incidence of TCs and bleeding in critically ill patients with COVID-19 and to examine their relationship to the dose of prophylactic anticoagulation administered.

## Methods

### Study Design and Participants

We conducted a retrospective chart review of all consecutive adult patients admitted to eight French ICUs for severe laboratory-confirmed COVID-19 pneumonia between March 21 and April 10, 2020. The protocol was approved by the University Hospital of Strasbourg Ethics Committee (Reference: CE-2020-76) and was

registered at [ClinicalTrials.gov](https://clinicaltrials.gov) (Identifier: NCT04405869). Partial data from 32 patients from the University Hospital of Strasbourg and 107 patients from the University Hospital of Lille were published previously.<sup>5,8</sup>

Demographic characteristics and relevant comorbidities were collected at admission (day 0). Data regarding clinical management, pharmacologic thromboprophylaxis, laboratory results, and thrombotic and bleeding events were collected for each patient from ICU admission and up to 14 days of follow-up in the ICU at six prespecified time points (day 1, day 2, day 5, day 8, day 11, and day 14), defining six different periods of evaluation: admission to day 1, day 1 to day 2, day 2 to day 5, day 5 to day 8, day 8 to day 11, and day 11 to day 14, according to the seven predefined time points. For study purposes, we considered that a patient received pharmacologic thromboprophylaxis during one specific period of evaluation if prophylaxis was reported on the first and last day of that specific period.

### Thromboprophylaxis Management and Anticoagulation Use Reporting

All patients received pharmacologic thromboprophylaxis for at least one period of evaluation defined as the time between two assessment points. Pharmacologic thromboprophylaxis was prescribed according to the national guidelines and local protocols of each ICU. Standard prophylaxis initially was recommended using either low-molecular-weight heparin (LMWH) or unfractionated heparin (UFH) with dosage adjustments for overweight and obese patients.<sup>9</sup> Then, after the French Working Group on Perioperative Hemostasis and French Study Group on Thrombosis and Hemostasis published their guidance document (*e-Table 1*) on April 3, 2020, doses of thromboprophylaxis were increased according to different risk factors: BMI > 30 kg/m<sup>2</sup>, known risk factor for VTE (active cancer, recent personal history of thrombosis, and so forth), catheter or iterative filter coagulation, severe inflammatory syndrome (eg, fibrinogen > 8 g/L), hypercoagulable state (eg, D-dimer > 3.0 µg/mL), long-term anticoagulant therapy, and extracorporeal membrane oxygenation (ECMO). The severity of COVID-19 pneumonia, defined by high-flow nasal canula or invasive ventilation requirement, also was a

Hospital, Grenoble, the University of Lille (J. Poissy), Inserm U1285, CHU Lille, Pôle de Réanimation, CNRS, UMR 8576 - UGSF - Unité de Glycobiologie Structurale et Fonctionnelle, the Department of Anesthesiology and Critical Care (D. Garrigue), Surgical Critical Care, Centre Hospitalier Universitaire Lille, the University of Lille (E. Kipnis), CNRS, Inserm, CHU Lille, Surgical Critical Care, Department of Anesthesiology and Critical Care, Institut Pasteur de Lille, U1019—UMR 9017—CIIL—Center for Infection and Immunity of Lille, the Hemostasis Department (S. Susen), Heart and Lung Institute, CHU Lille, Lille, the Department of Anesthesiology and Critical Care (S. Rym Hamada and A. Godier), European Georges Pompidou Hospital, Assistance Publique-Hôpitaux de Paris, Paris University, Paris, the Department of Anesthesiology and Intensive Care (B. Bouhemad and M. Nguyen), Dijon University Hospital and University of Burgundy, Lipness Team, INSERM Research Center LNC-UMR1231 and LabExLipSTIC, Dijon, the Service de Médecine Intensive—Réanimation (M. C. Besse, N. Collescandy, and S. Mankikian), Tours University Hospital, the Department of Hematology-Hemostasis (Y. Gruel), Tours University Hospital, Tours, France; and the Departments of Anesthesiology, Critical Care, and Surgery (J. H. Levy), Duke University School of Medicine, Durham, NC.

\*Collaborators from the French Working Group on Perioperative Hemostasis are listed in the Acknowledgments.

**FUNDING/SUPPORT:** This study was supported by the University Hospital of Strasbourg (Hôpitaux Universitaires de Strasbourg—Direction de la Recherche Clinique et des Innovations).

**CORRESPONDENCE TO:** Sophie Susen, MD, PhD; e-mail: [sophiesusen@aol.com](mailto:sophiesusen@aol.com)

Copyright © 2021 American College of Chest Physicians. Published by Elsevier Inc. All rights reserved.

**DOI:** <https://doi.org/10.1016/j.chest.2021.01.017>

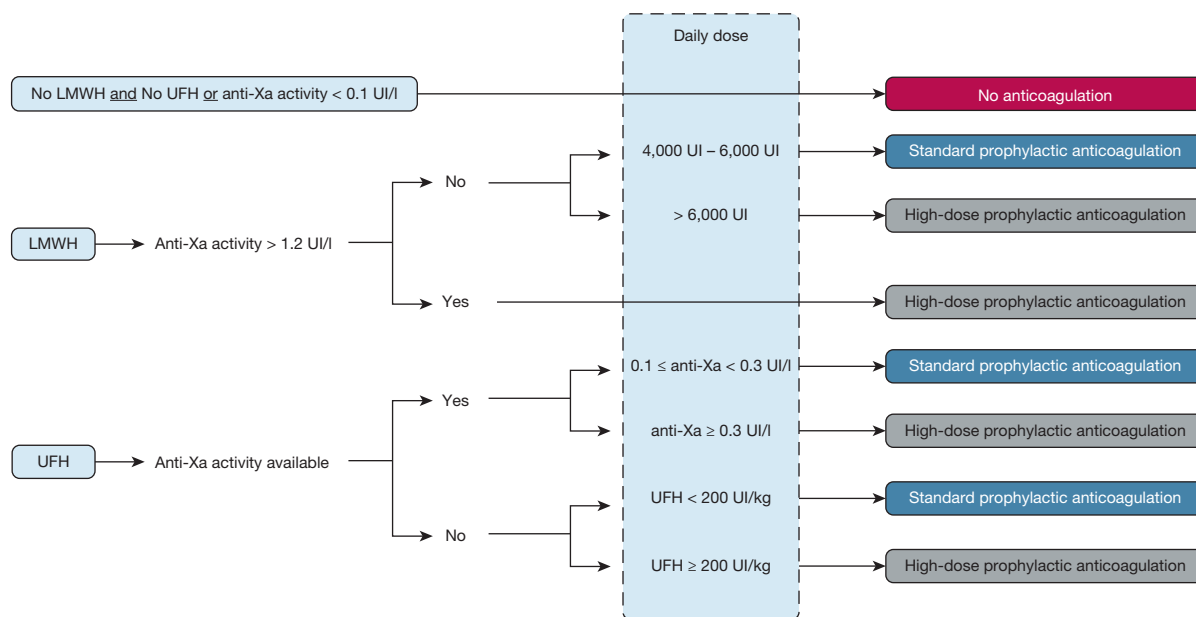

Figure 1 – Diagram showing retrospective classification of the level of anticoagulation for thromboprophylaxis. This algorithm was used at each time point to classify the patient into either standard or high-dose prophylactic anticoagulation. A patient could change category between two time points several times during the study period. LWMH = low-molecular-weight heparin; UFH = unfractionated heparin.

factor in increasing the anticoagulation dose. Because the study period ranges from March 21 to April 10, 2020, the doses of prophylactic anticoagulation increased during this period, according to national guidelines, allowing us to compare the two strategies.

We retrospectively classified the level of anticoagulation for thromboprophylaxis at each time point into two groups according to the anticoagulant and the dose: standard prophylactic anticoagulation or high prophylactic anticoagulation (which included intermediate- and therapeutic-dose anticoagulation) (Fig 1). For UFH, the level of anticoagulation was defined in terms of anti-Xa activity (when available), which is more accurate than the reported administered dose because the response to UFH is subject to high interpersonal variability. Cumulative treatment coverage then was expressed as the number of evaluation periods covered by anticoagulation before the occurrence of a thrombotic event.

### Thrombotic and Bleeding Outcomes

Recorded TCs included pulmonary embolism, DVT, catheter thrombosis (within the first 24 h after insertion or recurrent), stroke, mesenteric infarction, myocardial infarction, dialysis filter coagulation, or ECMO thrombosis. No specific screening policy was implemented. Bleeding complications were included based on International Society on Thrombosis and Haemostasis guidelines, and severity was classified according to the Global Use of Strategies to Open Occluded Arteries scale.<sup>10</sup> Patients could be reported only once for each type of thrombotic or hemorrhagic event. Two different thrombotic or hemorrhagic events, for example, pulmonary embolism and stroke, were considered to be two different types of events, and therefore several events could be reported in the same patient.

### Statistical Analysis

Categorical variables were described by their count and percentage and were compared using the Pearson  $\chi^2$  or Fisher exact tests. Continuous variables were described by their medians with interquartile ranges (IQRs) and were compared using nonparametric Wilcoxon tests.

ORs and their 95 % CIs were calculated using logistic regressions to evaluate risk factors for thrombotic complications. A multivariate logistic regression model was used on predictor variables selected from a stepwise model selection based on Akaike information criterion. The selection of variables for the multivariate analysis was based on known risk factors for venous thromboembolic event (VTE) and COVID-19 pneumonia severity markers.

To account for the nonrandomized administration of high-dose prophylactic anticoagulation and to reduce the effects of confounding factors, the effect of high-dose prophylactic anticoagulation on thrombotic complications was analyzed with a time-varying exposure model using an inverse probability of treatment weight that allows modelling intermittent treatment exposure.<sup>11,12</sup> Inverse probability treatment weighting was evaluated using a survival model by using age, sex, BMI, smoking status, cardiovascular history, and history of long-term anticoagulant treatment as fixed covariates and sequential organ failure assessment score and D-dimers as time-varying covariates. These variables were selected based on the individual propensities for receiving a high-dose prophylactic anticoagulation. Inverse probability treatment weighting was used to generate a balanced pseudopopulation of patients. Cox proportional hazards regression analysis was used on this pseudopopulation to compare thrombotic complication-free survival as a function of time spent receiving high-dose prophylactic anticoagulation. *P* values < .05 were considered to be statistically significant. All the analyses were performed using R version 4.0.2 software (R Foundation for Statistical Computing).

**TABLE 1 ] Characteristics of the Study Population**

Characteristic	Overall	No TC <sup>a</sup>	TC <sup>b</sup>	P Value
No.	538	417	121	. . .
Age, y	63 (55-71)	63 (55-71)	62 (56-71)	.47
Sex, male	389 (72.4)	303 (72.7)	86 (71.1)	.73
BMI	29.0 (26.0-33.0)	29.0 (25.0-33.0)	29.0 (26.0-33.0)	.52
<b>Medical history</b>				
Hypertension	275 (51.1)	215 (51.6)	60 (49.6)	.76
Diabetes	139 (25.8)	104 (24.9)	35 (28.9)	.41
Smoking	29 (5.4)	22 (5.3)	7 (5.8)	.82
Alcohol	11 (2.0)	7 (1.7)	4 (3.3)	.48
COPD	18 (5.0)	13 (3.1)	5 (4.1)	.79
Heart failure	40 (7.4)	35 (8.4)	5 (4.1)	.17
Coronary artery disease	67 (12.5)	57 (13.7)	10 (8.3)	.12
Atrial fibrillation	25 (4.6)	23 (5.5)	2 (1.6)	.05
Peripheral arterial disease	27 (5.0)	25 (6.0)	2 (1.6)	.06
Stroke	24 (4.5)	20 (4.8)	4 (3.3)	.62
Chronic kidney disease	37 (6.9)	30 (7.2)	7 (5.8)	.69
VTE	16 (3.0)	12 (2.9)	4 (3.3)	1.00
Active cancer	36 (6.7)	29 (7.0)	7 (5.8)	.84
Cirrhosis	5 (0.9)	2 (0.5)	3 (2.5)	.08
Autoimmune disease	22 (4.1)	16 (3.8)	6 (5.0)	.60
Thrombophilia	2 (0.4)	1 (0.2)	1 (0.8)	.40
<b>Chronic medications</b>				
Aspirin	96 (17.8)	78 (18.7)	18 (14.9)	.42
Clopidogrel	15 (2.8)	15 (3.6)	0 (0.0)	.03
VKA	12 (2.2)	9 (2.2)	3 (2.5)	.74
DOAC	28 (5.2)	24 (5.8)	4 (3.3)	.36
<b>ICU management</b>				
Delay first clinical signs or ICU admission	8 (6-10)	8 (6-11)	8 (6-10)	.24
SOFA score at ICU admission	4 (2-8)	4 (2-8)	5 (3-9)	.01
Pao <sub>2</sub> to Fio <sub>2</sub> ratio <sup>c</sup>	93 (71-126)	95 (75-133)	85 (64-110)	< .01
ECMO	44 (8.2)	25 (6.0)	19 (15.7)	< .01
RRT	58 (10.8)	32 (7.7)	26 (21.5)	< .01
Duration of mechanical ventilation over 14 d	236 (43.9)	155 (37.2)	81 (66.9)	< .01
<b>Outcome</b>				
Patients alive at d 14	430 (88.1)	331 (89)	99 (85.3)	.37

Data are presented as No. (%) or median (interquartile range), unless otherwise indicated. DOAC = direct oral anticoagulant therapy; ECMO = extracorporeal membrane oxygenation; RRT = renal replacement therapy; SOFA = sequential organ failure assessment; TC = thrombotic complication; VKA = vitamin K antagonist.

<sup>a</sup>TC diagnosed within the first two weeks of ICU hospitalization.

<sup>b</sup>No TC diagnosed in the first two weeks of ICU hospitalization.

<sup>c</sup>Lower value during ICU stay.

## Results

### Description of the Population

A total of 538 ICU patients with confirmed COVID-19 pneumonia were included. Table 1 summarizes patient characteristics. They were mostly men ( $n = 389$  [72%]), with a median age of 63 years (IQR, 55-71 years) and increased BMI ( $29 \text{ kg/m}^2$ ; IQR, 26-33  $\text{kg/m}^2$ ). The lowest  $\text{PaO}_2$  to  $\text{FiO}_2$  ratio within the ICU stay was 93 mm Hg (IQR, 71-126 mm Hg), and 44 patients (8%) were treated with ECMO support. The sequential organ failure assessment score at ICU admission was 4 (IQR, 2-8).

### Laboratory Results

At ICU admission, patients showed high fibrinogen levels of 6.9 g/L (IQR, 5.9-7.8 g/L), high D-dimer levels of 1.56 mg/L (IQR, 1.00-3.37 mg/L), and high factor VIII and von Willebrand factor antigen levels of 262 UI/dL (IQR, 157-299 UI/dL) and 395 (IQR, 295-453 UI/dL), respectively. Activated partial thromboplastin time ratio, international normalized ratio, and platelet count were  $1.10 \times 10^9/\text{L}$  (IQR,  $1.01$ - $1.26 \times 10^9/\text{L}$ ),  $1.12 \times 10^9/\text{L}$  (IQR,  $1.07$ - $1.23 \times 10^9/\text{L}$ ), and  $226 \times 10^9/\text{L}$  (IQR, 169-290  $\times 10^9/\text{L}$ ), respectively, on ICU admission. The evolution of coagulation parameters within the first two weeks is shown in e-Figure 1.

### TCs

The overall incidence of TC was 22.7% (95% CI, 19.2-26.3). During the first two weeks of ICU hospitalization,

104 patients experienced a total of 122 TCs within a median of 6 days (IQR, 2.5-9 days) after ICU admission. The types of TCs and their respective incidences are shown in Table 2. The incidence of TC was particularly high in patients receiving continuous renal replacement therapy or who were supported by ECMO, with an incidence of thrombotic events of 44.8% (95% CI, 32.4%-57.5%) and 43.2% (95% CI, 29.2%-57.7%), respectively. Conversely, the incidence of TC in patients who received neither continuous renal replacement therapy nor ECMO support was 16.5% (95% CI, 13.0%-20.2%). Risk factors for TC are shown in Table 3. At ICU admission, D-dimer levels were significantly higher in patients who experienced a TC (2.59 mg/L [95% CI, 1.30-7.72 mg/L]) than in those who did not (1.5 mg/L [95% CI, 0.99-2.97 mg/L];  $P < .001$ ) and remained significantly higher during the first two weeks in the ICU ( $P < .05$  on days 2, 5, 8, 11, and 14) (e-Fig 2).

### Effect of Prophylactic Anticoagulation on Thrombotic Complications

Cumulative exposure to higher prophylactic anticoagulation dosing was associated significantly with a reduction in the risk of TC (hazard ratio [HR], 0.79 [95% CI, 0.65-0.95];  $P = .014$ ) (Table 4). Detail of the cumulative exposure for each period is shown in e-Figure 3. This effect was unchanged after adjusting for  $\text{PaO}_2$  to  $\text{FiO}_2$  ratio, continuous renal replacement therapy, and ECMO support (HR, 0.80 [95% CI, 0.65-

**TABLE 2 ]** Thrombotic Complications and Their Respective Cumulative Incidence Within the First Two Weeks of Hospitalization in the ICU

Type of Thrombosis	No. (%)	Cumulative Incidence <sup>a</sup>
All thrombosis	122 (100)	22.7 (19.2-26.3) <sup>b</sup>
Pulmonary embolism	64 (52)	12.0 (9.2-14.7) <sup>b</sup>
DVT	18 (15)	5.0 (2.7-7.3) <sup>c</sup>
Catheter thrombosis	14 (11)	3.9 (1.9-5.9) <sup>c</sup>
Stroke	4 (3)	1.1 (0.1-2.2) <sup>c</sup>
Other thrombosis	2 (2)	0.5 (0.0-1.3) <sup>c</sup>
Mesenteric infarction	1 (2)	0.2 (0.0-1.0) <sup>c</sup>
Myocardial infarction	1 (1)	0.2 (0.0-0.8) <sup>c</sup>
RRT filter clotting	13 (11)	22.8 (11.8-33.7) <sup>c,d</sup>
ECMO clotting	5 (4)	11.6 (1.9-21.3) <sup>c,e</sup>

Data are presented as percentage (95% CI) unless otherwise indicated. ECMO = extracorporeal membrane oxygenation; RRT = renal replacement therapy. <sup>a</sup>Having a TC diagnosed within the first two weeks of hospitalization in the ICU. Incidences were estimated considering discharge from ICU or transfer and death as competing risks.

<sup>b</sup>Calculated using the global population (538 patients).

<sup>c</sup>Calculated using 360 patients because one center did not record these complications.

<sup>d</sup>Calculated using patients receiving RRT.

<sup>e</sup>Calculated using patients receiving ECMO support.

**TABLE 3 ] Risk Factors for TCs in Critically Ill Patients With COVID-19**

Variable	Univariate Analysis		Multivariate Analysis	
	OR (95% CI)	P Value	OR (95% CI)	P Value
Age	0.99 (0.97-1.01)	.38	— <sup>b</sup>	...
BMI	1.00 (0.97-1.03)	.99	— <sup>b</sup>	...
History of VTE	1.05 (0.29-3.16)	.94	— <sup>b</sup>	...
Active cancer	1.06 (0.29-3.05)	.93	— <sup>b</sup>	...
Antiplatelet therapy	0.65 (0.36-1.10)	.12	— <sup>b</sup>	...
Oral anticoagulant	0.71 (0.28-1.56)	.42	—	...
D-dimers level at ICU admission	1.62 (1.27-2.06)	< .01	1.45 (1.10-1.91)	.01
Fibrinogen level at ICU admission	0.93 (0.81-1.08)	.35	— <sup>b</sup>	...
PaO <sub>2</sub> to FiO <sub>2</sub> ratio <sup>a</sup>	0.99 (0.98-0.99)	< .01	0.99 (0.98-0.99)	.04
RRT	3.37 (1.90-5.95)	< .01	— <sup>b</sup>	...
ECMO	2.88 (1.50-5.46)	< .01	2.35 (0.99-5.57)	< .05

ECMO = extracorporeal membrane oxygenation; RRT = renal replacement therapy; VTE = venous thromboembolic event.

<sup>a</sup>Lower value during ICU stay.

<sup>b</sup>Results not statistically significant.

0.99];  $P = .040$ ). Cumulative exposure to high-dose prophylactic anticoagulation also was associated significantly with a reduction in the risk of pulmonary embolism (HR, 0.72 [95% CI, 0.53-0.98];  $P = .037$ ). The evolution of the actual use of anticoagulation (UFH or LMWH) during the first two weeks of hospitalization in the ICU is shown in [e-Table 2](#). Cumulative exposure to higher prophylactic anticoagulation dosing was not associated with reduced mortality at day 14 (HR, 1.12 [95% CI, 0.78-1.62]).

### Bleeding Complications

During the same period, 39 patients (7.2%) experienced a total of 53 bleeding complications within a median of 9 days (IQR, 5-12 days) after ICU admission. Among these bleeding complications, 12 (22.6 %) were considered to be severe according to the Global Use of Strategies to Open Occluded Arteries scale ([e-Table 3](#)). Data on the level of anticoagulation at the onset of bleeding are unavailable for 38.5% of bleeding events. Nineteen bleeding events occurred in patients receiving ECMO support ( $n = 13$  patients). BMI (OR, 0.87 [95% CI, 0.78-0.97];  $P = .02$ ) and ECMO support (OR, 6.26 [95% CI, 2.31-17.01];  $P < .001$ ) were associated significantly with a higher bleeding risk. Exposure to higher prophylactic dosing within the 24 h before the event was not associated with an increased bleeding risk compared with standard dosing (HR, 0.63 [95% CI, 0.28-1.44]), nor was the cumulative exposure to higher dosing (HR, 1.11 [95% CI, 0.70-1.75]). The type of

bleeding and anticoagulation status during or just before the bleeding are shown in [e-Table 3](#).

### Discussion

To our knowledge, this is one of the largest studies to evaluate the effect of higher-dosing prophylactic anticoagulation on TC in critically ill patients with COVID-19. Our results indicate that exposure to higher dosing was associated significantly with a reduced risk of TC. In our study, 22.7% of patients experienced at least one TC in the first two weeks of ICU hospitalization that were clinically relevant and primarily pulmonary embolism in 52% of the patients with TC. This high incidence of pulmonary embolism is consistent with previous reports, including a French prospective cohort of ICU patients diagnosing TC in 42.7% of patients, of whom 16.7% had pulmonary embolism. These TCs occurred despite the routine use of prophylactic anticoagulation, even at therapeutic doses for 30% of the patients.<sup>5</sup> In Europe, Klok et al<sup>2</sup> reported a cumulative incidence of TC of 31% in the ICU, despite routine pharmacologic thromboprophylaxis. Middeldorp et al<sup>4</sup> found a cumulative incidence of VTEs of 48% after 14 days in ICU patients with a systematic screening approach.

Thromboses are important in influencing outcomes in patients with COVID-19. Indeed, Middeldorp et al<sup>4</sup> found that the occurrence of VTE in patients with COVID-19 was associated significantly with death

**TABLE 4 ] Summary of Cox Model for the Effect of High-Dose Prophylactic Anticoagulation on TCs**

Population	Model	Factor	Coefficient (SE)	HR (95% CI)	P Value	
TC all thrombosis (53 events, 1,104 observations, 245 patients)	Univariate Cox model					
		HPA	-0.243 (0.112)	0.785 (0.646-0.952)	.01	
	Adjusted Cox model					
		HPA	-0.208 (0.115)	0.813 (0.663-0.996)	.05	
		RRT	0.687 (0.308)	1.988 (1.083-3.648)	.03	
		ECMO	0.254 (0.401)	1.290 (0.577-2.881)	.54	
	Weighted Cox model					
		PaO <sub>2</sub> to FiO <sub>2</sub> ratio	-0.002 (0.004)	0.998 (0.989-1.007)	.69	
		HPA	-0.332 (0.152)	0.718 (0.532-0.967)	.03	
	Weighted and Adjusted Cox model					
		HPA	-0.217 (0.112)	0.804 (0.653-0.990)	.04	
		RRT	0.671 (0.308)	1.957 (1.056-3.627)	.03	
		ECMO	0.173 (0.405)	1.189 (0.514-2.751)	.69	
PaO <sub>2</sub> to FiO <sub>2</sub> ratio		-0.002 (0.004)	0.998 (0.989-1.007)	.64		
All TCs excluding RRT filter clotting or ECMO circuit clotting (45 events, 1,086 observations, 245 patients)	Univariate Cox model					
		HPA	-0.234 (0.118)	0.791(0.628-0.997)	.04	
	Adjusted Cox model					
		HPA	-0.220 (0.139)	0.801 (0.632-1.017)	.07	
		RRT	0.301 (0.378)	1.352 (0.644-2.839)	.43	
		ECMO	0.048 (0.516)	1.049 (0.381-2.885)	.93	
	Weighted Cox model					
		PaO <sub>2</sub> to FiO <sub>2</sub> ratio	-0.001 (0.005)	0.999 (0.989-1.010)	.87	
		HPA	-0.256 (0.125)	0.774 (0.612-0.980)	.03	
	Weighted and Adjusted Cox model					
		HPA	-0.245 (0.127)	0.783 (0.614-0.997)	.04	
		RRT	0.313 (0.360)	1.367 (0.648-2.886)	.41	
		ECMO	-0.039 (0.497)	0.961 (0.341-2.714)	.94	
PaO <sub>2</sub> to FiO <sub>2</sub> ratio		-0.001 (0.004)	0.999 (0.990-1.008)	.85		

(Continued)



**TABLE 4 ] (Continued)**

Population	Model	Factor	Coefficient (SE)	HR (95% CI)	P Value	
Pulmonary embolism or venous thromboembolism (35 events, 1,086 observations, 245 patients)	Univariate Cox model					
		HPA	-0.298 (0.144)	0.742(0.568-0.969)	.03	
	Adjusted Cox model					
		HPA	-0.286 (0.139)	0.751 (0.572-0.987)	.04	
		RRT	0.333 (0.424)	1.395 (0.607-3.207)	.43	
		ECMO	0.062 (0.583)	1.064 (0.340-3.333)	.92	
	Weighted Cox model					
		HPA	-0.312 (0.139)	0.732 (0.560-0.957)	.02	
		Weighted and Adjusted Cox model				
			HPA	-0.303 (0.141)	0.739 (0.561-0.973)	.03
	RRT		0.365 (0.400)	1.441 (0.624-3.327)	.39	
	Weighted and Adjusted Cox model					
		ECMO	-0.036 (0.551)	0.964 (0.300-3.107)	.95	
		PaO <sub>2</sub> to FiO <sub>2</sub> ratio	0.001 (0.005)	1.001 (0.991-1.010)	.91	
Pulmonary embolism (30 events, 1,086 observations, 245 patients)	Univariate Cox model					
		HPA	-0.311 (0.158)	0.733 (0.544-0.987)	.04	
	Adjusted Cox model					
		HPA	-0.300 (0.161)	0.740 (0.546-1.003)	.05	
		RRT	0.315 (0.442)	1.371 (0.553-3.398)	.50	
		ECMO	-0.223 (0.631)	0.799 (0.221-2.889)	.73	
	Weighted Cox model					
		PaO <sub>2</sub> to FiO <sub>2</sub> ratio	-0.005 (0.006)	0.995 (0.984-1.005)	.30	
		Weighted and Adjusted Cox model				
			HPA	-0.332 (0.153)	0.717 (0.532-0.967)	.03
	Weighted and Adjusted Cox model					
		HPA	-0.325 (0.155)	0.722 (0.531-0.981)	.04	
		RRT	0.356 (0.425)	1.427 (0.572-3.563)	.47	
ECMO		-0.312 (0.632)	0.731 (0.196-2.735)	.64		
		PaO <sub>2</sub> to FiO <sub>2</sub> ratio	-0.004 (0.006)	0.995 (0.985-1.006)	.39	

ECMO = extracorporeal membrane oxygenation; HPA = high-dose prophylactic anticoagulation; HR = hazard ratio; RRT = renal replacement therapy; TC = thrombotic complication.

(adjusted HR, 2.9; 95% CI, 1.02-8.0). Similar results were observed in a retrospective study of 3,334 patients hospitalized in New York City for COVID-19 in which thrombosis was associated independently with death (HR, 1.82; 95% CI, 1.54-2.15).<sup>13</sup>

To address the high thrombotic risk, many experts and national societies empirically have intensified prophylaxis to high prophylactic doses, particularly in obese and critically ill patients. For example, Dutch intensivists have increased anticoagulation dosing with a double dose of LMWH (nadroparin).<sup>2,4</sup> In France, on April 3, 2020, the French Working Group on Perioperative Hemostasis and the French Study Group on Thrombosis and Hemostasis published a guidance document defining four levels of thromboembolic risk based on clinical criteria, biomarkers, and VTE risk factors. As a result, they suggested administering heparin at standard doses in noncritically ill patients without risk factors for thrombosis or at a high dose for critically ill patients (intermediate or therapeutic doses).<sup>7</sup> In our study, patients from March 21 April 10, 2020, were evaluated, so the anticoagulation level increased gradually during this period, allowing us to compare the two strategies.

At least two other studies support the use of an increased dose of anticoagulant for prophylaxis. In an American retrospective study of 2,773 hospitalized patients with COVID-19, Paranjpe et al<sup>14</sup> suggested that systemic treatment-dose anticoagulation could improve outcomes. A more recent study comparing an intermediate dosage of LMWH to a standard prophylactic dosage of LMWH reported that the intermediate dosage was associated with a reduction of in-hospital mortality (5.8% vs 18.8%;  $P = .02$ ). However, this study did not focus on critically ill patients, and groups were not strictly comparable.<sup>15</sup> Thus, a lack of evidence exists to recommend a high-dose anticoagulant strategy. We found that cumulative exposure to higher-dosing prophylactic anticoagulation was associated significantly with reduced risk of TC, with an HR of 0.80 (95% CI, 0.65-0.99), which underscores the potential beneficial impact of a higher dosing strategy in critically ill patients with COVID-19.

In our study, laboratory data suggested an initial procoagulant profile with hyperinflammation, characterized by increased levels of D-dimer, fibrinogen, factor VIII, and von Willebrand factor antigen. Interestingly, the evolution of biomarkers was biphasic, with an initial increase, then a slight decrease. TCs mainly occurred during the first phase, whereas bleeding

complications were reported mainly during the second phase (e-Fig 1). Therefore, prophylactic anticoagulation may be adjusted according to the evolution of inflammation.

Our study highlights that TC risk factors in the COVID-19 context do not include traditional thromboembolic risk factors, but rather severity of COVID-19 pneumonia. Severe hypoxemia, defined according to  $Pao_2$  to  $Fio_2$  ratio (and ECMO requirement) as well as inflammation and hypercoagulability, characterized by high levels of D-dimers, were independent risk factors for TC. Zhang et al<sup>16</sup> also found that an elevated pneumonia severity score (CURB-65 [confusion, urea, respiratory rate, BP, age > 65]) and a D-dimer of > 1  $\mu\text{g/mL}$  were associated independently with an increased risk of thrombosis. Similarly, Bilaloglu et al<sup>13</sup> identified higher D-dimer levels at hospital presentation as a risk factor for arterial or venous thrombosis. Although obesity has been described as a risk factor for SARS-CoV-2 infection,<sup>17</sup> our results did not show an increased risk of TCs in obese patients, suggesting that high-dose prophylactic anticoagulation was effective in preventing TCs in this high-risk population.

We also found that 7% of patients experienced bleeding complications. Most complications were minor, although four patients experienced intracranial hemorrhage and one patient died of hemorrhage. These results are consistent with another French study in which only 2.7% of patients experienced bleeding complications, whereas 30% of patients were receiving therapeutic anticoagulation.<sup>5</sup> Paranjpe et al<sup>14</sup> also did not observe increased risk of bleeding by increasing the dose of prophylactic anticoagulation in patients hospitalized for COVID-19. Similarly, we reported no association between cumulative exposure to higher prophylactic anticoagulation and a bleeding complication. However, the anticoagulant status was unknown in 38.5% of patients because the date of the bleeding event was unavailable, and statistical analysis may be underpowered.

Contrary to recently published studies,<sup>18,19</sup> the mortality rate was not influenced by high-dose prophylactic anticoagulation in our study. We recorded the mortality rate only on day 14, which in our study was 11.9%, whereas the ICU mortality rate described in these studies ranged from 29.6% to 48.3%. In addition, unlike these studies that included only therapeutic anticoagulation, we also included intermediate-dose anticoagulation in our analysis, which may not have been sufficient to influence mortality.

Our study has several limitations. First, data collection was limited to the first 14 days. The follow-up period was limited to minimize the contribution of long-term unspecific ICU complications. Indeed, according to the pathophysiologic features of COVID-19-induced thrombosis, hypercoagulability is high within this early period and then decreases, and thrombotic events were reported at a median of 6 days (IQR, 1-13 days) after admission to the ICU.<sup>20</sup> Nevertheless, because bleeding events seem to occur later, at a median of 15 days (IQR, 6-25 days) after ICU admission,<sup>21</sup> we might have underestimated the incidence of bleeding events. Second, because of the retrospective design of the study, some data were missing, especially those of patients who were

transferred to other ICUs as part of the reorganization of the national health care system during the pandemic. The anticoagulation strategy was not standardized among centers, and none of the ICUs used a systematic VTE screening policy. However, data were sufficiently robust to classify the anticoagulation status of most patients.

In conclusion, we showed that high-dose prophylactic anticoagulation therapy is associated with reduced TCs in critically ill patients with COVID-19, without increasing the risk of bleeding. Randomized controlled trials comparing prophylactic and higher doses of anticoagulants are needed to confirm these results further.

## Acknowledgments

**Author contributions:** C. T. is the guarantor of the content of the manuscript, including the data and analysis. C. T., A. M., and A. Gondon contributed substantially to the conception and design of the study, to the acquisition of data, and to the analysis and interpretation of the data; drafted the article; and provided final approval of the version submitted for publication. J. G. and J. H. L. contributed substantially to the analysis and interpretation of the data, provided critical revision of the article, and provided final approval of the version submitted for publication. J. P., D. G., E. K., S. R. H., P. M. M., A. S., M. U.-R., B. B., M. N., F. R., I. G.-T., M. C. B., N. C., and S. M. contributed substantially to the acquisition of data, provided critical revision of the article, and provided final approval of the version submitted for publication. Y. G., P. A., S. S., and A. Gondier contributed substantially to the acquisition of data and to the analysis and interpretation of the data, provided critical revision of the article, and provided final approval of the version submitted for publication.

**Financial/nonfinancial disclosures:** The authors have reported to *CHEST* the following: A. Gondier has received honoraria and travel fees from Bayer-Healthcare, Boehringer-Ingelheim, Bristol-Myers-Squibb/Pfizer, and Sanofi. Y. G. has received honoraria and travel fees from Aguettant, Bayer-Healthcare, Bristol-Myers-Squibb/Pfizer, CSL Behring, Octapharma, Roche, Sanofi, and Sobi. J. H. L. is a member of the safety monitoring committees and advisory boards for Instrumentation Labs, Leading Biosciences, Merck, and Octapharma. S. S. has received research support and travel fees from Biomarin, Bristol-Myers-Squibb/Pfizer, CorWave, Carmat, CSL Behring, LFB, Roche, Sanofi, Sobi, and Takeda (fees go to Lille University Hospital). S. R. H. is a lecturer for and has received grants from LFB and

Octapharma. P. A. has received honoraria and travel fees from Bayer-Healthcare, Bristol-Myers-Squibb/Pfizer, Sanofi, Aspen, Aguettant, and Portola. None declared (C. T., A. M., A. Gondon, J. G., J. P., D. G., E. K., P. M. M., A. S., M. U. R., B. B., M. N., F. R., I. G. T., M. C. B., N. C., S. M.

**Role of sponsors:** The sponsor had no role in the design of the study, the collection and analysis of the data, or the preparation of the manuscript.

**\*French Working Group on Perioperative Hemostasis Collaborators:** P. Albaladejo (Anesthesia and Critical Care, Grenoble France), N. Blais (Hematology-Hemostasis, Montréal, Canada), F. Bonhomme (Anesthesia and Critical Care, Geneva, Switzerland), A. Borel-Derlon (Hematology-Hemostasis, Caen, France), A. Cohen (Cardiology, Paris, France), J.-P. Collet (Cardiology, Paris, France), E. de Maistre (Hematology-Hemostasis, Dijon, France), P. Fontana (Hematology-Hemostasis, Geneva, Switzerland), D. Garrigue Huet (Anesthesia and Critical Care, Lille, France), A. Godier (Anesthesia and Critical Care, Paris, France), Y. Gruel (Hematology-Hemostasis, Tours, France), A. Godon (Anesthesia and Critical Care, Grenoble, France), B. Ickx (Anesthesia and Critical Care, Brussels, Belgium), S. Laporte (Clinical Pharmacology, Saint-Etienne, France), D. Lasne (Hematology-Hemostasis, Paris, France), J. Llau (Anesthesia and Critical Care, Valencia, Spain), G. Le Gal (Vascular Medicine, Ottawa, Canada), T. Lecompte (Hematology-Hemostasis, Geneva, Switzerland), S. Lessire (Anesthesia and Critical Care, Namur, Belgium), J.H. Levy (Anesthesia and Critical Care, Durham, USA), D. Longrois (Anesthesia and Critical Care, Paris, France), S. Madi-Jebara (Anesthesia and Critical Care, Beyrouth, Lebanon), A. Mansour (Anesthesia and Critical Care, Rennes, France), M. Mazighi (Neurology, Paris, France), P. Mismetti (Clinical Pharmacology, Saint-Etienne), P.E.

Morange (Hematology-Hemostasis, Marseille, France), S. Motte (Vascular Medicine, Brussels, Belgium), F. Mullier (Hematology-Hemostasis, Namur, Belgium), N. Nathan (Anesthesia and Critical Care, Limoges, France), P. Nguyen (Hematology-Hemostasis, Reims, France), G. Per-nod (Vascular Medicine, Grenoble, France), N. Rosencher (Anesthesia and Critical Care, Paris, France), S. Roulet (Anesthesia and Critical Care, Bordeaux, France), P.M. Roy (Emergency Medicine, Angers, France), S. Schlumberger (Anesthesia and Critical Care, Suresnes, France), P. Sié (Hematology-Hemostasis, Toulouse, France), A. Steib (Anesthesia and Critical Care, Strasbourg, France), S. Susen (Hematology-Hemostasis, Lille, France), C.A. Tacquard (Anesthesia and Critical Care, Strasbourg, France), S. Testa (Hematology, Cremona, Italy), A. Vincentelli (Cardiac Surgery, Lille, France), and P. Zufferey (Anesthesia and Critical Care, Saint-Etienne, France).

**Other contributions:** C. T. thanks L. Ryffel and M. Kieffer for their assistance in data acquisition in Strasbourg.

**Additional information:** The e-Figures and e-Tables can be found in the [Supplemental Materials](#) section of the online article.

## References

1. Al-Ani F, Chehade S, Lazo-Langner A. Thrombosis risk associated with COVID-19 infection. A scoping review. *Thromb Res.* 2020;192:152-160.
2. Klok FA, Kruip MJHA, van der Meer NJM, et al. Incidence of thrombotic complications in critically ill ICU patients with COVID-19. *Thromb Res.* 2020;191:145-147.
3. Cui S, Chen S, Li X, Liu S, Wang F. Prevalence of venous thromboembolism in patients with severe novel coronavirus pneumonia. *J Thromb Haemost.* 2020;18(6):1421-1424.

4. Middeldorp S, Coppens M, Haaps TF van, et al. Incidence of venous thromboembolism in hospitalized patients with COVID-19. *J Thromb Haemost.* 2020;18:1995-2002.
5. Helms J, Tacquard C, Severac F, et al. High risk of thrombosis in patients in severe SARS-CoV-2 infection: a multicenter prospective cohort study. *Intensive Care Med.* 2020;46(6):1089-1098.
6. Rosovsky RP, Sanfilippo KM, Wang TF, et al. Anticoagulation practice patterns in COVID-19: a global survey. *Res Pract Thromb Haemost.* 2020;4(6):969-983.
7. Susen S, Tacquard CA, Godon A, et al. Prevention of thrombotic risk in hospitalized patients with COVID-19 and hemostasis monitoring. *Crit Care.* 2020;24(1):364.
8. Poissy J, Goutay J, Caplan M, et al. Pulmonary embolism in COVID-19 patients: awareness of an increased prevalence. *Circulation.* 2020;142:184-186.
9. Rocca B, Fox KAA, Ajjan RA, et al. Antithrombotic therapy and body mass: an expert position paper of the ESC Working Group on Thrombosis. *Eur Heart J.* 2018;39(19):1672-1686f.
10. Schulman S, Kearon C; Subcommittee on Control of Anticoagulation of the Scientific and Standardization Committee of the International Society on Thrombosis and Haemostasis. Definition of major bleeding in clinical investigations of antihemostatic medicinal products in non-surgical patients. *J Thromb Haemost.* 2005;3(4):692-694.
11. Grafféo N, Castell F, Belot A, Giorgi R. A log-rank-type test to compare net survival distributions: a test to compare net survival distributions. *Biometrics.* 2016;72(3):760-769.
12. van der Wal WM, Geskus RB. Ipw: an R package for inverse probability weighting. *J Stat Soft.* 2011;43(13):1-23.
13. Bilaloglu S, Aphinyanaphongs Y, Jones S, Iturrate E, Hochman J, Berger JS. Thrombosis in hospitalized patients with COVID-19 in a New York City health system. *JAMA.* 2020;324(8):799.
14. Paranjpe I, Fuster V, Lala A, et al. Association of treatment dose anticoagulation with in-hospital survival among hospitalized patients with COVID-19. *J Am Coll Cardiol.* 2020;76(1):122-124.
15. Paolisso P, Bergamaschi L, D'Angelo EC, et al. Preliminary experience with low molecular weight heparin strategy in COVID-19 patients. *Front Pharmacol.* 2020;11:1124.
16. Zhang L, Feng X, Zhang D, et al. Deep vein thrombosis in hospitalized patients with COVID-19 in Wuhan, China: prevalence, risk factors, and outcome. *Circulation.* 2020;142(2):114-128.
17. Seidu S, Gillies C, Zaccardi F, et al. The impact of obesity on severe disease and mortality in people with SARS-CoV-2: a systematic review and meta-analysis. *Endocrinol Diab Metab.* In press.
18. Hsu A, Liu Y, Zayac AS, Olszewski AJ, Reagan JL. Intensity of anticoagulation and survival in patients hospitalized with COVID-19 pneumonia. *Thromb Res.* 2020;196:375-378.
19. Ionescu F, Jaiyesimi I, Petrescu I, et al. Association of anticoagulation dose and survival in hospitalized COVID-19 patients: a retrospective propensity score-weighted analysis. *Eur J Haematol.* 2021;106(2):165-174.
20. Atallah B, Sadik ZG, Salem N, et al. The impact of protocol-based high-intensity pharmacological thromboprophylaxis on thrombotic events in critically ill COVID-19 patients. *Anaesthesia.* 2021;76:327-335.
21. Shah A, Donovan K, McHugh A, et al. Thrombotic and haemorrhagic complications in critically ill patients with COVID-19: a multicentre observational study. *Crit Care.* 2020;24(1):561.