

# Machine-Assisted Organic Synthesis

*Steven V. Ley,\* Daniel E. Fitzpatrick, Rebecca M. Myers, Claudio Battilocchio,  
and Richard J. Ingham*

**Keywords:**

machine-assisted synthesis ·  
sustainable chemistry ·  
synthetic methods

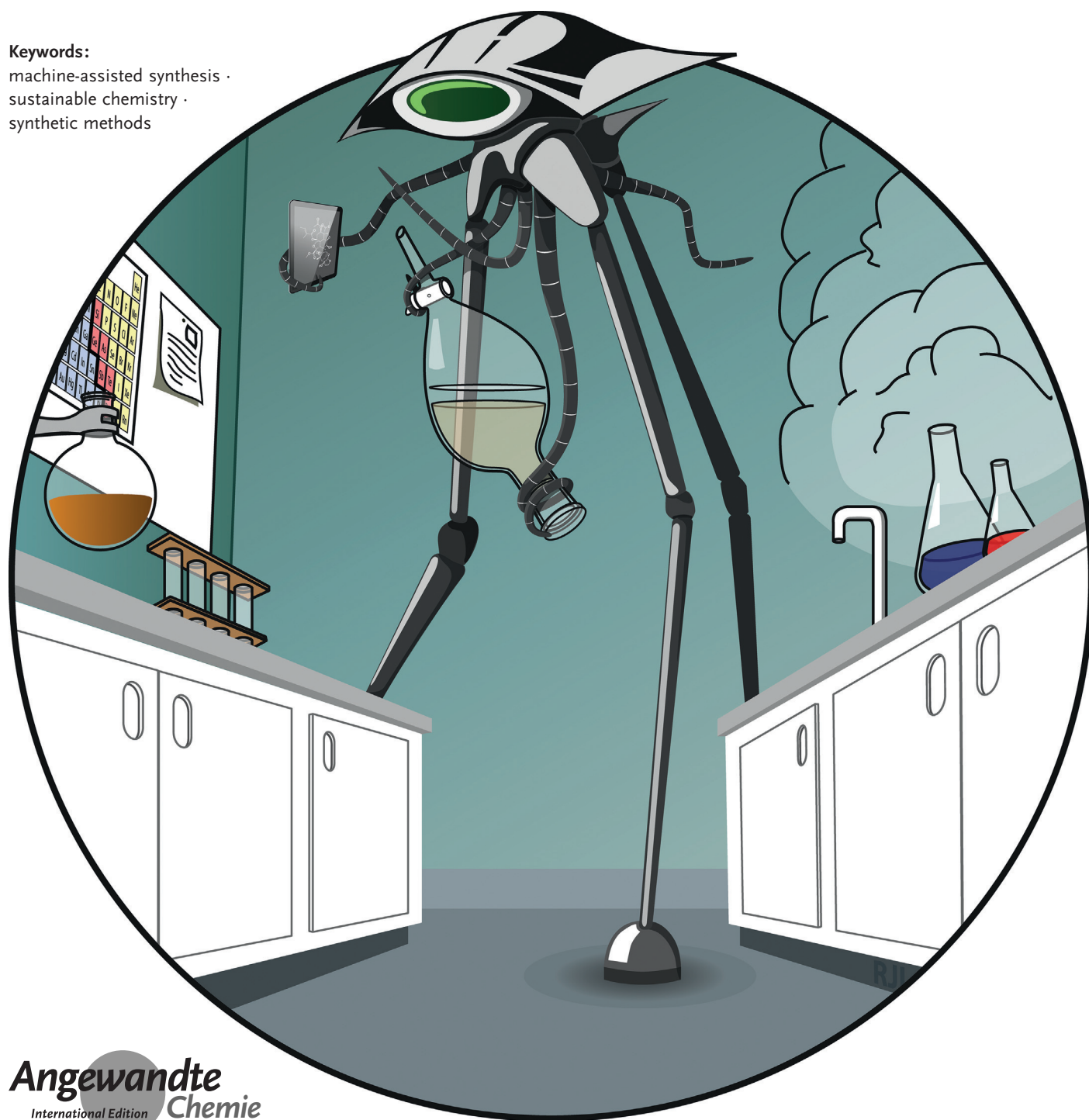

*In this Review we describe how the advent of machines is impacting on organic synthesis programs, with particular emphasis on the practical issues associated with the design of chemical reactors. In the rapidly changing, multivariant environment of the research laboratory, equipment needs to be modular to accommodate high and low temperatures and pressures, enzymes, multiphase systems, slurries, gases, and organometallic compounds. Additional technologies have been developed to facilitate more specialized reaction techniques such as electrochemical and photochemical methods. All of these areas create both opportunities and challenges during adoption as enabling technologies.*

## 1. Introduction

In our first Review on this theme,<sup>[1]</sup> we endeavored to make the case why synthesis laboratories of today need to change by adopting a machine-assisted approach to more efficiently use human resources. By recognizing synthesis as a holistic system and by integrating chemistry with engineering and informatics, greater safety and enhanced efficiencies arise while also opening up new pathways to discovery. Our modern world is evolving rapidly. The “internet of things” (IoT) is with us today, which provides previously undreamt opportunities in consumer services through the advanced connectivity of equipment and devices linked through the internet.<sup>[2]</sup> Communication between machines and neural networking will be a component of any future laboratory. The acquisition and the mining of “big data” along with technology developments, such as cheap microprocessing devices<sup>[3]</sup> and material-handling robots, are poised to revolutionize how we will design and optimize chemical processes.

More than ever, the skills of the synthetic chemist are in demand over an ever-increasing range of sciences. Correspondingly, the skill set will vary from routine, repetitive, and scale-up tasks to highly advanced multistep syntheses of complex architectures. All of this activity will only advance if new strategically important reactions and new enabling technologies are discovered.<sup>[4]</sup> It is still, and will remain, a labor-intensive practice that relies heavily on training, planning, experience, observation, and interpretation. At one level it is a craft but, at its highest, it is a true form of art that creates functional molecules previously not known on this planet.

Machines can only assist in this process and are never fully able to mimic or automate the abilities of an innovative bench chemist, but they help by generating more time to think and design new processes. The first review “Organic Synthesis: March of the Machines”<sup>[1]</sup> concentrated largely on the use of machinery to address issues encountered in downstream chemical processing in the research environment, including the handling of materials and analytical methods. In this new Review we focus more on up-stream events that occur at the time of reaction in terms of problem solving and managing the components associated with complex synthesis programs. We describe our views on problems that have been overcome by

## From the Contents

<b>1. Introduction</b>	10123
<b>2. Supercritical Fluid Systems</b>	10124
<b>3. Handling Gases</b>	10125
<b>4. Extreme Temperatures</b>	10128
<b>5. Enzymes</b>	10130
<b>6. Managing Slurries</b>	10131
<b>7. Managing Organometallic Compounds</b>	10132
<b>8. Electrocatalytic Reactors</b>	10133
<b>9. Photocatalytic Reactors</b>	10134
<b>10. Summary and Outlook</b>	10135

using a machine-assisted approach, based both on recent literature and our own reported work.

Previous articles of this type tend to emphasize outputs, while here we concentrate more on the practical issues, especially those encountered during the development of flow reactors and of continuous processing technologies and their related equipment (Figure 1). We specifically highlight the

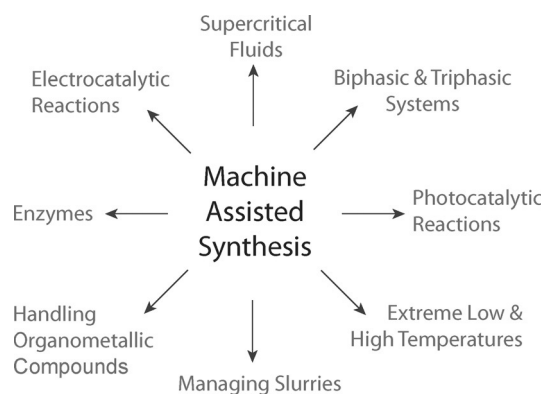

**Figure 1.** The topic of machine-assisted organic synthesis has been divided into eight sections in this Review.

[\*] Prof. S. V. Ley, Dr. E. Fitzpatrick, Dr. R. M. Myers, Dr. C. Battilocchio, Dr. R. J. Ingham  
Department of Chemistry, University of Cambridge  
Lensfield Road, Cambridge, CB2 1EW (UK)  
E-mail: svl1000@cam.ac.uk

© 2015 The Authors. Published by Wiley-VCH Verlag GmbH & Co. KGaA. This is an open access article under the terms of the Creative Commons Attribution License, which permits use, distribution and reproduction in any medium, provided the original work is properly cited.

special machine requirements imposed by handling supercritical fluids and the safe use of other reactive gases. Also of concern is the ability to have equipment that can operate over extremes of temperature and pressure. Increasingly too, the use of enzymes in reactor systems is becoming more general to expand the repertoire of synthetic chemists. Issues relating to slurries, organometallic compounds, and other hazardous or air-sensitive materials require machine development, although more and more devices are coming onto the market. We are also seeing a resurgence of interest in electro- and photochemical processing methods, which lead in turn to innovation in reactor design. Each of these areas presents its own challenges and problems which, as described herein, have been solved through the use of pioneering machinery.

## 2. Supercritical Fluid Systems

When a solvent such as CO<sub>2</sub> is placed under conditions exceeding its critical point, it enters the supercritical state and

its properties change in such a way that it cannot be classified as just a liquid or just a gas. The density and viscosity of this fluid are strongly dependent on the temperature and pressure, and so a small change in conditions can strongly influence reaction conditions, such as reagent solubility. This behavior provides a unique opportunity for researchers to conduct experiments in a highly tunable and chemically different environment.

By its very nature, reactions carried out in a supercritical fluid medium require the extensive use of machinery to maintain the conditions necessary for the system to remain in the supercritical state. This machinery is able to support a vast range of well-known reactions, such as Suzuki–Miyaura coupling,<sup>[5]</sup> hydrogenation,<sup>[6]</sup> and esterification,<sup>[7]</sup> in addition to those involving unusual solvents such as 1,1,1,2-tetrafluoroethane.<sup>[8]</sup> In most cases the solvent used for supercritical reactions is carbon dioxide or water, a fact that has given supercritical systems a reputation as being more environmentally friendly than traditional reaction procedures.<sup>[9]</sup> Indeed, a recent study reported the use of a catalytic reaction in supercritical CO<sub>2</sub> for the hydrodechlorination of chlorodifluoromethane, an ozone-depleting compound, to achieve the highest ever reported yield and selectivity for its conversion into difluoromethane, an ozone-inert substance.<sup>[10]</sup> However, regular servicing of equipment is necessary because of the corrosive nature of the system when operating under supercritical conditions with CO<sub>2</sub>.

As there are a number of reviews focusing on specialist machinery<sup>[11]</sup> and techniques<sup>[12]</sup> that support supercritical reaction systems, we have limited our discussion here to studies that we particularly wish to highlight.



Professor Steven Ley has been a Professor of Chemistry at the University of Cambridge since 1992. He obtained his PhD from Loughborough University with Professor Harry Heaney and carried out postdoctoral research with Professor Leo Paquette (Ohio State) and then with Professor Derek Barton (Imperial College). He was appointed as a lecturer at Imperial College in 1975, promoted to Professor in 1983, and then to Head of Department in 1989. In 1990 he was elected to the Royal Society (London) and was President of The Royal Society of Chemistry 2000–2002. He has published over 800 papers and has gained 50 major awards.



Daniel Fitzpatrick completed a BE (Hons) in Chemical and Materials Engineering at the University of Auckland in 2012. In the same year he was awarded a Woolf Fisher Scholarship enabling him to begin PhD studies at the University of Cambridge in October 2013 under the supervision of Professor Steven Ley. His research is focused on bridging chemistry with chemical engineering, with attention given to advanced control systems and separation techniques.



Rebecca Myers studied Chemistry at Imperial College (1994–97). She followed this with a PhD in Organic Chemistry at the University of Cambridge under the supervision of Professor Chris Abell (1997–01). She joined the Ley group as a postdoctoral researcher in 2004 and was promoted to Senior Research Associate in 2010. She is also Associate Director of the Cambridge PhD Training Program in Chemical Biology and Molecular Medicine.

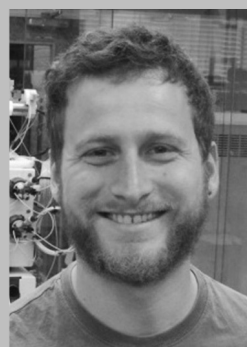

Claudio Battilocchio completed his undergraduate studies in Medicinal Chemistry at Sapienza, University of Rome in 2008. He started his PhD in Pharmaceutical Sciences with Professor Mariangela Biava, researching the development of new molecular hybrids. In 2011 he was a visiting PhD student in the Innovative Technology Centre (ITC) at the University of Cambridge, working on the development of sustainable processes using flow chemistry. He rejoined the Ley group in 2012, and is currently a postdoctoral research associate working on the collaborative Open Innovation Programme with Pfizer.



Richard Ingham completed his undergraduate degree in Natural Sciences at the University of Cambridge, working on natural product synthesis for his Master's project. He then spent six months working on flow synthesis at Cyclofluidic Ltd, before returning to Cambridge in 2010 to work under Professor Steven Ley in the Innovative Technology Centre (ITC). His PhD research focuses on the integration of software and technologies for performing multistep synthesis under flow conditions.

The supercritical studies conducted by the research group of Poliakoff in Nottingham are well known, having received a large number of citations since their publication. In these, the group makes extensive references to the use of enabling tools and methods to enhance the productivity of researchers in areas such as the automated optimization of reactions (as described in our previous review<sup>[1]</sup>).

In one recent study, bespoke devices were used to conduct a continuous photo-oxidation reaction for one of three steps in the synthesis of antimalarial trioxanes.<sup>[13]</sup> An allylic alcohol was pumped with 5,10,15,20-tetrakis(pentafluorophenyl)porphyrin (TPFPF) and a cyclic ketone (a cosolvent to solubilize the TPFPF and reagent in the next step) into a stream of CO<sub>2</sub>

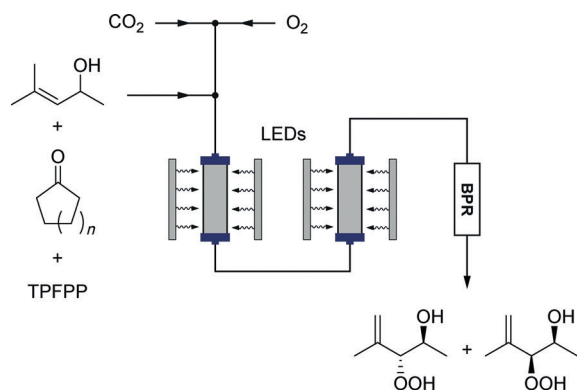

**Figure 2.** Continuous photo-oxidation under supercritical CO<sub>2</sub> conditions for the production of antimalarial trioxanes. A series of UV LEDs and sapphire reactors were used to expose the reagents to UV radiation.

and O<sub>2</sub> before passing through two sapphire tube reactors in which the contents were irradiated with UV LEDs (Figure 2). A yield of 86 % of the product hydroperoxides was reported (an improvement over the batch process) with a *syn* selectivity of 85 %.

In another study, the same group demonstrated a multi-column reactor concept which enabled researchers to switch products formed in real-time by changing the column conditions.<sup>[14]</sup> Two packed reactor columns were placed in series, one containing copper chromate and the other Pd/C, each with its own H<sub>2</sub> supply. A feed stream containing furfural (Figure 3a) was mixed with CO<sub>2</sub> before entering the first column. It was found that a range of products could be formed (Figure 3b) in relatively high yields (> 80 %) by adjusting the column temperatures and the amount of H<sub>2</sub> supplied to each column in turn.

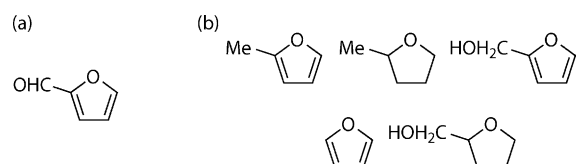

**Figure 3.** a) Furfural was used as a feed material, alongside H<sub>2</sub>, in the twin-column system. b) Hydrogenation products of furfural under supercritical conditions.

They have also demonstrated the use of supercritical-supporting apparatus to conduct reactions under extreme conditions.<sup>[15]</sup> During the synthesis of  $\epsilon$ -caprolactam from 6-aminocapronitrile, reactor conditions were held at a temperature of 400 °C and pressure of 400 bar. The conversion reported under these conditions (ca. 94 %) represented a significant improvement on the conversion from the traditional, cyclohexanone-based synthesis route (3–6 %).

In another study, a supercritical fluid reaction platform was developed that incorporated precise control of the conditions and automation through the use of a computerized system in addition to a supercritical fluid chromatography unit for online analysis.<sup>[16]</sup> Through the inclusion of this machine-assisted approach, the investigators were able to gain valuable knowledge about the experimental system by varying the conditions without a large time burden on the researchers. The platform was shown to be suitable for both laboratory and pilot plant scale operations.

It is important to recognize that various pressure-release and step-down devices are necessary for larger-scale preparative studies. Furthermore, compound dispersion can be an issue. Economic benefits can be obtained when recovering and recycling CO<sub>2</sub> from the back-end of reaction systems, especially when dealing with larger-scale processes.

### 3. Handling Gases

When using reactive gases during reaction procedures, specialized equipment is needed to handle variations in pressure and flow regimes characteristic of multiphase systems. Commonly encountered reactions in a research laboratory can be divided into two main categories: biphasic (gas–liquid or gas–solid) and triphasic (gas–liquid–solid systems). Accordingly, we have grouped our discussion on this topic to new developments in these areas.

#### 3.1. Biphasic Systems

Traditionally, gas–liquid mixing is achieved by using direct injection techniques, where gas is pumped or sparged into a solution stream, thereby resulting in bubbling in the case of batch reactions or an alternating biphasic stream in the case of flow reactions. More modern approaches focus on the use of membranes to dissolve a gas in a liquid phase to effect reagent mixing. A review has described such an approach as applied to microreactors.<sup>[17]</sup>

In 2010, our group developed a novel reactor design which facilitated gas–liquid contact in pressurized systems through the use of a semipermeable membrane made from teflon AF-2400.<sup>[18]</sup> Early designs were based on the membrane being placed into a pressurized reaction chamber in which a large volume of gas was present. Having such a large dead-volume of reactive gas present is undesirable when carrying out reactions using hazardous gases such as ozone. As such, the reactor configuration was modified to resemble a tube-in-tube system, where membrane piping was placed inside tubing material of a larger diameter. In this case, solution was

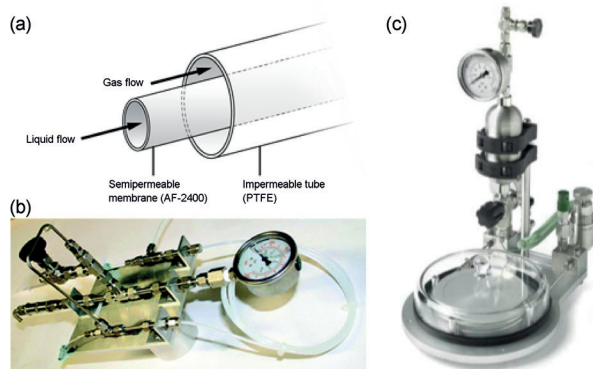

**Figure 4.** a) Annular, tube-in-tube fluid-flow regions. The semipermeable membrane tubing is placed inside an impermeable PTFE outer layer. b) Prototype reactor used to facilitate gas–liquid reactions.<sup>[27]</sup> Reproduced with permission from The Royal Society of Chemistry. c) The Gastropod reactor from Cambridge Reactor Design, a commercially available unit that was developed from this study.<sup>[29]</sup>

pumped through the center of the inner pipe while pressurized gas was pumped through the annular region between the membrane and outer tubing or vice versa (Figure 4). By doing so, the volume of gas within the reactor is greatly minimized, thereby mitigating any safety risks.

We have since reported the use of this system for Heck cross-coupling reactions for the synthesis of styrene<sup>[19]</sup> ( $C_2H_4$ ), Paal–Knorr pyrrole formation<sup>[20]</sup> ( $NH_3$ ), synthesis of thioureas<sup>[21]</sup> and fanetizole<sup>[22]</sup> ( $NH_3$ ), syngas-mediated hydroformylation of styrenes<sup>[23]</sup> ( $CO$  and  $H_2$ ), as well as routine carboxylations<sup>[24]</sup> ( $CO_2$ ), hydrogenations<sup>[25]</sup> ( $H_2$ ), and Glaser coupling reactions<sup>[26]</sup> ( $O_2$ ). Furthermore, through the combination of inline FTIR measurement for the measurement of  $CO$  concentration in situ in one study<sup>[27]</sup> and the use of solid-supported reagents in another,<sup>[28]</sup> we showed how it was possible to greatly enhance a working regime by employing a machine-assisted approach for carbonylations. By linking these devices, we were easily able to run degassing procedures or multigas combinations, thereby creating new potential synthesis opportunities.

Other research groups have used similar tube-in-tube systems for the development of various reactions, including one by Mercadante and Leadbeater, in which a palladium-catalyzed alkoxycarbonylation reaction was performed.<sup>[30]</sup> A gas-permeable membrane tube was placed inside stainless-steel tubing to provide improved thermal-transfer properties, increased rigidity, and the ability to measure the temperature of the liquid stream by means of a thermocouple in direct contact with the membrane tube.  $CO$  was pumped through the center of the membrane tube while a solution containing ethanol or propanol, an aryl iodide, diazabicycloundecene (DBU), and palladium(II) acetate ( $Pd(OAc)_2$ ) was pumped in a countercurrent manner through the annular region between the membrane and steel tube. By using this system it was possible to achieve 91–99% conversions of the iodide into its corresponding ester at  $120^\circ C$  when using 0.5 mol%  $Pd(OAc)_2$ . The researchers commented that their use of a membrane system saved significant time and minimized

the volumes of  $CO$  required, thus decreasing poisoning of the catalyst and improving reaction safety.

More recently, a membrane tube-in-tube system was utilized to explore the use of inline FTIR analysis and a gas-flow meter to monitor gas consumption in a microfluidic reactor,<sup>[31]</sup> similar to our previously described study. It was reported that these tools provided the ability to accurately control the rate of gas feed into the reactor and thus the stoichiometry within the solution stream.

The use of gas-permeable membranes has greatly increased safety when dealing with hazardous reagents, such as diazomethane. Through the in situ generation, transportation, and reaction of diazomethane ( $CH_2N_2$ ) in a membrane-

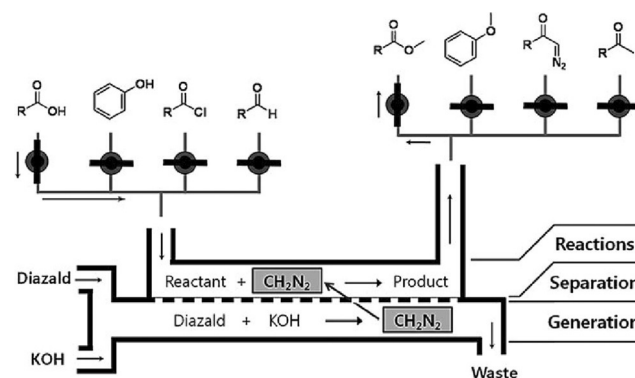

**Figure 5.** The various reactions carried out by Kim and co-workers using a membrane microreactor to facilitate the generation and subsequent consumption of diazomethane.<sup>[32]</sup>

based microreactor system (Figure 5), researchers were able to conduct a variety of methylation reactions without the need to maintain any quantity of  $CH_2N_2$ .<sup>[32]</sup> A similar membrane system has also been reported by this group when carrying out catalytic Heck reactions with  $O_2$ .<sup>[33]</sup>

In summary, the reactions mentioned above focused on gas–liquid interactions. We now highlight two recent studies involving gas–solid systems; we will exclude the last permutation of biphasic systems (liquid–solid interactions), as we have described a number of systems that operate under these conditions elsewhere in this Review.

The use of a fluidized-bed reactor for the photocatalytic formation of styrene from ethylbenzene over sulfated  $MoO_x/\gamma-Al_2O_3$  has been reported.<sup>[34]</sup> Ethylbenzene and water vapor were fed into a gaseous stream containing  $O_2$  and  $N_2$  by means of two temperature-controlled saturators. This mixture was then pumped into a heated reaction chamber, in which solid particles of catalyst and silica were placed under illumination by UVA LED modules (Figure 6). The upwards gas movement in the reaction chamber served to fluidize the particle bed, thus causing turbulent flow and promoting excellent mixing between the gas and solid phases. This system configuration improved on the selectivity of the catalytic process, achieving 100% selectivity under less harsh conditions than those reported previously.

Another study investigated the important effects of reactor configuration on fluidized-bed performance for the

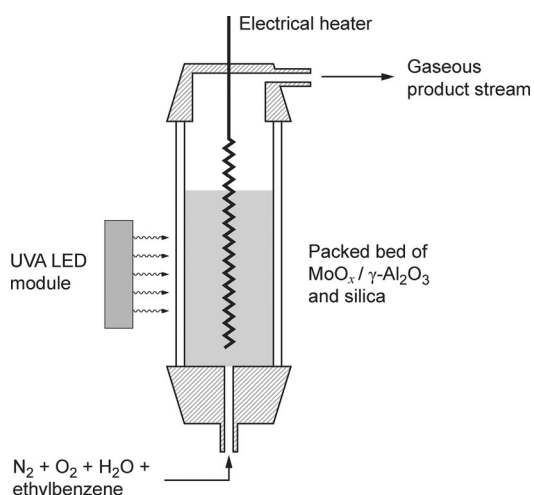

**Figure 6.** A photocatalytic reactor in which a gas stream was used to fluidize catalyst particles to form styrene from ethylbenzene.

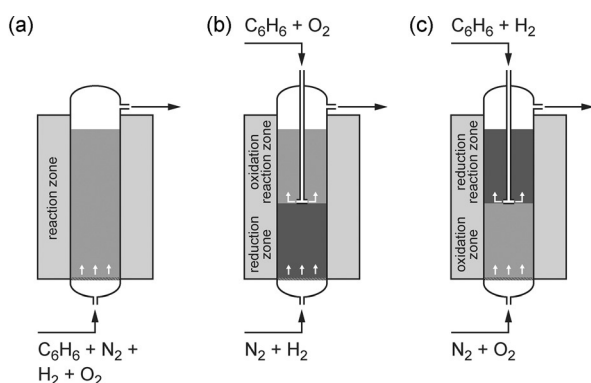

**Figure 7.** The performance of various equipment layouts was compared for a fluidized bed system. a) All gases were fed together into the reactor through one injection point. b) A two-zone injection system with gaseous nitrogen and hydrogen streams fed from the base and benzene and oxygen fed from the top. c) A similar two-zone injection system, but hydrogen and oxygen inputs were switched.

production of phenol from the oxidation of benzene.<sup>[35]</sup> Three beds were tested: the first was a single-zone, conventional fluidized-bed reactor in which all the reactants were fed into the system simultaneously (Figure 7a); the second was a two-zone bed where  $N_2$  and  $H_2$  were fed into the base while benzene and  $O_2$  were fed in from the center (Figure 7b); and the third was also a two-zone bed, but the injection point of  $O_2$  and  $H_2$  were switched (Figure 7c). The solid catalyst used in all cases was  $Pt-VO_x/SiO_2$ . By adjusting the position of the gas injection in the two-bed systems and thus the reaction selectivity, it was found that it was possible to form mixtures of phenol and cyclohexanone or cyclohexane of various compositions simply through the addition point. It was found that 100% selectivity for the production of phenol could be obtained when the oxygen was injected at half-bed height (Figure 7b). It would not have been possible to evaluate all these dynamic parameters in static batch-reactor systems.

### 3.2. Triphasic Systems

In most triphasic systems, certainly those that occur in an organic synthesis context, chemical transformations occur at the interface between the gas and the liquid while the solid acts in a catalytic capacity. Accordingly, the solid component is immobilized (such as in a packed column) while the gas and liquid flow around the particles. In some cases, usually where catalyst deactivation is observed, the solid phase is not immobilized but is recycled back through the reaction system, having passed through a regeneration loop; however, this style of continuous process is rarely found in a research laboratory environment and so will not be discussed here.

One of the most common processes operating under triphasic conditions on a laboratory research scale is contin-



**Figure 8.** The HEL FlowCAT trickle-flow reactor has been used for the hydrogenation of ethyl nicotinate over a packed-bed catalyst.

uous hydrogenation. As this area has been previously described,<sup>[36]</sup> here we will only highlight one of our own recent reports using the commercially available HEL FlowCAT fixed-bed, trickle-flow reactor (Figure 8).<sup>[37]</sup> In this study, ethyl nicotinate was fully hydrogenated over a packed catalyst bed consisting of either  $Pd/Al_2O_3$  or  $Rh/Al_2O_3$ . The best results were obtained when a 2.0M solution of ethyl nicotinate in ethyl acetate was pumped over 4 g of the rhodium-containing catalyst with  $0.6 \text{ mL min}^{-1} H_2$  (100 bar) at a temperature of  $160^\circ\text{C}$ . Under these conditions it was possible to process 530 g of starting material in 6.5 h (equivalent to ca.  $2 \text{ kg day}^{-1}$ ). It is clear that such bench-top apparatus opens a world of opportunities in terms of scalability that would otherwise not be possible when used in a standard laboratory environment.

## 4. Extreme Temperatures

### 4.1. Low Temperatures

Handling reactions at the extremes of the temperature spectrum presents its own challenges. To achieve the cryogenic conditions required for batch chemistry, such as reactions that involve organometallic intermediates, it is common to submerge portions of glassware in solvents, such as acetone, which have been mixed with dry ice. This technique requires consumables in the form of solid CO<sub>2</sub> and poses some safety risk from spills. For longer reactions, consumables need to be replaced at regular intervals to ensure that the required cold reaction conditions are maintained. This task can be both a distraction and considerable inconvenience, especially if multiple reactions need to be conducted over a full working day. Although cryo-cooling devices for batch reactions are available, these are limited to smaller scales.

We too have controlled reactions at low temperatures by submerging reactor coils in cooling baths, but to seriously tackle the challenges of conducting cryogenic reactions on larger scales in a continuous fashion, without the interruptions of replacing consumables, new machinery had to be developed.

The solution to this came in the form of an electrical refrigeration device, in which the temperature of a metal pipe in contact with a cooling plate is reduced to the desired set point.<sup>[38]</sup> A metal coiled-tube reactor is placed around this pipe, while a removable double-walled glass dome serves to minimize heat transfer from the surrounding laboratory environment to the reactor coil. This machine, named the “Polar Bear”, was used for both the segmented and continuous synthesis of a variety of boronic esters using *n*-butyllithium, an aryl halide, and a boron electrophile (PinBOiPr). The system can maintain temperatures as low as –89 °C for indefinite periods, while the design of the outer casing was shown to prevent noticeable frosting on the flow coils. More recently, we have used this device with a Vapourtec R2 unit for a two-part diastereoselective fluorination process<sup>[39]</sup> and have proposed a low-temperature modular-flow platform on which a variety of reactions were demonstrated.<sup>[40]</sup>

Further developments to the “Polar Bear” yielded a second-generation device (the “Polar Bear Plus”, Figure 9) with which it was possible to accurately maintain conditions over a wider range of temperatures: from –40 °C to +150 °C.<sup>[41]</sup> By using miniaturized compressors it was possible to reduce the size of this device by over 89% and its weight from 65 kg to 12 kg. The modular nature of the heating and cooling plate in this system enables the unit to be used for batch and flow reactions, as well as continuous stirred tank reactor (CSTR) systems. Our group has used this device for the preparation of thiourea using a tube-in-tube gas coil configuration with ammonia and for the continuous telescoped flow synthesis of fanetizole.<sup>[22]</sup>

The use of a multijet oscillating disk reactor system (MJOD), as described in more detail in Section 6, has also been demonstrated under cryogenic conditions. A research

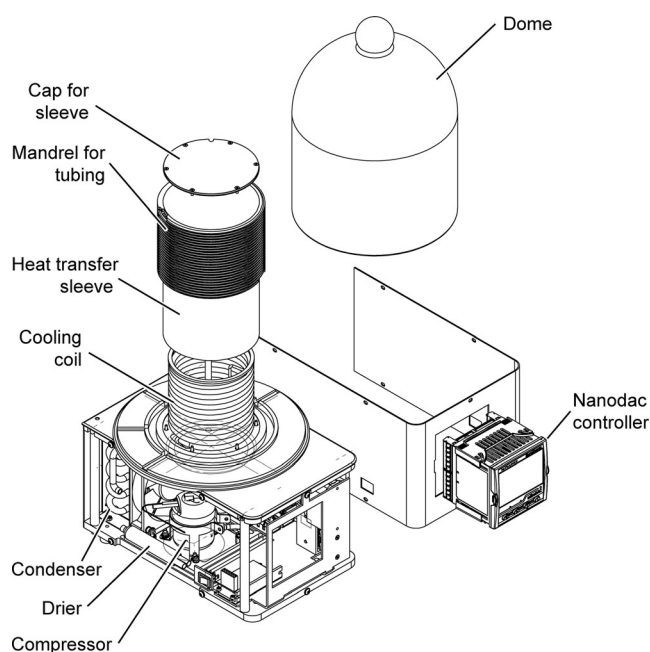

**Figure 9.** Expanded view of the Polar Bear Plus from Cambridge Reactor Design showing the refrigeration loops and other key components.<sup>[29]</sup>

team prepared phenylboronic acids at temperatures between –50 °C and –75 °C in a telescoped flow synthesis procedure; ethanol was pumped through heat exchangers and a reactor jacket as a cooling agent.<sup>[42]</sup> This system demonstrated that, through the use of a number of different machine-assistance approaches from slurry handling and cryogenic processing, it is possible to carry out transformational steps that were previously impossible.

Yoshida et al. adopted a microfluidic approach for the control of highly energetic processes which require very low temperatures, specifically targeted at reactions involving organolithium chemistry.<sup>[43]</sup> Their design involved a series of micromixing areas, the simplicity of which led to increased efficiency within the reactor. Microchannels created an environment for rapid mixing at elevated flow rates, thereby allowing for the fast and precise control of reaction events.

One of the most interesting developments in this area has been the use of microfluidics to facilitate flash reactions of lithium species in the presence of “traditionally incompatible” functional groups in a very efficient manner, without the need for protecting groups. This example is a clear demonstration of the advantages associated with the use of micro-scale devices.<sup>[44]</sup> A further relevant example was reported recently, which showed the principle of controlling highly unstable chiral organometallic intermediates to provide a method for the asymmetric carbolithiation of enynes.<sup>[45]</sup>

### 4.2. High Temperatures

The beneficial thermal characteristics afforded by flow systems enable precise temperature control within a reactor, a point discussed in a review on the use of microfluidic

systems at high temperatures and pressures for process intensification.<sup>[46]</sup> Furthermore, operating reactors at high temperatures is a key component of “novel process windows”,<sup>[47]</sup> a concept that describes how uncommon reaction regimes can be incorporated with chemical processes to maximize output.

The most commonly used commercial reactor systems, which have been described in other sections (such as those produced by Vapourtec and Uniqsis), have the ability to conduct experiments at temperatures sufficiently high for the vast majority of chemical reactions. Discussion here is, thus, minimal and limited to developments which adopted what we believe to be different or new approaches.

Pressure considerations must be taken into account when heating solvents to temperatures higher than their boiling points so as to prevent failure of the reactor material.<sup>[48]</sup> This is especially the case in microwave-heated vessels, where supplied energy is absorbed directly by the reactants and solvents, potentially leading to localized superheating and rapid exotherms. Organ's research group has developed a backpressure regulator system that enables their previously reported continuous-flow microwave system to be used at pressures exceeding 73 bar (the boiling point for water at this pressure is 288 °C).<sup>[49]</sup> A gas is used to maintain the pressure, rather than a mechanical part, and so this system is ideal for use in situations where precipitation occurs or where traditional backpressure regulators are exposed to damaging agents. Our group has recently reported a similar device that can be used for the backpressure regulation of fluid streams that contain solids.<sup>[50]</sup>

One of the most original examples of the use of microwaves in organic synthesis was reported in 2006 whereby a flowing-through capillary equipped with a microwave reactor was developed (Figure 10).<sup>[51]</sup> The use of this capillary-microwave reactor has since proved to be effective in delivering a large variety of cross-coupling reactions and nucleophilic substitutions.<sup>[52]</sup>

This system was developed further recently, and additional features were added to facilitate reactions under high temperatures and pressures. Two high-pressure syringe pumps, a reactor tube within a waveguide (the microwave

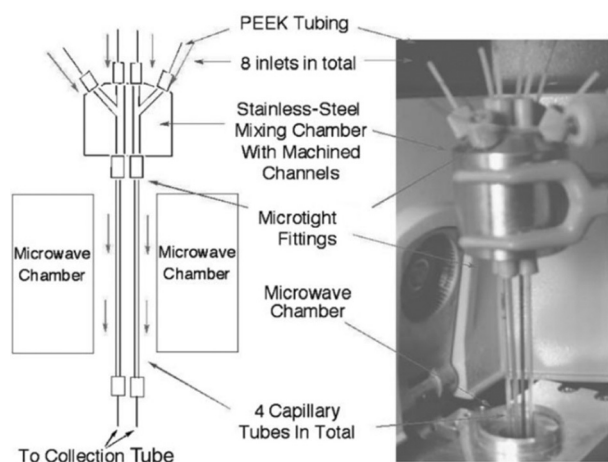

**Figure 10.** A schematic representation and photograph of the first reported capillary microwave flow reactor. Reprinted from Ref. [51].

zone), and a control device that allows precise control of the pressure were fitted to the unit. Its efficacy was demonstrated by a Claisen rearrangement and the synthesis of benzimidazole.<sup>[49]</sup>

An alternative to microwave methods is inductive heating, which is an effective method for heating reactions to high temperatures. Kirschning and co-workers have reported the use of superparamagnetic nanoparticles coated with silica gel and steel beads as efficient materials to use in a fix-bed flow reactor to rapidly achieve high temperatures under exposure to an inductive magnetic field (Figure 11).<sup>[53]</sup>

Inductively heated mesofluidic devices have proven to be very effective in performing a variety of reactions, such as heterocyclic condensations, transfer hydrogenations, pericyclic reactions, cross-couplings, and oxidations, as well as for the preparation of pharmaceutical compounds.<sup>[53,54]</sup>



**Figure 11.** An inductive system used for the machine-assisted heating of a continuous-flow reactor column. Reprinted from Ref. [54a].

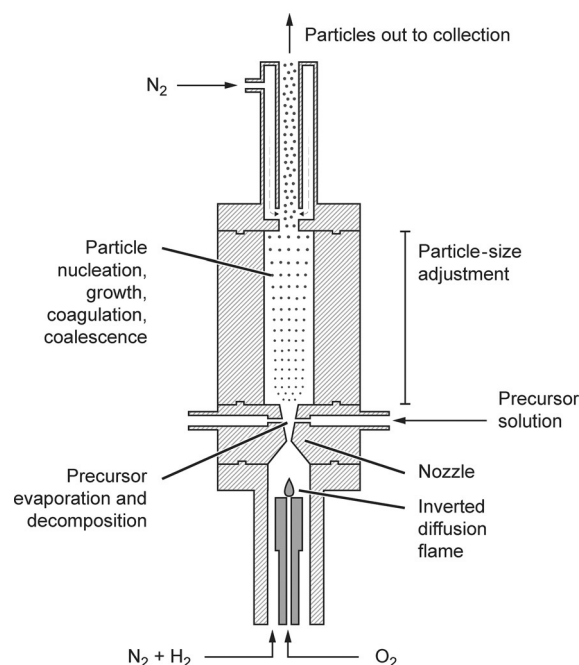

**Figure 12.** Schematic representation of a combustion jet reactor used for the production of metallic nanoparticles from a precursor solution. The size of the particles can be manipulated by adjusting the dimensions of the inner chamber.



The coating of metallic nanoparticles with carbon is receiving interest as a means by which to increase the stability of nanoparticles against degradation processes such as oxidation. A combustion jet reactor has been reported that facilitates the production of carbon-coated copper nanoparticles (Figure 12).<sup>[55]</sup> In this reactor a solution of copper formate, an inexpensive precursor compound, was injected into a fast-moving stream of combustion products from the burning of excess hydrogen with oxygen in a nitrogen environment. At the elevated temperatures found in this gaseous stream (approximately 600 °C), water evaporated from precursor droplets, thereby leaving solid particles of  $\text{Cu}(\text{HCO}_2)_2$ , which subsequently decomposed to  $\text{CuO}$  and  $\text{Cu}_2\text{O}$ . These oxide products were reduced in the hydrogen-rich gas stream to form  $\text{Cu}^0$ . At the same time, the reduction of the decomposition products ( $\text{CO}$  and  $\text{CO}_2$ ) led to the deposition of carbon on the surface of the copper nanoparticles. By adjusting the dimensions of the reactor, it was possible to manipulate the residence time and thus final nanoparticle size. Development of this new machine made it possible to precisely control the product characteristics, which would not have been easy with traditional batch methods.

Plasma reactors are a useful means to synthesize materials under even more extreme conditions. A high-pressure (180–240 Torr) microwave reactor that produces freestanding layers of diamond on silicon substrates has been reported.<sup>[56]</sup> By operating under extreme thermal conditions (950–1150 °C), it was possible to produce diamond of excellent quality with a growth rate of  $21 \mu\text{m h}^{-1}$ . Other recently reported plasma reactors have been used for the synthesis of carbon nanotubes,<sup>[57]</sup> formation of syngas,<sup>[58]</sup> and production of  $\text{H}_2$ .<sup>[59]</sup>

## 5. Enzymes

No modern synthesis laboratory either in research- or industry-scale laboratories should be unaware of the very special reactivity displayed by enzymes during various biotransformations. Further opportunities arise when continuous machine-based processing techniques are applied through immobilization,<sup>[60]</sup> directed evolution methods,<sup>[61]</sup> and when using microfluidic processes.<sup>[62]</sup>

In an early example from our own laboratories, we showed that a ferulic acid amide (prepared by flow equipment), when detected in-line by UV/Vis monitoring, can be passed onto a cartridge containing immobilized horseradish peroxidase to effect a dimerization to the natural product grossamide (Figure 13). This process forms a new C–O and a C–C bond, which we were unable to forge using traditional reagents.<sup>[63]</sup> The enzyme was recycled by co-flowing  $\text{H}_2\text{O}_2$ /urea complex and sodium dihydrogen phosphate buffer in acetone/water (1:4).

A recent publication reviewed the field of machine-assisted coupled chemo(enzymatic) reactions in flow and commented on both the advantages and disadvantages of the process and where they perceive there to be future developments in this area.<sup>[64]</sup> Others have focused on reactor design, particularly microstructured devices with enzymes to bring

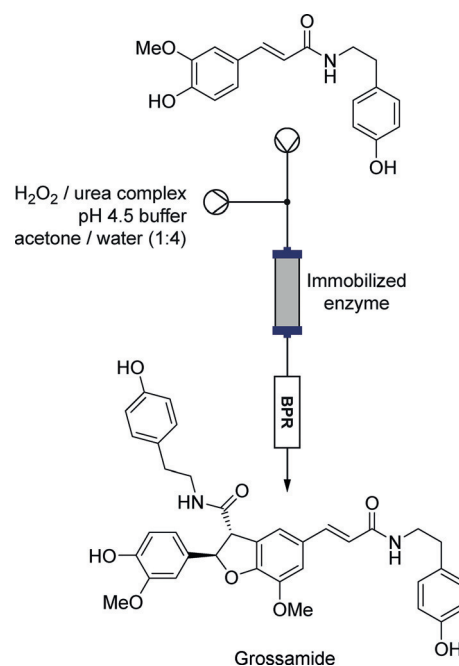
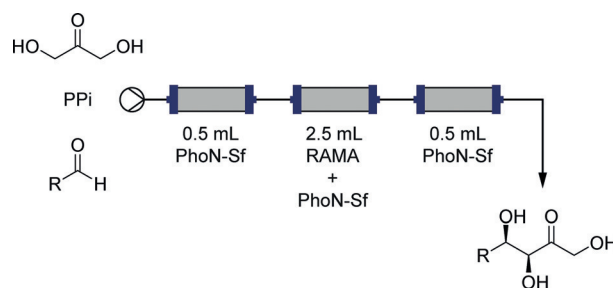

**Figure 13.** Preparation of the natural product grossamide by using immobilized horseradish peroxidase.

about improved biotransformations.<sup>[65]</sup> An especially attractive novel microreactor was designed to enable heterogeneous reactions in a continuous mode, at up to 100 °C in toluene, through ring opening of  $\epsilon$ -caprolactone and its eventual polymerization.<sup>[66]</sup> A packed bed flow reactor had also been used to bring about phosphorylation reactions of alcohols using cheap pyrophosphate as the transfer agent.<sup>[67]</sup> Even more interesting was the use of a three-step flow reactor cascade process to afford carbohydrate products through a phosphorylation/dephosphorylation sequence in quantities of up to a gram (Figure 14).<sup>[68]</sup>

Enzyme and chemical flow steps have been linked together to produce other three-step cascade processes that lead to 1-monoacylglycerol. Of interest here was not the complexity of the processing but rather that the enzyme cartridge loaded with *Rhizomucor miehei* could be recycled up to 18 times without serious loss of activity.<sup>[69]</sup>

Recycling of the enzyme with retention of more than 80% productivity of *Candida antarctica lipase B* (CaLB) after each

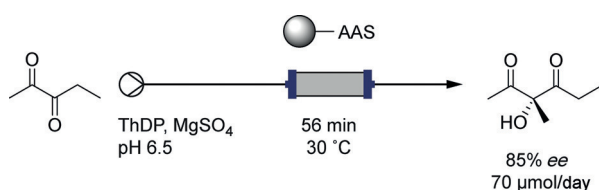

**Figure 14.** Three-step flow cartridge system used for the preparation of carbohydrate products. The middle cartridge can be switched to adjust the chirality of the final compound.

of 8 recycles with an ionic liquid phase and membrane separation during lipase-catalyzed preparation of isoamyl acetate is also possible in a suitable microfluidic reactor system.<sup>[70]</sup> The whole area of microreactors that utilize non-aqueous media for biocatalytic processes had been reviewed recently.<sup>[71]</sup>

A packed-bed microreactor together with acetyl acetoin synthase (AAS) from *Bacillus licheniformis* immobilized on silica (Figure 15) nicely converted diketones into  $\beta$ -keto-hydroxyesters in high enantiomeric excess in the presence of thiamine diphosphate (ThDP).<sup>[72]</sup>

A glutaminase-based encapsulated enzyme system proved most effective during the synthesis of theanine (a simple amino acid; Figure 16). The high enzyme activity was attributed to the accuracy of the local temperature control of the microreactor compared to batch-mode processing.<sup>[73]</sup>



**Figure 15.** Preparation of a  $\beta$ -keto-hydroxyester from a diketone using immobilized acetyl acetoin synthase.

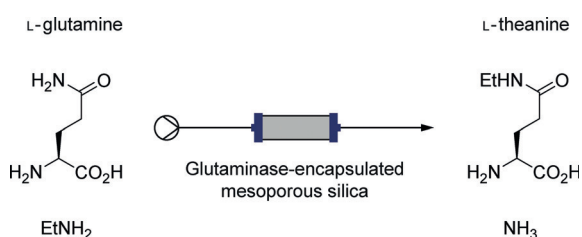

**Figure 16.** Encapsulated glutaminase has been used during the synthesis of theanine. Increased temperature control of such a reactor system led to higher than normal enzyme activity.

This study was followed up by further more detailed studies, in which recombinant glutaminase SBA microsphere composites derived from *Pseudomonas nitroreducens* were used, again demonstrating the power of the novel microreactor to precisely control the reaction parameters during continuous-flow processing.<sup>[74]</sup>

## 6. Managing Slurries

With the widespread adoption of flow chemistry platforms for research, development, and discovery, we are increasingly focused on solving the most common challenges arising in a laboratory environment. For example, in many reaction scenarios there is a great risk of forming particulate matter—as a starting material, intermediate, by-product, or final product. Some innovative approaches and discussion on new equipment for managing solids in continuous flow have been

detailed in a recent review, and demonstrates the effort and energy being expended to tackle this issue.<sup>[75]</sup>

A particular challenge in upstream processing is the understanding and managing of heterogeneous flow and reactions. Interestingly, this is not significantly different to the challenges with micro- and mesoscale laminar flow faced by the natural gas and petroleum industries, which are accustomed, as well as prepared, to manage particulate matter.

In addition to particulate matter constrained within flow streams, there are the more general challenges presented by deposition, growth, and bridging on surfaces, for example, at backpressure regulators or in and around in-line analytical instruments as well as in small-gauge transfer tubing. Frequently, the strategy used to avoid these problems in flow is to mitigate the potential for obstruction by introducing additional solubilizing agents to the flow stream immediately before the problematic stage or provide some form of inline agitation.

Since this area has been recently reviewed, we will highlight just two alternative approaches for managing solids in flow. The first of these looks at common salt-forming reactions, typified in the preparation of many active pharmaceutical ingredients (APIs), for example. In 2011 our group evaluated the use of a commercially available agitated cell reactor (Coflore ACR, Figure 17a) in the formation of the hydroiodide salt of *N*-iodomorpholine, which is a source of electrophilic iodine and thus a useful iodinating agent, through the reaction of morpholine with iodine (Figure 17b).<sup>[76]</sup>

The hydroiodide salt of *N*-iodomorpholine was accomplished at a rate of  $12 \text{ mL min}^{-1}$  as a 0.1M solution (i.e. the equivalent of a 94% yield) which, on extrapolation, corresponds to a production capacity of around  $3.8 \text{ kg week}^{-1}$ .

The excellent results obtained were due to the superior ability of the agitated cell reactor to mix the reagents

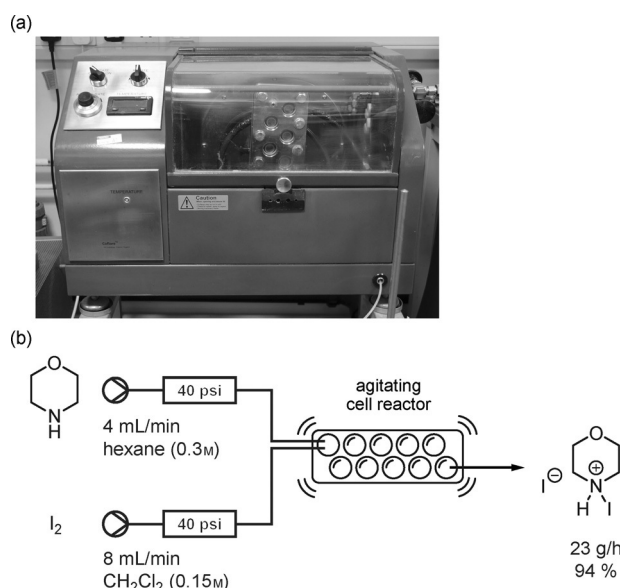

**Figure 17.** a) The Coflore ACR is used for reactions that include slurries or involve precipitation of significant quantities of solids. b) Equipment layout used for the preparation of a hydroiodide salt product.

effectively when compared to the analogous batch process. The agitator uses transverse mixing motion, without the need for mixing baffles, to keep particulate matter in suspension. The reactor is a specifically designed flow device based on the continuous tank reactor (CSTR) principle. It features a reaction block mounted on a laterally shaking motor, with the block itself containing freely moving agitators. The use of transverse mixing avoids the centrifugal separation problems

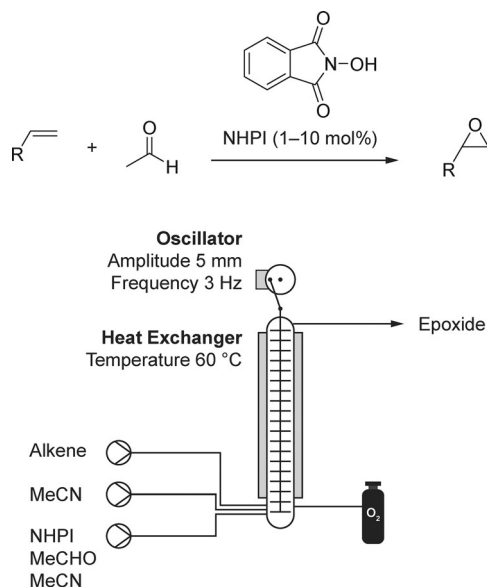

**Figure 18.** The Multijet Oscillating Disc microreactor (MJOD) promotes excellent mixing through the axial movement of a series of perforated discs in a liquid stream.

associated with the conventional rotational mixing of materials of different densities. Another Coflore reactor, which uses tubes rather than cells, has been used to scale up biocatalytic oxidase processes.<sup>[77]</sup>

In contrast to the transverse mode of operation of the above-described Coflore ACR, another interesting approach has been the development of the multijet oscillating disc microreactor (MJOD, Figure 18), a device specifically developed for flow chemistry on a millisecond scale.<sup>[78]</sup> The MJOD is fitted with an adjustable amplitude and frequency oscillator that moves the multijet reactor tube of the disc assembly forward and backward in the longitudinal (axial) direction of the reactor, analogous to a piston engine with multiple piston heads on a single piston shaft. Each piston head (the discs) is furnished with several jets. Some 60–100 perforated discs are fixed at equal distances on the shaft of the MJOD unit. Reactants, introduced through inlet lines fitted with one-way valves, are forced through at high pres-

sure through the perforations. As the spray enters the reaction chamber the flow rate decreases, which promotes the formation of vortices, thus resulting in enhanced mixing.

The MJOD developers report the outcomes of using this mixing device in a respectable array of useful reactions, such as the haloform and Nef reactions, nucleophilic aromatic substitution, the Paal–Knorr pyrrole synthesis, NaBH<sub>4</sub> reduction, O-allylation, Suzuki cross-coupling reactions, Hofmann rearrangement, and N-acetylations. This was followed by an interesting example of using the MJOD in an organocatalytic Minisci epoxidation of olefins, which provided superior results compared to its batch-phase counterpart, with a continuous-flow production capacity in the order of 80 g day<sup>-1</sup>.<sup>[79]</sup>

## 7. Managing Organometallic Compounds

The lack of economically viable process strategies, which understandably still tend to rely heavily on multipurpose batch reactors, hampers the more widespread use of organometallic catalysts and reagents. As such, they have largely remained more specialist tools within the chemical industry. The metals that are used are expensive and there are also issues with product purity, toxicity, catalyst separation, and recovery. Adopting a continuous-flow approach for reactions containing organometallic compounds provides very favorable steady-state conditions at each step, such as constant temperature, flow rate, and substrate concentrations. However, some significant challenges remain in doing this operationally, for example, development of a suitable catalyst, an effective catalysts/product separation strategy, and a feasible continuous-flow synthesis strategy.

Various separation approaches using near-critical and supercritical fluids in flow have been reviewed.<sup>[80]</sup> Furthermore, a selection of interesting reactions using metal-based reagents and catalysts in synthesis processes in flow-chemistry platforms have also been reviewed, which includes discussion on nonsupported catalysts and catalysts supported on ionic liquid phases, dendrimers, and magnetic nanoparticles.<sup>[81]</sup> In addition, a very recent review discussed methods that can be used for the separation and recycling of catalysts in homogeneous organocatalytic systems.<sup>[82]</sup>

In 2012, our group made pioneering use of the Mettler–Toledo microscale ReactIR flow cell as an inline analytical

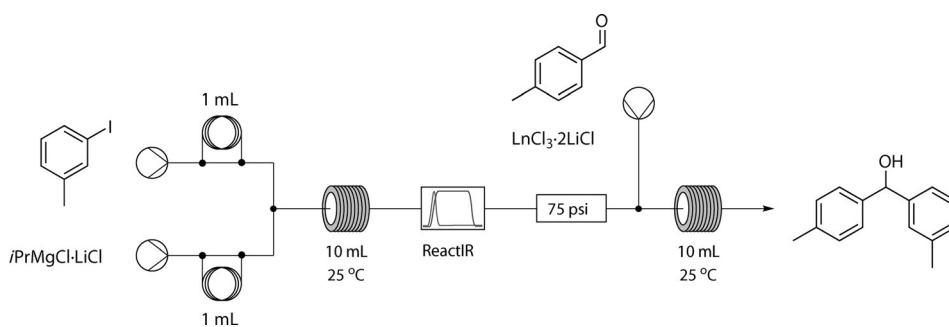

**Figure 19.** An R2/R4+ reactor system and FlowIR were combined to effectively manage organometallic reagents in continuous-flow reactions.

tool to devise a new flow-chemistry approach useful for the preparation of Grignard reagents that were not commercially available.<sup>[83]</sup> We exemplified the strategy with a LiCl-mediated halogen–Mg exchange reaction, performed using a Vapourtec R2/R4+ reactor unit, to prepare functionalized aryl–Mg compounds from aryl iodides and bromides (Figure 19). This study also showed how adopting a machine-assisted flow approach was an effective system for managing highly exothermic reactions through fast mixing and efficient heat transfer.

Access to 2-trimethylsilylphenyl triflate precursors is necessary in the field of aryl chemistry. However, there are only a few, somewhat tricky procedures to access them using traditional synthesis methods. One particular step in their preparation involves an *n*-butyllithium-initiated Brook rearrangement, which is often accompanied by problematic side reactions. These have been shown to be avoidable by taking the synthesis of these valuable precursors into flow.<sup>[84]</sup>

Metalation of functionalized pyridines, pyrimidines, thiophenes, thiazoles, and highly sensitive functionalized acrylates using the non-nucleophilic base TMPMgCl–LiCl has been shown to provide excellent opportunities to access materials more efficiently, including those that could not be generated under batch conditions.<sup>[85]</sup>

Other useful building blocks, such as ketones derived from CO<sub>2</sub> and organolithium or Grignard reagents by a telescoped 3-step one-flow process, have also been reported.<sup>[86]</sup>

The above represent a few examples from the recent literature of how flow approaches have made it easier to access and incorporate organometallic compounds into synthesis efforts. Generally speaking, many of the examples have been limited to simple reactions or the preparation of precursors. Now that there are specialized commercially available peristaltic pumping systems that can be used specifically for flow chemistry, more and greater product complexity can be expected.

In 2013 we reported on the first major application of a peristaltic pumping system, which pumped at smooth flow rates and elevated pressures, to provide reproducible access to organometallic reagents on a multigram scale from air-sensitive reagents.<sup>[87]</sup> This enabled us to prepare in a telescoped fashion, as an example, the breast cancer drug tamoxifen in quantities suitable to treat 20000 patients per day of output.

The concept of generating organolithium species in a microfluidic environment has been extensively developed and reported by the research group of Yoshida. His group has pioneered the concept of “Flash Chemistry”, which is directly related to these transformations and primarily carried out under cryogenic conditions (see Section 4.1).<sup>[88]</sup>

## 8. Electrocatalytic Reactors

The integration of electrochemical synthesis techniques into flow chemistry, thereby enabling the utilization of electrons and other reactive species such as carbanions, carbocations, and radicals, has been made possible by the development of specifically designed flow-based electrochemical microreactors. The reactors have generally been designed to eliminate chemical hot spots, as the reaction solution flowing between the electrodes sets up a homogeneous current density. Solid plate-to-plate undivided cells are the most straightforward of the designs for electrolysis at a constant current. There are also undivided packed-bed cells, as well as more sophisticated divided-cell microreactors, which are necessary when there is a need to keep the two electrode compartments separate. The many varied designs of these efficient electrochemical microreactors have been reviewed recently in detail,<sup>[89]</sup> as have fabrication techniques and materials used in the miniaturization of electrochemical flow devices.<sup>[90]</sup>

Given the recent proliferation of flow-based access to electrochemical reactions, there has undoubtedly been a rapid uptake by researchers keen to use these easy-to-generate, clean, and efficient reactive species in their synthesis and analysis programs.

Our group also recently reported how using a key electrochemical Shono oxidation in flow enabled efficient access to a number of unnatural analogues of the alkaloid nazlinine (Figure 20).<sup>[91]</sup> The choice of incorporating electro-

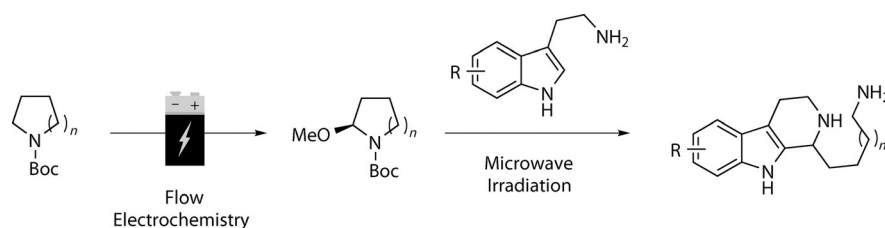

**Figure 20.** Synthesis of nazlinine and unnatural congeners by a two-step, electrocatalyzed and microwave process.



**Figure 21.** The commercially available Syrris Asia electrocatalytic reactor system.

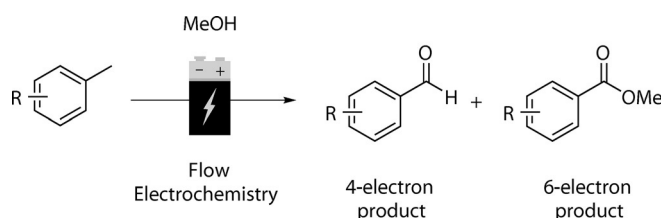

**Figure 22.** A modular plate-based microfluidic cell has been used for benzylic methoxylation and oxidation.

chemistry in this instance, by using a commercially available unit (Figure 21), meant substoichiometric loadings of electrolyte (20 mol%) were sufficient to effect the necessary reactions.

Continuous-flow electrochemical techniques in a microfluidic setting have also been used to good advantage in a mimicked first pass hepatic oxidation with CYP450.<sup>[92]</sup> This rapid process was used to analyze metabolites of a number of commercially available drugs (diclofenac, tolbutamide, primidone, albendazole, and chlorpromazine). This study demonstrates how flow electrochemistry could be integrated into making and screening programs focused on new drug scaffolds to assess, in this case, oxidative liabilities prior to further in vitro and certainly in vivo testing.

Another example of both reactor design and exemplification through application include a direct continuous-flow electrochemical procedure for benzylic methoxylation (4-electron product) and oxidation (6-electron product) by using a modular plate-based microfluidic cell (Figure 22).<sup>[93]</sup> This example is interesting, since it demonstrates how electrolysis at constant current, specifically in flow, enables control or, at best, modulation of substrate over-oxidation by removal of the desired products.

Site-selective electroreductive deprotection of the isonicotinylxycarbonyl group from amino, thiol, and hydroxy groups has been reported, whereby distinction between O- and S-*i*Noc groups could be made over N-*i*Noc moieties because of the fast reaction times resulting from the very small distance between the platinum electrodes.<sup>[94]</sup>

## 9. Photocatalytic Reactors

The use of photons as an energy source for reactions is an area that has been well-reviewed previously in a number of publications that focus on applications ranging from continuous-flow processing techniques<sup>[95]</sup> to synthesis mediated by organometallic compounds.<sup>[96]</sup> Accordingly, we have limited the discussion of photochemical reactor studies here to only those which have directly involved novel reactor types or machinery in some way.

A recent study investigated the efficacy of five reactor designs for carrying out ene reactions with singlet oxygen. The systems tested (Figure 23) were chosen so as to give an insight into design parameters for photocatalyzed microreactors and were comprised of an immersed well reactor (batch mode), a recirculating annular reactor, and three microchip-based reaction systems. It was found that the excellent mixing

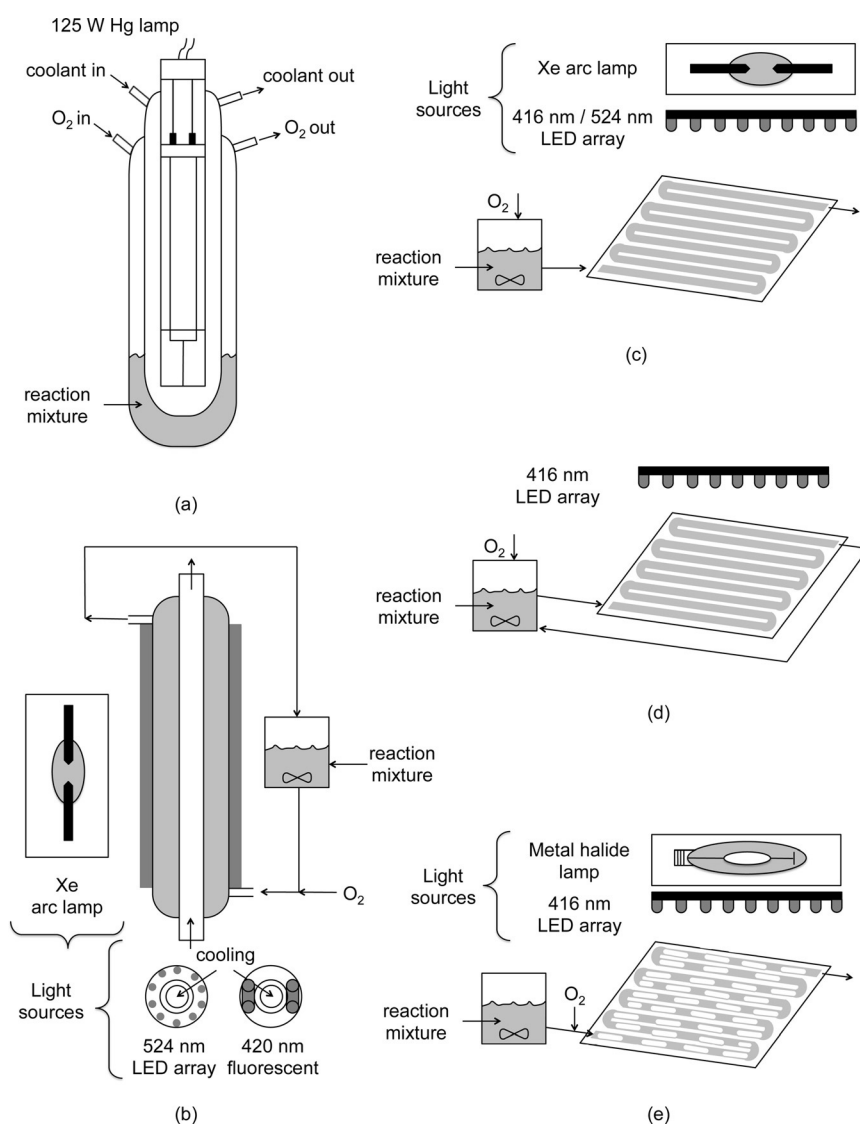

**Figure 23.** The efficiencies of five reactor configurations were tested: a) an immersed well, batch-mode reactor; b) a recirculating annular reactor; c) a microfluidic single pass reactor; d) a microfluidic recirculating reactor; and e) a biphasic-flow, single-pass microfluidic system. Reprinted from Ref. [97] with permission. Copyright 2014, American Chemical Society.

conditions and the large surface area to volume ratio inherent to the microreactor systems lead to more efficient product formation for the oxygenation of  $\alpha$ -pinene to pinocarvone.<sup>[97]</sup>

Another team has reported the development of a photochemical system that can incorporate a range of switchable filters to enhance reaction workflows.<sup>[98]</sup> By varying the UV wavelength and the reaction sensitizer, temperature, and solvent it was possible to perform multidimensional reaction screening for multiple substrates more efficiently than traditional methods.

## 10. Summary and Outlook

In combination with our previous review<sup>[1]</sup>, this new Review gives an overall vision of how various machine-based technologies are impinging on our daily work in modern research laboratories. This “machine-assisted” approach seeks to enhance the synthesis process by creating a productive environment for discovery. The ability to optimize and more rapidly scale-up experiments in a safe fashion provides greater continuity across different working regimes. Nevertheless, there is a reluctance by parts of the chemical research community to adopt these methods, since they constitute a disruptive technology and a massive change in the philosophy of synthesis. In time, and with intelligent integration, many of the labor-intensive tasks and data manipulation will, by necessity, be relegated to machine-processing methods. More interestingly, we will see application of the smart technologies and of all the components our modern world can offer. The “Internet of Things”, computational capability, advanced engineering, wearable devices, and implants will all have an impact. Continuous processing, in-line analytics, information feedback, and control make sense when driving a more-sustainable agenda. In our view, the tools, as well as the methods, of synthesis must move on from where we are today to a new level of opportunity and responsibility.

*We gratefully acknowledge support from the UK Engineering and Physical Sciences Research Council (S.V.L. and R.M.M.), Woolf Fisher Trust (D.E.F.), and Pfizer Worldwide Research and Development (C.B., R.J.I.).*

**How to cite:** *Angew. Chem. Int. Ed.* **2015**, *54*, 10122–10136  
*Angew. Chem.* **2015**, *127*, 10260–10275

- [1] S. V. Ley, D. E. Fitzpatrick, R. J. Ingham, R. M. Myers, *Angew. Chem. Int. Ed.* **2015**, *54*, 3449–3464; *Angew. Chem.* **2015**, *127*, 3514–3530.
- [2] For more information about the Internet of Things, see [http://www.mckinsey.com/insights/high\\_tech\\_telecoms\\_internet/the\\_internet\\_of\\_things](http://www.mckinsey.com/insights/high_tech_telecoms_internet/the_internet_of_things).
- [3] The most popular microcomputer devices used for IoT applications include the Arduino (<http://www.arduino.cc>) and Raspberry Pi (<http://www.raspberrypi.org>).
- [4] A. Kirschning, W. Solodenko, K. Mennecke, *Chem. Eur. J.* **2006**, *12*, 5972–5990.
- [5] G. A. Leeke, B. Al-Duri, J. P. K. Seville, C. J. Smith, C. K. Y. Lee, A. B. Holmes, I. F. McConvey, *Org. Process Res. Dev.* **2007**, *11*, 144–148.
- [6] X. Meng, H. Cheng, S. Fujita, Y. Hao, Y. Shang, Y. Yu, S. Cai, F. Zhao, M. Arai, *J. Catal.* **2010**, *269*, 131–139.
- [7] Y.-T. Tsai, H. Lin, M.-J. Lee, *Bioresour. Technol.* **2013**, *145*, 362–369.
- [8] F. Guzmán-Lagunes, A. López-Luna, M. Gimeno, E. Bárzana, *J. Supercrit. Fluids* **2012**, *72*, 186–190.
- [9] a) T. Adschiri, Y.-W. Lee, M. Goto, S. Takami, *Green Chem.* **2011**, *13*, 1380; b) A. Loppinet-Serani, C. Aymonier, F. Cansell, *J. Chem. Technol. Biotechnol.* **2010**, *85*, 583–589.
- [10] J.-M. Ha, D. Kim, J. Kim, S. K. Kim, B. S. Ahn, J. W. Kang, *Chem. Eng. J.* **2012**, *213*, 346–355.
- [11] a) S. Marre, Y. Roig, C. Aymonier, *J. Supercrit. Fluids* **2012**, *66*, 251–264; b) P. Lozano, E. Garcia-Verdugo, S. V. Luis, M. Pucheault, M. Vaultier, *Curr. Org. Synth.* **2011**, *8*, 810–823; c) X. Han, M. Poliakoff, *Chem. Soc. Rev.* **2012**, *41*, 1428–1436.
- [12] S. C. Stouten, T. Noël, Q. Wang, V. Hessel, *Chem. Eng. Prog.* **2014**, *83*, 26–32.
- [13] J. F. B. Hall, R. A. Bourne, X. Han, J. H. Earley, M. Poliakoff, M. W. George, *Green Chem.* **2013**, *15*, 177–180.
- [14] J. G. Stevens, R. A. Bourne, M. V. Twigg, M. Poliakoff, *Angew. Chem. Int. Ed.* **2010**, *49*, 8856–8859; *Angew. Chem.* **2010**, *122*, 9040–9043.
- [15] C. Yan, J. Fraga-Dubreuil, E. Garcia-Verdugo, P. A. Hamley, M. Poliakoff, I. Pearson, A. S. Coote, *Green Chem.* **2008**, *10*, 98–103.
- [16] U. Hintermair, C. Roosen, M. Kaever, H. Kronenberg, R. Thelen, S. Aey, W. Leitner, L. Greiner, *Org. Process Res. Dev.* **2011**, *15*, 1275–1280.
- [17] T. Noël, V. Hessel, *ChemSusChem* **2013**, *6*, 405–407.
- [18] a) M. O'Brien, I. R. Baxendale, S. V. Ley, *Org. Lett.* **2010**, *12*, 1596–1598; b) M. Brzozowski, M. O'Brien, S. V. Ley, A. Polyzos, *Acc. Chem. Res.* **2015**, *48*, 349–362.
- [19] S. L. Bourne, P. Koos, M. O'Brien, B. Martin, B. Schenkel, I. R. Baxendale, S. V. Ley, *Synlett* **2011**, 2643–2647.
- [20] P. B. Cranwell, M. O'Brien, D. L. Browne, P. Koos, A. Polyzos, M. Peña-López, S. V. Ley, *Org. Biomol. Chem.* **2012**, *10*, 5774–5779.
- [21] D. L. Browne, M. O'Brien, P. Koos, P. B. Cranwell, A. Polyzos, S. V. Ley, *Synlett* **2012**, *23*, 1402–1406.
- [22] J. C. Pastre, D. L. Browne, M. O'Brien, S. V. Ley, *Org. Process Res. Dev.* **2013**, *17*, 1183–1191.
- [23] S. Kasinathan, S. L. Bourne, P. Tolstoy, P. Koos, M. O'Brien, R. Bates, I. R. Baxendale, S. V. Ley, *Synlett* **2011**, 2648–2651.
- [24] A. Polyzos, M. O'Brien, T. P. Petersen, I. R. Baxendale, S. V. Ley, *Angew. Chem. Int. Ed.* **2011**, *50*, 1190–1193; *Angew. Chem.* **2011**, *123*, 1222–1225.
- [25] M. O'Brien, N. Taylor, A. Polyzos, I. R. Baxendale, S. V. Ley, *Chem. Sci.* **2011**, *2*, 1250–1257.
- [26] T. P. Petersen, A. Polyzos, M. O'Brien, T. Ulven, I. R. Baxendale, S. V. Ley, *ChemSusChem* **2012**, *5*, 274–277.
- [27] P. Koos, U. Gross, A. Polyzos, M. O'Brien, I. R. Baxendale, S. V. Ley, *Org. Biomol. Chem.* **2011**, *9*, 6903–6908.
- [28] U. Gross, P. Koos, M. O'Brien, A. Polyzos, S. V. Ley, *Eur. J. Org. Chem.* **2014**, 6418–6430.
- [29] For more information, see <http://www.cambridgereactor design.com/>.
- [30] M. A. Mercadante, N. E. Leadbeater, *Org. Biomol. Chem.* **2011**, *9*, 6575–6578.
- [31] J. J. F. van Gool, S. A. M. W. van den Broek, R. M. Ripken, P. J. Nieuwland, K. Koch, F. P. J. T. Rutjes, *Chem. Eng. Technol.* **2013**, *36*, 1042–1046.
- [32] R. A. Maurya, C. P. Park, J. H. Lee, D.-P. Kim, *Angew. Chem. Int. Ed.* **2011**, *50*, 5952–5955; *Angew. Chem.* **2011**, *123*, 6074–6077.
- [33] C. P. Park, D.-P. Kim, *J. Am. Chem. Soc.* **2010**, *132*, 10102–10106.
- [34] D. Sannino, V. Vaiano, P. Ciambelli, *Res. Chem. Intermed.* **2013**, *39*, 4145–4157.

- [35] M. P. Gimeno, J. Soler, J. Herguido, M. Menéndez, *Ind. Eng. Chem. Res.* **2010**, *49*, 6810–6814.
- [36] M. Irfan, T. N. Glasnov, C. O. Kappe, *ChemSusChem* **2011**, *4*, 300–316.
- [37] T. Ouchi, C. Battilocchio, J. M. Hawkins, S. V. Ley, *Org. Process Res. Dev.* **2014**, *18*, 1560–1566.
- [38] D. L. Browne, M. Baumann, B. H. Harji, I. R. Baxendale, S. V. Ley, *Org. Lett.* **2011**, *13*, 3312–3315.
- [39] K. Nakayama, D. L. Browne, I. R. Baxendale, S. V. Ley, *Synlett* **2013**, *24*, 1298–1302.
- [40] a) J. A. Newby, D. W. Blaylock, P. M. Witt, R. M. Turner, P. L. Heider, B. H. Harji, D. L. Browne, S. V. Ley, *Org. Process Res. Dev.* **2014**, *18*, 1221–1228; b) J. A. Newby, D. W. Blaylock, P. M. Witt, J. C. Pastre, M. K. Zacharova, S. V. Ley, D. L. Browne, *Org. Process Res. Dev.* **2014**, *18*, 1211–1220.
- [41] D. L. Browne, B. H. Harji, S. V. Ley, *Chem. Eng. Technol.* **2013**, *36*, 959–967.
- [42] D. Sleveland, H.-R. Bjørsvik, *Org. Process Res. Dev.* **2012**, *16*, 1121–1130.
- [43] J. Yoshida, Y. Takahashi, A. Nagaki, *Chem. Commun.* **2013**, *49*, 9896–9904.
- [44] H. Kim, A. Nagaki, J. Yoshida, *Nat. Commun.* **2011**, *2*, 264.
- [45] Y. Tomida, A. Nagaki, J. Yoshida, *J. Am. Chem. Soc.* **2011**, *133*, 3744–3747.
- [46] T. Razaq, C. O. Kappe, *Chem. Asian J.* **2010**, *5*, 1274–1289.
- [47] a) V. Hessel, D. Kralisch, N. Kockmann, T. Noël, Q. Wang, *ChemSusChem* **2013**, *6*, 746–789; b) S. C. Stouten, T. Noël, Q. Wang, V. Hessel, *Aust. J. Chem.* **2013**, *66*, 121–130.
- [48] a) I. R. Baxendale, J. J. Hayward, S. V. Ley, *Comb. Chem. High Throughput Screening* **2007**, *10*, 802–836; b) M. Baumann, I. Baxendale, S. V. Ley, *Synlett* **2008**, 2111–2114.
- [49] J. M. Sauks, D. Mallik, Y. Lawryshyn, T. Bender, M. Organ, *Org. Process Res. Dev.* **2014**, *18*, 1310–1314.
- [50] B. J. Deadman, D. L. Browne, I. R. Baxendale, S. V. Ley, *Chem. Eng. Technol.* **2015**, *38*, 259–264.
- [51] G. Shore, S. Morin, M. G. Organ, *Angew. Chem. Int. Ed.* **2006**, *45*, 2761–2766; *Angew. Chem.* **2006**, *118*, 2827–2832.
- [52] a) E. Comer, M. G. Organ, *J. Am. Chem. Soc.* **2005**, *127*, 8160–8167; b) Q. Zang, S. Javed, D. Hill, F. Ullah, D. Bi, P. Porubsky, B. Neuenswander, G. H. Lushington, C. Santini, M. G. Organ, P. R. Hanson, *ACS Comb. Sci.* **2012**, *14*, 456–459; c) Q. Zang, S. Javed, P. Porubsky, F. Ullah, B. Neuenswander, G. H. Lushington, F. Z. Basha, M. G. Organ, P. R. Hanson, *ACS Comb. Sci.* **2012**, *14*, 211–217; d) S. Achanta, V. Liautard, R. Paugh, M. G. Organ, *Chem. Eur. J.* **2010**, *16*, 12797–12800.
- [53] S. Ceylan, L. Coutable, J. Wegner, A. Kirschning, *Chem. Eur. J.* **2011**, *17*, 1884–1893.
- [54] a) J. Hartwig, S. Ceylan, L. Kupracz, L. Coutable, A. Kirschning, *Angew. Chem. Int. Ed.* **2013**, *52*, 9813–9817; *Angew. Chem.* **2013**, *125*, 9995–9999; b) S. R. Chaudhuri, J. Hartwig, L. Kupracz, T. Kodanek, J. Wegner, A. Kirschning, *Adv. Synth. Catal.* **2014**, *356*, 3530–3538; c) L. Kupracz, A. Kirschning, *Adv. Synth. Catal.* **2013**, *355*, 3375–3380; d) L. Kupracz, A. Kirschning, *J. Flow Chem.* **2013**, *3*, 10–16.
- [55] W. J. Scharmach, R. D. Buchner, V. Papavassiliou, P. Pacouloute, M. T. Swihart, *Aerosol Sci. Technol.* **2010**, *44*, 1083–1088.
- [56] K. W. Hemawan, T. A. Grotjohn, D. K. Reinhard, J. Asmussen, *Diamond Relat. Mater.* **2010**, *19*, 1446–1452.
- [57] K. Bystrov, M. C. van de Sanden, C. Arnas, L. Marot, D. Mathys, F. Liu, L. K. Xu, X. B. Li, A. V. Shalpegin, G. De Temmerman, *Carbon* **2014**, *68*, 695–707.
- [58] V. Grigaitienė, V. Snapkauskienė, P. Valatkevičius, A. Tamosiūnas, V. Valinčius, *Catal. Today* **2011**, *167*, 135–140.
- [59] N. Bundaleska, D. Tsyganov, R. Saavedra, E. Tatarova, F. M. Dias, C. M. Ferreira, *Int. J. Hydrogen Energy* **2013**, *38*, 9145–9157.
- [60] K. Ariga, Q. Ji, T. Mori, M. Naito, Y. Yamauchi, H. Abe, J. P. Hill, *Chem. Soc. Rev.* **2013**, *42*, 6322–6345.
- [61] a) M. T. Reetz, *J. Am. Chem. Soc.* **2013**, *135*, 12480–12496; b) M. T. Reetz, *Angew. Chem. Int. Ed.* **2011**, *50*, 138–174; *Angew. Chem.* **2011**, *123*, 144–182.
- [62] V. Hessel, J. Tibhe, T. Noël, Q. Wang, *Chem. Biochem. Eng. Q.* **2014**, *28*, 167–188.
- [63] I. R. Baxendale, C. M. Griffiths-Jones, S. V. Ley, G. K. Tranmer, *Synlett* **2006**, 427–430.
- [64] R. Yuryev, S. Strompen, A. Liese, *Beilstein J. Org. Chem.* **2011**, *7*, 1449–1467.
- [65] a) J. M. Bolivar, J. Wiesbauer, B. Nidetzky, *Trends Biotechnol.* **2011**, *29*, 333–342; b) J. M. Bolivar, B. Nidetzky, *Chim. Oggi/Chem. Today* **2013**, *31*, 50–54.
- [66] S. Kundu, A. S. Bhangale, W. E. Wallace, K. M. Flynn, C. M. Guttman, R. A. Gross, K. L. Beers, *J. Am. Chem. Soc.* **2011**, *133*, 6006–6011.
- [67] L. Babich, A. F. Hartog, M. A. van der Horst, R. Wever, *Chem. Eur. J.* **2012**, *18*, 6604–6609.
- [68] L. Babich, A. F. Hartog, L. J. C. van Hemert, F. P. J. T. Rutjes, R. Wever, *ChemSusChem* **2012**, *5*, 2348–2353.
- [69] I. Itabaiana, I. C. R. Leal, L. S. M. Miranda, R. O. M. A. Souza, *J. Flow Chem.* **2013**, *3*, 122–126.
- [70] U. Novak, P. Žnidarsič-Plazl, *Green Process. Synth.* **2013**, *2*, 561–568.
- [71] P. Žnidarsič-Plazl, *Chim. Oggi/Chem. Today* **2014**, *32*, 54–60.
- [72] P. P. Giovannini, O. Bortolini, A. Cavazzini, R. Greco, G. Fantin, A. Massi, *Green Chem.* **2014**, *16*, 3904–3915.
- [73] S. Matsuura, T. Yokoyama, R. Ishii, T. Itoh, E. Tomon, S. Hamakawa, T. Tsunoda, F. Mizukami, H. Nanbu, T. Hanaoka, *Chem. Commun.* **2012**, *48*, 7058–7060.
- [74] S. Matsuura, M. Chiba, E. Tomon, T. Tsunoda, *RSC Adv.* **2014**, *4*, 9021–9030.
- [75] R. L. Hartman, *Org. Process Res. Dev.* **2012**, *16*, 870–887.
- [76] D. L. Browne, B. J. Deadman, R. Ashe, I. R. Baxendale, S. V. Ley, *Org. Process Res. Dev.* **2011**, *15*, 693–697.
- [77] G. Gasparini, I. Archer, E. Jones, R. Ashe, *Org. Process Res. Dev.* **2012**, *16*, 1013–1016.
- [78] L. Liguori, H.-R. Bjørsvik, *Org. Process Res. Dev.* **2011**, *15*, 997–1009.
- [79] R. Spaccini, L. Liguori, C. Punta, H.-R. Bjørsvik, *ChemSusChem* **2012**, *5*, 261–265.
- [80] U. Hintermair, G. Franciò, W. Leitner, *Chem. Commun.* **2011**, *47*, 3691–3701.
- [81] T. Chinnusamy, S. S. Yudha, M. Hager, P. Kreitmeier, O. Reiser, *ChemSusChem* **2012**, *5*, 247–255.
- [82] I. V. Gürsel, T. Noël, Q. Wang, V. Hessel, *Green Chem.* **2015**, *17*, 2012–2026.
- [83] T. Brodmann, P. Koos, A. Metzger, P. Knochel, S. V. Ley, *Org. Process Res. Dev.* **2012**, *16*, 1102–1113.
- [84] B. Michel, M. F. Greaney, *Org. Lett.* **2014**, *16*, 2684–2687.
- [85] T. P. Petersen, M. R. Becker, P. Knochel, *Angew. Chem. Int. Ed.* **2014**, *53*, 7933–7937; *Angew. Chem.* **2014**, *126*, 8067–8071.
- [86] J. Wu, X. Yang, Z. He, X. Mao, T. A. Hatton, T. F. Jamison, *Angew. Chem. Int. Ed.* **2014**, *53*, 8416–8420; *Angew. Chem.* **2014**, *126*, 8556–8560.
- [87] P. R. D. Murray, D. L. Browne, J. C. Pastre, C. Butters, D. Guthrie, S. V. Ley, *Org. Process Res. Dev.* **2013**, *17*, 1192–1208.
- [88] J.-i. Yoshida, *Flash Chemistry: Fast Organic Synthesis in Microsystems*, Wiley, Hoboken, NJ, **2008**.
- [89] K. Watts, A. Baker, T. Wirth, *J. Flow Chem.* **2014**, *4*, 2–11.
- [90] F. J. del Campo, *Electrochem. Commun.* **2014**, *45*, 91–94.
- [91] M. A. Kabeshov, B. Musio, P. R. D. Murray, D. L. Browne, S. V. Ley, *Org. Lett.* **2014**, *16*, 4618–4621.
- [92] R. Stalder, G. P. Roth, *ACS Med. Chem. Lett.* **2013**, *4*, 1119–1123.

- [93] G. P. Roth, R. Stalder, T. R. Long, D. R. Sauer, S. W. Djuric, *J. Flow Chem.* **2013**, 3, 34–40.
- [94] K. Arai, T. Wirth, *Org. Process Res. Dev.* **2014**, 18, 1377–1381.
- [95] a) Y. Su, N. J. W. Straathof, V. Hessel, T. Noël, *Chem. Eur. J.* **2014**, 20, 10562–10589; b) J. P. Knowles, L. D. Elliott, K. I. Booker-Milburn, *Beilstein J. Org. Chem.* **2012**, 8, 2025–2052; c) K. Gilmore, P. H. Seeberger, *Chem. Rec.* **2014**, 14, 410–418.
- [96] N. Hoffmann, *ChemSusChem* **2012**, 5, 352–371.
- [97] K. N. Loponov, J. Lopes, M. Barlog, E. V. Astrova, A. V. Malkov, A. A. Lapkin, *Org. Process Res. Dev.* **2014**, 18, 1443–1454.
- [98] V. I. Martin, J. R. Goodell, O. J. Ingham, J. A. Porco, A. B. Beeler, *J. Org. Chem.* **2014**, 79, 3838–3846.

Received: February 18, 2015  
Published online: July 16, 2015

---