

# Maternal separation stress leads to resilience against neuropathic pain in adulthood

Julien Genty\*, Milène Tetsi Nomigni, Fernand Anton, Ulrike Hanesch

Laboratory of Neurophysiology, Institute for Health and Behavior, University of Luxembourg, 162a, avenue de la Faïencerie, L-1511, Luxembourg, Luxembourg

## ARTICLE INFO

### Keywords:

Early life stress  
Maternal separation  
Neuropathic pain  
Spinal mediators  
Nociceptive transmission

## ABSTRACT

Early life stress (ELS) leads to a permanent reprogramming of biochemical stress response cascades that may also be relevant for the processing of chronic pain states such as neuropathy. Despite clinical evidence, little is known about ELS-related vulnerability for neuropathic pain and the possibly underlying etiology.

In the framework of experimental studies aimed at investigating the respective relationships we used the established ELS model of maternal separation (MS). Rat dams and neonates were separated for 3 h/day from post-natal day 2–12. At adulthood, noxious mechanical and thermal thresholds were assessed before and during induction of neuropathic pain by chronic constriction injury (CCI). The potential involvement of spinal glutamatergic transmission, glial cells, pro-inflammatory cytokines and growth factors was studied by using qPCR.

MS *per se* did not modify pain thresholds. But, when exposed to neuropathic pain, MS rats exhibited a marked reduction of thermal sensitivity and a delayed development of mechanical allodynia/hyperalgesia when compared to control animals. Also, MS did not alter glucocorticoid receptor mRNA levels, but prevented the CCI-induced down-regulation of NR1 and NR2 sub-units of the NMDA receptor and of the glutamate transporter EAAT3 as observed at 21 days post-surgery. Additionally, CCI-provoked up-regulation of glial cell markers was either prevented (GFAP for astrocytes) or dampened (Iba1 for microglia) by MS. Pro-inflammatory cytokine mRNA expression was either not affected (IL-6) or reduced (IL-1 $\beta$ ) by MS shortly after CCI. The growth factors GDNF and NGF were only slightly downregulated 4 days after CCI in the MS-treated animals. The changes in glutamatergic signaling, astroglial and cytokine activation as well as neurotrophin expression could, to some extent, explain these changes in pain behavior. Taken together, the results obtained in the described experimental conditions support the mismatch theory of chronic stress where an early life stress, rather than predisposing individuals to certain pathologies, renders them resilient.

## 1. Introduction

The nervous and the immune system are involved in the stress response as well as in the processing of pain (Krishnan and Nestler, 2008; Schwaller and Fitzgerald, 2014). Stress-related structural or functional modifications within these systems are hence likely to impact pain sensitivity (Sandkühler, 2009). Early life is a critical period for the normal development of individuals. Preclinical (Schmidt, 2010) and clinical (Heim et al., 2010) studies have demonstrated that early life stress can have a major impact on neuronal circuits and immune system development, possibly leading to enhanced vulnerability to physio- and psychopathological states at adulthood. A well-established way of modelling early life stress in rodents is to expose new-born pups to maternal separation (MS) (Levine, 2001). MS has been shown to induce abnormal development of immune and nervous systems (Roque et al., 2015). Among these perturbations is a long term modification of the

central neuronal circuitry involved in relaying noxious stimuli and in controlling pain sensitivity during normal and pathological states (Chung et al., 2007; Uhelski and Fuchs, 2010; Weaver et al., 2007). Neuropathic pain is a chronic pain state that generally occurs following nerve damage. As a consequence, significant peripheral and central remodeling leads to enhanced pain sensitivity (hyperalgesia), induction of pain by a normally non painful stimulus (allodynia) and to spontaneous pain (for review see: von Hehn et al., 2012). Despite significant advances in basic and clinical research, this condition remains difficult to treat since our understanding of the underlying pathophysiological mechanisms is still insufficient (von Hehn et al., 2012).

Although spinal synaptic transmission of noxious stimuli constitutes the first relay of this network, it has scarcely been studied in the context of stress. Among the molecular mediators involved in nociceptive transmission and in the establishment of neuropathic pain, several key players such as the glucocorticoid receptor (GR) (Ladd et al., 2004;

\* Corresponding author.

E-mail address: [julien.genty@uni.lu](mailto:julien.genty@uni.lu) (J. Genty).

Wang et al., 2005), glutamatergic receptors and transporters (Toya et al., 2014), cytokines (Alvarez et al., 2013) and neurotrophins (Faure et al., 2007) are modulated by MS. Thus, it seems plausible that MS could have an impact on neuropathic pain vulnerability at least in a subset of individuals. In addition changes of neuro-immune and/or neuroendocrine systems induced by chronic stress could facilitate or hamper the development of chronic pain independently of classical stress processing pathways. To our knowledge, no study has investigated the effect of MS on pain thresholds and potential spinal molecular mediators involved in the change of nociceptive transmission under conditions of neuropathy. In the present work we used behavioral (mechanical and thermal thresholds) and biochemical (mRNA expression of spinal markers) approaches to assess the impact of MS on the onset and the maintenance of neuropathic pain. In order to induce this pain condition, we decided to use the well-established chronic constriction injury (CCI) model initially described by Bennett and Xie (1988).

## 2. Material and methods

### 2.1. Animals

Female (nulliparous) and male Sprague Dawley rats were purchased from Harlan Laboratories (Netherlands). They were then reared in our facility to provide the offspring used for the experimental studies. All animals were housed under standardized conditions: temperature controlled room (21–23 °C), relative humidity 60 ± 10%, 12 h light/dark cycle, food and water provided *ad libitum*. Rats were only briefly handled twice per week during the cage changes. Except for the maternal separation procedure in the respective groups, pups were left undisturbed until weaning at post-natal day 21. Experiments started when the animals reached the age of 8 weeks.

Animals were divided in 4 groups (see Fig. 1) depending on the stress and pain conditions they were exposed to: controls CON (no MS, no CCI; n = 10), CON+CCI (no MS but CCI; n = 15), MS (MS but no CCI; n = 15), and MS+CCI (MS and CCI; n = 14).

All animal experiments were carried out in accordance with the Directive 2010/63/EU of the European Parliament and of the Council of 22 September 2010 on the protection of animals used for scientific purposes and met the ARRIVE guidelines. The animal procedures were approved by the Animal Experimentation Ethics Committee (AEEC) of the University of Luxembourg (Project ID 15-SPM-01-UH) and the “Ministère de l’Agriculture, de la Viticulture et de la Protection des consommateurs”.

### 2.2. Maternal separation (MS)

Maternal separation was carried out on at least four different litters. The day pups were first seen was marked as P0. From P2 to P12 pups were separated from the dam, placed on a heated pad at 33 °C (± 2 °C) and left undisturbed for 3 h/day. At the end of each separation period pups were returned to their home cage. No other manipulation was done than indicated.

### 2.3. Chronic constriction injury (CCI) surgery

At two months of age, after baseline behavioral testing, rats underwent the CCI surgery. They were deeply anesthetized with isoflurane (4.5% for induction, 2.0–2.2% for maintenance) during the entire procedure using an anesthesia apparatus (Univentor 400, Zejtun, Malta). The right sciatic nerve was exposed in the mid-thigh and three natural chromic gut 4-0 (Stoelting Europe, Dublin, Ireland) loose ligatures were placed around the nerve at a distance of 1 mm. The muscle layer was closed with 4-0 silk sutures and the skin layer with surgical skin staples.

In case animals presented signs of autotomy in the course of the

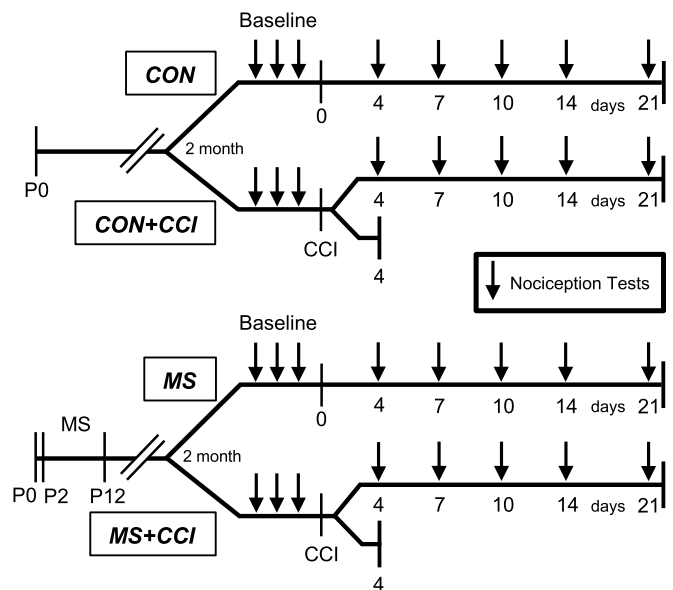

Fig. 1. Experimental design. After birth (P0), rats were separated into 2 experimental groups. The first one was left undisturbed while the second underwent the maternal separation (MS) procedure from postnatal day 2 (P2) to P12. At two months of age, the animals in each of the two groups were either assigned to a non-operated group (CON resp. MS) or to a group that underwent chronic constriction injury (CON+CCI resp. MS+CCI). All four groups were then tested for noxious mechanical and cold thresholds three days in a row to assess baseline values. At day 0, CCI was performed in the respective groups (CON+CCI and MS+CCI) and further behavioral tests were performed in all of the animals on days 4, 7, 10, 14 and 21. After the last testing, animals were sacrificed and the L4-L5 segments of the spinal cord were removed for qPCR analysis of biochemical markers. Two additional sets of animals in the CON+CCI and MS+CCI groups were included to study changes in the expression of biochemical markers early after CCI surgery. They did not undergo behavioral tests and were sacrificed 4 days post-CCI.

experiments, they were immediately removed and sacrificed in order to minimize their suffering. For this reason 2 CON+CCI and 3 MS+CCI animals were sacrificed before the end of the neuropathy protocol and their results were discarded.

### 2.4. Behavioral tests

Noxious mechanical and thermal thresholds were assessed in 54 male rats using the von Frey monofilament test and the cold plate test respectively. All behavioral tests were done in the morning between 8:00 and 12:00 a.m. During each session, animals were moved to the experimentation room at least 1 h before the start of the experiments to allow them to habituate to the environment. Rats underwent the von Frey monofilament test, followed by the cold plate test. Baseline thresholds were assessed on three consecutive days prior to the CCI surgery. To assess the impact of maternal separation on neuropathic pain, the pain sensitivity was tested at days 4, 7, 10, 14, and 21 after the CCI surgery.

#### 2.4.1. Von Frey monofilament test

To evaluate mechanical pain thresholds, animals were placed on a metal wire mesh floor, covered by a Plexiglas chamber (19.5 × 19.5 × 14 cm) and given at least 15 min to acclimate, until exploratory activity ceased. Filaments (OptiHair, MarstockNervTest, Germany) were applied perpendicularly on the mid-plantar region of the hind paw and pressure was gradually increased until the deflection point of the filament. Pain thresholds were determined with the ascending and descending method of limits with forces ranging from 8 to 256 mN. The threshold force was defined as the first filament evoking at least a 40% response rate (two withdrawals out of five consecutive applications). Both hind paws were tested three times in an alternative order and the mean results were defined as the respective thresholds.

**Table 1**  
Sequences of primers used in this study.

Name (gene)	Accession	Sequence	Amplicon size (bp)
Actin, beta	NM_031144.3	F: 5' GCT GAG AGG GAA ATC GTG CGT GAC 3' R: 5' GGA GGA AGA GGA TGC GGC AGT GG 3'	96
GR (NR3C1)	NM_012576.2	F: 5' TGG AAA CCT GCT CTG CTT TG 3' R: 5' GAG GAG ACA AAC AGC ATG TG 3'	102
NR1 (GRIN1)	NM_001270608.1	F: 5' GGT TGC GTG GGC AAC ACC AA 3' R: 5' CCG TCC GCA TAC TTA GAA GA 3'	80
NR2a (GRIN2a)	NM_012573.3	F: 5' CAG ATA ACA ATA AGA ACC ACA AG 3' R: 5' AAC ATC GCT ACA GTC CTT 3'	83
NR2b (GRIN2b)	NM_012574.1	F: 5' AGG AAC CAG GCT ACA TCA AAA A 3' R: 5' TAG TGA TCC CAC TGC CAT GTA G 3'	197
EAAT2 (Slc1a2)	NM_017215.2	F: 5' ATG CTC CTC ATT CTC ACA G 3' R: 5' CTA CAT TGA CCG AAG TTC TC 3'	103
EAAT3 (Slc1a1)	NM_013032.3	F: 5' TCA TAG TCG TGC GGA AGA AC 3' R: 5' AGC GGA ATG TAA CTG GAA GG 3'	111
GFAP	NM_017009.2	F: 5' TAC AGG AAA TTG CTG GAG GG 3' R: 5' GAC ACA GAT TTG GTG TCC AG 3'	104
Iba1 (AIF 1)	NM_017196.3	F: 5' AAT GAT GCT GGG CAA GAG AT 3' R: 5' ACC TCC AAT TAG GGC AAC TC 3'	129
IL-1 $\beta$	NM_031512.2	F: 5' AGA GTG TGG ATC CCA AAC AA 3' R: 5' GGA ACT GTG CAG ACT CAA AC 3'	105
IL-6	NM_012589.2	F: 5' CCA GAG TCA TTC AGA GCA ATA C 3' R: 5' CTT CTC CAT TAG GAG AGC AT 3'	116
GDNF	NM_019139.1	F: 5' GTG TTG CTC CAC ACC GCG TCT 3' R: 5' GGT CTT CGG CGG GCG CTT C 3'	73
NGF	NM_001277055.1	F: 5' CAC GGA CAT CAA GGG CAA GGA 3' R: 5' GCT CGG CAC TTG GTC TCA AA 3'	96

Results were then normalized for each animal by computing the ratio of ipsi- to contralateral side expressed in percent. Finally, data for each group were averaged.

#### 2.4.2. Cold plate test

This test was used to assess stress- and pain-related changes in thermal thresholds. To avoid sensitization it was performed at least 30 min after the von Frey test. In order to establish a baseline, rats were placed on the cold plate set at a temperature of 5 °C for maximally three minutes (cut-off time). In each session, this procedure was repeated three times with a ten minute interval. Lifting or licking the paw as well as jumping are commonly considered as behavioral indicators of pain. We selected the number of paw lifts as behavioral parameter for the assessment of thermal thresholds since CCI-induced neuropathy produced pronounced limping and reduced the animal capacity to jump. The mean values of the three cold plate tests were defined as the score of a session.

#### 2.5. Reverse transcription and real-time qPCR

Rats were rapidly killed by decapitation under deep anesthesia (isoflurane 4.5%). Levels L4/L5 of the spinal cord were harvested and divided into ipsilateral-contralateral sides. Total RNA was extracted by the acid guanidium–thiocyanate–phenol–chloroform method using TRIzol<sup>®</sup> reagent (Life Technologies, Halle, Belgium). The aqueous phase containing RNA was collected and precipitated with isopropanol. The RNA pellet was washed with 70% ethanol, air dried, dissolved in Rnase free water (VWR, Leuven, Belgium) and stored at –80 °C until further analysis.

RNA quality was assessed with the Experion system or the Experion Automated Electrophoresis Station (Bio-Rad Laboratories, Nazareth, Belgium) using StdSens chips (Bio-Rad). The RNA quality indicator was between 7 and 9. RNA concentration was measured using the Nanodrop 2000 spectrophotometer quantification system (Isogen Life Sciences, Netherlands). Reverse transcription was performed with the Improm-II reverse transcription kit (Promega, Leiden, Netherlands) to convert 500 ng of total RNA into cDNA with 0.5  $\mu$ g/ml of Oligo dT15 primer by

using a C1000 Touch thermocycler. qPCR experiments were carried out on a CFX 96 real-time system (Bio-Rad, Nazareth, Belgium) with 12.5 ng of cDNA in a final volume of 20  $\mu$ l using PerfeCTa<sup>®</sup> SYBR<sup>®</sup> Green SuperMix (VWR, Leuven, Belgium) containing 2X reaction buffer with optimized concentrations of MgCl<sub>2</sub>, dNTPs, AccuStart Taq Polymerase, SYBR Green I dye, stabilizers as well as forward and reverse primers at 2  $\mu$ M. Primers were designed using Beacon Designer<sup>™</sup> software, tested for sequence specificity using the Basic Local Alignment Search Tool at NCBI and validated on spinal cord (for list of primers used in the study, see Table 1). The following protocol was used: polymerase activation at 95 °C for 3 min, 40 cycles of denaturation at 95 °C for 10 s and annealing at 61 °C for 30 s. Finally, the melting curves were recorded between 65 °C and 95 °C in 0.5 °C intervals. Each qPCR experiment was run in triplicate and no-template controls were added as negative controls. Threshold cycle values (Cq) were used to compute the amount of target gene mRNA in relation to the reference gene mRNA (actin, beta).  $\Delta$ Cq represents the difference between the number of cycles that were necessary to detect the PCR products of the target genes and that of the reference gene.  $\Delta\Delta$ Cq indicates the difference between the  $\Delta$ Cq of the experimental groups (CON + CCI, MS and MS + CCI) and the  $\Delta$ Cq of the control (CON) animals.

The data were expressed as  $2^{-\Delta\Delta Cq}$  and the mean of the right injured side was computed for each group.

#### 2.6. Statistical analysis

Data are presented as mean  $\pm$  SEM. Homogeneity of variance was tested using Levene's test or Shapiro-Wilk test. Statistical analysis for the von Frey and the cold plate experiments was carried out using a two-way (time x group) repeated measures analysis of variance (ANOVA) followed by a Tukey's multiple comparison *post hoc* test to check for differences between groups.

For all gene expression experiments, the ipsilateral spinal cord of CON (no CCI) served as control and the relative expression level was set to 1. The expression levels of the treatment groups CON + CCI 4d, CON + CCI 21d, MS, MS + CCI 4d and MS + CCI 21d were expressed as fold of CON. For statistical analysis, these relative expression levels (fold) were

**Table 2**  
Analysis of variance (ANOVA) - summary of F-values of the behavioral (two-way, repeated measures) and biochemical (two-way) studies.

Two-way repeated measures ANOVA			
	interaction	time	group
Von Frey test	$F_{(15,225)} = 6.84$	$F_{(5,225)} = 13.09$	$F_{(3,45)} = 41.88$
Cold plate test	$F_{(15,225)} = 14.38$	$F_{(5,225)} = 26.09$	$F_{(3,45)} = 33.25$
	$p < 0.0001$ for all values		
Two-way ANOVA			
	interaction	CCI	stress
GR	$F_{(2,37)} = 1.195$ P = 0.3141	$F_{(2,37)} = 26.35$ P < 0.0001	$F_{(1,37)} = 0.4873$ P = 0.4895
NR1	$F_{(2,36)} = 8.798$ P = 0.0008	$F_{(2,36)} = 0.9035$ P = 0.4145	$F_{(1,36)} = 13.78$ P = 0.0007
NR2a	$F_{(2,36)} = 9.486$ P = 0.0005	$F_{(2,36)} = 8.985$ P = 0.0007	$F_{(1,36)} = 17.45$ P = 0.0002
NR2b	$F_{(2,37)} = 1.896$ P = 0.1645	$F_{(2,37)} = 2.397$ P = 0.1050	$F_{(1,37)} = 19.47$ P < 0.0001
EAAT2	$F_{(2,36)} = 0.7511$ P = 0.4791	$F_{(2,36)} = 20.60$ P < 0.0001	$F_{(1,36)} = 5.740$ P = 0.0219
EAAT3	$F_{(2,36)} = 11.14$ P = 0.0002	$F_{(2,36)} = 8.542$ P = 0.0009	$F_{(1,36)} = 44.50$ P < 0.0001
Iba1	$F_{(2,36)} = 1.013$ P = 0.3734	$F_{(2,36)} = 47.00$ P < 0.0001	$F_{(1,36)} = 14.23$ P = 0.0006
GFAP	$F_{(2,36)} = 2.701$ P = 0.0807	$F_{(2,36)} = 6.238$ P = 0.0047	$F_{(1,36)} = 6.033$ P = 0.0190
IL-1 $\beta$	$F_{(2,36)} = 3.310$ P = 0.0479	$F_{(2,36)} = 11.87$ P = 0.0001	$F_{(1,36)} = 5.701$ P = 0.0223
IL-6	$F_{(2,36)} = 3.259$ P = 0.0500	$F_{(2,36)} = 24.10$ P < 0.0001	$F_{(1,36)} = 0.9615$ P = 0.3334
GDNF	$F_{(2,36)} = 4.952$ P = 0.0126	$F_{(2,36)} = 1.895$ P = 0.1651	$F_{(1,36)} = 6.573$ P = 0.0147
NGF	$F_{(2,36)} = 23.18$ P < 0.0001	$F_{(2,36)} = 0.0808$ P = 0.9225	$F_{(1,36)} = 0.02879$ P = 0.8662

compared using a two-way (stress x CCI) ANOVA with Tukey's multiple comparison *post hoc* test.

A summary of the statistical analysis is given in Table 2.

### 3. Results

#### 3.1. Effect of MS and CCI surgery on pain-related behavior

##### 3.1.1. Mechanical pain threshold

Baseline mechanical thresholds were assessed in all four groups before performing CCI-surgery in the respective groups at d0 (Fig. 2A). No significant differences could be found between groups (CON:  $103.27 \pm 5.65$ ; CON+CCI:  $94.68 \pm 4.20$ ; MS:  $99.29 \pm 5.30$ ; MS + CCI:  $96.61 \pm 4.00$ ), indicating that MS *per se* had no effect on mechanical pain threshold. This was true for the entire period of testing in which the MS group did not present any significant differences as compared to CON (d4: CON  $101.94 \pm 5.08$ , MS  $101.18 \pm 5.46$ ; d7: CON  $104.44 \pm 6.34$ , MS  $108.46 \pm 4.91$ ; d10: CON  $100.15 \pm 6.61$ , MS  $96.23 \pm 3.83$ ; d14: CON  $94.48 \pm 6.04$ , MS  $99.96 \pm 2.66$ ; d21: CON  $105.41 \pm 5.98$ , MS  $111.22 \pm 8.32$ ).

As expected, CCI-surgery resulted in a decrease of mechanical thresholds in CON+CCI and MS+CCI groups. In CON+CCI the threshold constantly dropped until d14 and then started to recover on d21 (d4:  $71.12 \pm 10.22$ ; d7:  $46.94 \pm 7.83$ ; d10:  $41.85 \pm 5.82$ ; d14:  $24.32 \pm 2.05$ ; d21:  $42.14 \pm 6.47$ ). When compared to CON this decrease turned out to be significantly different at d4 ( $p < 0.01$ ) and highly significant from d7 on ( $p < 0.001$ ). The reduction of mechanical thresholds observed in MS+CCI animals did not display a parallel time course. Pain thresholds slowly but constantly decreased until the end of the experiment at d21 without showing recovery (d4:

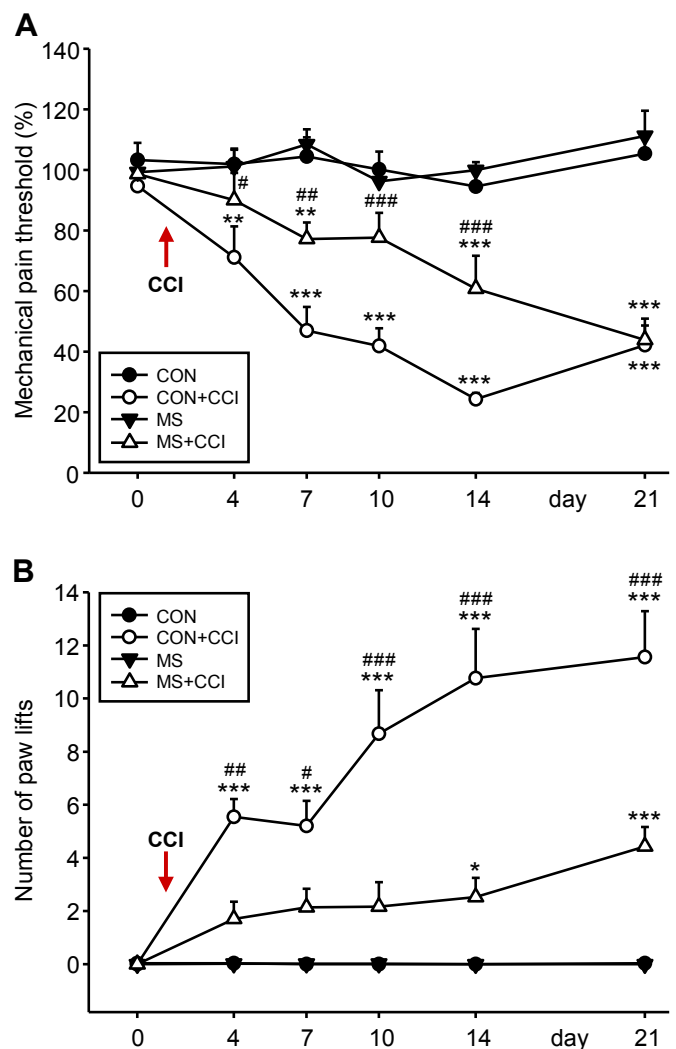

**Fig. 2.** Maternal separation stress reduces CCI-induced mechanical and cold hypersensitivity. (A) Mechanical pain thresholds were measured by the Von Frey test before and during the 21 days of neuropathy and expressed as percent ratio of ipsi- to contralateral side. Before induction of CCI, all four groups presented similar mechanical thresholds. The control (CON, black circles) and the maternally separated group (MS, black triangles) were not subjected to CCI; their mechanical threshold was unchanged in the course of the experiment. In the control group that underwent CCI surgery (CON + CCI, white circles) the mechanical pain threshold decreased until day 14 and started to recover at day 21. The maternally separated group that was subjected to CCI (MS + CCI, white triangles) reacted with a steady decrease of pain thresholds until the end of the experiment. MS + CCI animals were less sensitive than the CON + CCI group for up to 14 days. (B) Thermal pain thresholds were evaluated by using the cold plate test. The number of lifts of the ipsilateral (right) paw was recorded before and up to 21 days after induction of CCI. No paw lifts could be observed in the baseline testing of all four groups before CCI surgery. The two groups, CON (black circles) and MS (black triangles), that were not exposed to neuropathic pain remained insensitive to cold stimuli throughout the testing period. Control animals undergoing CCI surgery (CON + CCI, white circles) rapidly developed a pronounced cold allodynia that steadily increased until the end of the experiment at day 21. Rats with a history of early life stress that were exposed to neuropathic pain (MS + CCI, white triangles), exhibited a slight but insignificant increase in cold sensitivity during the first 10 days of the testing period and exhibited significant cold allodynia only in the late phase of CCI at d14 and d21. Data are expressed as mean  $\pm$  SEM per group per day. \* represents a significant difference between CON and CON + CCI or MS and MS + CCI for the individual time point (\* $p < 0.05$ , \*\* $p < 0.01$ , \*\*\* $p < 0.001$ ). # indicates a significant difference between CON + CCI and MS + CCI (# $p < 0.05$ , ## $p < 0.01$ , ### $p < 0.001$ ).

$93.98 \pm 9.16$ ; d7:  $77.18 \pm 5.44$ ; d10:  $78.21 \pm 7.50$ ; d14:  $59.51 \pm 9.95$ ; d21:  $43.86 \pm 7.04$ ). When comparing to the group only exposed to MS, significant differences were found for all time points (d4:  $p < 0.05$ , d7:  $p < 0.01$ , d14:  $p < 0.001$ , d21:



$p < 0.001$ ).

Animals with a history of maternal separation (MS+CCI) exhibited a clearly higher mechanical threshold after induction of neuropathic pain than rats that were not subjected to this early life stress (CON+CCI). Shortly after CCI surgery at d4, a significant difference ( $p < 0.05$ ) between the two groups could already be seen. From d7 to d14, the difference between groups was pronounced (d7:  $p < 0.01$ ; d10 and d14:  $p < 0.001$ ). At d21 the mechanical thresholds of CON+CCI and MS+CCI groups became comparable again.

Taken together, these results indicate that MS protracts the appearance of mechanical hyperalgesia associated with neuropathy.

### 3.1.2. Thermal pain threshold

As described for the assessment of baseline mechanical thresholds, the thermal sensitivity was measured in the four experimental groups prior to CCI on d0 (Fig. 2B). No significant differences in the number of paw lifts were observed between the groups (CON:  $0.03 \pm 0.02$ , CON+CCI:  $0.00$ , MS:  $0.00$ , MS+CCI:  $0.00$ ). The thermal sensitivity of CON and MS animals remained constantly low throughout the experiment; the two groups did not display any significant differences.

CCI surgery in the CON+CCI and MS+CCI groups resulted in a decrease of nociceptive thermal thresholds. The rise in paw lifts was much more pronounced in the CON+CCI animals and steadily increased throughout the experiment until d21 (d4:  $5.82 \pm 0.66$ , d7:  $5.21 \pm 0.94$ , d10:  $8.68 \pm 1.64$ , d14:  $10.77 \pm 1.85$ , d21:  $11.56 \pm 1.73$ ). The comparison with its control CON yielded a high statistical significance ( $p < 0.001$ ) for all time points. In MS+CCI the number of paw lifts slightly increased after induction of neuropathy (d4:  $1.71 \pm 0.64$ , d7:  $2.14 \pm 0.70$ , d10:  $2.17 \pm 0.92$ ) without gaining statistical significance when comparing to the MS group. From d14 on the thermal sensitivity further increased reaching a significant level (d14:  $2.53 \pm 0.73$ ,  $p < 0.05$ ; d21:  $4.43 \pm 0.74$ ,  $p < 0.001$ ). Rats that underwent early life stress (MS+CCI) developed clearly less thermal hyperalgesia under conditions of neuropathic pain than animals that grow up normally (CON+CCI). This difference could already be seen early after induction of CCI and lasted until the end of the experiment. Statistical tests revealed significances between the two groups of  $p < 0.01$  for d4,  $p < 0.05$  for d7 and  $p < 0.001$  for d10, d14 and d21. Altogether these results suggest that animals that were subjected to MS present reduced and delayed development of thermal hyperalgesia in neuropathic pain states.

## 3.2. Impact of early life stress and neuropathic pain on the expression of spinal biochemical markers

### 3.2.1. Glucocorticoid receptor regulation

CON and MS presented comparable GR mRNA levels ( $1.03 \pm 0.25$  and  $1.16 \pm 0.16$  resp.) (Fig. 3A), suggesting that maternal separation stress *per se* did not affect the expression of the glucocorticoid receptor. The induction of CCI resulted in a significant downregulation of GR mRNA at d4 in CON+CCI ( $0.72 \pm 0.11$ ;  $p < 0.01$  compared to CON) as well as in MS+CCI rats ( $0.72 \pm 0.41$ ;  $p < 0.001$  compared to MS). At a later state of neuropathy, on d21, GR mRNA expression returned to normal levels in the CON+CCI group ( $1.02 \pm 0.85$ ;  $p < 0.001$  to CON+CCI 4d) and in MS+CCI animals ( $0.99 \pm 0.09$ ;  $p < 0.001$  to MS+CCI 4d). The two-way ANOVA revealed significant main effects only for CCI, not for stress or interaction (Table 2).

### 3.2.2. Regulation of glutamate receptors and transporters

In comparison to CON, MS *per se* significantly increased the mRNA expression of all three examined subunits of the NMDA receptor, NR1 (CON:  $1.01 \pm 0.07$ , MS:  $1.60 \pm 0.06$ ;  $p < 0.05$ ), NR2a (CON:  $1.01 \pm 0.09$ , MS:  $1.65 \pm 0.05$ ;  $p < 0.001$ ) and NR2b (CON:  $1.07 \pm 0.15$ , MS:  $1.54 \pm 0.06$ ;  $p < 0.01$ ) (Fig. 3B, 3C, 3D).

In the initial post-surgical phase, at d4, CCI had no influence on the mRNA levels of NR1 ( $1.12 \pm 0.08$ ), NR2a ( $1.08 \pm 0.6$ ) and NR2b

( $0.99 \pm 0.1$ ) in CON+CCI rats. In contrast, MS+CCI animals reacted with a significant decrease of NR1 ( $1.07 \pm 0.11$ ;  $p < 0.05$  to MS) and NR2a ( $0.94 \pm 0.07$ ;  $p < 0.001$  to MS) mRNA levels and a clear tendency to reduced mRNA expression in NR2b ( $1.15 \pm 0.17$ ) at this time point, now being comparable to CON+CCI.

At post-CCI day 21, animals from the CON+CCI group presented a trend to reduced NR1 ( $0.78 \pm 0.05$ ; n.s. to CON, but  $p < 0.01$  to CON+CCI 4d) and significantly decreased NR2a levels ( $0.74 \pm 0.06$ ;  $p < 0.05$  to CON), but no significant change in NR2b ( $0.86 \pm 0.05$ ) mRNA expression.

In MS+CCI animals a tendency to recover could be observed on d21. The mRNA levels of all three subunits increased slightly (NR1:  $1.24 \pm 0.17$ , NR2a:  $1.19 \pm 0.21$ , NR2b:  $1.43 \pm 0.15$ ), returning nearly to basal values, except for NR2a which was still significant different from MS ( $p < 0.05$ ). Nevertheless, for NR1, NR2a and NR2b a significant difference ( $p < 0.01$ ,  $p < 0.05$  and  $p < 0.01$  resp.) to the CON+CCI group could be assessed. Generally, significant main effects were revealed for stress (NR1, NR2a, NR2b), CCI (NR2a) and interaction (NR1, NR2a) (Table 2).

EAAT2 mRNA levels did not significantly differ between non-injured CON and MS animals (CON:  $1.02 \pm 0.1$ ; MS:  $0.93 \pm 0.48$ ) (Fig. 3E). Post-CCI, at d4, CON+CCI and MS+CCI groups presented a similar and significant reduction of EAAT2 mRNA levels when compared to the respective controls (CON+CCI:  $0.67 \pm 0.03$ ,  $p < 0.001$  to CON; MS+CCI:  $0.63 \pm 0.04$ ,  $p < 0.01$  to MS). In the later phase of the neuropathic state, at d21, EAAT2 mRNA levels of CON+CCI returned approximately to basal values ( $0.89 \pm 0.05$ ), thus being no longer significantly different from CON, but remaining different from CON+CCI at d4 ( $p < 0.001$ ). In the same line the EAAT2 mRNA expression in MS+CCI animals slightly increased at d21 ( $0.73 \pm 0.05$ ), leading also to a loss of significant difference to MS.

Regarding EAAT3, early life stress had a clear impact on the mRNA expression (Fig. 3F). The mRNA level increased to  $1.38 \pm 0.01$  in MS and was hence significantly higher than seen in CON ( $1.00 \pm 0.03$ ;  $p < 0.001$ ). Induction of neuropathic pain had no effect on the CON+CCI group at d4 ( $1.13 \pm 0.06$ ), but led to a significant decrease of EAAT3 mRNA levels in the maternally separated animals MS+CCI ( $1.13 \pm 0.06$ ;  $p < 0.01$  to MS), that now were similar to CON+CCI. At d21 post-surgery the EAAT3 mRNA level dropped in the CON+CCI group ( $0.8 \pm 0.05$ ; n.s. to CON but  $p < 0.001$  to CON+CCI 4d), whereas the level slightly increased in the MS+CCI animals ( $1.20 \pm 0.06$ ), thus being no longer significantly different from MS. The small downregulation in CON+CCI 21d and the minor upregulation in MS+CCI 21d finally resulted in a highly significant difference between these two groups ( $p < 0.001$ ). Significant main effects were obtained for stress (EAAT2, EAAT3), CCI (EAAT2, EAAT3) and interaction (EAAT3) (Table 2).

### 3.2.3. Glial cell activation

The expression of Iba1 (ionized calcium-binding adaptor protein-1) mRNA in microglia was affected by early life stress (Fig. 4A). The MS group exhibited a significantly reduced mRNA level ( $0.74 \pm 0.01$ ) as compared to CON ( $1.00 \pm 0.05$ ;  $p < 0.05$ ). Shortly after CCI surgery, the Iba1 mRNA expression significantly increased in the CON+CCI ( $2.69 \pm 0.08$ ;  $p < 0.001$  to CON) as well as in the MS+CCI group ( $1.84 \pm 0.14$ ;  $p < 0.001$  to MS). The difference between the two groups did stay statistically significant ( $p < 0.05$ ), as seen between CON and MS. At the early chronification phase of neuropathic pain (d21), the Iba1 mRNA level decreased in the CON+CCI group ( $1.84 \pm 0.03$ ;  $p < 0.001$  to CON+CCI 4d) and was still significantly different from the basal level in CON ( $p < 0.01$ ). The expression in the MS+CCI group, did however not change as compared to d4 and hence remained significantly different from the non-injured MS ( $p < 0.01$ ). At this time point the difference between CON+CCI and MS+CCI became smaller and lost significance. In summary, maternal separation stress led to a decrease of microglia activation under normal conditions

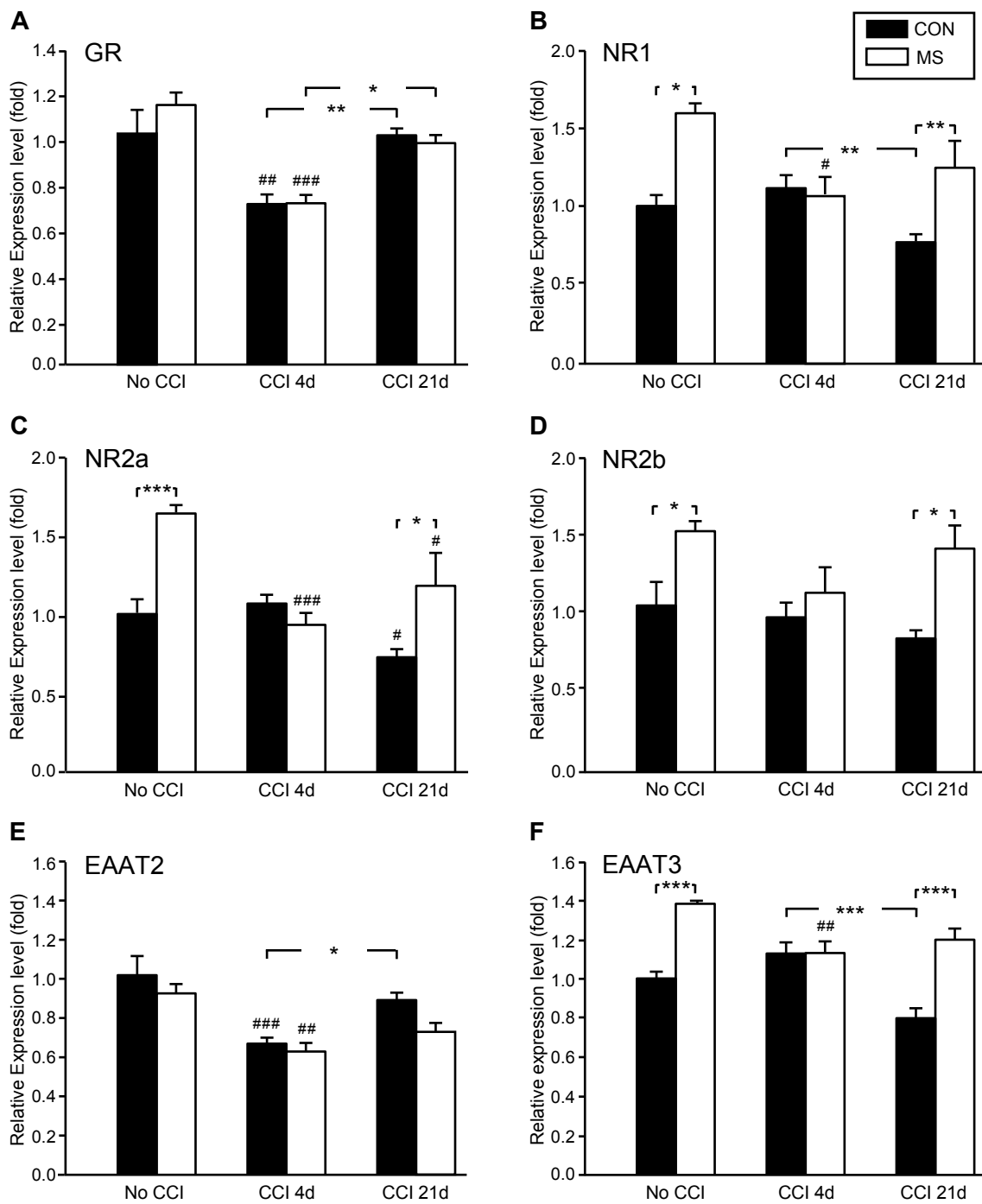
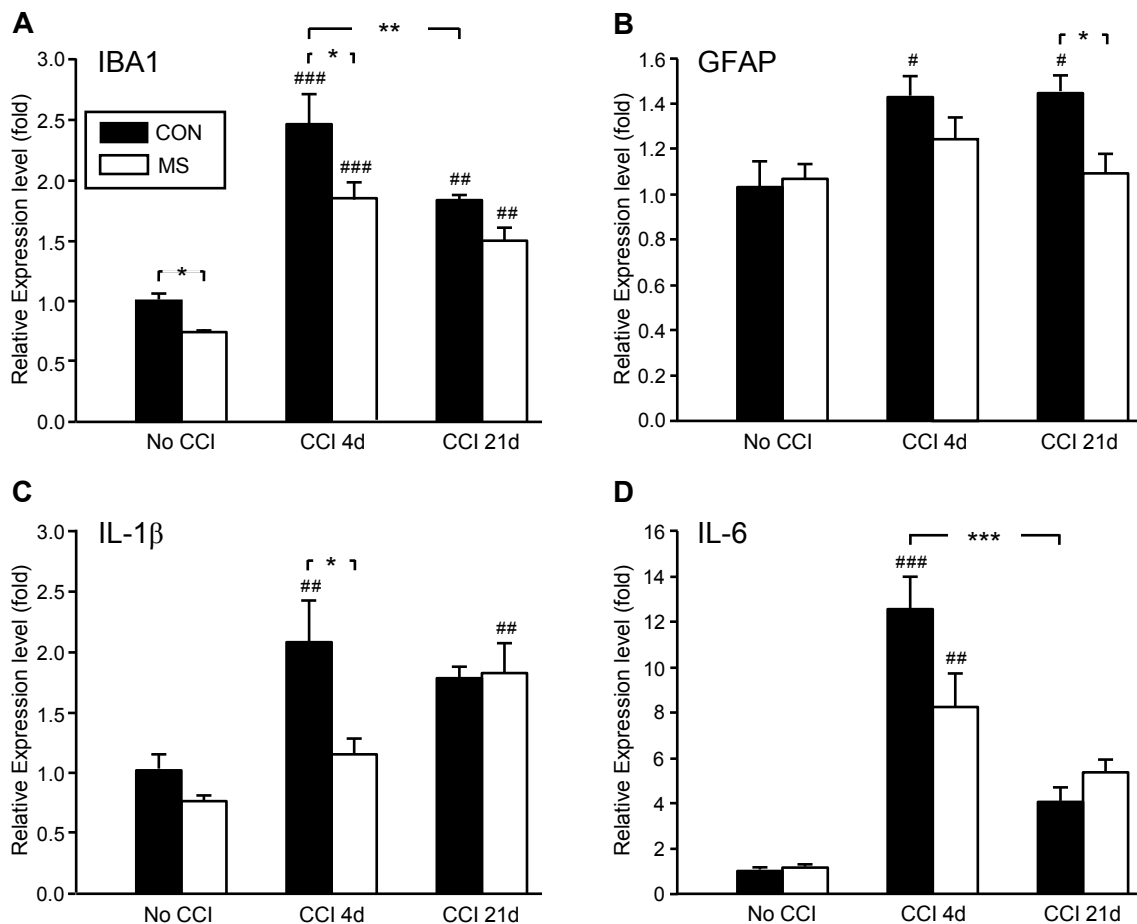

**Fig. 3.** Regulation of actors of spinal glutamatergic synapse function. Gene expression in the spinal cord was examined for the glucocorticoid receptor (GR) (A), the NMDA receptor subunits NR1 (B), NR2a (C), NR2b (D) and the glutamate transporters EAAT2 (E) and EAAT3 (F). Mean mRNA levels were assessed in control (CON, black bars) and maternally separated animals (MS, white bars) under three different conditions: without CCI surgery (no CCI), CCI lasting four days (CCI 4d) and CCI lasting 21 days (CCI 21d). (A) GR expression did not differ between CON and MS animals in the three conditions. GR mRNA was downregulated at 4 days after induction of CCI and recovered in the late phase at 21 days. (B–D) The three NMDA receptor subunits followed a similar regulation scheme: mRNA upregulation in MS animals *per se*, downregulation in MS 4 days after CCI but no change in CON, and slight reduction in CON after 21 days of CCI when MS started to recover. (E, F) The regulation of mRNA expression was different in the glial EAAT2 and the neuronal EAAT3 transporter. The level of EAAT2 mRNA did not differ between CON and MS under the three different conditions CCI surgery downregulated EAAT2 mRNA at 4d followed by a recovery trend at 21d. The regulation of EAAT3 mRNA resembles the scheme seen for the NMDA subunits: upregulation in MS *per se*, downregulation in MS 4 days after CCI but no change in CON, and slight recovery in MS but downregulation in CON after 21 days of CCI. Data are expressed as relative expression level (fold) of “CON, no CCI” (=1) and are shown as mean ± SEM. # represents a significant difference between “CON, no CCI” and “CON+CCI 4d” or “CON+CCI 21d” or between “MS, no CCI” and “MS+CCI 4d” or “MS+CCI 21d” (#p < 0.05, ##p < 0.01, ###p < 0.001). \* indicates a significant difference between groups for other comparisons than the ones covered by # (\*p < 0.05, \*\*p < 0.01, \*\*\*p < 0.001).

(no neuropathy) and to a reduced upregulation of Iba1 mRNA under CCI conditions.

In contrast to the upregulation of the microglia marker Iba1 observed in animals subjected to early life stress, MS *per se* had no impact

on the mRNA expression of the astrocytic marker GFAP (glial fibrillary acidic protein) (CON: 1.03 ± 0.11, MS: 1.07 ± 0.06) (Fig. 4B). CCI led to a statistically significant upregulation of GFAP mRNA in CON + CCI at d4 post-surgery (1.43 ± 0.08; p < 0.05 to CON), but not in



**Fig. 4.** Regulation of markers of spinal immunocompetent cell activation and of pro-inflammatory cytokines. Gene expression in the spinal cord was examined for the microglial marker Iba1 (A), the astroglial marker GFAP (B) and the pro-inflammatory cytokines IL-1β (C) and IL-6 (D). Mean mRNA levels were assessed in control (CON, black bars) and maternally separated animals (MS, white bars) under three different conditions: without CCI surgery (no CCI), CCI lasting four days (CCI 4d) and CCI lasting 21 days (CCI 21d). (A) Iba1 mRNA levels were downregulated in MS as compared to CON. Induction of CCI upregulated the gene expression at 4d in both groups, the significant difference between groups remained. A beginning recovery could be observed at d21 in CON and a tendency to recover in MS. (B) GFAP mRNA levels did not differ between “CON, no CCI” and “MS, no CCI”. Neuropathy surgery upregulated the gene expression only in “CON + CCI 4d and 21d” but not in MS. (C) IL-1β mRNA expression tended to be lower in “MS, no CCI” as compared to “CON, no CCI”. After induction of CCI at d4, IL-1β was quickly upregulated in CON and started to increase in MS. Later, at day 21, the IL-1β mRNA level already decreased in CON whereas it further increased in MS. (D) IL-6 mRNA levels did not significantly differ between CON and MS in all three conditions. The gene expression was highly upregulated in CON and MS 4 days after CCI surgery. Under long-term neuropathy conditions, mRNA levels decreased coming close to normal expression rates. Data are expressed as relative expression level (fold) of “CON, no CCI” (= 1) and are shown as mean ± SEM. # represents a significant difference between “CON, no CCI” and “CON + CCI 4d” or “CON + CCI 21d” or between “MS, no CCI” and “MS + CCI 4d” or “MS + CCI 21d” (#p < 0.05, ##p < 0.01, ###p < 0.001). \* indicates a significant difference between groups for other comparisons than the ones covered by # (\*p < 0.05, \*\*p < 0.01, \*\*\*p < 0.001).

the MS + CCI group (1.24 ± 0.9). Nevertheless, the difference between the CON + CCI and the MS + CCI groups did not reach statistical significance in the early phase of neuropathy. Later on, at d21, the GFAP mRNA stayed upregulated in the CON + CCI animals (1.44 ± 0.07; p < 0.05 to CON) and the MS + CCI group remained unaffected by the surgery (1.09 ± 0.08). In this state, a significant difference between the two groups could be observed (p < 0.05). Taken together, MS prevented the upregulation of GFAP mRNA triggered by CCI. The two-way ANOVA revealed significant main effects for stress and CCI for Iba1 as well as for GFAP (Table 2).

### 3.2.4. Regulation of pro-inflammatory cytokines

The IL-1β mRNA expression was slightly, but not significantly reduced in MS *per se* (CON: 1.02 ± 0.12, MS: 0.77 ± 0.04) (Fig. 4C). On post-CCI day 4, IL-1β mRNA was clearly upregulated in CON + CCI (2.69 ± 0.82; p < 0.01 to CON) but only a tendency to higher levels was observed in MS + CCI animals (1.15 ± 0.13), leading to a significant difference between the two groups (p < 0.05). The IL-1β mRNA level started to decrease in CON + CCI animals at d21 after CCI surgery (1.79 ± 0.08; n.s. to CON and n.s. to CON + CCI 4d) but

further increased in MS + CCI (1.83 ± 0.25; p < 0.01 to MS), resulting in the loss of a significant difference between the CON + CCI and MS + CCI group. The data do hence suggest that the early life stress tended to decrease the expression of IL-1β under normal conditions, and particularly delayed the upregulation seen in neuropathic states. Statistical significant main effects were obtained for stress, CCI and interaction (Table 2).

Regarding the IL-6 mRNA expression, no difference was found between CON (1.01 ± 0.9) and MS (1.17 ± 0.09). Four days after induction of CCI the IL-6 mRNA level increased considerably in CON + CCI (12.59 ± 1.44; p < 0.001 to CON) and in MS + CCI (8.28 ± 1.50; p < 0.01 to MS). Although the CON + CCI and MS + CCI groups respectively presented a 12 fold and an 8 fold increase of IL-6 mRNA levels, this difference did not turn out to be statistically significant due to high levels of variance in the two groups. In the later phase of the experiment, at d21, the IL-6 mRNA levels decreased significantly for CON + CCI (4.08 ± 0.59; p < 0.001 to CON + CCI 4d) and also dropped in MS + CCI (5.98 ± 0.55) being no longer significantly different from CON resp. MS. The statistical analysis revealed that animals with a history of maternal separation did not display any

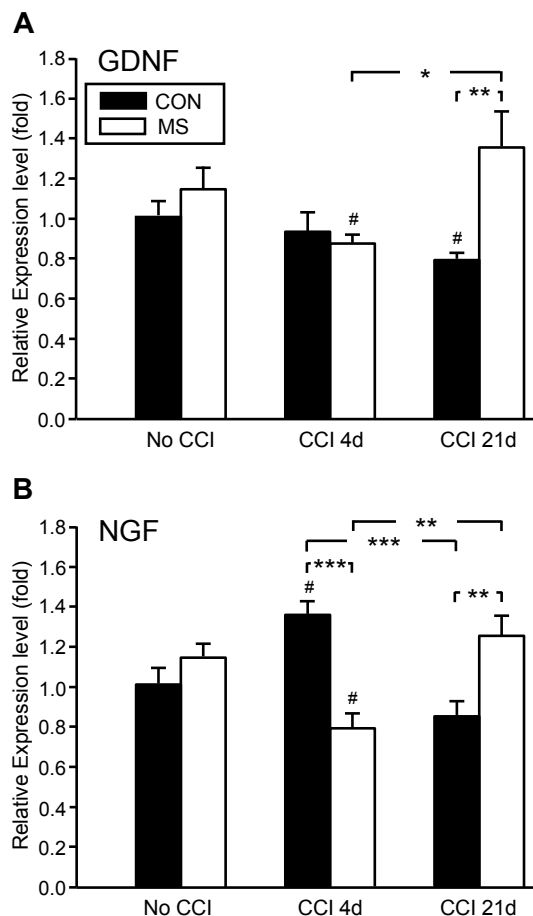

**Fig. 5.** Regulation of spinal neurotrophins. Spinal gene expression was examined for the neurotrophins GDNF (A) and NGF (B). Mean mRNA levels were assessed in control (CON, black bars) and maternally separated animals (MS, white bars) under three different conditions: without CCI surgery (no CCI), CCI lasting four days (CCI 4d) and CCI lasting 21 days (CCI 21d). (A) GDNF mRNA expression did not differ between CON and MS under the conditions of no CCI and CCI 4d. In the long-term CCI condition, GDNF mRNA level differed between CON and MS, due to an upregulation in MS animals. (B) NGF mRNA levels were not different in “CON, no CCI” and “MS, no CCI” animals. The induction of CCI triggered an increase in CON and a decrease in MS 4 days post-surgery. At d21, a recovery occurred, which partly overshoot and consequently resulted in a difference in mRNA expression between CON and MS. Data are expressed as relative expression level (fold) of “CON, no CCI” (=1) and are shown as mean  $\pm$  SEM. # represents a significant difference between “CON, no CCI” and “CON + CCI 4d” or “CON + CCI 21d” or between “MS, no CCI” and “MS + CCI 4d” or “MS + CCI 21d” ( $^{\#}p < 0.05$ ,  $^{\#\#}p < 0.01$ ). \* indicates a significant difference between groups for other comparisons than the ones covered by # (\*\* $p < 0.01$ , \*\*\* $p < 0.001$ ).

differences in IL-6 mRNA levels as compared to the respective controls. A significant main effect was only found for CCI (Table 2).

### 3.2.5. Expression of neurotrophins

MS *per se* did not modify GDNF mRNA levels (CON:  $1.01 \pm 0.07$ , MS  $1.15 \pm 0.11$ ) (Fig. 5A). The induction of neuropathic pain had no significant influence on the expression of GDNF mRNA in CON + CCI animals ( $0.94 \pm 0.10$ ) early after surgery at d4, however a reduction could be observed in MS + CCI ( $0.88 \pm 0.04$ ;  $p < 0.05$  to MS). After 21 days of injury, a significant decrease of the GDNF mRNA level took place in the CON + CCI group ( $0.79 \pm 0.03$ ;  $p < 0.05$  to CON), whereas animals with a history of early life stress reacted with an increase of this neurotrophin mRNA ( $1.20 \pm 0.10$ ;  $p < 0.01$  to MS + CCI 4d) at this time point, ending up with an mRNA level numerically above but not significantly different to MS. However, in this late phase of neuropathy, a significant difference was obtained when comparing CON + CCI and MS + CCI ( $p < 0.01$ ). Statistically significant main

effects were obtained for stress and interaction (Table 2).

The baseline NGF gene expression was comparable between the CON ( $1.15 \pm 0.62$ ) and MS ( $1.01 \pm 0.08$ ) group (Fig. 5B). Four days following CCI surgery, NGF mRNA levels increased in CON + CCI ( $1.36 \pm 0.06$ ;  $p < 0.05$  to CON) and decreased in MS + CCI ( $0.79 \pm 0.07$ ,  $p < 0.05$  to MS) resulting in a highly significant difference between the two groups ( $p < 0.001$ ). After 21 days, both groups roughly returned to control levels (CON + CCI:  $0.85 \pm 0.07$ ;  $p < 0.001$  to CON + CCI 4d; MS + CCI:  $1.26 \pm 0.10$ ,  $p < 0.01$  to MS + CCI 4d) but remained significantly different from each other ( $p < 0.01$ ). A significant main effect was obtained for interaction (Table 2).

## 4. Discussion

The present study shows that early life stress related to MS in rodents does not affect basal thermal and mechanical nociceptive thresholds *per se* but has a protective effect on both modalities under neuropathic conditions. This behavioral change was accompanied by molecular alterations in the spinal cord. To our knowledge the impact of MS on mediators involved in the spinal processing of neuropathic pain has not been studied so far.

### 4.1. Maternal separation reduces CCI-induced hyperalgesia/allodynia

In humans, adverse early life events are associated with enhanced risks of developing mental or physical health problems including chronic pain disorders later in life (Heim et al., 2010; Heim and Binder, 2012; Lupien et al., 2009). This has been shown to be related to a permanent alteration of the hypothalamo-pituitary-adrenal (HPA) axis (Sapolsky and Meaney, 1986), as well as of neural (Lippmann et al., 2007; Mintz et al., 2005; Rana et al., 2014) and immune functioning (Bilbo and Schwarz, 2009; Carpenter et al., 2010; Wieck et al., 2013). In rodents, normal development during the critically vulnerable stress hyporesponsive period (SHRP) in the first two post-natal weeks essentially depends on maternal care (Caldji et al., 1998). Disruption by prolonged and/or repeated sequences of MS leads to alterations comparable to those observed in humans (Schmidt, 2010). Furthermore, the first week of the rodent's life corresponds developmentally to the third trimester of human gestation (Lupien et al., 2009) making MS an adequate model for the stress premature infants are exposed to.

In rats, early life stress has been associated with an attenuation of drug-induced analgesic effects (Dickinson et al., 2009; Kalinichev et al., 2001), increased pain sensitivity in normal conditions (Alvarez et al., 2013; Green et al., 2011) but also in the framework of several experimental and clinical pain states such as chronic bowel syndrome (O'Mahony et al., 2009), visceral hyperalgesia (Chung et al., 2007; Tsang et al., 2012) and neuropathic pain (Zeng et al., 2008). While rats undergoing early life stress have mostly been reported to present increased nociceptive responses to mechanical and/or thermal nociceptive stimulation (Chung et al., 2007; Tsang et al., 2012; Uhelski and Fuchs, 2010), we did not observe any change in basal nociceptive thresholds, but a reduced CCI-induced hypersensitivity for both modalities. It should be noted here that MS does not in every case lead to the development of psychiatric diseases (Rana et al., 2014) or enhanced pain sensitivity (Weaver et al., 2007) later in life. Resilience, an adaptive process allowing physiological (homeostatic) and behavioral adaptation to stress, has also been observed in rodent models of early life stress such as MS (Macri et al., 2011). Pfau et Russo (2015) propose that the resilience observed in rodents undergoing early life stress follows a U-shaped curve. Exposure to a medium amount of stress could hence lead to resilience while very low or very high levels would lead to vulnerability. It should be noted here that the term “resilience” is generally considered to represent a positive adaptation of stress processing to a context specific stressor while “vulnerability” is commonly used to describe stress-related alterations in susceptibility to health



disorders like chronic pain syndromes later in life (Alvarez et al., 2013). The fact that early life stress leads to alterations of brain structures is involved both in stress and in pain processing (Prusator and Greenwood-Van Meerveld, 2016) may impede a clear differentiation between these two terms. Hence, we suggest that MS could lead to a form of resilience to CCI-induced hypersensitivity independently to its effects on vulnerability or resilience to further stress processing.

Furthermore, differences in methodology across studies such as rearing of the dams could lead to differences in experimental outcomes. Transportation from the animal supplier to the client is a routine practice but the stress induced by the shipping is rarely considered. Despite the few studies investigating the implications of the shipping in stress paradigms, increased blood corticosterone levels, decrease of social behavior and locomotor activity up to 16 days after transportation have been observed (Arts et al., 2012). These results suggest that shipping can have long lasting physiological and behavioral effects. This would especially be true for developmental and high plasticity periods such as gestation (Lupien et al., 2009; Weinstock, 2008). Nevertheless, several studies showing an increased sensitivity following early life stress were performed in the offspring of females that were pregnant at the time point of shipment (Alvarez et al., 2013; Chung et al., 2007; Green et al., 2011; Kalinichev et al., 2001; Nishinaka et al., 2016; Tsang et al., 2012). The animals to be tested could hence have accumulated pre- and post-natal stress. Variations in experimental outcomes could thus at least partly be related to our rearing the dams in our facility.

#### 4.2. MS alters spinal glutamatergic transmission and transport

The glucocorticoid receptor (GR) is a key regulator of the amplitude of the HPA response to stressors (Strüber et al., 2014) and of neuropathy-induced plastic changes (Wang et al., 2004, 2005, 2006). In the present study we observed that spinal GR expression was not different between CON and MS groups, neither under basal conditions, nor shortly (4d) and later (21d) after the CCI surgery. There is a paucity of studies investigating the impact of circulating corticosterone on spinal GR expression and to our knowledge no study has explored the impact of chronic stress on spinal GR expression. However, Patacchioli et al. (1998) showed no effect of 21 days of corticosterone treatment on spinal GR mRNA. Therefore, it is difficult to establish a parallel between our spinal GR mRNA results and a hypothetical HPA axis alteration by MS. In our hands only CCI had an impact on GR mRNA expression levels. Indeed, CON and MS groups presented a decrease of GR expression 4 days after CCI and recovered after 21 days. CCI-induced reduction of GR expression was not expected since Wang and collaborators (2004, 2005, 2006) reported that CCI induced a time-dependent increase of GR protein and mRNA expression parallel to the development of painful behaviors. The pattern of expression found in CON and MS animals following CCI could be due to injury-related pain and distress, where the resulting hypothetical increase of corticosteroid concentration might have been compensated by a decrease of GR expression. Subsequently, as the animals recovered from the injury, the GR mRNA expression returned to levels comparable to those of non-injured rats. The finding that only MS rats displayed a strong increase of neuropathy-related pain thresholds while both CON and MS animals presented similar reduction of GR expression during the CCI phase may point to an alternative CORT-dependent mechanism of pain inhibition potentially emerging in the MS animals. In these rats, the production of spinal neurosteroids might have enhanced GABAergic and hence inhibitory transmission (Zell et al., 2015).

Since corticosterone may regulate glutamate receptors (Wang et al., 2005) and transporters (Wang et al., 2006) through GR activation under neuropathic pain conditions we investigated NMDA receptor and transporter subunit mRNA expression levels.

Experimental neuropathic pain models resulted in enhanced NR1 and NR2 expression levels ipsilateral to injury (Abe et al., 2005; Wang

et al., 2005). We report a differential effect of CCI on animals that underwent MS as compared to CON. Although these results are not directly indicative of spinal nociceptive transmission, the functional properties of the NMDA receptor depend on patterns of subunit associations reflecting enduring plastic changes in synaptic efficacy. The association of NR1 and NR2a subunits does e.g. provide a higher opening probability, a reduced sensitivity to glutamate and a faster decay of excitatory postsynaptic current (EPSC) than the NR1/NR2b NMDA subunit association (Paoletti et al., 2013). This association has been proposed to be, at least to some extent, responsible for the central sensitization involved in the development of neuropathic pain (Wilson et al., 2005; Wu and Zhuo, 2009). In adult male Wistar rats, a decay of NR1 protein has previously been reported by Wilson et al. (2005) 16 days after CCI. In that study, the authors did not report a decrease of NR2a but we cannot exclude the possibility that the decrease we observed at post-CCI day 21 occurred after the 16th day post-CCI. Whereas several studies suggest a primordial role of NR2b in the establishment and maintenance of neuropathic pain (Karlsson et al., 2002; Wilson et al., 2005; Wu and Zhuo, 2009) we did not observe any drastic change in the NR2a/NR2b ratio following CCI. MS animals presented a general augmentation of all three NMDA receptor subunit mRNA levels that would suggest an enhanced nociceptive transmission and a resulting decrease of pain thresholds. Shortly after the CCI surgery, NR1 and NR2a subunit mRNA expression seemed to decrease to a larger extent than NR2b mRNA. This would suggest a change of NMDA subunit proportions toward more NR1/NR2b association in MS animals. Furthermore, 21 days after CCI NR1 and NR2b subunits expression recovered to MS basal levels. The observation that MS + CCI rats seemed to display a greater NR1/NR2b subunit association than CON + CCI might indicate a mechanism underlying delayed development of neuropathic allodynia/hyperalgesia in MS animals when compared to CON.

Neuronal (EAAT3) and glial (EAAT2) glutamate transporters are involved in nociceptive processing in healthy individuals since injection of blockers elicits a dose-dependent spontaneous nociceptive behavior (Liaw et al., 2005), but also in neuropathic animals since their protein and mRNA expression are modified following CCI (Sung et al., 2003; Wang et al., 2006). In the present study, MS animals presented higher mRNA levels of EAAT3, but not EAAT2, suggesting an increased glutamate re-uptake in MS and therefore a reduced spinal transmission of noxious information. In association with the increase of NMDA receptor subunit expression, this result could explain the lack of difference in nociceptive thresholds between MS and CON animals. In CON, CCI tended to decrease the EAAT3 mRNA expression 21 days after surgery. A reduction of EAAT3 expression was also reported by Sung et al. (2003) who proposed that this was due to a loss of primary afferents resulting from the CCI, considering that most of glutamate transporters are located at presynaptic sites (Danbolt, 2001).

Concerning EAAT2, we and other investigators observed a decreased expression at 4 but not 21 days after CCI in CON animals (Napier et al., 2012; Xin et al., 2009). It is probable that this recovery was due to a compensatory mechanism aimed at re-establishing a “normal” re-uptake of glutamate by glial cells. Furthermore, since glial glutamate transporters are believed to account for 90% of glutamate clearance in the CNS (Danbolt, 2001), this result could be in line with the initiation of a possible recovery of a normal sensitivity observed at post-CCI day 21 in CON animals. In agreement with Gosselin et al. (2010), MS did not impact the EAAT2 expression in non-injured conditions. Likewise EAAT2 mRNA expression followed a comparable pattern in MS and CON animals 4 and 21 days after CCI. This lack of group differences suggests that the EAAT2 glutamate transporter does not considerably contribute to CCI-related alterations in mechanical and thermal hypersensitivity as seen between CON and MS in our behavioral experiments.

#### 4.3. Glial activation is depressed in animals with early life stress history

Nerve injury is associated with a strong activation of glial cells (Mika et al., 2013). This activation results in the release of pro-inflammatory cytokines and growth factors involved in the establishment of central sensitization and in the development of neuropathic pain (Marchand et al., 2005). In this context microglia and astrocytes do not seem to be engaged in a similar manner. Iba1 and GFAP were respectively chosen as markers of microglia and astrocytes because they are both constitutively expressed and their expression is increased upon activation (Ito et al., 1998; McMahon et al., 2005), allowing us to evaluate basal and MS- or CCI-related levels. The pronounced and immediate microglia activation after injury (Tanga et al., 2004) is believed to play a more prominent role in the establishment of mechanical hypersensitivity (Raghavendra et al., 2004). Our results showing a more pronounced Iba1 mRNA expression 4 days after neuropathy followed by a recovery to lower levels at 21 days are in agreement with previous studies (Mika et al., 2010). However, since there is a delay between the behavioral establishment of a significant mechanical hyperalgesia and allodynia and the qPCR-related findings, it seems plausible that we could have missed the peak of microglia activation. Furthermore, variability can occur due to differences in neuropathy models. Indeed, it has been shown that the activation of immunocompetent cells may partly depend on the location and type of the nerve lesion (Colburn et al., 1999; Hu et al., 2007). MS animals presented lower microglia activation than CON animals during normal and neuropathic conditions. Despite an increase of Iba1 mRNA levels following CCI, microglial activity seemed dampened in MS animals. This is consistent with the higher mechanical threshold observed from day 7–14 after CCI. The lack of difference in mechanical thresholds between CON + CCI and MS + CCI animals 21 days after surgery could be another indication that microglia was predominantly involved in the establishment of mechanical hypersensitivity but not in its maintenance. Astrocytic activation is weaker but long lasting (Mika et al., 2013). Maintenance of neuropathic states may depend on this sustained activation. Our result is consistent with the existing literature since the CON + CCI group presented an early but mild GFAP mRNA level increase which was sustained until post-CCI day 21. It is interesting to note that the astrocytic activation was also dampened in the MS + CCI group during neuropathic pain.

Glial activation plays a capital role in neuropathic pain through the release of pro-inflammatory cytokines (Ledeboer et al., 2005) and neurotrophins (Li et al., 2003). We focused on the interleukins 1-beta (IL-1 $\beta$ ) and 6 (IL-6) due to their well-documented involvement in neuropathic states. Upon nerve injury, IL-1 $\beta$  is released concomitantly with the induction of allodynia and hyperalgesia through its actions on NMDA and GABA currents (Kawasaki et al., 2008; Wolf et al., 2006). IL-1 $\beta$  also induces the secretion of other inflammatory mediators such as itself, IL-6, TNF- $\alpha$  or NGF therefore contributing to neuropathic pain (Marchand et al., 2005).

CCI alone induced a clear increase of IL-1 $\beta$  mRNA levels 4 days after the surgery and started to recover at 21 days. On the contrary, in MS the onset and extent of this upregulation was delayed. IL-6 on the other hand presented a similar expression pattern in CON and MS 4 and 21 days after induction of neuropathic pain.

It is interesting to note that, in concordance with the Iba1 and GFAP expression results, MS had an overall dampening effect on the regulation of pro-inflammatory cytokines in the early phase of neuropathy, but not later at the beginning state of chronification. This could be of importance because IL-1 $\beta$  and IL-6 increase are both associated with the development of abnormal sensitivity during neuropathic pain due to their capacity to enhance not only NMDA receptor currents but also AMPA receptor-mediated post-synaptic potentials (Liu et al., 2013; Schäfers and Sorkin, 2008). The MS-related dampened immunocompetent reactivity observed in our hands could explain the enhanced thermal and mechanical thresholds of these animals seen

during the early neuropathic pain states. Although a longer observation period of neuropathy may be required, these results seem to indicate that MS delays or reduces the appearance of neuropathy-related pain hypersensitivity.

#### 4.4. MS affects CCI-induced alterations in growth factor mRNA expression

Neurotrophins such as NGF are additional pro-algesic mediators released in the spinal cord upon nerve injury (Li et al., 2003). The increase of NGF levels shortly after CCI surgery observed in this study could result from glial activation-related secretion of IL-1 $\beta$  (Spranger et al., 1990). This would be in line with the decreased thermal threshold observed shortly after the CCI surgery in CON animals since NGF is known to be retrogradely transported to the periphery resulting in a sensitization of nociceptors (Ji et al., 2002). In addition, TRPM8 a cation channel able to sense both innocuous and noxious cold, notably after nerve injury (Xing et al., 2007), has been shown to be upregulated in a NGF-dependent manner (Babes et al., 2004). In the present study, NGF mRNA expression was decreased in MS animals shortly after CCI potentially resulting in a higher cold threshold as compared to controls. The return to basal mRNA levels at day 21 post-CCI may consequently have lowered the threshold to cold stimuli. However, the increase of NGF mRNA levels cannot solely explain the course of cold hyperalgesia/allodynia since CON + CCI animals presented a decrease of NGF mRNA levels at 21 days post CCI while remaining highly sensitive.

The implication of GDNF in neuropathic pain is controversial due to its potent analgesic effect following intrathecal administration (Boucher et al., 2000) while it can also sensitize nociceptors leading to mechanical hyperalgesia (Bogen et al., 2008). The slight decrease in MS animals and the lack of change in CON animals 4 days after surgery suggest that GDNF did not participate to a great extent to the establishment of neuropathic pain. However, given the mechanical threshold of both groups 21 days after surgery, we hypothesize that GDNF might have displayed a pro-algesic effect. Indeed, the decrease of GDNF mRNA expression in the CON group during neuropathy is concomitant with a reduction of mechanical allodynia/hyperalgesia and the increase of GDNF mRNA in MS animals would agree with the ongoing decrease in abnormal mechanical thresholds.

## 5. Conclusion

Our study surprisingly shows that MS protects from an increase or at least delays the occurrence of neuropathy-related pain hypersensitivity. The assessed biochemical markers do not fully reveal the biochemical cascades involved in the MS-related modification of pain thresholds under neuropathic conditions. Considering that most nociceptive primary afferents project to the dorsal horn of the spinal cord (Basbaum et al., 2009), it is conceivable that an analysis of biochemical markers restricted to the dorsal quadrant would yield stronger effects after CCI than one that includes dorsal and ventral quadrants as was done here. Further studies are required to confirm these results and to eventually elucidate the mechanisms involved in the described stress-related resilience to neuropathic pain. In this framework it will be important to extend the biochemical investigations to the respective protein levels. Importantly, MS has been shown to have differential effects on males and females. Moreover the additionally observed sexual dimorphism in the framework of neuropathic pain has recently been shown to be mediated by sex-based differences in immune responses (Sorge et al., 2015). It thus remains essential to investigate the impact of MS on neuropathic pain as potentially underlying sex-dependent mechanisms. Electrophysiological and pharmacological studies should further add to the elucidation of these relationships.

## Author contributions

JG, FA and UH derived the original design of the study; JG, MT and

UH acquired, analysed and interpreted the data; JG and MT drafted the original manuscript; UH and FA revised the manuscript. All authors read and approved the final manuscript.

### Conflicts of interest

The authors declare no conflict of interest.

### Funding

This research did not receive any specific grant from funding agencies in the public, commercial, or not-for-profit sectors.

### Acknowledgments

The authors thank Yvonne Hicks for her excellent technical assistance.

### References

- Abe, T., Matsumura, S., Katano, T., Mabuchi, T., Takagi, K., Xu, L., Yamamoto, A., Hattori, K., Yagi, T., Watanabe, M., Nakazawa, T., Yamamoto, T., Mishina, M., Nakai, Y., Ito, S., 2005. Fyn kinase-mediated phosphorylation of NMDA receptor NR2B subunit at Tyr1472 is essential for maintenance of neuropathic pain. *Eur. J. Neurosci.* 22, 1445–1454. <http://dx.doi.org/10.1111/j.1460-9568.2005.04340.x>.
- Alvarez, P., Green, P.G., Levine, J.D., 2013. Stress in the adult rat exacerbates muscle pain induced by early-life stress. *Biol. Psychiatry* 74, 688–695. <http://dx.doi.org/10.1016/j.biopsych.2013.04.006>.
- Arts, J.W.M., Kramer, K., Arndt, S.S., Ohl, F., 2012. The impact of transportation on physiological and behavioral parameters in Wistar rats: implications for acclimatization periods. *ILAR J.* 53, E82–E98. <http://dx.doi.org/10.1093/ilar.53.1.82>.
- Babes, A., Zorzon, D., Reid, G., 2004. Two populations of cold-sensitive neurons in rat dorsal root ganglia and their modulation by nerve growth factor. *Eur. J. Neurosci.* 20, 2276–2282. <http://dx.doi.org/10.1111/j.1460-9568.2004.03695.x>.
- Basbaum, A.I., Bautista, D.M., Scherrer, G., Julius, D., 2009. Cellular and molecular mechanisms of pain. *Cell* 139, 267–284. <http://dx.doi.org/10.1016/j.cell.2009.09.028>.
- Bennett, G.J., Xie, Y.K., 1988. A peripheral mononeuropathy in rat that produces disorders of pain sensation like those seen in man. *Pain* 33, 87–107. [https://doi.org/10.1016/0304-3959\(88\)90209-6](https://doi.org/10.1016/0304-3959(88)90209-6).
- Bilbo, S.D., Schwarz, J.M., 2009. Early-life programming of later-life brain and behavior: a critical role for the immune system. *Front. Behav. Neurosci.* 3, 14. <http://dx.doi.org/10.3389/neuro.08.014.2009>.
- Bogen, O., Joseph, E.K., Chen, X., Levine, J.D., 2008. GDNF hyperalgesia is mediated by PLC $\gamma$  MAPK/ERK, PI3K, CDK5 and Src family kinase signaling and dependent on the IB4-binding protein versican. *Eur. J. Neurosci.* 28, 12–19. <http://dx.doi.org/10.1111/j.1460-9568.2008.06308.x>.
- Boucher, T.J., Okuse, K., Bennett, D.L.H., Munson, J.B., Wood, J.N., McMahon, S.B., 2000. Potent analgesic effects of GDNF in neuropathic pain states. *Sci. (80- )* 290, 124–127. <http://dx.doi.org/10.1126/science.290.5489.124>.
- Caldji, C., Tannenbaum, B., Sharma, S., Francis, D., Plotsky, P.M., Meaney, M.J., 1998. Maternal care during infancy regulates the development of neural systems mediating the expression of fearfulness in the rat. *Proc. Natl. Acad. Sci. U. S. A.* 95, 5335–5340. <http://dx.doi.org/10.1073/pnas.95.9.5335>.
- Carpenter, L.L., Gawuga, C.E., Tyrka, A.R., Lee, J.K., Anderson, G.M., Price, L.H., 2010. Association between plasma IL-6 response to acute stress and early-life adversity in healthy adults. *Neuropsychopharmacology* 35, 2617–2623. <http://dx.doi.org/10.1038/npp.2010.159>.
- Chung, E.K.Y., Zhang, X.-J., Xu, H.-X., Sung, J.J.Y., Bian, Z.-X., 2007. Visceral hyperalgesia induced by neonatal maternal separation is associated with nerve growth factor-mediated central neuronal plasticity in rat spinal cord. *Neuroscience* 149, 685–695. <http://dx.doi.org/10.1016/j.neuroscience.2007.07.055>.
- Colburn, R.W., Rickman, A.J., DeLeo, J.A., 1999. The effect of site and type of nerve injury on spinal glial activation and neuropathic pain behavior. *Exp. Neurol* 157, 289–304. <http://dx.doi.org/10.1006/exnr.1999.7065>.
- Danbolt, N.C., 2001. Glutamate uptake. *Prog. Neurobiol.* 65, 1–105. [http://dx.doi.org/10.1016/S0301-0082\(00\)00067-8](http://dx.doi.org/10.1016/S0301-0082(00)00067-8).
- Dickinson, A.L., Leach, M., Flecknell, P.A., 2009. Influence of early neonatal experience on nociceptive responses and analgesic effects in rats. *Lab. Anim.* 43, 11–16. <http://dx.doi.org/10.1258/la.2007.007078>.
- Faure, J., Uys, J.D.K., Marais, L., Stein, D.J., Daniels, W.M.U., 2007. Early maternal separation alters the response to traumatization: resulting in increased levels of hippocampal neurotrophic factors. *Metab. Brain Dis.* 22, 183–195. <http://dx.doi.org/10.1007/s11011-007-9048-3>.
- Gosselin, R.D., O'Connor, R.M., Tramullas, M., Julio-Pieper, M., Dinan, T.G., Cryan, J.F., 2010. Riluzole normalizes early-life stress-induced visceral hypersensitivity in rats: role of spinal glutamate reuptake mechanisms. *Gastroenterology* 138, 2418–2425. <http://dx.doi.org/10.1053/j.gastro.2010.03.003>.
- Green, P.G., Chen, X., Alvarez, P., Ferrari, L.F., Levine, J.D., 2011. Early-life stress produces muscle hyperalgesia and nociceptor sensitization in the adult rat. *Pain* 152, 2549–2556. <http://dx.doi.org/10.1016/j.pain.2011.07.021>.
- Heim, C., Binder, E.B., 2012. Current research trends in early life stress and depression: review of human studies on sensitive periods, gene-environment interactions, and epigenetics. *Exp. Neurol.* 233, 102–111. <http://dx.doi.org/10.1016/j.expneurol.2011.10.032>.
- Heim, C., Shugart, M., Craighead, W.E., Nemeroff, C.B., 2010. Neurobiological and psychiatric consequences of child abuse and neglect. *Dev. Psychobiol.* 52, 671–690. <http://dx.doi.org/10.1002/dev.20494>.
- Hu, P., Bembrick, A.L., Keay, K.A., McLachlan, E.M., 2007. Immune cell involvement in dorsal root ganglia and spinal cord after chronic constriction or transection of the rat sciatic nerve. *Brain. Behav. Immun.* 21, 599–616. <http://dx.doi.org/10.1016/j.bbi.2006.10.013>.
- Ito, D., Imai, Y., Ohsawa, K., Nakajima, K., Fukuuchi, Y., Kohsaka, S., 1998. Microglia-specific localisation of a novel calcium binding protein. Iba1. *Mol. Brain Res.* 57 (1), 1–9. [http://dx.doi.org/10.1016/S0169-328X\(98\)00040-0](http://dx.doi.org/10.1016/S0169-328X(98)00040-0).
- Ji, R.R., Samad, T.A., Jin, S.X., Schmolli, R., Woolf, C.J., 2002. p38 MAPK activation by NGF in primary sensory neurons after inflammation increases TRPV1 levels and maintains heat hyperalgesia. *Neuron* 36, 57–68. [http://dx.doi.org/10.1016/S0896-6273\(02\)00908-X](http://dx.doi.org/10.1016/S0896-6273(02)00908-X).
- Kalinichev, M., Easterling, K.W., Holtzman, S.G., 2001. Repeated neonatal maternal separation alters morphine-induced antinociception in male rats. *Brain Res. Bull.* 54, 649–654.
- Karlsson, U., Sjödin, J., Möller, K.Å., Johansson, S., Wikström, L., Näsström, J., 2002. Glutamate-induced currents reveal three functionally distinct NMDA receptor populations in rat dorsal horn - effects of peripheral nerve lesion and inflammation. *Neuroscience* 112, 861–868. [http://dx.doi.org/10.1016/S0306-4522\(02\)00140-9](http://dx.doi.org/10.1016/S0306-4522(02)00140-9).
- Kawasaki, Y., Zhang, L., Cheng, J.-K., Ji, R.-R., 2008. Cytokine mechanisms of central sensitization: distinct and overlapping role of interleukin-1beta, interleukin-6, and tumor necrosis factor-alpha in regulating synaptic and neuronal activity in the superficial spinal cord. *J. Neurosci.* 28, 5189–5194. <http://dx.doi.org/10.1523/JNEUROSCI.3338-07.2008>.
- Krishnan, V., Nestler, E.J., 2008. The molecular neurobiology of depression. *Nature* 455 (7215), 894–902. <https://doi.org/10.1038/nature07455>.
- Ladd, C.O., Huot, R.L., Thirivikraman, K.V., Nemeroff, C.B., Plotsky, P.M., 2004. Long-term adaptations in glucocorticoid receptor and mineralocorticoid receptor mRNA and negative feedback on the hypothalamo-pituitary-adrenal axis following neonatal maternal separation. *Biol. Psychiatry* 55, 367–375. <http://dx.doi.org/10.1016/j.biopsych.2003.10.007>.
- Ledeboer, A., Sloane, E.M., Milligan, E.D., Frank, M.G., Mahony, J.H., Maier, S.F., Watkins, L.R., 2005. Minocycline attenuates mechanical allodynia and proinflammatory cytokine expression in rat models of pain facilitation. *Pain* 115, 71–83. <http://dx.doi.org/10.1016/j.pain.2005.02.009>.
- Levine, S., 2001. Primary social relationships influence the development of the hypothalamic-pituitary-adrenal axis in the rat. *Physiol. Behav.* 73, 255–260. [http://dx.doi.org/10.1016/S0031-9384\(01\)00496-6](http://dx.doi.org/10.1016/S0031-9384(01)00496-6).
- Li, L., Xian, C.J., Zhong, J.H., Zhou, X.F., 2003. Lumbar 5 ventral root transection-induced upregulation of nerve growth factor in sensory neurons and their target tissues: a mechanism in neuropathic pain. *Mol. Cell. Neurosci.* 23, 232–250. [http://dx.doi.org/10.1016/S1044-7431\(03\)00062-9](http://dx.doi.org/10.1016/S1044-7431(03)00062-9).
- Liaw, W.J., Stephens, R.L., Binns, B.C., Chu, Y., Sepkuty, J.P., Johns, R.A., Rothstein, J.D., Tao, Y.X., 2005. Spinal glutamate uptake is critical for maintaining normal sensory transmission in rat spinal cord. *Pain* 115, 60–70. <http://dx.doi.org/10.1016/j.pain.2005.02.006>.
- Lippmann, M., Bress, A., Nemeroff, C.B., Plotsky, P.M., Monteggia, L.M., 2007. Long-term behavioural and molecular alterations associated with maternal separation in rats. *Eur. J. Neurosci.* 25, 3091–3098. <http://dx.doi.org/10.1111/j.1460-9568.2007.05522.x>.
- Liu, T., Jiang, C.-Y., Fujita, T., Luo, S.-W., Kumamoto, E., 2013. Enhancement by interleukin-1 $\beta$  of AMPA and NMDA receptor-mediated currents in adult rat spinal superficial dorsal horn neurons. *Mol. Pain* 9, 16. <http://dx.doi.org/10.1186/1744-8069-9-16>.
- Lupien, S.J., McEwen, B.S., Gunnar, M.R., Heim, C., 2009. Effects of stress throughout the lifespan on the brain, behaviour and cognition. *Nat. Rev. Neurosci.* 10, 434–445. <http://dx.doi.org/10.1038/nrn2639>.
- Macri, S., Zoratto, F., Laviola, G., 2011. Early-stress regulates resilience, vulnerability and experimental validity in laboratory rodents through mother-offspring hormonal transfer. *Neurosci. Biobehav. Rev.* 35, 1534–1543. <http://dx.doi.org/10.1016/j.neubiorev.2010.12.014>.
- Marchand, F., Perretti, M., McMahon, S.B., 2005. Role of the immune system in chronic pain. *Nat. Rev. Neurosci.* 6, 521–532. <http://dx.doi.org/10.1038/nrn1700>.
- McMahon, S.B., Cafferty, W.B.J., Marchand, F., 2005. Immune and glial cell factors as pain mediators and modulators. *Exp. Neurol.* 192 (2), 444–462. <http://dx.doi.org/10.1016/j.expneurol.2004.11.001>.
- Mika, J., Rojewska, E., Makuch, W., Przewlocka, B., 2010. Minocycline reduces the injury-induced expression of prodynorphin and pronociceptin in the dorsal root ganglion in a rat model of neuropathic pain. *Neuroscience* 165, 1420–1428. <http://dx.doi.org/10.1016/j.neuroscience.2009.11.064>.
- Mika, J., Zychowska, M., Popiolek-Barczyk, K., Rojewska, E., Przewlocka, B., 2013. Importance of glial activation in neuropathic pain. *Eur. J. Pharmacol.* 716, 106–119. <http://dx.doi.org/10.1016/j.ejphar.2013.01.072>.
- Mintz, M., Rüedi-Bettschen, D., Feldon, J., Pryce, C.R., 2005. Early social and physical deprivation leads to reduced social motivation in adulthood in Wistar rats. *Behav. Brain Res.* 156, 311–320. <http://dx.doi.org/10.1016/j.bbr.2004.08.017>.
- Napier, I.A., Mohammadi, S.A., Christie, M.J., 2012. Glutamate transporter dysfunction associated with nerve injury-induced pain in mice. *J. Neurophysiol.* 107, 649–657. <http://dx.doi.org/10.1152/jn.00763.2011>.



- Nishinaka, T., Nakamoto, K., Tokuyama, S., 2016. Early life stress induces sex-dependent increases in phosphorylated extracellular signal-regulated kinase in brains of mice with neuropathic pain. *Eur. J. Pain* 20 (8), 1346–1356. <http://dx.doi.org/10.1002/ejp.860>.
- O'Mahony, S.M., Marchesi, J.R., Scully, P., Codling, C., Ceolho, A.M., Quigley, E.M.M., Cryan, J.F., Dinan, T.G., 2009. Early life stress alters behavior, immunity, and microbiota in rats: implications for irritable bowel syndrome and psychiatric illnesses. *Biol. Psychiatry* 65, 263–267. <http://dx.doi.org/10.1016/j.biopsych.2008.06.026>.
- Paoletti, P., Bellone, C., Zhou, Q., 2013. NMDA receptor subunit diversity: impact on receptor properties, synaptic plasticity and disease. *Nat. Rev. Neurosci.* 14, 383–400. <http://dx.doi.org/10.1038/nrn3504>.
- Patacchioli, F.R., Angelucci, L., Casolini, P., Bottone, A., Borboni, P., Lauro, R., Marlier, L.N.J.L., 1998. Corticosterone treatment differentially affects adrenocorticoid receptors expression and binding in the hippocampus and spinal cord of the rat. *J. Mol. Neurosci.* 11, 95–103 doi: JMN:11:1:95 [pii] \\r10.1385/JMN:11:1:95.
- Pfau, M.L., Russo, S.J., 2015. Peripheral and central mechanisms of stress resilience. *Neurobiol. Stress* 1, 66–79. <http://dx.doi.org/10.1016/j.ynstr.2014.09.004>.
- Prusator, D.K., Greenwood-Van Meerveld, B., 2016. Sex differences in stress-induced visceral hypersensitivity following early life adversity: a two hit model. *Neurogastroenterol. Motil.* 28, 1876–1889. <http://dx.doi.org/10.1111/nmo.12891>.
- Raghavendra, V., Tanga, F.Y., DeLeo, J.A., 2004. Complete Freund's adjuvant-induced peripheral inflammation evokes glial activation and proinflammatory cytokine expression in the CNS. *Eur. J. Neurosci.* 20, 467–473. <http://dx.doi.org/10.1111/j.1460-9568.2004.03514.x>.
- Rana, S., Pugh, P.C., Jackson, N., Clinton, S.M., Kerman, I.A., 2014. Inborn stress reactivity shapes adult behavioral consequences of early-life maternal separation stress. *Neurosci. Lett.* 584C, 146–150. <http://dx.doi.org/10.1016/j.neulet.2014.10.011>.
- Roque, A., Ochoa-Zarzosa, A., Torner, L., 2015. Maternal separation activates microglial cells and induces an inflammatory response in the hippocampus of male rat pups, independently of hypothalamic and peripheral cytokine levels. *Brain. Behav. Immun.* <http://dx.doi.org/10.1016/j.bbi.2015.09.017>.
- Sandkühler, J., 2009. Models and mechanisms of hyperalgesia and allodynia. *Physiol. Rev.* 89, 707–758. <http://dx.doi.org/10.1152/physrev.00025.2008>.
- Sapolsky, R.M., Meaney, M.J., 1986. Maturation of the adrenocortical stress response: neuroendocrine control mechanisms and the stress hyporesponsive period. *Brain Res. Rev.* 11, 65–76. [http://dx.doi.org/10.1016/0165-0173\(86\)90010-X](http://dx.doi.org/10.1016/0165-0173(86)90010-X).
- Schäfers, M., Sorkin, L., 2008. Effect of cytokines on neuronal excitability. *Neurosci. Lett.* 437, 188–193. <http://dx.doi.org/10.1016/j.neulet.2008.03.052>.
- Schmidt, M.V., 2010. Molecular mechanisms of early life stress-lessons from mouse models. *Neurosci. Biobehav. Rev.* 34, 845–852. <http://dx.doi.org/10.1016/j.neubiorev.2009.05.002>.
- Schwaller, F., Fitzgerald, M., 2014. The consequences of pain in early life: injury-induced plasticity in developing pain pathways. *Eur. J. Neurosci.* 39, 344–352. <http://dx.doi.org/10.1111/ejn.12414>.
- Sorge, R.E., Mapplebeck, J.C.S., Rosen, S., Beggs, S., Alexander, J.K., Martin, L.J., Austin, J.-S., Sotocinal, S.G., Chen, D., Yang, M., Shi, X.Q., Huand, H., Pillon, N.J., Bilan, P.J., Tu, Y., Klip, A., Ji, R.-R., Zhang, J., Salter, M.W., Mogil, J.S., 2015. Different immune cells mediate mechanical pain hypersensitivity in male and female mice. *Nat. Neurosci.* 18 (8), 1081–1085. <http://dx.doi.org/10.1038/nn.4053>.
- Spranger, M., Lindholm, D., Bandtlow, C., Heumann, R., Gnahn, H., Naher-Noe, M., Thoenen, H., 1990. Regulation of nerve growth factor (NGF) synthesis in the rat central nervous system: comparison between the effects of interleukin-1 and various growth factors in astrocyte cultures and in vivo. *Eur. J. Neurosci.* 2, 69–76. <http://dx.doi.org/10.1111/j.1460-9568.1990.tb00382.x>.
- Strüber, N., Strüber, D., Roth, G., 2014. Impact of early adversity on glucocorticoid regulation and later mental disorders. *Neurosci. Biobehav. Rev.* 38, 17–37. <http://dx.doi.org/10.1016/j.neubiorev.2013.10.015>.
- Sung, B., Lim, G., Mao, J., 2003. Altered expression and uptake activity of spinal glutamate transporters after nerve injury contribute to the pathogenesis of neuropathic pain in rats. *J. Neurosci.* 23 (7), 2899–2910.
- Tanga, F.Y., Raghavendra, V., DeLeo, J.A., 2004. Quantitative real-time RT-PCR assessment of spinal microglial and astrocytic activation markers in a rat model of neuropathic pain. *Neurochem. Int.* 45, 397–407. <http://dx.doi.org/10.1016/j.neuint.2003.06.002>.
- Toya, S., Takatsuru, Y., Kokubo, M., Amano, I., Shimokawa, N., Koibuchi, N., 2014. Early-life-stress affects the homeostasis of glutamatergic synapses. *Eur. J. Neurosci.* 40 (11), 3627–3634. <http://dx.doi.org/10.1111/ejn.12728>.
- Tsang, S.W., Zhao, M., Wu, J., Sung, J.J.Y., Bian, Z.-X., 2012. Nerve growth factor-mediated neuronal plasticity in spinal cord contributes to neonatal maternal separation-induced visceral hypersensitivity in rats. *Eur. J. Pain* 16, 463–472. <http://dx.doi.org/10.1016/j.ejpain.2011.07.005>.
- Uhelski, M.L., Fuchs, P.N., 2010. Maternal separation stress leads to enhanced emotional responses to noxious stimuli in adult rats. *Behav. Brain Res.* 212, 208–212. <http://dx.doi.org/10.1016/j.bbr.2010.03.055>.
- von Hehn, C.A., Baron, R., Woolf, C.J., 2012. Deconstructing the neuropathic pain phenotype to reveal neural mechanisms. *Neuron* 73, 638–652. <http://dx.doi.org/10.1016/j.neuron.2012.02.008>.
- Wang, S., Lim, G., Yang, L., Sung, B., Mao, J., 2006. Downregulation of spinal glutamate transporter EAAC1 following nerve injury is regulated by central glucocorticoid receptors in rats. *Pain* 120, 78–85. <http://dx.doi.org/10.1016/j.pain.2005.10.015>.
- Wang, S., Lim, G., Zeng, Q., Sung, B., Ai, Y., Guo, G., Yang, L., Mao, J., 2004. Expression of central glucocorticoid receptors after peripheral nerve injury contributes to neuropathic pain behaviors in rats \\r10.1523/JNEUROSCI.3058-04.2004. *J. Neurosci.* 24, 8595–8605. <http://dx.doi.org/10.1523/JNEUROSCI.3058-04.2004>.
- Wang, S., Lim, G., Zeng, Q., Sung, B., Yang, L., Mao, J., 2005. Central glucocorticoid receptors modulate the expression and function of spinal NMDA receptors after peripheral nerve injury. *J. Neurosci.* 25, 488–495. <http://dx.doi.org/10.1523/JNEUROSCI.4127-04.2005>.
- Weaver, S.A., Diorio, J., Meaney, M.J., 2007. Maternal separation leads to persistent reductions in pain sensitivity in female rats. *J. Pain* 8, 962–969. <http://dx.doi.org/10.1016/j.jpain.2007.07.001>.
- Weinstock, M., 2008. The long-term behavioural consequences of prenatal stress. *Neurosci. Biobehav. Rev.* 32, 1073–1086. <http://dx.doi.org/10.1016/j.neubiorev.2008.03.002>.
- Wieck, A., Andersen, S.L., Brenhouse, H.C., 2013. Evidence for a neuroinflammatory mechanism in delayed effects of early life adversity in rats: relationship to cortical NMDA receptor expression. *Brain. Behav. Immun.* 28, 218–226. <http://dx.doi.org/10.1016/j.bbi.2012.11.012>.
- Wilson, J.A., Garry, E.M., Anderson, H.A., Rosie, R., Colvin, L.A., Mitchell, R., Fleetwood-Walker, S.M., 2005. NMDA receptor antagonist treatment at the time of nerve injury prevents injury-induced changes in spinal NR1 and NR2B subunit expression and increases the sensitivity of residual pain behaviours to subsequently administered NMDA receptor antagonists. *Pain* 117, 421–432. <http://dx.doi.org/10.1016/j.pain.2005.07.005>.
- Wolf, G., Gabay, E., Tal, M., Yirmiya, R., Shavit, Y., 2006. Genetic impairment of interleukin-1 signaling attenuates neuropathic pain, autotomy, and spontaneous ectopic neuronal activity, following nerve injury in mice. *Pain* 120, 315–324. <http://dx.doi.org/10.1016/j.pain.2005.11.011>.
- Wu, L.-J., Zhuo, M., 2009. Targeting the NMDA receptor subunit NR2B for the treatment of neuropathic pain. *Neurotherapeutics* 6, 693–702. <http://dx.doi.org/10.1016/j.nurt.2009.07.008>.
- Xin, W.-J., Weng, H.-R., Dougherty, P.M., 2009. Plasticity in expression of the glutamate transporters GLT-1 and GLAST in spinal dorsal horn glial cells following partial sciatic nerve ligation. *Mol. Pain* 5, 15. <http://dx.doi.org/10.1186/1744-8069-5-15>.
- Xing, H., Chen, M., Ling, J., Tan, W., Gu, J.G., 2007. TRPM8 mechanism of cold allodynia after chronic nerve injury. *J. Neurosci.* 27, 13680–13690. <http://dx.doi.org/10.1523/jneurosci.2203-07.2007>.
- Zell, V., Juif, P.-E., Hanesch, U., Poisbeau, P., Anton, F., Darbon, P., 2015. Corticosterone analgesia is mediated by the spinal production of neuroactive metabolites that enhance GABAergic inhibitory transmission on dorsal horn rat neurons. *Eur. J. Neurosci.* 41 (3), 390–397. <http://dx.doi.org/10.1111/ejn.12796>.
- Zeng, Q., Wang, S., Lim, G., Yang, L., Mao, J., Sung, B., Chang, Y., Lim, J.-A., Guo, G., Mao, J., 2008. Exacerbated mechanical allodynia in rats with depression-like behavior. *Brain Res.* 1200, 27–38. <http://dx.doi.org/10.1016/j.brainres.2008.01.038>.