

Impact of Transcranial Direct Current Stimulation on Reading Skills of Children and Adolescents With Dyslexia

Débora Medeiros Rios, MSc¹, Mino Correia Rios, PhD²,
 Igor Dórea Bandeira, MD, MBMSc¹, Fernanda Queiros Campbell, SLP, PhD³,
 Daniel de Carvalho Vaz, SLP¹, and Rita Lucena, MD, PhD¹

Abstract

Introduction: Rehabilitation techniques have been used to facilitate reading acquisition in dyslexia. However, many individuals continue to present academic impairment throughout life. New intervention strategies are necessary to further help this population. **Objectives:** Assess the impact of transcranial direct current stimulation on reading skills in children and adolescents with dyslexia. **Methods:** The study was conducted with one-group pretest–posttest. Participants received 2 mA transcranial direct current stimulation during 30 minutes for 5 consecutive days. Reading performance was measured by a group of tasks (identification and reading of letters, syllables, words, nonwords, and text). **Results:** A significant increase in the number of correct answers for nonwords and text tasks was observed after transcranial direct current stimulation ($P = .035$ and $P = .012$, respectively). **Conclusion:** The transcranial direct current stimulation seems to be a promising tool for the treatment of reading problems in dyslexia. Future studies are necessary to confirm the effects of transcranial direct current stimulation and to establish optimal intervention protocol in this population.

Keywords

dyslexia, neuromodulation, noninvasive brain stimulation, transcranial direct current stimulation, children

Received July 24, 2017. Received revised July 26, 2018. Accepted for publication August 10, 2018.

Dyslexia is a neurodevelopmental disorder characterized by a persistent reading deficit despite normal intellectual potential, appropriate learning environment, and full educational opportunities.¹ Its prevalence has been estimated between 5% and 10% in school-aged children, depending on language and cultural background.^{2,3}

Studies have shown a strong genetic background for this disease.^{4–6} Specific genes seem to be involved in neuronal migration processes, axonal growth, and change in the cortical and subcortical structures.⁷ Moreover, neuroimaging studies in dyslexia displayed abnormal activation patterns of the cerebral cortex during the reading process, as well as abnormalities related to the distribution of gray and white matters.⁸

These cortical changes are mainly associated with deficits in phonological awareness, rapid automatized naming, and working memory.⁹ Rehabilitation techniques have been used to facilitate reading acquisitions¹⁰ including phonological awareness, visual, and auditory processing training.^{11–13} Although

functional imaging studies have shown activation of inferior frontal and occipitotemporal regions after auditory and phonological training,¹⁴ individuals still face significant academic challenges throughout the life span, despite interventions.^{15,16}

Several noninvasive brain stimulation techniques have been used in neuropsychiatric disorders with favorable results, including transcranial direct current stimulation.^{17–25} The

¹ Department of Neuroscience and Mental Health, Medical School of Bahia, Federal University of Bahia, Salvador, Brazil

² Psychology Institute, Federal University of Bahia, Salvador, Brazil

³ Department of Biomorphology, Health Sciences Institute, Federal University of Bahia, Salvador, Brazil

Corresponding Author:

Débora Medeiros Rios, MSc, Department of Neuroscience and Mental Health, Medical School of Bahia, Federal University of Bahia, Praça XV de Novembro, s/n—Largo do Terreiro de Jesus, Salvador, Bahia 40025-010, Brazil.
 Email: deborapesquisa@yahoo.com.br



transcranial direct current stimulation is considered a simple, safe, and low-cost technique, with positive results in the modulation of brain activity using anodic or cathodic currents.²⁶ Studies using transcranial direct current stimulation in the pediatric population have revealed mixed findings. Positive results after transcranial direct current stimulation include reduction of epileptic seizures,²⁷ improvement in static balance and functional abilities in cerebral palsy,²⁸ and functional improvement in children with autism.²⁹ Conversely, Bhanpuri et al³⁰ reported increased symptoms in children with dystonia.

Recent studies have shown that transcranial direct current stimulation can be a useful therapeutic tool to improve performance in cognitive tasks including arithmetic processing, verbal working memory, attention skills,³¹ and remodeling language networks.³² Previous studies including healthy adults without dyslexia have also suggested that the technique may improve reading. Thomson et al³³ reported improvement in reading speed of participants who received 20 minutes of 2 mA anodic stimulation at CP6 in the right hemisphere. According to Heth and Lavidor,³⁴ the use of 1.5 mA anodal stimulation in the V5/MT area for 20 minutes resulted in significant improvement in reading and fluency. A placebo-controlled study examining the effect of 1.5 mA anodic transcranial direct current stimulation applied for 20 minutes between T7 and TP7 (left hemisphere) resulted in improved reading efficiency of words.³⁵

To the best of our knowledge, only 3 studies to date have evaluated the effect of transcranial direct current stimulation on reading performance in individuals with alexia or dyslexia.^{36–38} Lacey et al³⁸ reported changes in activity and connectivity of the occipitotemporal cortex after 20 minutes of 2 mA transcranial direct current stimulation delivered between T7 and TP7 in an adult with alexia. Costanzo and collaborators^{36,37} conducted 2 studies with children and adolescents with dyslexia using 1 mA transcranial direct current stimulation for 20 minutes with the anode electrode placed between P7 and TP7 and the cathode between P8 and TP8. They reported mixed findings on the studied variables, with improvement in text reading,³⁶ reading of low-frequency words and nonwords reading speed.³⁷ There was not an increase in number of correct answers for nonwords and words.³⁶

Given the limitation of current therapeutic techniques and the potential benefits of transcranial direct current stimulation in cognitive rehabilitation, the current study aimed to assess the effect of transcranial direct current stimulation in reading skills (identification and reading of letters, syllables, words, nonwords, and text) of children and adolescents with dyslexia. We used a one-group pretest–posttest design to test our hypothesis, which is anodic t-DCS will increase reading skills in the studied sample.

Methods

Participants

This was a one-group pretest–posttest study. Individuals with dyslexia were recruited from the neuropsychiatric clinic at Professor Edgard Santos Teaching Hospital, Salvador-Bahia, Brazil.

We recruited 12 participants of both genders (3 female and 9 males), aged between 8 and 17 years old, right handed, and Brazilian Portuguese native speakers. The average age was 12.5 years (± 3.18). Children were in grades 1 through 12. At the Brazilian school system, children usually start at grade 1 when they reach 6 years of age and commence grade 12 at age 17 years. A child neurologist assessed all participants and diagnosed dyslexia according to the *Diagnostic and Statistical Manual of Mental Disorders* (Fifth Edition) criteria.³⁹ The neurologist and her team diagnosed dyslexia using the *Diagnostic and Statistical Manual of Mental Disorders* criteria, supported by the following Brazilian assessments: The Reading Processes Assessment⁴⁰ and the Phonological Awareness Test.⁴¹ The score analysis in each Reading Processes Assessment test classified the participants as belonging to the group with indicative of severe impairment in reading skills. Moreover, in the Phonological Awareness Test, all the participants demonstrated an unsatisfactory performance in the tasks of phonemic awareness. On both tests, all participants scored below the expected level for age and educational level.

All individuals had an estimated intelligence quotient of 90 or higher, according to Wechsler Intelligence Scale for Children-III; we did not include participants with visual and/or hearing impairment, intellectual disability, attention-deficit/hyperactivity disorder (the absence of attention-deficit hyperactivity disorder was assessed using the *Diagnostic and Statistical Manual of Mental Disorders* criteria), microcephaly (head circumference smaller than 32 cm), craniofacial anomalies, and epilepsy; we excluded participants with any contraindication to transcranial direct current stimulation, such as scalp dermatitis, cochlear implant, cardiac pacemaker, or metallic implant in the skull; all parents signed an informed consent and received a copy of it.

Assessments and Measures

Study tasks measured the ability to read letters, syllables, words, nonwords, and text before and after transcranial direct current stimulation treatment. Testing materials were developed by authors D.M.R. and R.L. (Available upon request). All stimuli were presented in a computer screen, one at a time, using a PowerPoint presentation (font Times New Roman, font size 130, font color black, in a white background). Participants seated comfortably facing the computer screen and were requested to read each stimulus aloud. The examiner sat beside the participant and waited until (s)he read the stimuli or stated “I do not know” before changing to the next one. All assessment sessions were recorded for offline judgment using a camera, positioned on a tripod, and focusing on the participant. Reading tasks followed the same order in all assessments (letter identification, words, nonwords, and text reading). For each one of these tasks, the total number of correct answers and reading time were calculated. The total number of correct answers for letter identification, words, and nonwords included only perfect reading of the target production. The total number of correct answers for text reading consisted of the total number of words read correctly in the text. During the offline assessment of these tasks, author D.P.M.S.R. measured reading time in seconds, using a chronometer. The reading time was the time elapsed from start to end of an attempt to produce the target block of letters and reading the words, nonwords, and the entire text. Each task is detailed below.

Letter identification task. At the beginning, 2 letters were presented as examples. Then, the 23 test letters were displayed

individually. The variables analyzed were total number of correct answer letter and reading time letter.

Syllable task. This task consisted of 39 syllables, starting with the easiest and ending with the hardest syllabic structures in the Brazilian Portuguese language (consonant-vowel, consonant-vowel-vowel, consonant-consonant-vowel, consonant-vowel-consonant, vowel-consonant). The variables analyzed were total number of correct answer syllable and reading time syllable.

Word task. The words in this test had 2 or 3 syllables, with different syllabic structures. The 32 words included all phonemes in the Brazilian Portuguese language. Our research team analyzed total number of correct answer word and reading time word.

Nonword task. This task contained 30 nonwords using the same syllabic structures present in the word task. Two additional nonwords were presented at the beginning of this task as an example. For this task, we analyzed total number of correct answer nonword and reading time nonword.

Text task. Two different texts, one with 56 and the other with 60 words each, of same complexity, were used for this task. The 56 word text was always used before the intervention, whereas the 60 word text was used post intervention. From this task, we analyzed variables total number of correct answer text and reading time text.

Percentage of change. In addition to the main analysis of comparing pre- and post-transcranial direct current stimulation means of the abovementioned variables, we performed qualitative assessments for each participant. Our research team included the qualitative assessment results due to the importance of individual changes in clinical practice. Using each individual baseline score, we computed an increase or decrease in the number of total number of correct answers for each task after the treatment. Thus, we reported individual percentages of score variation after transcranial direct current stimulation for all 5 reading tasks. For total number of correct answer scores, a positive value indicates the improvement in performance by the individual in a given task, whereas a negative value means a decrease in performance. A score of zero represents no change after treatment. Participants were assessed at the first day, before starting the stimulation session and after the final stimulation session on the last day.

Intervention

The transcranial direct current stimulation was performed using a pair of 7×5 cm (35 cm^2) electrodes in saline-soaked sponges and were held in place by elastic bandages. The device used was the Striat (IBRAMED, Amparo-SP, Brazil), regulated by the Brazilian Health Agency. The current intensity was adjusted to 2 mA for 30 minutes, with a 60-second ramp up and down at beginning and end of the stimulation. The intensity was based on a study that considered the 2 mA current well tolerated by children.⁴² The anode electrode was placed between the middle temporal (T3) and left posterior temporal (T5) areas, as determined by the 10–20 International electroencephalography system (Figure 1). This choice was based on recent studies that demonstrated patterns of activation in the superior temporal gyrus, which has been recognized as a crucial site in the development of reading skills.^{43,44} This finding holds true for both adults and children.⁴⁵ The cathode was placed on the right supraorbital region (FP2). During the stimulation, participants were instructed to remain relaxed and seated facing a wall, without access to any written materials. Stimulation on the first and last days took place 10 to 15 minutes after

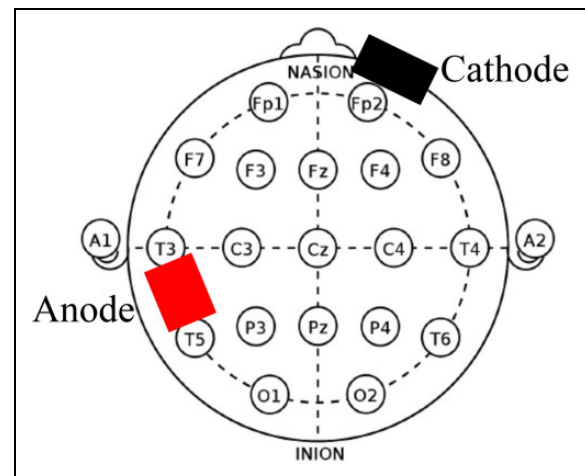

Figure 1. Placement of electrodes for anodic transcranial direct current stimulation. The anode (in red) was placed between the middle temporal (T3) and left posterior temporal (T5) areas, as determined by the 10–20 International electroencephalography system. The cathode (in black) was placed on the right supraorbital region (FP2).

and before the assessments, respectively. All stimulation parameters are considered safe for children and adolescents according to previous studies.^{24,46}

For 5 consecutive days, participants received an active, 2 mA transcranial direct current stimulation for 30 minutes. In this study, transcranial direct current stimulation was applied without the influence of cognitive tasks. Bortoletto et al⁴⁷ demonstrated that the simultaneous combination of a cognitive task and transcranial direct current stimulation can reduce neuroplasticity. Participants were questioned about side effects during and after treatment. A single investigator conducted all procedures to reduce measurement bias.

Recordings were edited, coded, and deidentified. The order of the 24 videos (pre- and post-treatment) was electronically randomized and saved in an external hard drive. Three speech-language pathologists, none involved in data collection, judged each task. The evaluators received the same instructions on how to judge each task and how to fill out the evaluation forms. Judges received training to improve interrater reliability. During the training stage, they initially arbitrated the same video, compared, and discussed answers. Subsequently, they judged another video, compared, and discussed their answers again. Judges' general concordance was measured with Cohen kappa coefficient (κ). We observed high agreement after training for all tasks: letters— $\kappa = 1$, $P < .001$; syllables— $\kappa = 0.791$, $P < .001$; words— $\kappa = 0.93$, $P < .001$; nonwords— $\kappa = 0.8$, $P < .001$; and text— $\kappa = 1$, $P < .001$. After the training, they received an external hard drive with the 24 coded, deidentified recordings. Data were analyzed by a statistician not involved in any of the previous stages of the study and was blind to the data coding.

Statistical analyses were performed using SPSS 21.0 for Windows.⁴⁸ Descriptive statistics were used to characterize the sample. Nonparametric Wilcoxon test was used to compare the scores before and after transcranial direct current stimulation sessions. G*Power version 3.1 was used to calculate effect size.⁴⁹ Effect size was calculated based on the method described by Morris and DeShon.⁵⁰ We followed the classification of Cohen (1988) and Rosenthal (1996) for the magnitude of the effect size: <0.19 —insignificant; between 0.20 and 0.49—small; between 0.50 and 0.79—medium; between 0.80 and

Table 1. Performance of Youth 8-to-16-Year Old With Dyslexia in Reading Tasks Pre- and Post-tDCS Intervention.^a

Reading tasks	Pre-tDCS, Mean (SD)	Post-tDCS, Mean (SD)	P Value	d (ES)
Letters				
TCA	18.92 (3.45)	20.25 (0.87)	.223	.45
RT	38.42 (10.87)	36.92 (12.92)	.530	.14
Syllables				
TCA	26.83 (11.45)	28.58 (10.30)	.055	.57
RT	144.83 (51.69)	155.92 (109.68)	.695	.15
Words				
TCA	25.10 (9.64)	25.00 (9.74)	.785	.07
RT	142.50 (136.67)	175.60 (208.64)	.169	.38
Nonwords				
TCA	16.70 (9.07)	18.70 (8.14)	.035 ^b	.87
RT	153.50 (107.72)	184.80 (185.30)	.475	.32
Words in the text				
TCA	43.11 (15.96)	48.11 (17.23)	.012 ^b	1.47
RT	65.78 (64.44)	65.33 (61.40)	.953	.07

Abbreviations: ES, effect size; RT, reading time; SD, standard deviation; tDCS, transcranial direct current stimulation; TCA, total number of correct answers.

^aDifferences were tested using Wilcoxon test. Reading time was measured in seconds. Number of participants who completed the tasks: Letter and Syllable, N = 12; Words and Nonwords, N = 10; Words in the text, N = 9. All 12 participants were presented with the 5 tasks, but some of them did not have the ability to give answers on tasks that were more complex.

^bIndicates a statistically significant value ($P < .05$).

1.29—large; and >1.30—very large.^{51,52} We considered statistically significant P values <.05.

Results

Table 1 presents pre- and postintervention scores for total number of correct answers and reading time. We found a significant increase for total number of correct answers of nonwords ($Z = 2.113$, $P = .035$, $r = 0.97$) and words read in text ($Z = 2.501$, $P = .012$, $r = 0.98$) after transcranial direct current stimulation. The total number of correct answers of letters, syllables, and words, as well as all reading time variables did not change after the intervention. Effect sizes are shown in the last column of Table 1. In terms of total number of correct answers, a very large and large effect size were observed for text and nonword tasks (1.47 and 0.87, respectively). The syllable task presented a medium effect size (.57), the letter task had a small (.45), and the word task presented an insignificant one (.07). For reading time, all effect size values were insignificant (ranging from 0.07 to 0.15), except for the words and nonword tasks, which presented small values (0.38 and 0.32, respectively).

Results for the individual percentage of change in reading tasks are presented in Table 2, along with sociodemographic characteristics. For the entire sample, 60 tasks were performed (5 for each participant). That number dropped to 53 because 3 participants did not complete 7 tasks. Looking at Table 2, the improvement in 25 (41.7%) total number of correct answer tasks for 11 participants is observable. The increase in total

number of correct answers indicates that participants had more answers that are correct after the intervention when compared to the baseline assessment. These improvements appear as positive percentage values, varying from 2.6% to 200% of change from the baseline scores.

Overall, individual performances postintervention in total number of correct answers were greater in the nonword task and the number of words read in the text tasks, with an average increment in correct responses of 43.6% and 32.2%, respectively. This result can be seen in the last row of Table 2. In letter and syllable tasks, improvement in total number of correct answers after transcranial direct current stimulation was observed in individuals 12-year old or younger.

Tingling (33.3%) and mild headache (25%) were the only adverse effects reported. These symptoms were mild and transient, as observed in previous studies.^{24,33}

Discussion

This study investigated the effects of five 2 mA transcranial direct current stimulation sessions on reading performance of children and adolescents with dyslexia to evaluate its impact. Results suggested that anodal transcranial direct current stimulation in the temporal may produce an increase in the number of correct answers for nonwords and words read in text tasks.

These findings are consistent with previous studies using transcranial direct current stimulation intervention to improve reading skills in children. Costanzo et al³⁶ studied children and adolescents aged between 10 and 17 years and looked at improvement in correct answers for nonwords, words, and text reading. These authors revealed a significant improvement in the text reading ($P < .001$), with reduction in errors after transcranial direct current stimulation. They placed the anode on the left side, approximately in the same region we stimulated in the current study (parietotemporal region) and the cathode in the right contralateral region. Despite the difference in cathode location between this study and that of Costanzo, both studies found positive effects on reading after anode stimulation in the left parietotemporal region. In addition, Costanzo and collaborators found an increase in reading errors in the reverse polarity condition.

In the current study, we also observed an improvement in the number of nonwords read, but not on the number of words. The same study of Costanzo et al,³⁶ comparatively to our results, found no significant effect of transcranial direct current stimulation on the word reading task. Contrary to our findings, these authors did not observe improvement in nonword reading. A single transcranial direct current stimulation session, as argued by Costanzo et al,³⁶ may not suffice to induce changes in several reading tasks. They suggested that multiple sessions, as used in our study, may lead to greater and lasting changes.

Another study³⁷ in children with dyslexia aged 10 to 17 years showed a significant effect of transcranial direct current stimulation on nonword reading speed ($P = .04$) and error reduction after transcranial direct current stimulation in the low-frequency word task ($P = .02$), but not in error reduction

Table 2. Individual Percentage of Change in the Number of Total Correct Answers in Reading Tasks Post-tDCS for Youth 8-to-16-Year Old With Dyslexia.^a

Participant	Age	School Grade	Gender	TCA				
				Letters	Syllables	Words	Nonwords	Texts
1	8	2	F	72.7	0	NR	NR	NR
2	8	2	M	-5	50	NR	NR	NR
3	10	5	M	0	-3.1	-11.1	0	10.2
4	10	4	M	46.2	22.2	0	150	NR
5	12	5	F	23.5	66.7	0	100	200
6	12	5	M	0	13.8	0	35.7	21.3
7	12	5	M	0	2.6	10.7	9.1	10.4
8	15	7	M	0	0	0	6.3	11.4
9	15	9	M	0	11.4	-3.4	20	16.3
10	16	9	M	0	0	0	0	11.5
11	16	10	F	0	-10.3	0	35.7	12.8
12	17	10	M	-4.8	0	0	-7.7	-3.9
Mean total percentage of change				26.5	19.2	-1.3	43.6	32.2

Abbreviations: NR, no response; TCA, total of number correct answers; tDCS, transcranial direct current stimulation.

^aA positive value on TCA indicates increase, whereas a negative value indicates decrease, and zero represents no change in the number of correct answers after the tDCS intervention. The last line on this table represents the average percentage of change for each variable in the entire sample.

in high-frequency words, nonwords, and text. Participants received 18 days of anodic transcranial direct current stimulation, spread through 6 weeks (anode placed in the parietotemporal area and cathode in the contralateral area). Additionally, participants performed phonetic and text reading training during transcranial direct current stimulation sessions. According to Turkeltaub et al,³⁵ in a study with individuals without reading deficits, the association of transcranial direct current stimulation sessions with reading interventions focusing on the impaired reading skills for each individual may optimize the effect of transcranial direct current stimulation on reading performance. Another study, however, suggested the contrary.⁴⁵ We based our choice of not using cognitive activities during stimulation based on previous work suggesting that plasticity induced by transcranial direct current stimulation is task dependent. The use of a cognitive task concomitant to transcranial direct current stimulation may reduce learning if the task induces an increase in cortical excitability, triggering an undesired nonadditive mechanism that may hinder neuroplasticity, which we wanted to avoid.⁴⁷

Despite the differences in the use or nonuse of concomitant reading training, the current and the previous 2 studies in children with dyslexia^{36,37} stimulated the left temporal area and showed gains at reading tasks. An imaging study with functional magnetic resonance demonstrated improvement in the reading process after transcranial direct current stimulation.³⁸ The authors reported greater connectivity in the left occipital cortex and decreased connectivity in the right occipitotemporal cortex after the stimulation, with the anode placed between T7 and TP7 and cathode in the contralateral region in an individual with alexia.

Although only nonwords and words in text tasks presented significant differences after the intervention, the effect size of other tasks deserve to be mentioned, considering features of

this study and possible clinical implications. We failed to find statistically significant differences for letter and syllable tasks. The 2 studies to date on transcranial direct current stimulation and reading performance in children with dyslexia did not include similar tasks.^{36,37} At the individual level analysis (see Table 2), we noticed a pattern of improvement among younger individuals (12 years or younger) in the letter and syllable tasks. Given the simpler complexity of these tasks, we assume that older individuals with more years of school have already acquired competence and a certain level of proficiency, especially at the letter task. Hence, the impact of transcranial direct current stimulation should be tested in bigger samples, especially considering the results for total number of correct answers in the syllable tasks (.57, a medium effect size).

Regarding the safety of transcranial direct current stimulation in children, adverse effects reported in this study were mild and transient, as previously observed in the studies of Andrade et al and Gillick et al.⁴⁴ Recently, Palm et al⁴⁵ conducted a meta-analysis discussing the therapeutic use of transcranial direct current stimulation in children and adolescents, suggesting that transcranial direct current stimulation seems to be a safe, tolerable, and powerful in the pediatric population, though this still requires further study to fully ensure the safety of the method. Our results corroborate the overall safety of this neuromodulation technique for the treatment of children.

Our study has limitations that should be addressed. First, we lacked a control group. In the population that included our potential participants, we conducted a survey before finishing the study protocol and identified that parents were not willing to participate in a long-term study where they might receive the placebo treatment. The families in this study were looking for new treatments to improve their children's reading abilities and were interested in volunteering only if they would receive an

active stimulation. Even the prospect of a crossover design was unwelcomed by the majority of parents surveyed. Thus, we opted to conduct a one-group pretest–posttest design. Ours, however, is not the only transcranial direct current stimulation study intervention to not include a control group.⁵³

We had a small number of participants, although our sample size was similar to previous studies with transcranial direct current stimulation.^{36,37} Age and grade ranges were broad in our study, which hinders our ability to adequately explain the developmental differences in reading skills. Although dyslexia is a relatively common disorder, the design of transcranial direct current stimulation studies with multiple sections poses challenges to enroll a large number of participants, especially at school age. This was true for our study as we had planned a larger sample size but could not achieve recruitment goals. We believe, however, that our results are valuable to provide additional evidence on the potential benefits of the technique, as well as safety information for the pediatric population. Studies using transcranial direct current stimulation in children with dyslexia remain scarce and are in demand. Larger sample sizes⁵⁴ and randomized control trial designs are clearly needed in future studies with this population.

The variability of findings in functional neuroimaging indicates that location of target brain regions varies among participants,^{55,56} which may explain variability of findings among similar electrodes' montage. In this study, the anode electrode was placed between T3 and T5, in accordance with the theoretical location of structures involved in typical reading development. Dyslexia is a heterogeneous condition and studies have shown variability in location of neuroanatomical abnormalities in the human brain.⁴³ All participants in the current study were right handed and most likely had the left hemisphere-dominant for reading, which guided our choice for the placement of the anode on the left side. Ideally, future transcranial direct current stimulation research should use individualized protocols based on results of neurofunctional studies, costs permitting.

Finally, although the results indicate an improvement in reading efficiency for some tasks in children with dyslexia, the gains from transcranial direct current stimulation may not necessarily translate into improved functionality in uncontrolled environments, such as the classroom. Significant results do not necessarily mean clinical or subjective perception of improvement. Future controlled clinical trials must assess clinical relevance of similar results over time.

Conclusion

In summary, the use of transcranial direct current stimulation in children and adolescents with dyslexia appears to improve reading scores of nonwords and words in text. Our findings are encouraging to continue the exploration of the potential benefits of using transcranial direct current stimulation intervention to improve reading skills in youth with dyslexia.

Author Contributions

DMR contributed to conception and design; acquisition, analysis, and interpretation of data; and drafted and critically revised the manuscript. IDB contributed to data analysis, interpretation, and drafted the manuscript. FQC contributed to data analysis and interpretation, and critically revised the manuscript. DdCV contributed to data analysis and drafted the manuscript. RL contributed to conception and design, interpretation of results, and critically revised the manuscript. All authors gave final approval and agree to be accountable for all aspects of work ensuring integrity and accuracy.

Declaration of Conflicting Interests

The authors declared no potential conflicts of interest with respect to the research, authorship, and/or publication of this article.

Funding

The authors received no financial support for the research, authorship, and/or publication of this article.

Ethical Approval

This study was approved by the institutional review board of the Professor Edgard Santos Teaching Hospital, Salvador-Bahia, Brazil (#796461).

References

1. Ferrer E, Shaywitz BA, Holahan JM, Marchione K, Shaywitz SE. Uncoupling of reading and IQ over time: empirical evidence for a definition of dyslexia. *Psychol Sci*. 2010;21(1):93-101.
2. Shaywitz SE, Shaywitz BA, Fletcher JM, Escobar MD. Prevalence of reading disability in boys and girls. Results of the Connecticut Longitudinal Study. *JAMA*. 1990;264(8):998-1002.
3. Peterson RL, Pennington BF. Developmental dyslexia. *Lancet*. 2012;379(9830):1997-2007.
4. Kere J. The molecular genetics and neurobiology of developmental dyslexia as model of a complex phenotype. *Biochem Biophys Res Commun*. 2014;452(2):236-243.
5. Veerappa AM, Saldanha M, Padakannaya P, Ramachandra NB. Genome-wide copy number scan identifies disruption of PCDH11X in developmental dyslexia. *Am J Med Genet B Neuropsychiatr Genet*. 2013;162B(8):889-897.
6. Eicher JD, Powers NR, Miller LL, et al. Genome-wide association study of shared components of reading disability and language impairment. *Genes Brain Behav*. 2013;12(8):792-801.
7. Eicher JD, Montgomery AM, Akshoomoff N, et al. Dyslexia and language impairment associated genetic markers influence cortical thickness and white matter in typically developing children. *Brain Imaging Behav*. 2016;10(1):272-282.
8. Elnakib A, Soliman A, Nitzken M, Casanova MF, Gimel'farb G, El-Baz A. Magnetic resonance imaging findings for dyslexia: a review. *J Biomed Nanotechnol*. 2014;10(10):2778-805.
9. Krasowicz-Kupis G, Borkowska AR, Pietras I. Rapid automatized naming, phonology and dyslexia in Polish children. *Med Sci Monit*. 2009;15(9):460-469.
10. Serniclaes W, Collet G, Sprenger-Charolles L. Review of neural rehabilitation programs for dyslexia: how can an allophonic system be changed into a phonemic one? *Front Psychol*. 2015;6:190.

11. Fusco N, Germano GD, Capellini SA. Efficacy of a perceptual and visual-motor skill intervention program for students with dyslexia. *Codas*. 2015;27(2):128-134.
12. Pape-Neumann J, Ermingen-Marbach MV, Grande M, Willmes K, Heim S. The role of phonological awareness in treatments of dyslexic primary school children. *Acta Neurobiol Exp (Wars)*. 2015;75(1):80-106.
13. Fostick L, Eshcoly R, Shtibelman H, Nehemia R, Levi H. Efficacy of temporal processing training to improve phonological awareness among dyslexic and normal reading students. *J Exp Psychol Hum Percept Perform*. 2014;40(5):1799-1807
14. Ylinen S, Kujala T. Neuroscience illuminating the influence of auditory or phonological intervention on language-related deficits. *Front Psychol*. 2015;6:137.
15. Suarez-Coalla P, Cuetos F. Reading difficulties in Spanish adults with dyslexia. *Ann Dyslexia*. 2015;65(1):33-51.
16. Nergard-Nilssen T, Hulme C. Developmental dyslexia in adults: behavioural manifestations and cognitive correlates. *Dyslexia*. 2014;20(3):191-207.
17. Saba G, Moukheiber A, Pelissolo A. Transcranial cortical stimulation in the treatment of obsessive-compulsive disorders: efficacy studies. *Curr Psychiatry Rep*. 2015;17(5):36.
18. Koops S, Van den Brink H, Sommer IE. Transcranial direct current stimulation as a treatment for auditory hallucinations. *Front Psychol*. 2015;6:244.
19. Batista EK, Klauss J, Fregni F, Nitsche MA, Nakamura-Palacios EM. A randomized placebo-controlled trial of targeted prefrontal cortex modulation with bilateral tDCS in patients with crack-cocaine dependence. *Int J Neuropsychopharmacol*. 2015;18(12):1-11.
20. Shahar H, Alyagon U, Shalev H, Zangen A. Deep Transcranial Magnetic Stimulation over the right prefrontal cortex improves ADHD symptoms: a combined TMS-EEG study. *Brain Stimulation*. 2014;7(5):23.
21. Krause B, Cohen Kadosh R. Can transcranial electrical stimulation improve learning difficulties in atypical brain development? A future possibility for cognitive training. *Dev Cogn Neurosci*. 2013;6:176-194.
22. Nowak DA, Grefkes C, Ameli M, Fink GR. Interhemispheric competition after stroke: brain stimulation to enhance recovery of function of the affected hand. *Neurorehabil Neural Repair*. 2009;23(7):641-656.
23. Kang EK, Baek MJ, Kim S, Paik NJ. Non-invasive cortical stimulation improves post-stroke attention decline. *Restor Neurol Neurosci*. 2009;27(6):645-650.
24. Bandeira ID, Guimaraes RS, Jagersbacher JG, et al. Transcranial direct current stimulation in children and adolescents with attention-deficit/hyperactivity disorder (ADHD): a pilot study. *J Child Neurol*. 2016;31(7):918-934.
25. Wu D, Wang J, Yuan Y. Effects of transcranial direct current stimulation on naming and cortical excitability in stroke patients with aphasia. *Neurosci Lett*. 2015;589:115-120.
26. Stagg CJ, Nitsche MA. Physiological basis of transcranial direct current stimulation. *Neuroscientist*. 2011;17(1):37-53.
27. Auvichayapat N, Rotenberg A, Gersner R, et al. Transcranial direct current stimulation for treatment of refractory childhood focal epilepsy. *Brain Stimul*. 2013;6(4):696-700.
28. Duarte N de A, Grecco LA, Galli M, et al. Effect of transcranial direct-current stimulation combined with treadmill training on balance and functional performance in children with cerebral palsy: a double-blind randomized controlled trial. *PLoS One*. 2014;9(8):1-8.
29. Amatachaya A, Auvichayapat N, Patjanasontorn N, et al. Effect of anodal transcranial direct stimulation on autism: a randomized double-blind crossover trial. *Behav Neurol*. 2014;2014:1-7.
30. Bhanpuri NH, Bertucco M, Young SJ, et al. Multiday transcranial direct current stimulation causes clinically insignificant changes in childhood dystonia: a pilot study. *J Child Neurol*. 2015;30(12):1604-1615.
31. Pope PA, Brenton JW, Miall RC. Task-specific facilitation of cognition by anodal transcranial direct current stimulation of the prefrontal cortex. *Cereb Cortex*. 2015;25(11):4551-4558.
32. Shah PP, Szaflarski JP, Allendorfer J, Hamilton RH. Induction of neuroplasticity and recovery in post-stroke aphasia by non-invasive brain stimulation. *Front Hum Neurosci*. 2013;7:888.
33. Thomson JM, Doruk D, Mascio B, Fregni F, Cerruti C. Transcranial direct current stimulation modulates efficiency of reading processes. *Front Hum Neurosci*. 2015;9:114.
34. Heth I, Lavidor M. Improved reading measures in adults with dyslexia following transcranial direct current stimulation treatment. *Neuropsychologia*. 2015;70:107-113.
35. Turkeltaub PE, Benson J, Hamilton RH, Datta A, Bikson M, Coslett HB. Left lateralizing transcranial direct current stimulation improves reading efficiency. *Brain Stimul*. 2012;5(3):201-207.
36. Costanzo F, Varuzza C, Rossi S, et al. Reading changes in children and adolescents with dyslexia after transcranial direct current stimulation. *Neuroreport*. 2016;27(5):295-300.
37. Costanzo F, Varuzza C, Rossi S, et al. Evidence for reading improvement following tDCS treatment in children and adolescents with Dyslexia. *Restor Neurol Neurosci*. 2016;34(2):215-226.
38. Lacey EH, Jiang X, Friedman RB, et al. Transcranial direct current stimulation for pure alexia: effects on brain and behavior. *Brain Stimul*. 2015;8(2):305-307.
39. Mello CBd, Argollo N, Shayer BPM, et al. Versão abreviada do WISC-III: correlação entre QI estimado e QI total em crianças brasileiras [in Portugal]. *Psicologia: Teoria e Pesquisa (Portuguese)*. 2011;27:149-155.
40. Capellini SA, Oliveira AM, Cuetos F. *PROLEC: Provas de avaliação dos processos de leitura*. 3rd ed. São Paulo (SP), Brazil: Casa do Psicólogo; 2014.
41. Moojen S, Lamprecht R, Santos RM, et al. *CONFAS—Consciência fonológica instrumento de avaliação sequencial*. 4th ed. São Paulo (SP), Brazil: Casa do Psicólogo; 2015.
42. Mattai A, Miller R, Weisinger B, et al. Tolerability of transcranial direct current stimulation in childhood-onset schizophrenia. *Brain Stimul*. 2011;4(4):275-280.
43. Zoubinetzky R, Bielle F, Valdois S. New insights on developmental dyslexia subtypes: heterogeneity of mixed reading profiles. *PLoS One*. 2014;9(6):1-15.

44. Gillick BT, Kirton A, Carmel JB, Minhas P, Bikson M. Pediatric stroke and transcranial direct current stimulation: methods for rational individualized dose optimization. *Front Hum Neurosci*. 2014;8:739.
45. Palm U, Segmiller FM, Epple AN, et al. Transcranial direct current stimulation in children and adolescents: a comprehensive review. *J Neural Transm (Vienna)*. 2016;123(10):1219-1234.
46. Andrade AC, Magnavita GM, Allegro JV, Neto CE, Lucena Rde C, Fregni F. Feasibility of transcranial direct current stimulation use in children aged 5 to 12 years. *J Child Neurol*. 2014;29(10):1360-1365.
47. Bortoletto M, Pellicciari MC, Rodella C, Miniussi C. The interaction with task-induced activity is more important than polarization: a tDCS study. *Brain Stimul*. 2015;8(2):269-76.
48. International Business Machines. IBM SPSSstatistics for windows, version 21.0. Armonk, NY: IBM Corp. 2012. Accessed March 13, 2018.
49. Faul F, Erdfelder E, Lang A, Buchner A. G*Power 3: a flexible statistical power analysis program for the social, behavioral, and biomedical sciences. *Behav Res Methods*. 2007;39(2):175-191.
50. Morris SB, DeShon RP. Combining effect size estimates in meta-analysis with repeated measures and independent-groups designs. *Psychol Methods*. 2002;7:105-125.
51. Loureiro LMJ, Gameiro MGH. Interpretação crítica dos resultados estatísticos: para lá da significância estatística [in Portugal]. *Revista de Enfermagem Referência (Portuguese)*. 2011;3:151-162.
52. Espírito-Santo H, Daniel F. Calcular e apresentar tamanhos do efeito em trabalhos científicos (1): As limitações do $p < 0,05$ na análise de diferenças de médias de dois grupos [in Portugal]. *Revista Portuguesa de Investigação Comportamental e Social (Portuguese)*. 2015;1(1):3-16.
53. Auvichayapat P, Aree-Uea B, Auvichayapat N, et al. Transient changes in brain metabolites after transcranial direct current stimulation in spastic cerebral palsy: a pilot study. *Front Neurol*. 2017;8:366.
54. Gillick B, Rich T, Nemanich S, et al. Transcranial direct current stimulation and constraint-induced therapy in cerebral palsy: a randomized, blinded, sham-controlled clinical trial. *Eur J Paediatr Neurol*. 2018;22(3):358-368.
55. Muller-Axt C, Anwander A, von Kriegstein K. Altered structural connectivity of the left visual thalamus in developmental dyslexia. *Curr Biol*. 2017;27(23):3692-3698.
56. Cao F, Yan X, Wang Z, et al. Neural signatures of phonological deficits in Chinese developmental dyslexia. *Neuroimage*. 2017;146:301-311.