



Since January 2020 Elsevier has created a COVID-19 resource centre with free information in English and Mandarin on the novel coronavirus COVID-19. The COVID-19 resource centre is hosted on Elsevier Connect, the company's public news and information website.

Elsevier hereby grants permission to make all its COVID-19-related research that is available on the COVID-19 resource centre - including this research content - immediately available in PubMed Central and other publicly funded repositories, such as the WHO COVID database with rights for unrestricted research re-use and analyses in any form or by any means with acknowledgement of the original source. These permissions are granted for free by Elsevier for as long as the COVID-19 resource centre remains active.

Chapter 3

Replication and Expression Strategies of Viruses

Sephra Rampersad¹ and Paula Tennant²

¹The University of the West Indies, St. Augustine, Trinidad and Tobago, ²The University of the West Indies, Mona, Jamaica

Nature's stern discipline enjoins mutual help at least as often as warfare

Theodosius Dobzhansky

One of the key features of viruses is their reliance on living cells for replication and propagation. On their own, viruses lack the complete machinery necessary for many life-sustaining functions. Infection of a host cell and viral propagation are dependent on the transcription of viral mRNA, and in turn, translation of viral proteins as well as genome replication. Specifically, viruses depend on host cells for: (1) energy, mainly in the form of nucleoside triphosphates, for polymerization involved in genome and viral protein synthesis; (2) a protein-synthesizing system for synthesis of viral proteins from viral mRNAs (some viruses also require host enzymes for posttranslational modification of their proteins; e.g. glycosylation); (3) nucleic acid synthesis, for although some viruses code for an enzyme or enzymes involved in the synthesis of their nucleic acids, they do not usually contribute all the polypeptides involved and are reliant on various host factors; and (4) structural components of the cell, in particular lipid membranes, involved in virus replication.

Even though the dependence on host cell functions varies between virus groups and largely relates to genome complexity, nowhere in the biosphere is genome replication accomplished with greater economy and simplicity than among viruses. Viral genomes carry out multiple functions serving as mRNAs for translation in some instances and/or templates for genome transcription and replication. Accordingly, viral genomes contain regulatory RNA elements that promote, regulate, and coordinate these molecular processes. The central role played by viral genomes is frequently executed by

viral or host cell proteins that interact with these genomes, but other partners include other RNA molecules (e.g., cellular tRNA primer that initiates reverse transcription of the retroviral RNA genome). Together, protein and RNA factors interact with cellular pathways to allow viruses to successfully hijack and customize the host cell machinery for virus production. As a result, viruses and their hosts have been involved in a long-standing battle of adaptation and counter-adaptation for gene expression and nucleic acid synthesis.

In this chapter, we address genome replication strategies including the diverse strategies that exploit the biology of the hosts, control gene expression, and ensure preferential propagation of the virus. The other phases of virus replication are discussed in Chapter 10, Host–Virus Interactions: Battles Between Viruses and Their Hosts. Work with bacteriophages identified the essential phases of virus replication. The process, beginning with entry of the virus into the host cell to the release of progeny viruses, is referred to as the replication cycle. The replication cycle of all viruses involves three key phases: initiation of infection, genome replication and expression, and finally, egress or release of mature virions from the infected cell.

OVERVIEW OF VIRUS GENOME TRANSCRIPTION AND REPLICATION

From the perspective of the virus, the purpose of viral replication is to allow production and survival of its kind. By generating abundant copies of its genome and packaging these copies into virions, the virus is able to continue infecting new hosts. All viruses must therefore express their genes as functional mRNAs early in infection in order to direct the cellular translational machinery to synthesize viral proteins. The pathways leading from genome to message vary among different viruses (Fig. 3.1). As shown in Chapter 2, Virion Structure, Genome Organization, and Taxonomy of Viruses, viral genomes are quite different from cellular genomes, which consist uniformly of dsDNA. Viral genomes provide examples of almost every structural variation imaginable. There are four main categories of viral genomes: dsDNA, ssDNA, dsRNA, and ssRNA. These categories are further divided on the basis of distinct modes of transcription. For some RNA viruses, the infecting genome acts as mRNA. For other RNA and DNA viruses, viral mRNA is synthesized upon entry into the host cell.

RNA viruses replicate their genomes via one of two unique pathways—either by RNA-dependent RNA synthesis, or among the retroviruses, by RNA-dependent DNA synthesis (reverse transcription) followed by DNA replication and transcription. Both pathways require enzymatic activities that are not usually found in uninfected host cells and as a result, these viruses code for the requisite enzymes, which are either expressed early in infection

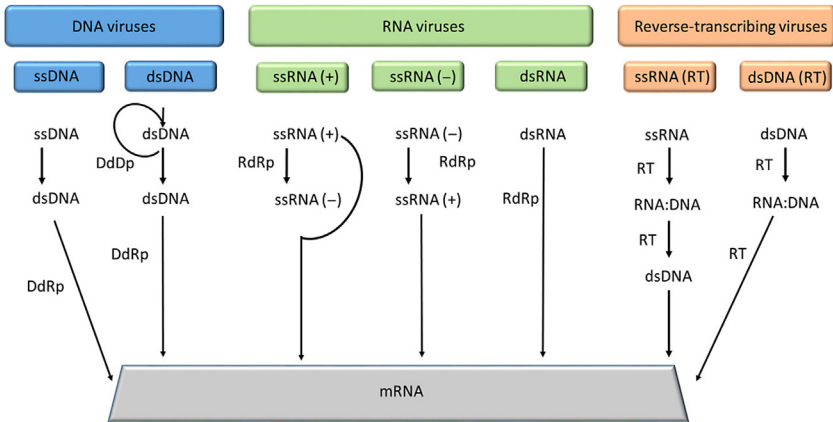

FIGURE 3.1 Summary of replication and transcription modes of different classes of viruses. DdDp, DNA-dependent DNA polymerase; DdRp, DNA-dependent RNA polymerase; RdRp, RNA-dependent RNA polymerase; RT, reverse transcriptase. The ssRNA(+) can serve as the template for translation and does not undergo any modification prior to translation.

or they are copackaged with the viral genome during the assembly of virions in preparation for the next round of infection. Note that the process of synthesizing RNA complementary to an RNA template is often called “*transcription*,” and differs from the conventional definition of transcription where DNA is used as template for mRNA synthesis.

Double-stranded RNA viruses carry their own RNA synthesizing enzymes within their virions. Once inside a cell, the enzymes transcribe one of the RNA strands of the dsRNA genome to ssRNA(+) within the virion, which upon release into the cytoplasm (through channels in the virion) is translated by the host cell machinery. In addition, these ssRNA(+) can act as a template for (-) RNA strand synthesis that is converted back into a dsRNA genome for packaging. Whereas DNA viruses need only to generate mRNA, these RNA viruses without a DNA stage have to synthesize both viral RNA and mRNA. The viral RNA is generated through a replication intermediate, referred to as the “*antigenome*” or “*minus*” (-) strand, which serves as a template for viral RNA synthesis. Single-stranded RNA genomes, however, exist in two forms: either the sense or the “*plus*” (+) strand or the nonsense or “*minus*” (-) strand. ssRNA(+) genomes act as mRNA, are infectious upon entry into host cells, and are immediately translated into protein, including the enzymes required for viral reproduction. On the other hand, (-) RNA, which is not mRNA, requires a virus-encoded RNA-replicating enzyme that is carried within the virion, to copy (-) RNA to monocistronic (+) RNA that is recognized by the host cell translation machinery. The enzyme also synthesizes viral (progeny) genome using the (+) RNA as template. The other class of (+) RNA viruses is the retroviruses. Here, the virion

carries an enzyme that converts the ssRNA(+) into dsDNA upon infection. The virus genome integrates into the host genome and can be passed from parent to offspring should integration occur in germline cells. The integrated virus genome, referred to as a provirus, is transcribed as a cellular gene (some may require splicing) and translated by the cellular synthesis machinery on export to the cytoplasm. Some full-length ssRNA(+) transcripts are packaged into new retrovirus virions. It should be noted that in all these examples, the balance between the processes of transcription and genome replication must be properly maintained to allow efficient viral proliferation. It appears that the transition occurs by the (1) action of *trans*-acting proteins that are either absent, or at low levels in virions, but which accumulate over the course of infection; (2) regulatory role of promoter RNA secondary structure along with the action of specific viral (e.g., capsid) and host cellular factors; (3) alteration of the virus RNA synthesizing enzyme complex that changes its role as “*transcriptase*” to a “*replicase*”; or (4) a combination of the above.

DNA viruses need only to generate mRNA and thus replication involves strategies that are familiar in cell biology: transcription of mRNA from dsDNA and replication of dsDNA within the cell nucleus. Many use host enzymes for these processes, while some larger viruses code for their own enzymes. ssDNA viruses, however, first convert their ssDNA to dsDNA intermediates (using host cell DNA enzymes), which are then transcribed into mRNA. Cellular splicing machinery typically generates mature viral mRNAs. The switch from transcription to replication, that is the switch from antigenome production to genomic nucleic acid for packaging, is highly regulated, and unlike RNA viruses, there is the strict demarcation with respect to timing of genomic DNA replication. Early genes, which code for catalytic (e.g., polymerase) and regulatory proteins, are transcribed prior to the initiation of viral DNA replication. Late genes that code for the structural components of the capsid and envelope are transcribed only after viral DNA replication.

POLYMERASES

As indicated earlier, some viruses encode and/or carry the enzymatic repertoire required for genome replication and/or transcription, while others recruit host polymerases. Large DNA viruses, for example, members of *Herpesviridae*, *Adenoviridae*, and *Poxviridae*, and giant viruses, are among those viruses that encode most of their own proteins for replication. Proteins encoded by these viruses are those involved in recognition of the origin of replication, DNA-binding proteins, helicases and primases, DNA polymerase and accessory proteins, exonucleases, thymidine kinase, and dUTPase. Small DNA viruses, for example, *Papillomaviridae*, *Polyomaviridae*, and *Parvoviridae*, do not encode the entire repertoire of proteins required for viral replication because of their limited genome size. They do, however, encode proteins that usurp and control cellular activities. Viruses that do not

replicate in the nucleus and do not have access to host polymerases, typically encode their own polymerases for replication.

The four main types of polymerases used by viruses depend on their genomic constitution and site of replication, that is, nucleus or cytoplasm, and include: **RNA-dependent RNA polymerases (RdRps)**, RNA-dependent DNA polymerases, DNA-dependent RNA polymerases, and DNA-dependent RNA polymerases. DNA viruses replicate their genomes using DNA polymerase enzymes and transcribe their mRNA using DNA-dependent RNA polymerase enzymes. Both (+) and (-) ssRNA viruses replicate and transcribe their genomes using RdRp enzymes (Fig. 3.1). **Reverse transcriptase (RT)** is the enzyme used to produce DNA from RNA templates, and viruses that replicate via an RNA intermediate require this enzyme. RT is virus-encoded as the host cell does not require this enzyme for its nuclear metabolism.

Although high fidelity of virus genome replication is crucial for the long-term survival of viruses, some polymerases are less faithful than others when incorporating the correct nucleotide during replication. The rate by which mutations occur is universally determined as the number of nucleotide substitutions per base per generation. DNA viruses experience low mutation rates. Their DNA polymerase has an error rate of approximately 10^{-6} to 10^{-8} mutations per base pair per generation. This is because of the proofreading ability of the polymerase. A 3' to 5' proofreading exonuclease domain is intrinsic to most DNA polymerases. It allows the enzyme to verify each inserted nucleotide during DNA synthesis and excise mismatched nucleotides in a 3' to 5' direction. With the exception of nidoviruses, the replicative enzymes of RNA viruses (RdRps) lack proofreading ability and these viruses exhibit the highest mutation rates. RNA viruses possess an error rate of approximately 10^{-4} to 10^{-6} mutations per base pair per generation. Not all mutations generated will persist in a virus population, however. Mutations may be neutral or silent (because of genetic code redundancy) and those that interfere with viral replicative mechanisms are eliminated from the viral population. Mutations that do not affect essential viral functions may persist and eventually become fixed within the viral population (see Chapter 4: Origins and Evolution of Viruses).

Initiation, Elongation, and Termination

Unlike cellular DNA and RNA polymerases, which require oligonucleotides to initiate nucleic acid synthesis, viral polymerases initiate genome replication using a variety of mechanisms, that presumably reflect their adaptation to the host cell. Nucleic acid synthesis by polymerases is divided into three phases: initiation, elongation, and termination. Both virus genome transcription and mRNA synthesis occur in three stages.

Initiation

During initiation, the polymerase machinery is recruited to the viral promoter and synthesis begins at or near the 3' end of the template. Two different start sites are used in the synthesis of mRNA and viral genome RNA in a primer-independent (*de novo*), or a primer-dependent mechanism. Primer-dependent initiation requires either an oligonucleotide primer or a protein primer, to provide the initial 3'-hydroxyl for addition of the first incoming nucleotide. In *de novo* initiation, a nucleoside triphosphate, sometimes referred to as the one-nucleotide primer, provides the 3'-hydroxyl for the addition of the next nucleotide. Structures in the polymerase or conformational changes apparently contribute to the process. *De novo* initiation is used by RNA viruses, including those with genomes of positive, negative, ambisense, and dsRNA. Unlike DNA polymerases, most RNA polymerases do not require primers.

After initiation of viral mRNA transcription, DNA viruses and some dsRNA viruses (e.g., reoviruses) acquire a 5'-terminal cap structure (m⁷Gppp[5']N-; where N is the first nucleotides of the nascent RNA) using host enzymes. Most ssRNA(+) viruses (e.g., flaviviruses and nidoviruses) encode their own capping enzymes and some unsegmented ssRNA(-) viruses (including Rabies virus (*Rabies lyssavirus*), measles virus (*Paramyxoviridae*), and Ebola virus (*Filoviridae*)) are capped by their polymerase. Another capping mechanism used by negative-sense RNA viruses (e.g., influenza viruses) is that of “*cap snatching*” from nascent host pre-mRNAs (see later).

Elongation

Once viral genome replication factors and the template are assembled into a complex, the polymerase synthesizes a new complementary strand, without dissociation from the template, and by the repeated addition of a nucleoside monophosphate to the 3' end of the growing RNA strand. Poliovirus RdRp, for example, adds about 5000 nucleotides and so in a single-binding event it can synthesize the entire genome.

Termination

Termination leads to the release of the newly synthesized RNA strand and the dissociation of the polymerase from the template. Transcription termination involves secondary structure mechanisms or in eukaryotic cells, RNA signals direct polyadenylation and termination. Unlike polyadenylation of host mRNAs, which is carried out by a specific poly(A) polymerase, polyadenylation of viral mRNAs is catalyzed by the viral polymerase. In nonsegmented negative RNA viruses, obligatory sequential transcription dictates that termination of each upstream gene is required for initiation of

downstream genes. Therefore, termination is a means of regulating expression of individual genes within the framework of a single transcriptional promoter.

MECHANISMS OF GENOME TRANSCRIPTION AND REPLICATION

The diversity in mechanisms used by polymerases to replicate and/or transcribe viral genomes is summarized in the following section. As will be seen, the mechanisms are dictated by the nature and structure of the viral genomes.

Rolling Circle Replication

Rolling circle replication (RCR) is important to circular ssDNA genome replication (e.g., Φ X174 phage and geminiviruses). The DNA polymerase involved must exhibit a high level of processivity and strand displacement characteristics. Upon infection, a complementary strand designated as the (–) strand is generated by host enzymes from the virus' ssDNA genome that is referred to as the (+) strand. A duplex or replicative form (RF) results. Subsequently, a viral endonuclease enzyme (Rep protein) produces a nick in the (+) strand of the RF, exposing a free 3' end and a free 5' end. DNA synthesis begins by addition of deoxyribonucleotides by DNA polymerase to the free 3' end of the (+) strand using the (–) strand as template. The (–) strand revolves while serving as template hence the name rolling circle. The addition of nucleotides displaces the free 5' end outward in the form of a free tail. Once the entire (–) strand template is copied, the (+) strand tail is cut into correct genome lengths by an endonuclease to provide many copies of free, linear DNA molecules. The latter are eventually by joined DNA ligase to form closed, circular ssDNA molecules. The RF can be used to generate mRNA for the manufacture viral proteins. The RCR mechanism is also thought to be important in the replication of dsDNA viruses such as herpesviruses (Fig. 3.2). Here, multiple cycles of continuous copying of a circular template, followed by discontinuous DNA synthesis on the displaced strand template produces linear dsDNA molecules containing multiple copies of the genome (concatemers).

Rolling-Hairpin Replication

Non-circular genomes may also replicate using an RC-like mechanism, that is, a variation of RCR named rolling-hairpin replication. Linear ssDNA adenovirus-associated viruses (AAVs) are an example. AAVs encode the Rep78 protein that contains amino acid sequence motifs similar to RCR initiator proteins. These viruses contain secondary structures at the ends of their DNA called inverted terminal repeats (ITRs). ITRs are seen as terminal hairpin structures. These ITR regions interact with the viral-encoded Rep protein

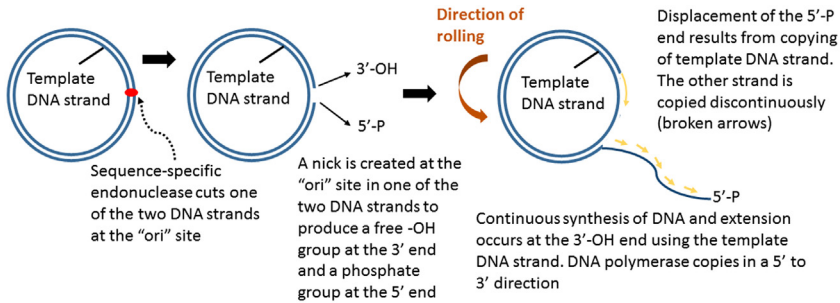

FIGURE 3.2 Rolling circle genome replication. Concatemeric DNA molecules are synthesized from a circular template by a rolling circle mechanism in which nicking of one strand allows the other to be copied continuously multiple times. Discontinuous DNA synthesis on the displaced strand template produces linear dsDNA containing multiple copies of the genome. That is, the dsDNA molecules generated consist of head-to-tail linked genomes. They are eventually cleaved at precise locations to release unit length genomes.

at specific binding sites to initiate replication using the host replication machinery. Rep creates a nick between the hairpin and coding sequences. This creates a free 3'-OH at the 3' ITR that serves as a primer, and DNA synthesis continues to the end of the genome, duplicating the 5'-terminal ITR structure. Refolding of the termini generates the same secondary structures present in the template DNA. The end result is a fully replicated viral genome with the same secondary structures.

dsDNA Bidirectional Replication

This is the classical mode of replication used by eukaryotes and most nuclear dsDNA viruses, including the majority of phages. DNA replication begins at a specific site in the viral genome, called origin of replication, or "ori." Some viruses (e.g., *Human alphaherpesvirus 1*) have multiple "ori" sites. The step-wise assembly of replication initiation complexes at these *ori* sites then occurs followed by recruitment of topoisomerases that unwind dsDNA at each *ori*, and prevents supercoiling and torsional stress of the partially unwound template DNA. ssDNA-binding proteins keep the single strands of DNA separate. A replication fork or bubble is produced. A primase synthesizes short RNA primers that are used by the DNA polymerase to begin DNA synthesis. DNA is synthesized in a 5' to 3' direction. DNA polymerase and several replication-associated factors copy the leading strand at the fork, starting at the 3' end of the primer in a continuous manner. Copying of the lagging strand requires discontinuous DNA synthesis that results in

production of short DNA (Okazaki) fragments, which must then be ligated after the primers are removed by RNase H degradation.

dsDNA (RT) Transcription and Replication

Pararetroviruses (e.g., members of *Caulimoviridae*) are circular, dsDNA viruses that transition through an RNA intermediate (**pregenomic RNA** or pgRNA) in a manner that is reminiscent of retrovirus replication. Replication involves two phases; transcription of the pgRNA from virus DNA in the nucleus followed by reverse transcription in the cytoplasm. In contrast to retroviruses, virus DNA remains episomal and does not integrate into the host genome. Covalently closed virus dsDNA serves as a template for host polymerase transcription and the generation of viral pgRNA. Upon transportation to the cytoplasm, capped and polyadenylated pgRNA is translated to viral proteins including the RT and is also used as template for subsequent reverse transcription catalyzed by virus RT. The resulting dsDNA is either packaged into a new virion or targeted to the nucleus for another round of transcription.

ssRNA (RT) Replication

This mechanism pertains to all members of the family *Retroviridae*. The process takes place in the cytoplasm, after viral entry. Here, the genomic RNA is reverse transcribed into dsDNA. A RNA:DNA duplex is produced, which is then resolved by degradation of the RNA by the virus-encoded RNase H. Only a small stretch of polypurines is resistant to degradation and this serves as a primer to initiate the synthesis of the cDNA. The cDNA, integrated into the host cell's genome, is now referred to as a provirus and undergoes cellular transcription and translational processes to express viral genes. Integration is a key event in the replicative process of all retroviruses. Integration is signaled after the RNA genome of these viruses is reverse transcribed into ds linear, viral DNA. Linear viral DNA contains termini **long terminal repeats** (LTRs) sequences at the 3' and 5' ends, which are specifically recognized by the viral **integrase** (IN) enzyme. In some retroviruses, nuclear localization signals facilitate migration to the nucleus. Depending upon the retrovirus, preintegration complexes either enter the nuclei of non-dividing cells through the **nuclear pore complex** (NPC) (e.g., HIV) or enter when the nuclear membrane dissolves during cell division [e.g. Moloney murine sarcoma virus, (*Murine leukemia virus*)]. Once inside the nucleus and after association with host chromosomes, viral IN catalyzes insertion of viral sequences into the host DNA (**Fig. 3.3**). The LTR sequences at the 3' and 5' ends of the linear viral DNA are joined to the host's DNA in two steps called

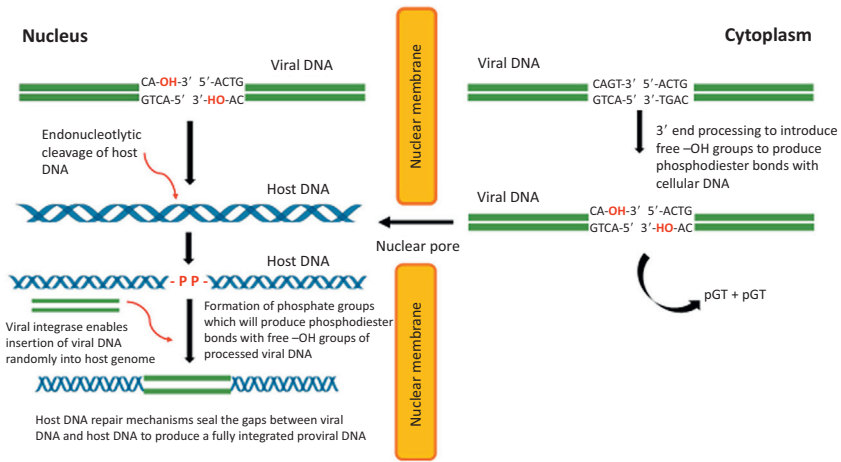

FIGURE 3.3 Integration of viral DNA (e.g., retroviruses) into host's genome. The LTRs of linear viral DNA are joined to the host's DNA in two steps called end-processing and end-joining.

end-processing and end-joining. After successful integration of the viral DNA into the host DNA, cellular repair proteins fill the gap and ligate the DNA ends. Autointegration is prevented by cellular proteins (HMG family of proteins for **H**igh **M**obility **G**roup proteins, and BAF for **B**arrier to **A**utointegration **F**actor). Retroviruses have different target sites of integration; for example, lentivirus DNA insertion occurs preferentially in active transcription units (TUs), whereas *Murine leukemia virus* integrates at or close to promoter regions located at the 5' terminus of CpG and TU islands.

Positive-Strand RNA Virus Replication

This mode of replication occurs in the cell host cytoplasm for all ssRNA(+) viruses. ssRNA(+) molecules serve as templates for replication and transcription. The 5' of the genome may be naked, capped, or covalently linked to a viral protein. The 3' end may be either naked or polyadenylated. The ssRNA(+) strand is translated after viral entry into the host cell. A viral polyprotein is typically produced, which encodes the proteins required for replication. The replication process results in the formation of a dsRNA intermediate that is detected by the immune system. Replication, therefore, occurs in membrane-associated replication factories in an effort to avoid the host's immune defense response. This dsRNA is transcribed into genome length ssRNA(+) and serves as the template for either replication or translation. Many ssRNA(+) viruses produce smaller sections of the original transcribed template strand or subgenomic RNAs (sgRNAs) for the translation

of structural or movement proteins. Depending on the virus, sgRNAs may be generated during internal initiation on a minus-strand RNA template and require an internal promoter or there is the generation of a prematurely terminated minus-strand RNA that is used as template to make the sgRNAs. The third mechanism uses discontinuous RNA synthesis while making the minus-strand RNA templates. This involves template switching of the RNA polymerase and the production of chimeric RNAs consisting of a 5' common leader sequence derived from the 5' terminus of the genomic RNA fused to the “body” of the transcript (i.e., the 3' terminal end). The resulting chimeric sg minus-strand RNA can in turn function as a template for the production of subgenomic positive-strand RNAs. Although most sgRNAs are translated into proteins, other sgRNAs regulate the transition between translation and replication, function as riboregulators of replication or translation, or support RNA–RNA recombination.

Double-Strand RNA Virus Transcription and Replication

The 5' end of the dsRNA viral genome may be naked, capped, or covalently linked to a viral protein. Genomic dsRNA is transcribed into viral mRNA that serves as a template for both translation and genome replication. Translation of this mRNA generates proteins required for replication and viral encapsidation. However, dsRNA is typically detected and cleared by the host's immune response. As such, many dsRNA viruses undergo replication within their icosahedral capsids. The replicating RNA polymerases are located within the capsid and produce mRNA strands that are extruded from the particle. In this way, the viral dsRNA does not enter the cytoplasm and evades the hosts' immune system.

Negative-Strand RNA Virus Transcription and Replication

This mode of replication is employed by all ssRNA(–) viruses genomes, except for deltaviruses. Replication occurs in the cytoplasm. The virus codes for its own RdRp, which converts the (–) stranded RNA into (+) RNA template strands. The (+) RNA serves two roles: (1) as the viral mRNA, which is then translated into viral gene products, and (2) as template to produce more (–) RNA strands. The viral RdRP complex is assumed to be the same for both replication and transcription and can switch off functions as required. The newly synthesized (–) RNA is later encapsidated. Of note, two genome subgroups can be distinguished in this group: nonsegmented and segmented. Viruses with segmented genomes replicate in the nucleus, and the RdRp produces one monocistronic mRNA strand from each genome segment.

dsDNA Template Transcription and Replication

This type of genome template for replication/transcription is observed in all dsDNA viruses that replicate in the nucleus or in the cytoplasm. The mode of transcription is similar to eukaryotic transcriptional events in which the process is divided into three steps: (1) the initiation step, when a transcription initiation complex is assembled at the promoter region located upstream of the transcriptional start site, allowing for the recruitment of the RNA polymerase, (2) the elongation step, in which, the polymerase is recruited to template DNA, is activated by phosphorylation of the carboxy-terminal domain (CTD), and proceeds to transcribe the template DNA to RNA, and (3) the termination step, which involves the recognition of specific signals, including the polyadenylation signal.

VIRAL GENOME EXPRESSION

With few exceptions translation in the host cell begins at the 5' initiation codon, the ribosome ratchets along the mRNA template, incorporating each new amino acid, translocating from one codon to the next up until a termination codon. For productive infection, viruses must then utilize this machinery, and remain both stable and undetected in the cell. As alluded to in the previous sections, many viral transcripts have marked structural differences from cellular mRNAs that preclude translation initiation, such as the absence of a 5' cap structure or the presence of highly structured 5' untranslatable leader regions containing replication and/or packaging signals. Furthermore, while the great majority of cellular mRNAs are monocistronic, viruses must often express multiple proteins from their mRNAs. As a result, viruses have evolved a number of mechanisms to allow translation to be customized to their specific needs.

Straightforward exploitation of the cellular capping machinery is typical of DNA viruses that replicate in the nucleus. Other strategies used by viruses include internal initiation of translation of uncapped RNAs in picornaviruses and their relatives, snatching of capped oligonucleotides from host pre-mRNAs to initiate viral transcription in segmented negative-strand RNA viruses, and recruitment of genes for the conventional, eukaryotic-type capping enzymes that apparently occurred independently in diverse groups of viruses (flaviviruses, reoviridae, poxviruses, asfarviruses, some iridoviruses, phycodnaviruses, mimiviruses, baculoviruses, nudiviruses).

Poly(A) tails, at the 3' end, are associated with poly(A)-binding proteins that stabilize the mRNA in the cytoplasm by protecting the 3' end of the newly synthesized mRNA against exoribonucleolytic degradation. Many ssRNA(+) viruses lack a poly(A) tail, but are still efficiently translated. For instance, flaviviruses (e.g., *Dengue virus*, *West Nile virus*) have a capped RNA genome that contains conserved sequences at the 5' and 3' ends,

allowing for circularization and efficient translation. Other examples that follow the same strategy include rotaviruses, barley yellow dwarf viruses, and possibly *Hepacivirus C* (HCV).

Since eukaryotic cells are not equipped to translate polycistronic mRNA into several individual proteins, DNA viruses overcome this limitation by using the cellular mechanism of splicing of their polycistronic mRNA to monocistronic mRNA. RNA viruses, on the other hand, that mostly replicate in the cytoplasm, do not have access to these host mechanisms and consequently produce monocistronic sgRNAs (e.g., coronaviruses and closteroviruses), use segmented genomes where most segments are monocistronic (e.g., reoviruses and orthomyxoviruses) or translate their polycistronic mRNA into a single large protein (polyprotein) that is subsequently proteolytically cleaved (by viral or host enzymes) into functional individual proteins (e.g., picornaviruses and flaviviruses). However, the use of these mechanisms is not without consequences: (1) some viral proteins may be expressed from sgRNAs but the components of the replication complex that are needed early in infection must still be translated from the genomic RNA, (2) viruses with segmented genomes have to ensure the correct packaging of the different segments, and (3) polyprotein expression represents an inefficient use of host cell resources as all virus proteins are produced in equal amounts, even though catalytic proteins are often required in much smaller quantities than the structural proteins. Alternative and more efficient mechanisms of expressing multiple proteins from a single viral mRNA involve internal ribosome entry, leaky scanning, ribosome shunting, reinitiation, ribosomal frameshifting, and stop codon read-through. In addition, several viruses have evolved proteins and/or RNA structural elements that further enhance translation of the viral mRNAs. Viral gene expression is facilitated by the possession of regulatory signals within viral mRNAs that are recognizable by the host cell. These signals ultimately enable the virus to shut off host gene expression to ensure preferential viral gene expression. The strategies are reviewed in the section that follows.

Disruption of Transcription Initiation Complex Assembly

Transcription can be viewed as a highly regulated 3-phase process: initiation, elongation, and termination. Initiation of transcription requires the recruitment and assembly of a large multiprotein DNA-binding transcription initiation complex. During the course of evolution, several viruses have developed strategies that affect the loading of host transcription initiation factors into transcription complexes, which ultimately shuts down host protein synthesis (Fig. 3.4). Viral mRNA transcripts compete against cellular mRNAs and preferentially gain access to the cellular gene expression machinery.

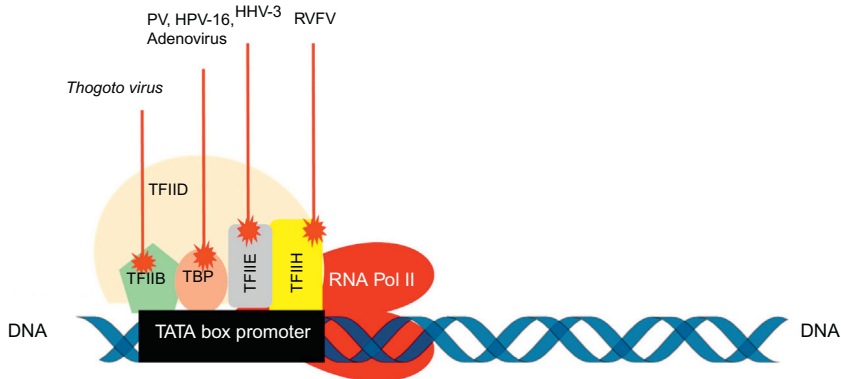

FIGURE 3.4 Different strategies used by viruses to down regulate host transcription. The **TATA** box-binding protein (TBP) is inhibited by HPV-16 E7 protein or by adenovirus E1A protein, and it is cleaved by the poliovirus 3C protease; *Thogoto virus* ML protein interacts with host TFIIB and strongly inhibits IRF3 and NF-kappa-beta-regulated promoters; HHV-3 IE63 targets TFIIE, while *Rift Valley fever phlebovirus* (RVFV) targets TFIIF complex. Viruses: PV, Poliovirus; HPV-16, *Gammacpapillomavirus 16*; HHV-3, *Human alphaherpesvirus 3*.

Termini Maturation and Modification

Elongation and termination of transcription are coupled to end-processing of the mRNA where the 5' cap (added co- or posttranscriptionally) and 3' poly (A) tail are generated on the ends of the mRNA strand. The 5' cap refers to the 7-methylguanosine (m7G) that is added onto the 5' end of mRNA transcript. The processed 5' end is important because the 5' cap is the site for the assembly of the translation initiation complex, and it protects and stabilizes the mRNA strand from 5'-3' exonucleolytic degradation when it is exported out the nucleus and into the cytoplasm for translation. The scanning process to locate the start codon for initiation of translation begins at the 5' end, and the 5' cap sequence allows immune recognition of foreign RNAs (including viral transcripts) as “nonself.” Cap snatching refers to a mechanism used by ssRNA(−) viruses that are incapable of synthesizing their own 5' cap. Cap snatching involves cleavage of a short nucleotide sequence, 10–20 nts in length, from the 5' end of cellular mRNAs (Fig. 3.5). The capping apparatus can be either host- or virus-derived. If virus-encoded, cleavage is carried out by the endonuclease activity of the viral RdRp. Sequence complementarity shared between the nucleotides within the cleavage site of the donor mRNA and the viral RNA facilitates successful cap snatching. Members of the *Arenaviridae* and the *Orthomyxoviridae* families, along with most if not all of those of the order *Bunyvirales*, steal the 5' capped ends of host mRNAs to incorporate this cis-acting stability element into their own transcripts. Recent discoveries indicate that 2'-O-methylation of cap structures is recognized by innate immune interferons to differentiate host versus virus transcripts. The cap-stealing mechanisms used by segmented RNA viruses to generate their mRNAs circumvent this innate detection system.

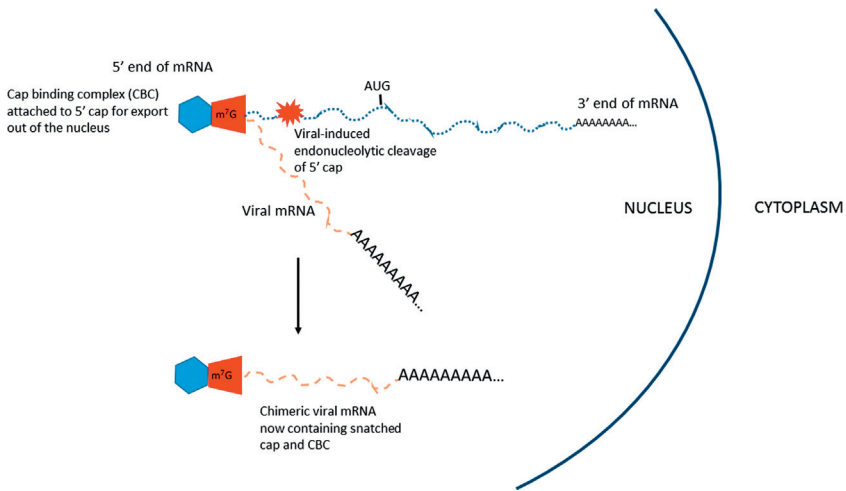

FIGURE 3.5 Cap snatching of cellular mRNA. The mechanism involves cleavage of short fragments from the 5' end of cellular mRNAs and use of these capped fragments for the synthesis of viral mRNAs.

Internal Ribosome Entry

Viral initiation of translation in the absence of a 5' cap requires activation of noncanonical translation mechanisms. An RNA domain, called the **Internal Ribosome Entry Site (IRES)**, enables cap-independent initiation of translation, and can allow initiation of translation at a site not specific to the 5' cap. IRES elements are important to viruses without a 5' cap as they allow ribosome recruitment under conditions where cap-dependent protein synthesis is severely repressed. *Cripavirus* IRES also allows translation initiation on an alanine or glutamine tRNA and not necessarily the methionine tRNA. Downstream hairpin loops are RNA structures that facilitate initiation of cap-dependent translation in the absence of eIF2 translation initiation factors.

In addition, the physiological state of the infected cell dictates whether host mRNA transcripts undergo cap-dependent translation or cap-independent translation. When the cell exhibits normal housekeeping functions, translation of cellular mRNAs is carried out by a cap-dependent mechanism; however, under stressful conditions, such as heat shock, viral infection, hypoxia, and irradiation, the translation mechanism switches from cap dependency to IRES-driven mechanisms. Infection by a range of viruses induces the activation of the ER stress response, resulting in the stimulation of IRES-dependent translation. This switch is widely observed in picornaviruses since their viral mRNA transcripts do not contain the m7G cap at their 5' ends. As such, viruses containing IRES are able to efficiently benefit from the host cells ER stress response for their own multiplication. Inhibition of cap-dependent translation of cellular mRNAs by either viral

infections or stress factors is achieved by (1) specific cleavage of cellular translation initiation factors by HIV and picornaviral proteases, or cellular caspases, (2) active phosphorylation of factors and cofactors of translation, such as eIF2 α , (3) excessive production of the cap-binding protein eIF4E, which interacts with eIF4G and results in the impairment of the eIF4 complex, and (iv) restriction of eIF4E function by activation of microRNAs which, again, disrupts the assembly of the eIF4 complex.

Poly(A) Tailing

Addition of the 3' poly(A) tail is another end-processing mechanism required to protect the mRNA transcript from nucleolytic degradation in the cytoplasm and enable mRNA stability. This is the site of binding of poly(A) binding protein in the cytoplasm. Cellular mRNA transcripts undergo polyadenylation through cleavage at the signal sequence AAUAAA by the CPSF (cleavage and polyadenylation specificity factor) and CSTF (cleavage stimulation factor). Viral mRNAs are synthesized without this signal sequence. Stuttering occurs at a site containing a slippery sequence (mononucleotide repeats) and involves 1-base repeated frameshifts on the mRNA strand (Fig. 3.6). It is a mechanism used by various negative RNA(-) viruses of the families *Bornaviridae*, *Filoviridae*, *Paramyxoviridae*, *Rhabdoviridae*, and

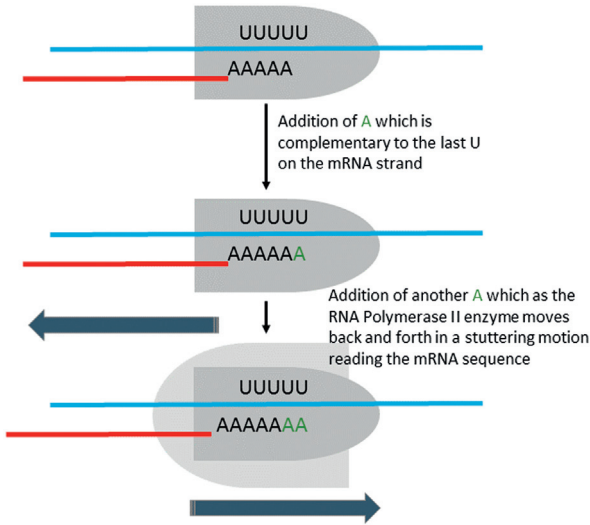

FIGURE 3.6 Stuttering mechanism. Stuttering involves the slippage of RNA polymerase over a stop codon sequence on the cellular mRNA sequence that results in addition of A residues on the viral mRNA strand effectively introducing a poly(A) tail on the viral mRNA. The addition of the 3' poly(A) tail is another end-processing mechanism that protects the mRNA transcript from nucleolytic degradation in the cytoplasm and enables mRNA stability.

Orthomyxoviridae to polyadenylate their mRNAs. The addition of the poly(A) tail to the 3' terminus of mRNA transcripts carries a stretch of five to seven uridine residues located in close proximity to the 5' terminus of the viral RNA template. To achieve this, viral-encoded RdRp remains attached to the 5' terminus of the viral RNA template, resulting in steric hindrance at this site. Upon recognition of the polyadenylation signal, RdRp moves back and forth over this stretch of U residues, reiteratively copies these residues, and produces a stretch of adenines effectively, a poly(A) tail at the 3' end of the viral mRNA.

RNA Editing

This mechanism, also observed in some eukaryotes, allows RNA viruses (except dsRNA viruses) to produce multiple proteins from a single gene. In these viruses, the RNA polymerase reads the same template base more than once, creating insertions or deletions in the mRNA sequence, thereby generating different mRNAs that encode different proteins. There are two kinds of mRNA editing: (1) cotranscriptional editing through polymerase slippage and (2) posttranscriptional editing. RNA editing in members of the *Ebolavirus* genus increases their genome coding capacity by producing multiple transcripts encoding variants of structural and nonstructural glycoproteins from a single gene, ultimately increasing its ability for host adaptation.

Alternative Splicing

Also observed in many cellular organisms, alternative splicing allows production of transcripts having the potential to encode different proteins with different functions from the same gene (Fig. 3.7). The sequence of the mRNA is not changed as with RNA editing; rather the coding capacity is changed as a result of alternative splice sites. Alternative splicing is regulated by cellular and viral proteins that modulate the activity of the splicing factors U1 and U2, both of which are components of the spliceosome. The spliceosome is made up of the snRNAs (small nuclear RNAs) U1, U2, U4, U5, and U6, together with various regulatory factors. Activation of the spliceosome is facilitated by cis-acting signals in the mRNA sequence. Some of these signals include donor splice sites (5' terminus), acceptor splice sites (3' terminus), polypyrimidine tracts, and branch point sites. Serine/arginine-rich proteins, as well as heterogeneous nuclear ribonucleoproteins, play a key role in splice site recognition. Alternative splicing (1) increases the virus' ability to encode several proteins in a given transcript (e.g., adenoviruses and retroviruses can encode ~12 different peptides from one pre-mRNA), (2) is a mechanism to regulate early and late expression for viruses (e.g., papillomaviruses), and (3) splicing is coupled to export of mRNA out of the nucleus. While only mature, spliced mRNA transcripts are exported out of

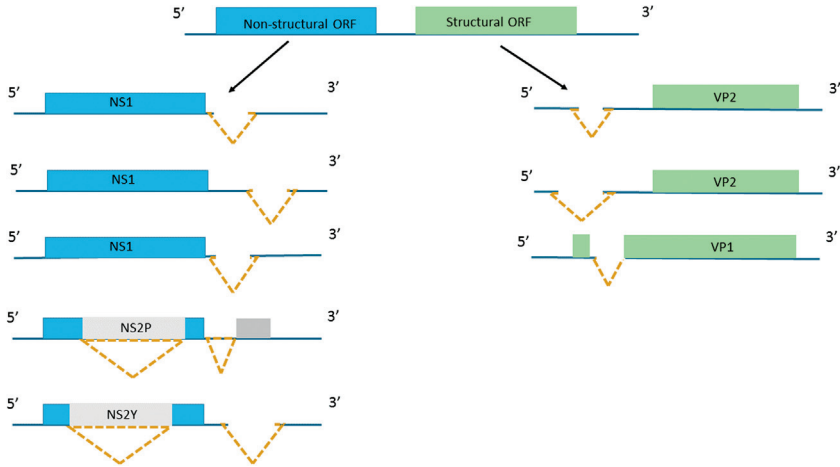

FIGURE 3.7 Alternative splicing. Alternative splicing is common in parvovirus pre-mRNA transcript processing and allows for the generation of different proteins from a specific nucleotide sequence on the viral mRNA strand. *Dotted lines* indicate alternative splice sites.

the nucleus, hepadnaviruses and retroviruses are able to export nonspliced mRNA transcripts out of the nucleus for translation. On the other hand, the NS1 protein (**nonstructural protein 1**) of influenza viruses can interact with multiple host cellular factors via its effector- and RNA-binding domains. It is capable of associating with numerous cellular spliceosome subunits, such as U1 and U6 snRNAs, and can inhibit cellular gene expression by blocking the spliceosome component recruitment and its transition to the active state.

Both conservation and evolution of viral splice site sequences allow for improved adaptation to the host, and ensure recognition by the host’s splicing machinery. Therefore, viruses can induce preferential induction of viral mRNA splicing by the cellular splicing machinery. Knowledge concerning the coordination between cellular and viral genome splicing comes from adenoviruses and retroviruses, but only limited data are available for other viruses, for example, influenza viruses.

Suppression of Termination

This is also referred to as stop codon read-through, and is a programmed cellular and viral-mediated mechanism used to produce C-terminally extended polypeptides, and in viruses, it is often used to express replicases. Termination of translation occurs when one of three stop codons enters the A-site of the small 40S ribosomal subunit. Stop codons are recognized by release factors (eRF1 and eRF3), which promote hydrolysis of the peptidyl-tRNA bond in the peptidyl transferase center (P-site) of the large ribosomal

subunit. Termination is a very efficient mechanism that is tightly controlled by the type of stop codon encountered (UAA, UAG, or UGA). Some termination codons are referred to as “leaky” depending on the nature of the base positioned after the stop codon (e.g., UGAC) where they allow “read through” at frequencies ranging from 0.3% to 5%. Read-through occurs when this leaky stop codon is misread as a sense codon with translation continuing to the next termination codon. Read-through signals and mechanisms of prokaryotic, plant, and mammalian viruses are variable and are still poorly understood.

Programmed Ribosomal Frameshifting

Programmed ribosomal frameshifting is a tightly controlled, programmed strategy used by some viruses to produce different proteins encoded by two or more overlapping open reading frames (Fig. 3.8). Ordinarily, ribosomes function to maintain the reading frame of the mRNA sequence being translated. However, some viral mRNAs carry specific sequence information and structural elements in their mRNA molecules that cause ribosomes to slip, and then readjust the reading frame. The frameshift results from a change in the reading frame by one or more bases in either the 5′ (−1) or 3′ (+1) directions during translation. This ribosomal frameshift enables viruses to encode more proteins in spite of their small size.

Leaky Scanning and Translation Reinitiation

In the world of viruses, this extended mechanism of “modified” translation occurs when the start codon is bypassed by the translation initiation complex during translation, but continuous scanning allows locating another AUG start codon at a downstream site. This occurs because the initiation codon can be part of a weak Kozak consensus sequence. As a result, there can be

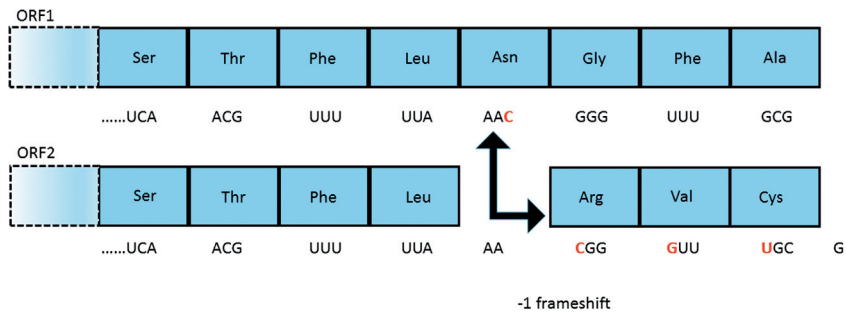

FIGURE 3.8 Ribosomal frameshifting. −1 ribosomal frameshift, common to parvoviruses, changes the amino acids encoded in the mRNA strand by moving the reading frame 1-base down (−1).

the production of several different proteins if the AUG codon is not in frame, or proteins with different N-termini if the AUGs are in the same frame. A number of viruses engage in leaky scanning, including members of the families *Herpesviridae*, *Orthomyxoviridae*, and *Reoviridae*.

Ribosomal Shunting

Ribosomal shunting occurs when the ribosomal initiation complex is loaded onto an mRNA at the 5'-cap but the process of scanning for the start codon progresses for only a short distance, bypasses a large internal leader region, and initiates translation at another start codon located downstream of the leader sequence (Fig. 3.9). It is, therefore, referred to as cap-dependent discontinuous scanning. The mechanism of ribosome shunting has not been described in molecular detail. Shunting expands the coding capacity of mRNAs of viruses such as caulimoviruses.

“2A” Oligopeptides and “Stop-Carry On” Recoding

Production of viral proteins often requires noncanonical decoding events (or “recoding”) on certain codons during translation due to the restricted coding capacity of a small genome size. “2A” oligopeptides coded for by viruses (e.g., *Foot-and-mouth disease virus*, FMDV) are important to “stop-carry on” recoding. 2A oligopeptides interact with the ribosomal exit tunnel to initiate a stop codon-independent termination of translation at the final proline

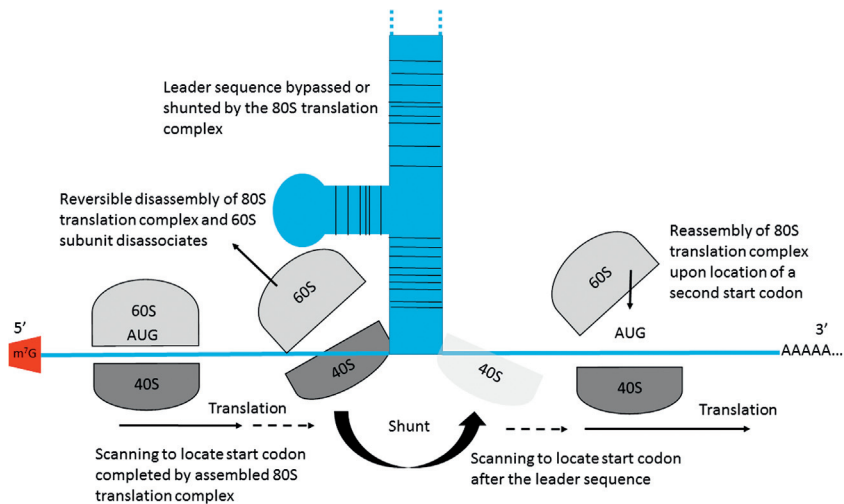

FIGURE 3.9 Ribosomal shunting. Ribosomal shunting by the 80S ribosome involves bypassing the AUG start codon closest to the 5' end of the mRNA sequence to locate a second AUG start codon downstream.

codon of 2A. Ribosomes, therefore, skip the synthesis of the glycyl-prolyl peptide bond at the C-terminus of a 2A peptide (cleavage of the peptide bond between a 2A peptide and its immediate downstream peptide). Translation is then reinitiated on the same codon, which leads to production of two individual proteins from one open reading frame.

SUBVERSION OF HOST GENE EXPRESSION

Viruses not only employ strategies that maximize the coding capacity of their small genomes, disguise their mRNA with the same structural elements found in host mRNA, regulate their genome expression in a time- and space-dependent manner, but they have also evolved ways of subverting host cell functions in order to favor their own replication and translation.

Inhibition of Cellular RNA Polymerase

The CTD of host RNA polymerase contains 52 heptapeptide repeats (YSPTSPS) and is phosphorylated primarily at serine amino acids multiple times during the transcription process (Fig. 3.10). These phosphorylation events serve to activate or deactivate the enzyme. Some viruses (herpesviruses, bunyaviruses) counteract this phosphorylation at serine amino acids

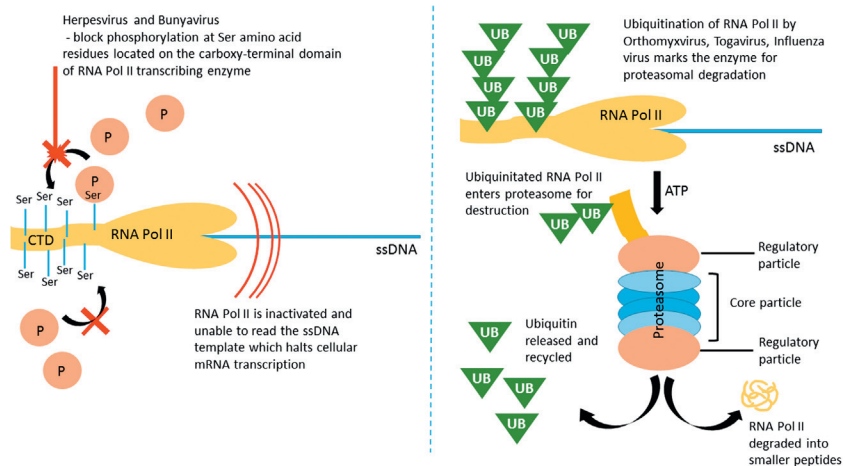

FIGURE 3.10 Examples of mechanisms used by viruses to block the activity of RNA polymerase (RNA Pol) from transcribing cellular mRNA. Phosphorylation of serine residues located on the CTD of the enzymes is blocked by some viruses. Other viruses arrest RNA Pol activity by signaling ubiquitination of the transcribing enzyme, which is subsequently degraded by the proteasome. Virus-encoded protein, ICP-22, of human herpesviruses blocks CTD Ser-2 phosphorylation of host RNA Pol; virus-encoded polymerases, PB1, PB2, PA, cause host RNA Pol ubiquitination and proteasomal degradation; virus-encoded protein, nsp2, is produced by togaviruses and functions in ubiquitination of Rpb1 subunit of host RNA Pol and proteasomal degradation.

to inactivate RNA polymerase, while other viruses (orthomyxviruses, togaviruses) disrupt cellular RNA polymerase function by signaling ubiquitination of the enzyme and its subsequent degradation by proteasomal action.

Disruption of Cellular mRNA Export Pathways

Viruses can engage in targeted disruption of cellular mRNA export pathways to promote preferential viral gene expression (Fig. 3.11). All DNA viruses replicate within the nucleus except poxviruses, asfarviruses, and phycodnaviruses. Few RNA viruses, including bornaviruses, orthomyxoviruses, and retroviruses, replicate in the nucleus. Trafficking between the nucleus and cytoplasm is usually unidirectional for large macromolecules like the mRNA transcript, and occurs through the nuclear pore complex (NPC). Viruses that replicate in the nucleus must out-compete cellular mRNAs to export viral mRNAs out of the nucleus for translation into virus gene products in the cytoplasm. Several viruses can inhibit nuclear export of cellular mRNAs by

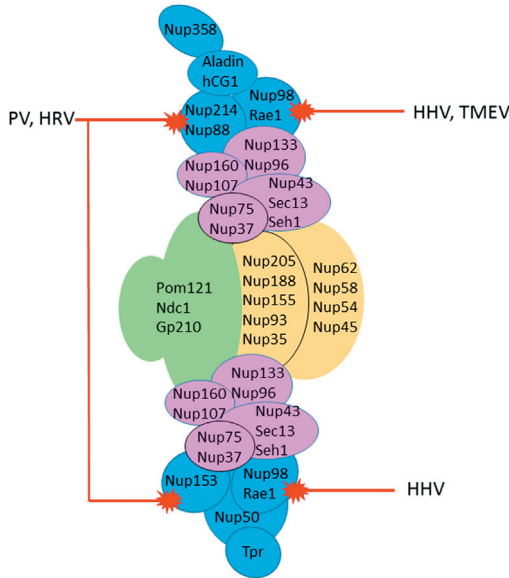

FIGURE 3.11 Inhibition of cellular mRNA export out of the nucleus by targeted disruption of the structure of the NPC. One half of the NPC is shown in the diagram. Vesiculoviruses are negative-stranded (–) RNA viruses that prevent proper cellular mRNA export by interfering with the action of the VSV matrix (M) protein. This effect decreases competition of viral mRNAs with cellular mRNAs for use of the translational machinery. Many DNA viruses (e.g., adenoviruses) also selectively inhibit host mRNA export, while ensuring that viral mRNAs are efficiently exported after transcription (Yarborough et al., 2014). Viruses: PV, Poliovirus; HRV, Human rhinovirus; HHV, Human herpesvirus; TMEV, Theiler’s murine encephalomyelitis virus.

disrupting nuclear export receptors (exportin1 and TIP-associated protein) and nucleoporins that comprise the NPC to compromise their function in nucleocytoplasmic trafficking of cellular mRNA.

Decay of Host mRNAs by Viruses

Viruses have developed different strategies to effectively degrade host mRNAs and to allow preferential translation of their own mRNA (Fig. 3.12). Most viruses produce an endonuclease that cleaves host mRNAs, which are then degraded by host exonucleases (e.g., Xrn1 in mammals). The mRNA fragments are then degraded by mRNA decay pathways (nonsense-mediated decay), and exosomal degradation. *Human gammaherpesvirus 8*, *Human alphaherpesvirus 1*, and *Influenza A virus* all induce destruction of cellular mRNAs. Betacoronaviruses, influenza viruses, vaccinia viruses, and herpesviruses can produce viral endonucleolytic products to an extent that saturates cellular RNA decay-related quality control mechanisms and limit their function. Invariably this mechanism helps viral RNAs escape detection by the cellular RNA decay machinery.

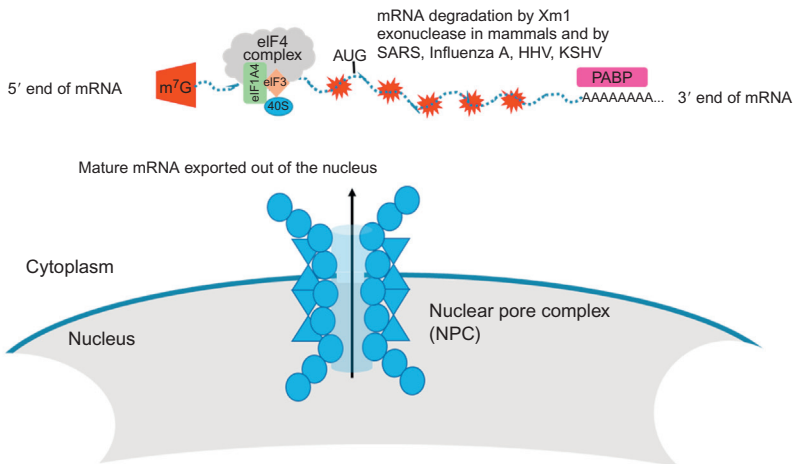

FIGURE 3.12 Degradation of cellular mRNA by viral-encoded endonuclease enzymes allows for preferential translation of viral mRNA. M⁷G—5' cap, eIF—eukaryotic initiation factor, AUG—start codon, PABP—poly(A) binding protein. Viruses: SARS, SARS-coronavirus; Influenza A, *Influenza A virus*; HHV, Human herpesvirus; KSHV, *Human gammaherpesvirus 8* (herpesvirus associated with Kaposi's sarcoma in humans).

Circumvention of Cellular RNA Decay Machinery

Eukaryotic cells utilize a surveillance mechanism to constantly monitor transcripts for aberrant RNA molecules including misfolded, “*mis*”-translated (e.g., mRNAs with a premature termination codon), and mispackaged mRNAs and these transcripts are quickly degraded in the cytoplasm. Transcripts of cytoplasmic viruses must circumvent the cellular mRNA decay machinery to enable virion production. Several cytoplasmic viruses repress key aspects of the cellular RNA decay machinery to escape RNA degradation. Picornaviruses are able to suppress cellular RNA decay factors, and polioviruses and human rhinoviruses produce viral proteases that degrade Xrn1, Dcp1, Dcp2, Pan3 (a deadenylase), and AUF1 decay factors. HCV RNAs have similarly been shown to bind LSm1-7 and knockdown RNA decay factors.

Shutoff of Cellular mRNA Translation

Initiation of translation of cellular mRNA occurs through the recruitment and assembly of a multisubunit translation initiation complex at the 5' end of the mRNA strand (Fig. 3.13). Viruses capable of inducing the shutdown of

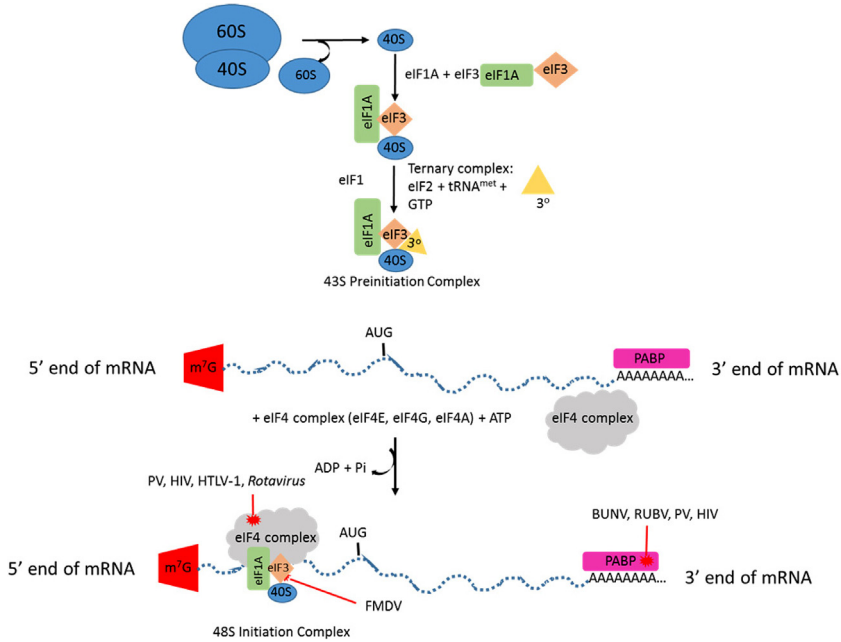

FIGURE 3.13 Shutoff of host translation machinery by viral interference with specific eukaryotic translation initiation factors and poly(A) binding protein (PABP). Viruses: PV, Poliovirus; HIV, *Human immunodeficiency virus I*; HTLV-1, *Human T-lymphotropic virus-1*; FMDV, *Foot-and-mouth disease virus*; BUNV, *Bunyamvera orthobunyavirus*; RUBV, *Rubella virus*.

cellular mRNA translation are able to continue to translate at least part of their mRNAs using noncanonical translation mechanisms, for example, cap-independent translation, ribosome shunting, and leaking scanning (e.g., adenoviruses, picornaviruses, reoviruses, and rhabdoviruses).

Recruitment of Cellular Hsp70 Chaperones for Viral Protein Folding

Most viruses interact with cellular chaperones in order to ensure correct folding of viral proteins. Viral proteins often consist of multiple domains or are produced as polyprotein precursors, which must be processed before they can be functional. The coat protein or capsid is a meta-stable structure that must be specifically assembled in a preordered arrangement without reaching minimum free energy; yet must be disassembled upon entry of the host cell. Some cellular chaperones, for example, Hsp70, are used to accelerate the maturation of viral proteins and are involved in regulating the viral biological cycle. The high rate of mutation in RNA viruses may mean an increased dependency on chaperones for the gene products of these viruses. Hsp70 can refold denatured proteins, which negates some of the destabilizing alterations in structural proteins as a result of mutated genes. This ensures that a high proportion of viral proteins is accurately configured to function in virus multiplication.

Compromising Cellular Lipid Metabolism

Viruses can manipulate the cellular metabolism to provide an increased pool of molecules, for example, nucleotides and amino acids, which are required for viral gene expression and virion assembly. Some viruses need to create a lipid-rich intracellular environment favorable for their replication, morphogenesis, and egress. Replication of HCV occurs on specific lipid raft domains, whereas assembly occurs in lipid droplets. As such, in order for HCV to create replication compartments and increase sites of assembly, the RNA virus requires both the synthesis of fatty acids, for example, cholesterol, sphingolipids, phosphatidylcholine, and phosphatidylethanolamine, and formation of lipid droplets. Lipids are especially required for assembly of virions of enveloped viruses as these molecules are a major component of membranes. Cellular lipid metabolism is affected at three levels: enhanced lipogenesis, impaired degradation, and disruption of export, which is subsequently manifested in the host as HCV-associated pathogenesis. HCV infection is also associated with reduced serum cholesterol and β -lipoprotein levels.

CELL CYCLE DISRUPTION FOR PREFERENTIAL VIRAL REPLICATION

Transition between the phases of the cell cycle is driven by activities of cyclin/cyclin-dependent kinase (Cdk) complexes. Cyclins are a diverse family of proteins whose structure includes a conserved region known as the “cyclin box,” which is necessary for Cdk binding and activation. The cyclins are classified according to the cell cycle phase they regulate: Cyclin D proteins are G1 phase cyclins; Cyclin E and Cyclin A proteins promote cell cycle progression through G1/S phases; Cyclin B proteins are associated with the M-phase (Fig. 3.14).

Viral interference of the host cell cycle can result in the dysregulation of cell cycle checkpoint control mechanisms to promote viral replication and to facilitate efficient virion assembly. Both DNA and RNA viruses specifically encode proteins responsible for targeting and arresting essential cell cycle regulators to create intracellular conditions that are favorable for viral replication and propagation. Retroviruses and other RNA viruses also interfere with the host cell cycle. Viral-mediation of the cell cycle can increase the efficiency of viral gene expression and virion assembly. Cell cycle arrest may delay apoptosis of infected cells. In addition, a specific G2/M-phase cell cycle arrest as induced by *Human immunodeficiency virus 1* prevents new cell production, which aids the virus in immune evasion.

Viruses can initiate the cell cycle and activate TFIIF transcription factors by stimulating cyclin D activity or dissociation of the retinoblastoma (Rb)/TFIIF complex in a cyclin-D-independent manner. Many viruses encode a cyclin-D homolog protein (v-cyclin) that associates with Cdk6 to phosphorylate Rb, which regulates G1 phase. The EBV-EBNA2 and EBV-LP,

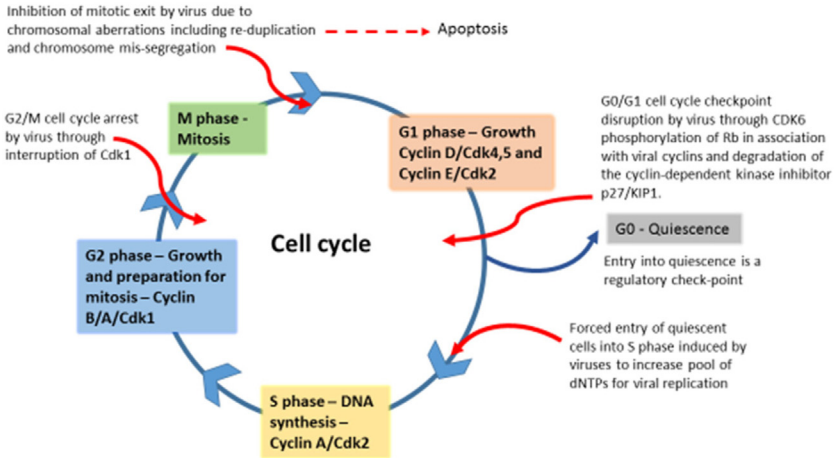

FIGURE 3.14 Cell cycle dysregulation by viruses.

HTLV-1-Tax, and HBV-HBx proteins upregulate cyclin D, which leads to Rb hyperphosphorylation and TFIIF-mediated transcriptional activation. Distinct viral families are able to target the Rb/TFIIF association and promote the premature or unscheduled transition of the infected host cell into the S phase. Other viruses utilize mechanisms that result in G2/M arrest through either inactivation of Cdk1 at the G2/M checkpoint and/or at the interference with mitotic progression. Viruses can also dysregulate mitosis through the activity of viral oncoproteins such as HTLV-1-Tax, Ad-E1A, and HPV-E6/E7, which serve to induce chromosomal aberrations and chromosome mis-segregation that ultimately can result in apoptosis of the cell. Various DNA viruses primarily infect quiescent or differentiated cells, which contain low levels of deoxynucleotides (dNTPs) as these cells do not undergo active cell division. As such, a restricted pool of dNTPs will not provide an ideal environment for viral replication. It has been proposed that such viruses can induce quiescent cells to enter the cell cycle, specifically the S phase, in order to create an environment that generates factors, such as nucleotides, that are required for viral replication. Large DNA viruses, for example, herpesviruses, can cause cell cycle arrest as a mean of competing for cellular DNA replication resources.

The viral-mediated modifications of host cell cycles, which may be detrimental to cellular physiology, significantly contributes to associated pathologies, such as cancer progression and cell transformation. Viral infections may account for approximately 20% of all human cancers worldwide.

A summary of most of the strategies developed by viruses to ensure viral replication and gene expression is provided in [Fig. 3.15](#).

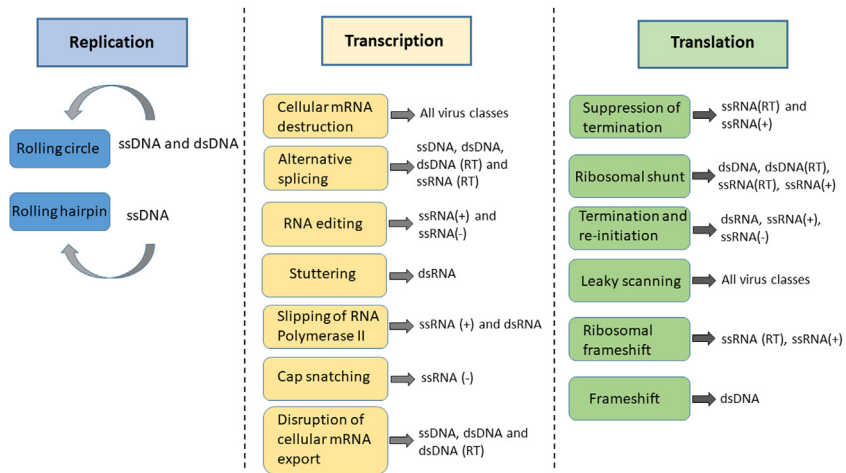

FIGURE 3.15 Summary of strategies developed by viruses to ensure viral replication and gene expression.

VIRUS GENOME REPLICATION COMPLEXES

Finally, viruses have developed a number of targeted strategies to manipulate cellular activities, which enable specific recruitment of macromolecules required for viral replication and gene expression at specific locations in the host cell. Typically, these macromolecules are recruited and concentrated into specific cytoplasmic or nuclear compartments. Formation of such specialized cellular microenvironments, also termed viroplasms, virus factories, virus replication centers, complexes, or compartments, requires the coordinated control of cellular biosynthesis in addition to (1) alterations in the dynamics and distribution of the cytoskeleton and associated motor proteins, (2) relocalization of cellular organelles, and (3) reorganization and redeployment of cellular membranes associated with membrane-bound organelles, for example, the endoplasmic reticulum, mitochondria, chloroplasts, Golgi apparatus, endosomes, and lysosomes in eukaryotes. Formation of viral factories often requires sequestration of mitochondria (and/or chloroplasts) and chaperones to perinuclear sites. In addition, DNA viruses that replicate in the nucleus induce nuclear reorganization and redistribution of chromatin and nuclear domain components such as the nucleolus, interchromatin granules, and Cajal bodies. These compartments provide a scaffold for efficient viral gene expression, while simultaneously concealing viral genomes (refer to Chapter 10: Host–Virus Interactions: Battles Between Viruses and Their Hosts) and their products from immunological detection.

FURTHER READING

- Cavallari, I., Rende, F., D'Agostino, D.M., Ciminale, V., 2011. Converging strategies in expression of human complex retroviruses. *Viruses* 3, 1395–1414. Available from: <https://doi.org/10.3390/v3081395>.
- Dubois, J., Terrier, O., Rosa-Calatrava, M., 2014. Influenza viruses and RNA splicing: doing more with less. *mBio* 5. Available from: <https://doi.org/10.1128/mBio.00070-143e00070-14>.
- Gaglia, M.M., Covarrubias, S., Wong, W., Glaunsinger, B.A., 2012. A common strategy for host RNA degradation by divergent viruses. *J. Virol.* 86, 9527–9530. Available from: <https://doi.org/10.1128/JVI.01230-12>.
- Hoeben, R.C., Uil, T.G., 2013. Adenovirus DNA replication. *Cold Spring Harb. Perspect. Biol.* 5. Available from: <https://doi.org/10.1101/cshperspect.a013003a013003>.
- Moon, S.L., Wilusz, J., 2013. Cytoplasmic viruses: rage against the (cellular RNA decay) machine. *PLoS One Pathogens* 9. Available from: <https://doi.org/10.1371/journal.ppat.1003762e1003762>.
- Nascimento, R., Costa, H., Parkhouse, R.M., 2012. Virus manipulation of cell cycle. *Protoplasma* 249, 519–528. Available from: <https://doi.org/10.1007/s00709-011-0327-9>.
- Swanton, C., Jones, N., 2001. Strategies in subversion: de-regulation of the mammalian cell cycle by viral gene products. *Int. J. Exp. Pathol.* 82, 3–13. Available from: <https://doi.org/10.1046/j.1365-2613.2001.00165.x>.
- Vreede, F.T., Fodor, E., 2010. The role of the influenza virus RNA polymerase in host shut-off. *Virulence* 1, 436–439. Available from: <https://doi.org/10.4161/viru.1.5.12967>.
- Yarbrough, M.L., Mata, M.A., Sakthivel, R., Fontoura, B.M.A., 2014. Viral subversion of nucleocytoplasmic trafficking. *Traffic* 15, 127–140. Available from: <https://doi.org/10.1111/tra.12137>.