

What determines online rumour sharing on COVID-19? A stimulus–response framework

Journal of Information Science
1–17
© The Author(s) 2022
Article reuse guidelines:
sagepub.com/journals-permissions
DOI: 10.1177/01655515221126989
journals.sagepub.com/home/jis

Feng Guo

College of Management and Economics, Qingdao Institute for Ocean Engineering, Tianjin University, China

Apan Zhou

College of Management and Economics, Tianjin University, China

Peng Luo

School of Business, Sichuan University, China

Abstract

Based on the stimulus–response framework, this study examines the external environmental stimuli influencing online rumour sharing about COVID-19 and considers the contingent effect of fear. A large-scale online survey was used to test the proposed research model and hypotheses. The final data set comprised 2807 valid responses. The results indicate that perceptions of community safety and infection risk negatively affect online rumour sharing, while social influence positively affects online rumour sharing. Fear weakens the negative effects of community safety on online rumour sharing but strengthens the positive effect of social influence on online rumour sharing. This study provides a comprehensive analysis by applying the stimulus–response framework to explore the underlying drivers of online rumour sharing with regard to COVID-19 and the moderating effects of fear in the Chinese context.

Keywords

Chinese context; COVID-19; fear; online rumour sharing; stimulus–response

1. Introduction

The COVID-19 pandemic has had a significant impact on people globally, not only threatening their health and wellbeing but also shaping their behaviours on the Internet [1,2]. People have faced many uncertainties regarding the pandemic and seek information about the virus to resolve them [3,4]. In this situation, they often make proactive and rational decisions by obtaining information from the Internet [4,5]. However, since the outbreak, there has been an abundance of misinformation and widespread rumours spread via social media [5,6]. For instance, on 31 January 2020, a rumour that the traditional Chinese medicine *Shuanghuanglian* can inhibit COVID-19 went viral on Chinese social media, resulting in the product being sold out and a high level of market confusion [7]. In another example, there was a widespread rumour that the port of Seattle was closing down following the first confirmed case of COVID-19 in Alaska on 12 March 2020 [6]. Given that rumours about COVID-19 flourish via social media, it is critical to explore the factors determining online rumour sharing.

A rumour is a message that is currently unsubstantiated by a message receiver [1]. Previous studies have drawn attention to rumour sharing on social media. For example, one stream of research focuses on the recognition [8] and classification [9] of rumour standpoints and the detection of rumours [10] on social networks. More recently, Islam et al. [5] explored the effects of motivational factors and personal attributes on rumour sharing via social media during the

Corresponding author:

Peng Luo, School of Business, Sichuan University, No. 24 South Section 1, Yihuan Road, Chengdu 610065, China.
Email: luopeng@scu.edu.cn

COVID-19 pandemic. Using the SIR (susceptible, infected and recovered) model, Wang et al. [7] simulated the spread of online rumours to understand how and why rumours were shared online. Naeem and Ozuem [6] applied qualitative methods to explore how rumours were shared via social media, and how rumours affected panic buying during the COVID-19 pandemic.

In fact, most countries have implemented measures to slow the transmission of COVID-19 [11,12]. Variations in prevention and control measures have caused the social effects and the perceived infection risk to diverge across regions, communities and individuals. According to previous studies [13,14], these external environmental stimuli (i.e. community safety, social influence and infection risk) were important factors that influenced online rumour-sharing behaviour during the pandemic. However, empirical studies about the effects of external environmental factors on rumour sharing via social media are limited and inadequate, and a better understanding of the issue is important for individuals and society [13–15]. Moreover, fear of COVID-19 affects individuals' cognition, attitudes and behaviours in response to the pandemic, which may play a contingent role in the relationship between environmental stimulus and individuals' rumour-sharing behaviours [16–18]. Although previous studies have focused on the important role of fear, they have not considered fear as a contingency factor in rumour sharing. COVID-19 fears shape individuals' cognition, attitude and behaviours, which play a contingent role in the relationship between environmental cues and rumour-sharing behaviours [18–20]. To fill the above gaps in the research, this study examines how external environmental stimuli influence the sharing of COVID-19 rumours online and considers the contingent effects of fear. The research questions were informed by the following:

RQ1. How do external environmental stimulus (community safety, social influence and infection risk) influence online rumour sharing on COVID-19?

RQ2. What role does fear play in the above relationship?

According to the stimulus–response framework, individuals are stimulated by external environmental stimuli (e.g. community safety, social influence and infection risk), which subsequently trigger a response (e.g. rumour-sharing behaviours) [13,21,22]. A sense of community safety reduces feelings of uncertainty and anxiety as well as belief in rumours, which is unlikely to induce rumour sharing via social media [23]. Social influence involves common concerns and the discussions and sharing of information about the pandemic among friends and relatives [24]. It may encourage individuals to share online rumours without validation [24,25]. Perceived infection risk refers to individual expectations of infection rates and the potential losses caused by infection [26,27], which may augment anxieties and online rumour sharing [28,29]. Meanwhile, fear is a basic emotion that motivates people to avoid a particular threat, such as infection with COVID-19 [30,31], which may be a contingent factor affecting an individual's cognition, attitudes and behaviours in response to the pandemic [16,32]. In the context of fear, a sense of community safety may not completely eliminate uncertainty and anxiety, the positive effect of social influence on rumour sharing may be amplified, and perceived infection risk may be even more probably to lead to rumour sharing. Thus, the potential negative effect of community safety on online rumour sharing may be weakened by fear and the potential positive effects of social influence and perceived infection risk on online rumour sharing may be intensified by fear.

Drawing on the literature on stimulus–response, fear and online rumour sharing, we developed a research model based on six hypotheses. To test our hypotheses, we collected data from 2807 respondents in China using an online survey. Our empirical results indicate that perceptions of community safety and infection risk decrease online rumour sharing, whereas social influence increases online rumour sharing. Furthermore, as a moderating force, fear weakens the negative effects of community safety on online rumour sharing but strengthens the positive effects of social influence.

From these findings, this study makes several contributions to the literature. First, this study contributes to the stimulus–response literature by applying the stimulus–response framework to explore the mechanisms of online rumour sharing with respect to COVID-19. Studies that have applied the stimulus–response framework to analyse rumormongering behaviours during the COVID-19 pandemic are limited and insufficient [33–35]. By applying the stimulus–response framework, this study enhances the understanding of online rumour-sharing behaviours by identifying important environmental factors. Second, this study reveals the moderating effects of fear on online rumour-sharing behaviours. Our focus on the role of fear in rumormongering is also in line with the appeal to consider the context of psychological issues or negative affects during the pandemic [34,36]. Finally, this study constructs a framework to better understand online rumour-sharing behaviours with respect to COVID-19 in the Chinese context. Given that the early propagation patterns in China are unclear, analysing the rumour-sharing behaviours of Chinese social media users contributes to understanding the mechanisms of rumormongering in the early stages of crises and on Chinese social media platforms other than Twitter (e.g. WeChat) [37,38].

This article is structured as follows. After the introduction, the theory and hypotheses are described in section 2. The research method is presented in section 3, and the results are presented in section 4. Section 5 discusses the findings, contributions, implications, limitations and topics for future research.

2. Theoretical background and hypothesis development

2.1. Stimulus–response framework

Developed in the early 20th century, the stimulus–response theory combines psychological and sociological theories [33,39]. The two important constructs in the framework are stimulus and response. The stimulus is the social environment or environmental cue that causes the individual’s psychological or behavioural response [13]. In other words, it is the outside force that affects an individual’s psychological state [40,41]. Response refers to the individual’s final behavioural outcomes, which may be positive or negative [39,42]. Responses may include the intentions, decisions or behavioural changes caused by a stimulus [13]. This framework describes how external stimuli trigger or explain individual behavioural responses [21,22].

The stimulus–response framework is well accepted and has been extensively applied to understand human behaviours in the social media and online [39,43]. Recently, Song et al. [35] applied the stimulus–response framework to investigate consumers’ information-avoidance behaviours in the context of a public health emergency, specifically the COVID-19 pandemic in China. Similarly, Barua et al. [33] adopted the framework to analyse the effect of COVID-19 misinformation on individual responses. Ali et al. [34] explored three different types of misinformation about COVID-19 that serve as stimuli generating favourable or unfavourable responses.

The COVID-19 pandemic is a catastrophic emergency that has created enormous social impacts worldwide [1,2]. Its rapid development has led to people globally being aware that they are at risk of infection [44]. To slow the transmission of COVID-19, most countries have implemented control measures such as quarantining, social distancing and isolation of infected people [11,12]. The strength of disease prevention and control measures, the social impacts of the pandemic, and perceived infection risk differ across regions, communities and individuals and may cause variations in individuals’ psychological states. Moreover, information needs have increased since the pandemic. Rumouring is seen as a collective and improvised information seeking and exchanging behaviour among citizens during infectious disease outbreaks [45–47]. Therefore, in this study, we consider three key features of COVID-19 (i.e. community safety, social influence and infection risk) as important environmental stimuli leading to online rumouring behaviours [13].

As a highly infectious virus that spreads rapidly among humans, COVID-19 has severely affected the health and well-being of people worldwide, leading to widespread and intense fear [18]. Fear of COVID-19 can affect individuals’ cognition, attitudes and behaviours in response to the virus and may play a contingent role in the relationship between environmental cues and individuals’ rumour-sharing behaviours [16–18]. Previous studies suggest that fear triggers cognitive appraisal processes concerning the severity of a threat, thus may be reasonably considered a contingent factor during crises [48,49]. However, few studies have accounted for the contingent effect of fear on rumormongering in the context of a social crisis.

Although some studies have focused on rumour-sharing behaviours via online social platforms, few have applied the stimulus–response model to analyse the impact of environmental cues related to the COVID-19 pandemic on individuals’ rumour-sharing behaviours [15,50]. The stimulus–response model is an important and widely used psychological model because it reveals the effects of environmental cues on individual behaviours [39,51]. Applying the stimulus–response model in online rumour sharing is beneficial to uncover the mechanism that individuals are stimulated by environmental cues and their response to them by sharing rumours on social media. Therefore, we adopted the stimulus–response framework to explore online rumour-sharing behaviours during the COVID-19 pandemic. In our framework, individuals may be stimulated by a sense of community safety and the effectiveness of prevention and control measures (community safety), encouragement from friends and relatives to pay attention to the pandemic (social influence) and perceived risk of infection (infection risk). In turn, these stimuli affect individuals’ online rumour-sharing behaviours as response. Furthermore, we consider fear as a contingency factor to better explain the relationships between these stimuli and online rumour sharing.

2.2. Community safety and online rumour sharing

Community safety refers to the effectiveness of community prevention programmes, including measures to facilitate the early detection of patients with COVID-19 and protect residents from secondary transmission and infection [52]. A rumour is a message that is currently unsubstantiated by the message receiver [1]. Rumours are defined as collective and

improvised information seeking and exchanging behaviours among citizens to cope with social tension and solve crises [45]. A sense of community safety may mitigate individuals' rumour-sharing behaviours by decreasing feelings of uncertainty and anxiety as well as beliefs in rumours, which are important predictors of rumour-sharing activities [23].

First, feelings of uncertainty will be reduced if community prevention programmes are perceived to be effective. A sense of community safety may be elicited by effective prevention programmes that strive to improve the public's awareness of prevention and intervention strategies [53], reducing feelings of uncertainty [54]. Thus, eliminating uncertainty during the pandemic is probably to reduce rumour-sharing behaviours [45,55]. Second, while the risk of infection, illness, death and other adverse effects of COVID-19 has created anxiety for individuals worldwide, effective community prevention programmes, including psychological support services, can alleviate individual stress and anxiety [29,53], thereby mitigating rumour-sharing behaviours. Finally, individuals are more probably to engage in rumour sharing when they believe rumours to be true, especially during periods of shared anxiety such as during an epidemic [56]. Community prevention programmes provide information about the virus and disease prevention, increasing individuals' understanding of COVID-19 [54]. Thus, these individuals are less probably to believe in and share rumours. Based on these arguments, we propose the following hypothesis:

H1. Community safety is negatively related to online rumour sharing.

2.3. Social influence and online rumour sharing

Social influence refers to encouragement from peers, friends and relatives to embark on a certain action [24,25]. In the context of the COVID-19 pandemic, social influence involves common concerns, extensive discussions and sharing of information about the pandemic among friends and relatives [24]. Social influence is a significant determinant of one's intention to engage in certain actions because peers can reason with and persuade others to see things in a certain way [57,58]. Undoubtedly, an individual's sphere of social influence can increase their feelings of uncertainty and shape their beliefs, thus increasing their rumour-sharing behaviours.

Given the expanding social influence related to the pandemic, individuals are more probably to receive unconfirmed and unverified information from a higher number of informal social network channels and sources [45]. Numerous unverified messages will increase uncertainty about the situation. To release the social tension created by uncertainties related to COVID-19, people often turn to social media to share rumours [59]. Meanwhile, common concerns about the pandemic among friends and relatives may increase the sense of importance placed on the issue. Individuals often follow the behaviours of their peers and feel social pressure to conform as they become more involved in extensive discussions about COVID-19 [60]. They are also more willing to share rumours through their social networks to express their emotions and increase their social bonding by showing emotional similarity [61]. In addition, social support or social ties are critical elements in rumour believing and sharing [62]. Since the crisis, individuals have turned to close social networks such as friends and relatives to acquire relevant information, and engaging in interpersonal communication within these trusted groups is an important source of information sharing [62,63]. As the social influence related to COVID-19 expands, individuals become increasingly exposed to rumours from their close social networks. Such close and affective social networks are inclined to impose social pressure over fact-checking, reducing the probability that recipients will verify ambiguous messages for themselves [64]. In other words, social influence leads to the exchange of information in close social networks, enhancing individuals' beliefs in rumours and rumour-sharing behaviours. Therefore, we propose the following hypothesis:

H2. Social influence is positively related to online rumour sharing.

2.4. Infection risk and online rumour sharing

Perceived infection risk refers to an individual's perception and evaluation of the possibility of contracting COVID-19 and the negative outcomes of infection [65]. Understanding individuals' perceived risk of viral infection helps to understand their attitudes and behaviours [65]. For example, prior studies have found that one's perceived risk of infection influences one's information-seeking behaviours [66] and safety nets (e.g. insurance) [67]. In the rumour context, perceived infection risk during the COVID-19 pandemic is expected to have a positive effect on online rumour sharing.

First, when individuals perceive a higher risk of infection, the relevance and importance of COVID-19-related information or rumours will increase. In other words, perceived infection risk increases the individual's sense of personal involvement, leading to an inclination to share rumours [61]. In addition, perceived risk of infection promotes information seeking [46], which is considered a method of mitigating risk [66]. Indeed, information seeking is a key driver of

social media users sharing news or rumours to seek opinions from friends about that information [1], thus enhancing online rumour sharing. Furthermore, higher perceived infection risk increases feelings of anxiety and physical insecurity, leading to a higher propensity to share rumours [28,29]. Based on the above arguments, we propose the following hypothesis:

H3. Perceived infection risk is positively related to online rumour sharing.

2.5. Moderating effects of fear

Fear is a basic emotion that motivates people to avoid a particular threat, such as COVID-19 infection [30]. It is usually a negative emotion, elicited by feeling threatened and out of control, triggering measures to minimise the threat [49]. As a widespread and strong emotion during an infectious disease outbreak, fear may be a contingent factor affecting individuals' cognition, attitudes and behaviours in response to the pandemic [16,32]. Therefore, we expect that fear will have a moderating effect on the relationship between environmental cues (i.e. community safety, social influence and infection risk) and online rumour-sharing behaviours in the COVID-19 context.

Community safety may reduce individuals' rumour-sharing behaviours by regulating the degree of uncertainty and anxiety as well as belief in rumours, which are important predictors of rumour-sharing activity [23]. However, fear may weaken the negative effect of community safety on rumour sharing. First, fear initiates a cognitive assessment of the severity of COVID-19 and can lead individuals to feel more uncertain and less in control [16,49]. When an individual is fearful, even a safe community environment and an effective disease prevention programme may result in a high level of uncertainty and the tendency to engage in rumour sharing. Second, fear can reshape cognitive appraisals of the efficacy of recommended control measures, potentially leading to a loss of confidence [48]. In this situation, community safety may not ease the anxiety of individuals, who continue to search for information and share rumours. Third, fearful individuals tend to take positive and sometimes exaggerated precautionary steps to minimise threats [12,68]. In this context, the implementation of a community prevention programme may not eliminate the threat, thus they will take further measures such as sharing rumours or information to minimise the threat. Thus, we propose the following hypothesis:

H4. Fear weakens the negative relationship between community safety and online rumour sharing.

As noted above, strong social influence promotes rumour sharing. Previous studies have found that fear triggers people to seek social support to protect themselves from threats [18]. Thus, the positive effect of social influence on rumour sharing may be amplified by fear. First, fear enhances loneliness and encourages individuals to seek social support and participate in social interactions to obtain informal information [18,49]. Individuals who are fearful of COVID-19 may be more influenced by their social networks, thus be exposed to a higher level of unverified information [45], leading to ambiguity, uncertainty and anxiety, in turn promoting rumour sharing [28]. Therefore, the positive effect of social influence on rumour sharing will be intensified. Second, fearful individuals are less probably to critically assess rumours and more probably to make irrational decisions based on incomplete or incorrect information about COVID-19 [69]. In this context, social influence means that individuals are exposed to a number of rumours from relatives and friends and are unlikely to verify rumours, thus are probably to believe in and share rumours. Based on these discussions, we propose the following hypothesis:

H5. Fear strengthens the positive relationship between social influence and online rumour sharing.

As mentioned above, perceived infection risk leads to an increase in online rumour sharing, mainly by enhancing its importance and feelings of anxiety. This is probably to be even more significant in fearful individuals. First, fear amplifies individuals' perceptions of risk and elicits pessimistic expectations of infection rates and potential losses [70,71]. Thus, the effect of perceived infection risk on rumour-sharing behaviours will be stronger in the context of fear. Second, fear promotes people to take risks and threats more seriously and increases their motivation for self-protection [72,73]. For fearful individuals, risk perception means higher self-involvement and the need to avoid risks. In this context, a higher perceived infection risk will increase high self-involvement by conducting rumour-sharing behaviours. Moreover, fear is a cognitive tendency that emphasises uncertainty and loss of control and tends to magnify the anxiety caused by the risk [16]. In this situation, high perceived infection risk may increase rumour-sharing behaviours. Based on the above arguments, we propose the following hypothesis:

H6. Fear strengthens the positive relationship between perceived infection risk and rumour sharing.

In summary, we present our research model in Figure 1.

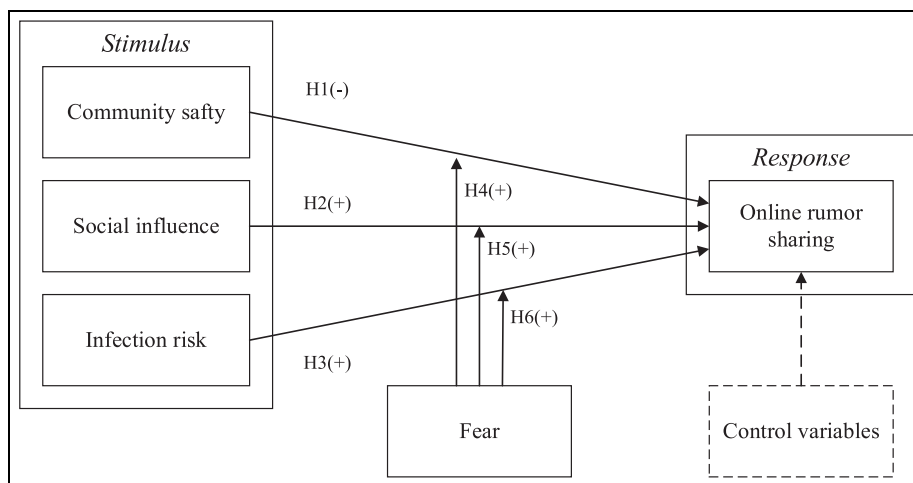

Figure 1. Research model.

3. Research methodology

3.1. Data collection

An online survey was conducted in February 2020, when the COVID-19 outbreak in China was significant, resulting in many different rumours spreading via social media. We adopted a large sample pool from China provided by an online platform (<http://www.sojump.com/>) [74,75]. A snowball sampling technique was adopted, and a link to the questionnaire was spread via WeChat. We provided a small reward of 2–5 CNY to attract more respondents. To avoid common method bias, we adopted the methods used by Cooper et al. [76] and Mullins and Agnihotri [77] in the data collection process. First, the participants were engaged anonymously to participate in the online survey. Second, the questionnaires were randomly arranged, so the questions were presented in a different order for each of the participants. In total, we received 4684 responses, of which 1877 were removed because the time spent on them was less than 100 s and more than 15 continuous answers were the same. Our final sample for data analysis comprised 2807 valid responses. Participant demographics are shown in Table 1. Of the final sample, 49.412% were male, 65.693% were under the age of 30 years, and 60.492% had a bachelor’s degree or higher.

Table 1. Sample demographics.

Characteristics	Levels	Frequency	Percentage (%)
Gender (GE)	Male	1387	49.412
	Female	1420	50.588
Age group (AG)	< 18	136	4.845
	18–25	1061	37.798
	26–30	647	23.050
	31–40	590	21.019
	> 41	373	13.288
Education (ED)	≤ Junior college	1109	39.508
	Undergraduate	1257	44.781
	Postgraduate	441	15.711
Live group (LG)	Live alone	1614	57.499
	Live with relatives	853	30.388
	Live with others	340	12.113

3.2. Measures

Appendix 1 showed the construct items, which were mostly adapted from the existing literature. Rumour sharing was measured using three items adapted from Venkatesh et al. [78]. Infection risk was measured using three items adapted from Colindres et al. [79]. Social influence was measured using three items adapted from Suki and Suki [24]. Community safety was measured using two items adapted from Emerson et al. [80]. Fear was measured using three items adapted from Boss et al. [69].

We adopted a 5-point Likert-type scale ranging from 1 (*strongly disagree*) to 5 (*strongly agree*). We first developed an English version of the questionnaire, which was then translated into Chinese by three independent authors to ensure no difference between the English and Chinese versions of measures. To be more specific, two authors translated the English questionnaire into Chinese independently before comparing their translations and reaching an agreement on the final Chinese version; a third author then translated the Chinese version back to English to examine the consistency of the final Chinese version. Moreover, before distributing the questionnaire, a group of information systems' scholars were invited to review the content validity of the questionnaire and the accuracy of the interpretation of measurement items. Finally, we collected and controlled for other variables related to respondents, including gender (GE), age group (AG), educational background (ED), work (WO) and live group (LG).

4. Data analysis

4.1. Measurement model

Given that our constructs were measured by a survey, we first tested our model for reliability and validity. Table 2 presents the convergent validity results. Cronbach's alpha values were all above 0.70, composite reliability of all constructs was greater than 0.70, and all average variance extracted (AVE) values exceeded 0.50. Factor loading values of all other items were above 0.70. Based on these results and the existing literature [81,82], we concluded that our measures were reliable.

Table 2. Scale properties.

		Factor loading	Cronbach's alpha	CR	AVE
Online rumour sharing (ORS)	ORS1	0.864	0.925	0.925	0.805
	ORS2	0.928			
	ORS3	0.900			
Community safety (CS)	CS1	0.621	0.740	0.776	0.644
	CS2	0.950			
Social influence (SI)	SI1	0.810	0.812	0.815	0.597
	SI2	0.689			
	SI3	0.813			
Infection risk (IR)	IR1	0.943	0.944	0.943	0.893
	IR2	0.947			
Fear (FR)	FR1	0.873	0.915	0.916	0.785
	FR2	0.931			
	FR3	0.853			

CR: composite reliability; AVE: average variance extracted.

Table 3 presents the results of discriminant validity, where we compared the square root of the AVE of a construct with its correlations. We found that the correlation coefficients of each construct with other constructs were much lower than the square root of AVE, showing the discriminant validity of our model [74,83]. Moreover, we checked for multicollinearity using the variance inflation factor test. The values of all main variables were less than 2, some values for control variables were about 6, and the overall mean value was below 3. Following the existing literature [83,84], multicollinearity was not a serious issue in this study.

Furthermore, given the self-reported nature of the data, there was a potential for common method bias. To check for this, we first conducted Harman's single factor test [85] and found that the first unrotated factor explained only 22.122% of the variance. Second, we adopted the unmeasured latent method construct approach [86,87], which showed that the trait factors explained approximately 60.313%, while the method factor explained only 13.191% of total variance. Given the low method factor variance, we concluded that common method bias was not a threat in this study.

Table 3. Correlations and discriminant validity.

	ORS	CS	SI	IR	FR	GE	AG	ED	WO	LG
ORS	0.897									
CS	−0.037	0.802								
SI	0.231	0.053	0.772							
IR	−0.070	0.171	0.238	0.944						
FR	0.247	0.009	0.346	0.258	0.866					
GE	−0.059	−0.023	0.045	0.065	0.057	−				
AG	0.040	0.087	0.026	0.018	−0.036	0.043	−			
ED	−0.064	−0.085	0.143	0.150	0.039	0.044	−0.087	−		
WO	−0.076	0.034	−0.044	0.026	−0.088	0.004	0.409	−0.074	−	
LG	0.030	−0.000	−0.039	−0.043	−0.014	−0.038	−0.103	−0.111	−0.050	−

ORS: online rumour sharing; CS: community safety; SI: social influence; IR: infection risk; FR: fear; GE: gender; AG: age group; ED: education background; WO: work condition; LG: live group.

The diagonally arranged data are the square roots of AVEs.

Table 4. Estimation results.

Variables	ORS	ORS	ORS	ORS	ORS
CS		−0.076*** (0.023)	−0.422*** (0.075)	−0.419*** (0.075)	−0.420*** (0.076)
SI		0.304*** (0.027)	0.310*** (0.027)	−0.009 (0.073)	−0.012 (0.076)
IR		−0.108*** (0.018)	−0.103*** (0.018)	−0.099*** (0.018)	−0.093 (0.053)
FR × CS			0.097*** (0.020)	0.096*** (0.020)	0.097*** (0.020)
FR × SI				0.094*** (0.020)	0.095*** (0.020)
FR × IR					−0.001 (0.015)
FR	0.267*** (0.019)	0.220*** (0.020)	−0.186* (0.087)	−0.523*** (0.112)	−0.520*** (0.076)
Constant	1.539*** (0.182)	1.391*** (0.211)	2.789*** (0.358)	3.857*** (0.423)	3.848*** (0.429)
Controls	Controlled	Controlled	Controlled	Controlled	Controlled
Obs.	2807	2807	2807	2807	2807
F	21.000	24.830	24.970	25.070	24.370
R-square	0.185	0.228	0.234	0.240	0.240
Adj-R ²	0.176	0.218	0.225	0.230	0.230
RMSE	1.019	0.992	0.988	0.984	0.984

ORS: online rumour sharing; CS: community safety; SI: social influence; IR: infection risk; FR: fear; GE: gender; AG: age group; ED: education background; WO: work condition; LG: live group; RMSE: root mean square error.

* $p < 0.05$; ** $p < 0.01$; *** $p < 0.001$.

4.2. Structural model

We used Stata to analyse the data. The regression results are presented in Table 4. First, with respect to the direct influence of community safety on online rumour sharing, the coefficient is significant and negative ($b = -0.076$, $p < 0.001$). When individuals felt safe in the community, they were less probably to share rumours. This result supports H1, which posits a negative relationship between community safety and online rumour sharing.

Second, Table 4 shows that social influence strongly and positively affected online rumour sharing ($b = 0.304$, $p < 0.001$). When controlling for other variables, the probability of rumour-sharing behaviours increased by approximately 30.4% for every one unit increase in social influence. Thus, H2 is strongly supported.

Third, Table 4 shows a significant negative relationship between perceived infection risk and online rumour sharing ($b = -0.108$, $p < 0.001$). This suggests that when individuals know more about the risk of virus infection, they are less probably to share rumours. This is contrary to our assumption; thus, H3 is not supported. One possible explanation is the rapid outbreak of COVID-19 may remind people worldwide about the risk of infection. A perceived infection risk can lead to an increased focus on the self and engagement in preventive behaviours [88,89], thereby reducing the tendency to share rumours on social media.

Finally, the coefficients on the moderating effect of fear on the relationship between social influence ($b = 0.097$, $p < 0.001$) and infection risk ($b = 0.094$, $p < 0.001$) and online rumour sharing. These results indicate that when

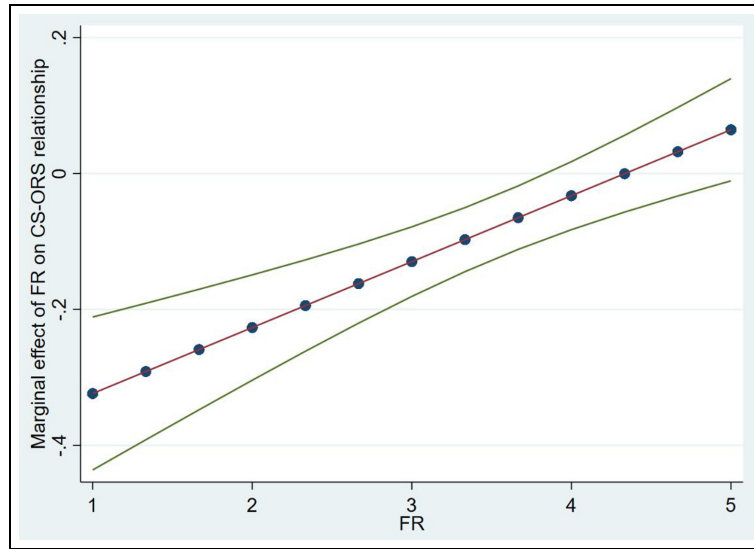

Figure 2. Moderation effect of fear (FR) on the relationship between community safety (CS) and online rumour sharing (ORS).

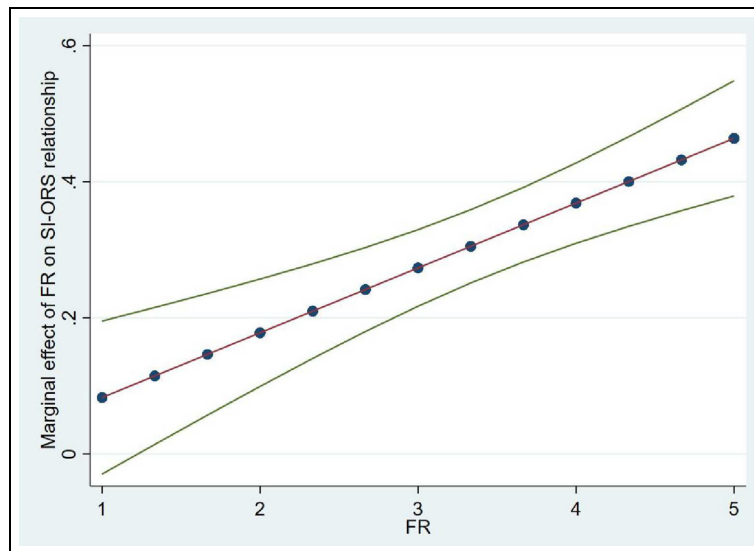

Figure 3. Moderation effect of fear (FR) on the relationship between social influence (SI) and online rumour sharing (ORS).

individuals felt fearful, the negative effect of community safety on online rumour sharing is weakened and the positive effect of social influence on online rumour sharing is strengthened. These results support H4 and H5. Figures 2 and 3 present the marginal effect of community safety and social influence on online rumour sharing at different levels of fear, respectively. Seeing from Figures 2, as the level of fear increases, the negative effects of community safety on rumour sharing become significantly weaker. In other words, when the level of fear increases, the slope of the relationship between community safety and rumour sharing becomes flatter. By contrast, Figure 3 indicates that when the level of fear increases, the positive effect of social influence on rumour sharing becomes significantly stronger. This means the slope of the relationship between social influence and rumour sharing becomes steeper as the level of fear increases.

However, we found that fear did not significantly moderate the effect of infection risk on online rumour sharing ($b = -0.001, p > 0.05$). Thus, H6 is not supported. One possible explanation is that individuals with a high perceived risk of infection are more probably to self-focus and engage in protective behaviours against COVID-19 regardless of whether they are fearful [88,89]. Thus, the effect of perceived infection risk on rumour sharing may not be influenced by

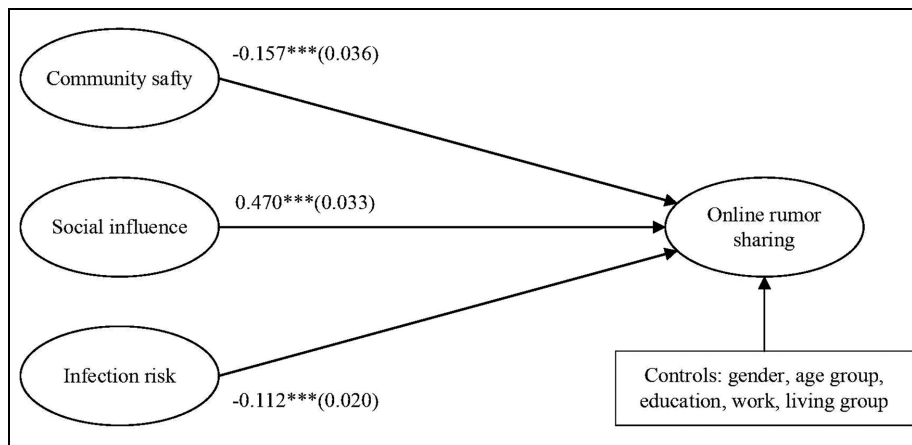

Figure 4. Path coefficient (standard error) in structural equation model.
 * $p < 0.05$; ** $p < 0.01$; *** $p < 0.001$.

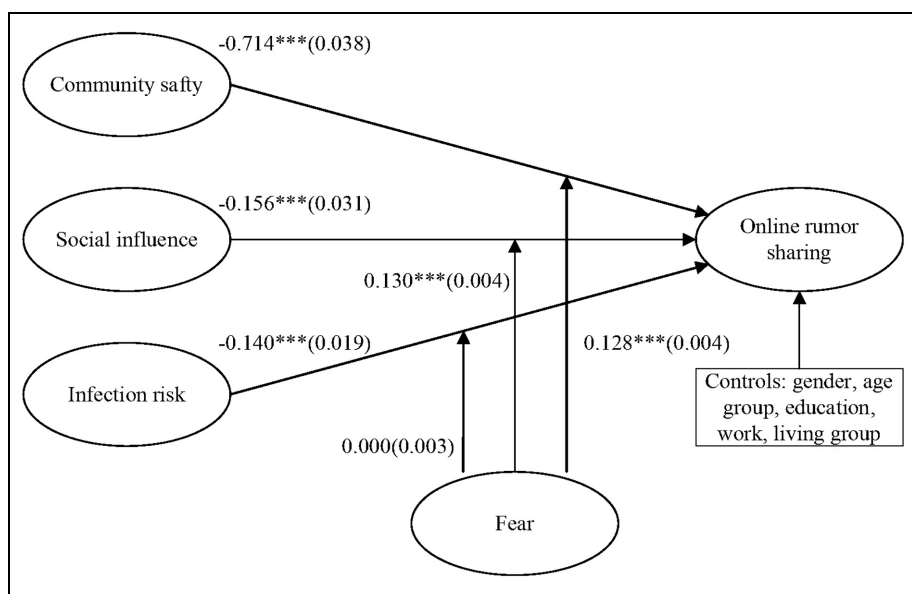

Figure 5. Path coefficient (standard error) in structural equation model with moderators.
 * $p < 0.05$; ** $p < 0.01$; *** $p < 0.001$.

fear. Based on the estimation results, we also found that all the control variables can significantly affect online rumour sharing. For example, compared with the male participants, the female participants have less possibility to share the online rumour ($b = -0.108, p < 0.01$). Similarly, younger participants ($b = -0.269, p < 0.01$) and participants who have received higher education ($b = -0.333, p < 0.05$) are also less probably to share online rumour.

4.3. Robustness check

To check the robustness of our research results, following the suggestion of Garg [90] and Özgür [91], we adopted AMOS to run the structural equation model. The results are presented in Figures 4 and 5. Figure 4 shows that social influence significantly increased the online rumour sharing ($b = 0.470, p < 0.001$), while both community safety ($b = -0.157, p < 0.001$) and perceived infection risk ($b = -0.112, p < 0.001$) significantly decreased the online rumour sharing.

Table 5. Summary of hypothesis conclusion.

	Hypothesis	Results
H1	Community safety is negatively related to online rumour sharing.	Supported
H2	Social influence is positively related to online rumour sharing.	Supported
H3	Perceived infection risk is positively related to online rumour sharing.	Not supported
H4	Fear weakens the negative relationship between community safety and online rumour sharing.	Supported
H5	Fear strengthens the positive relationship between social influence and online rumour sharing.	Supported
H6	Fear strengthens the positive relationship between perceived infection risk and rumour sharing.	Not supported

Figure 5 presents the results for the moderating effect of fear. Fear significantly weakened the negative effect of community safety on online rumour sharing ($b = 0.128, p < 0.001$) and strengthened the positive effect of social influence on online rumour sharing ($b = 0.130, p < 0.001$). However, the moderating effect of fear on the relationship between infection risk and online rumour sharing is not significant. These results are consistent with our main results.

Table 5 summarises the findings of the hypotheses testing. Except for H3 and H6, the hypotheses are supported by empirical results. Accordingly, our key findings are as follows. Perceptions of community safety and infection risk can significantly decrease online rumour sharing, whereas social influence can significantly increase online rumour sharing. Thus, regarding the negative effects of perceptions of community safety, fear can strongly weaken the relationship, whereas regarding the positive effects of social influence, fear can strongly strengthen the relationship.

5. Discussion

5.1. Key findings

First, our findings show a negative relationship between perceptions of community safety and online rumour sharing. In other words, individuals who trusted that the government had implemented effective disease control measures were less uncertain and anxious, and thus less probably to engage in rumormongering. Previous studies have highlighted the importance of government-implemented prevention and control measures, despite these being unable to eliminate deaths and the economic effects of COVID-19 [11]. According to the review by Pian et al. [36], both large-scale lockdowns and distrust of the government could lead to individuals sharing rumours. Their findings implied the necessity of and challenges for governments in taking rational prevention measures. Our results support these insights and indicate that effective prevention programmes conducted by communities could improve citizens' wellbeing by reducing the spread of rumours.

Second, there was a positive relationship between social influence and online rumour-sharing behaviours during the COVID-19 pandemic. Social influence is considered encouragement from friends and relatives to engage in certain activities. A study by Li et al. [13] found that social influence could increase panic behaviours during COVID-19. Similarly, our results indicate that the likelihood an individual will share rumours increases with the expansion of social influence that promotes social network interactions and the exchange of information obtained from informal channels where rumours are prevalent. Moreover, this finding is similar to the echo chamber effect, which indicates that rumormongering is amplified when interest in the rumour is shared by a community [92].

Third, our results show a negative relationship between infection risk and online rumour sharing, which is contrary to our hypothesis. Previous study [13] has indicated that perceived risk or pandemic severity may cause negative outcomes such as panic buying, while others [93,94] have indicated that risk perception contributes positively to shaping an individual's intention to adopt prevention measures. Our results are more inclined to the latter.

Finally, our results show that fear moderates the relationships between environmental stimuli and rumour-sharing behaviours. Specifically, fear weakens the negative relationship between community safety and online rumour sharing and strengthens the positive relationship between social influence and online rumour sharing. Fearful individuals have a higher need for emotional support and are more probably to make irrational decisions based on incomplete or incorrect information [18,69]. Consequently, the environmental factors associated with COVID-19 are more probably to encourage rumour sharing. By revealing the contingent role of fear, our results support the findings of previous studies that show that dread rumours accompanied by fear are shared more frequently than other rumours [19,20]. Thus, the hypothesis that fear strengthens the positive relationship between perceived infection risk and rumour sharing is not supported.

5.2. Theoretical contributions

This study makes several theoretical contributions to the existing literature. First, this study extends the stimulus–response literature by applying a stimulus–response framework to identify the mechanisms of online rumour sharing about COVID-19. First presented in psychology literature, the stimulus–response framework describes how external stimuli trigger and explain individual behavioural responses [21,22]. The stimulus–response framework has been widely applied in information systems’ research to explain individuals’ online behaviours; for example, social media self-control and online health-knowledge sharing [39,43]. In addition, Ali et al. [34] adopted the stimulus–response framework to explore different types of misinformation about COVID-19 that served as stimuli that generated favourable and unfavourable responses. However, the existing literature that applies the stimulus–response framework to analyse online rumormongering behaviours during the COVID-19 pandemic is limited and insufficient [33–35]. By adopting the stimulus–response framework, this study enhances the understanding of online rumour sharing by identifying three important environmental factors (i.e. community safety, social influence and infection risk) as stimuli for the rumour-sharing response. Our results suggest the control measures implemented by the Chinese Government during the COVID-19 pandemic were effective in reducing rumours. Moreover, our results emphasise the existing concerns about social influence which amplifies and rapidly spreads rumours about COVID-19 via social networks. Furthermore, our results show perceived infection risk decreases online rumour sharing. Thus, by revealing the effects of these stimuli, this study promotes a greater understanding of rumour-sharing behaviours during public crises.

Second, this study enriches the literature on fear by revealing the contingent effect of fear on online rumour sharing. Previous studies have indicated that fear stimulates cognitive appraisal processes about a threat’s severity and may have an impact during crises [48]. Attention has also been given to the role of fear during the COVID-19 pandemic in shaping human behaviours such as protective travel behaviours [18], customer behaviours [32] and information seeking [12]. Moreover, Pian et al. [36] described a vicious circle of fear (as a psychological issue) in rumour-spreading behaviour. However, the moderating role of fear has long been neglected in rumour-sharing literature despite the findings that dread rumours accompanied by fear are transmitted more often than other rumours [19,20]. In fact, fearful individuals tend to make irrational decisions based on incomplete or incorrect information [18,69]. In this context, environmental factors (i.e. community safety and social influence) are more probably to encourage rumour sharing. Our results indicate that fear amplifies rumour-sharing behaviours through a moderating mechanism. Thus, this study enriches the literature on fear and rumour sharing by clarifying the contingent effects of fear on the relationship between environmental cues related to COVID-19 and rumour sharing.

Finally, this study enriches the literature on online rumour sharing by introducing a framework of online rumour sharing with respect to COVID-19 in the Chinese context. On one hand, pandemic control measures are relatively strict in China, which provides a unique research setting in which to consider the effects of specific environmental factors [53]. On the other hand, China has experienced a short but rapid period of Internet development as an emerging economy. Therefore, the behaviour of Chinese Internet users may differ from that of users in developed countries. By focusing on users of WeChat, which is characterised by strong ties between users and protection of privacy [61], this study responds to the calls from Varshney and Vishwakarma [38] to investigate online rumour-sharing behaviours on social media platforms other than Twitter. Moreover, analysing the rumour-sharing behaviours of Chinese social media users may contribute to understanding the mechanisms of rumormongering in the early stages of crises, given that the early propagation patterns in China are unclear [37]. This study enhances the understanding of online rumour-sharing behaviours by taking heed of the rumormongering process with respect to COVID-19 in the Chinese context.

5.3. Practical implications

This study has practical implications for individuals and governments. For individuals, a rational and accurate assessment of COVID-19 is beneficial. Individuals should search for relevant information from multiple sources using critical thinking. Our results indicate a positive relationship between social influence and rumour sharing. Therefore, information obtained from social networks should be treated cautiously, and individuals experiencing social pressure should take care not to believe rumours without fact-checking them. In addition, our empirical results indicate that fear as a moderating mechanism leads to increased rumour-sharing behaviours. Therefore, individuals should mitigate their fear of COVID-19 by enhancing their psychological resilience, which helps to moderate losses and increase adaptability to stressful or traumatic events [95]. Psychological education programmes are also recommended when experiencing psychological issues during a pandemic. Another effective coping mechanism is to learn more about COVID-19, such as how the virus is transmitted and how to eliminate the infection.

For governments, the first practical implication is the benefit of implementing multiple control measures (e.g. quarantining, social distancing and isolating infected people) because these measures are more effective than expected. These prevention and control measures not only inhibit the spread of the virus but may also increase the public's perception of a safe community environment, thus reducing the spread of rumours that may be detrimental in the fight against COVID-19. As social influence concerning COVID-19 continues to expand, the second implication for governments concerns public information and education on core issues related to the pandemic [96]. For example, authorities should publicise relevant information such as the number of infected people per region and available medical services. This information will mitigate the development of rumours. The government should also share knowledge about COVID-19 to enhance the public's understanding about infection risk and effective countermeasures. Moreover, positive measures should be taken to alleviate public fear. Specifically, publicity about recovered cases and good news about pandemic control may improve individuals' confidence. It is also beneficial to promote mental health education programmes to mitigate fear and other psychological issues among the public.

5.4. Limitations and future research

Although it has elicited several promising findings regarding rumour-sharing behaviours during the COVID-19 pandemic, this study has some limitations that may be addressed by future research. First, despite the timely collection of data in February 2020, when the COVID-19 outbreak in China was serious, the use of single-source, cross-sectional data did not permit an investigation of individual responses through different stages of the pandemic. Therefore, future researchers could use longitudinal and multisource data to reveal the relationships between environmental cues and rumormongering. Second, the generalisation of our results is constrained because we collected data in China and focused on the COVID-19 context. Future studies conducted in other countries and contexts could examine the generalisation of our results. Furthermore, a large proportion of our sample was young people, which also limits the generalisation of this study. Future studies may use a more age-diverse sample. Third, we analysed community safety, social influence and infection risk as environmental factors. However, there may be other environmental factors, such as perceived information overload [13], that trigger individual rumour-sharing behaviours. Fourth, we only identified fear as a moderating mechanism. However, the public has endured various negative psychological states during the COVID-19 pandemic (e.g. isolation, depression and anxiety) that may have influenced rumormongering [35]. Analysing the effects of these emotions is also an avenue for future studies.

6. Conclusion

Based on the stimulus–response framework, this study explores the underlying drivers of online rumour sharing about COVID-19 and the moderating effects of fear. The results indicate that perceptions of community safety and infection risk negatively affect online rumour sharing, while social influence positively affects online rumour sharing. Fear plays a significant contingent role on the effects of external stimuli on online rumour sharing, fuelling the spread of rumours with regard to COVID-19. Therefore, individuals are encouraged both to learn more related knowledge and to take psychological education programmes when experiencing psychological issues during a pandemic. Moreover, governments should take the responsibility to implement multiple control measures, publicise relevant information and promote mental health education programmes.

Declaration of conflicting interests

The author(s) declared no potential conflicts of interest with respect to the research, authorship and/or publication of this article.

Funding

The author(s) disclosed receipt of the following financial support for the research, authorship and/or publication of this article: This work was supported by the National Natural Science Foundation of China (72101169 and 71902135), the Ministry of Education in China Project of Humanities and Social Sciences (20XJC630003), the Peiyang Scholar Foundation (2020XRG-0074) and Shandong Industrial Internet Innovation and Entrepreneurship Community.

ORCID iD

Peng Luo  <https://orcid.org/0000-0003-1126-0329>

References

- [1] Lin TC, Huang SL and Liao WX. Examining the antecedents of everyday rumor retransmission. *Technol People* 2022; 35: 1326–1345.
- [2] Pan SL and Zhang S. From fighting COVID-19 pandemic to tackling sustainable development goals: an opportunity for responsible information systems research. *Int J Inf Manag* 2020; 55: 102196.
- [3] Leong CML, Pan SL, Ractham P et al. ICT-enabled community empowerment in crisis response: social media in Thailand flooding 2011. *J Assoc Inf Syst* 2015; 16: 174–212.
- [4] Mirbabaie M, Stieglitz S and Brünker F. Dynamics of convergence behaviour in social media crisis communication – a complexity perspective. *Inf Technol People* 2022; 35: 232–258.
- [5] Islam AN, Laato S, Talukder S et al. Misinformation sharing and social media fatigue during COVID-19: an affordance and cognitive load perspective. *Technol Forecast Soc Change* 2020; 159: 120201.
- [6] Naeem M and Ozuem W. Understanding misinformation and rumors that generated panic buying as a social practice during COVID-19 pandemic: evidence from Twitter, YouTube and focus group interviews. *Inf Technol People*. Epub ahead of print 27 October 2021. DOI: 10.1108/ITP-1101-2021-0061.
- [7] Wang X, Li Y, Li J et al. A rumor reversal model of online health information during the Covid-19 epidemic. *Inf Process Manag* 2021; 58: 102731.
- [8] Luo Y, Ma J and Yeo CK. Identification of rumour stances by considering network topology and social media comments. *J Inf Sci* 2020; 48: 118–130.
- [9] Ma J and Luo Y. The classification of rumour standpoints in online social network based on combinatorial classifiers. *J Inf Sci* 2019; 46: 191–204.
- [10] Zhu H. Rumour detection based on deep hybrid structural and sequential representation networks. *J Inf Sci*. Epub ahead of print 13 December 2021. DOI: 10.1177/016555152111056579.
- [11] Anderson RM, Heesterbeek H, Klinkenberg D et al. How will country-based mitigation measures influence the course of the COVID-19 epidemic? *Lancet* 2020; 395: 931–934.
- [12] Superio DL, Anderson KL, Oducado RMF et al. The information-seeking behavior and levels of knowledge, precaution, and fear of college students in Iloilo, Philippines amidst the COVID-19 pandemic. *Int J Disast Risk Reduct* 2021; 62: 102414.
- [13] Li X, Zhou Y, Wong YD et al. What influences panic buying behaviour? A model based on dual-system theory and stimulus-organism-response framework. *Int J Disast Risk Reduct* 2021; 64: 102484.
- [14] Chiang YC, Chu M, Lin S et al. Capturing the trajectory of psychological status and analyzing online public reactions during the coronavirus disease 2019 pandemic through Weibo posts in China. *Front Psychol* 2021; 12: 744691.
- [15] Pal A, Chua AY and Goh DH-L. How do users respond to online rumor rebuttals? *Comput Human Behav* 2020; 106: 106243.
- [16] Xu F, Luo X and Hsu C. Anger or fear? Effects of discrete emotions on employee's computer-related deviant behavior. *Inf Manag* 2020; 57: 103180.
- [17] Hassan SB and Soliman M. COVID-19 and repeat visitation: assessing the role of destination social responsibility, destination reputation, holidaymakers' trust and fear arousal. *J Destin Market Manag* 2021; 19: 100495.
- [18] Zheng D, Luo Q and Ritchie BW. Afraid to travel after COVID-19? Self-protection, coping and resilience against pandemic 'travel fear'. *Tour Manag* 2021; 83: 104261.
- [19] Bordia P and Difonzo N. Problem solving in social interactions on the Internet: rumor as social cognition. *Soc Psychol Quart* 2016; 67: 33–49.
- [20] Chua AYL and Banerjee S. Intentions to trust and share online health rumors: an experiment with medical professionals. *Comput Human Behav* 2018; 87: 1–9.
- [21] Eroglu SA, Machleit KA and Davis LM. Empirical testing of a model of online store atmospherics and shopper responses. *Psychol Market* 2003; 20: 139–150.
- [22] Tseng SY and Wang CN. Perceived risk influence on dual-route information adoption processes on travel websites. *J Bus Res* 2016; 69: 2289–2296.
- [23] DiFonzo N and Bordia P. Corporate rumor activity, belief and accuracy. *Publ Relat Rev* 2002; 28: 1–19.
- [24] Suki NM and Suki NM. Examination of peer influence as a moderator and predictor in explaining green purchase behaviour in a developing country. *J Clean Product* 2019; 228: 833–844.
- [25] Bristol T and Mangleburg TF. Not telling the whole story: teen deception in purchasing. *J Acad Market Sci* 2005; 33: 79–95.
- [26] Quintal VA, Lee JA and Soutar GN. Tourists' information search: the differential impact of risk and uncertainty avoidance. *Int J Tour Res* 2010; 12: 321–333.
- [27] Reisinger Y and Mavondo F. Travel anxiety and intentions to travel internationally: implications of travel risk perception. *J Travel Res* 2016; 43: 212–225.
- [28] DiFonzo N and Bordia P. Rumor, gossip and urban legends. *Diogenes* 2007; 54: 19–35.
- [29] Cenat JM, Blais-Rochette C, Kokou-Kpolou CK et al. Prevalence of symptoms of depression, anxiety, insomnia, posttraumatic stress disorder, and psychological distress among populations affected by the COVID-19 pandemic: a systematic review and meta-analysis. *Psychiatr Res* 2021; 295: 113599.
- [30] Cisler JM, Olatunji BO and Lohr JM. Disgust, fear, and the anxiety disorders: a critical review. *Clin Psychol Rev* 2009; 29: 34–46.

- [31] Vrhovc S and Mihelič A. Redefining threat appraisals of organizational insiders and exploring the moderating role of fear in cyberattack protection motivation. *Comput Secur* 2021; 106: 102309.
- [32] Rather RA. Demystifying the effects of perceived risk and fear on customer engagement, co-creation and revisit intention during COVID-19: a protection motivation theory approach. *J Destin Market Manag* 2021; 20: 100564.
- [33] Barua Z, Barua S, Aktar S et al. Effects of misinformation on COVID-19 individual responses and recommendations for resilience of disastrous consequences of misinformation. *Progr Disast Sci* 2020; 8: 100119.
- [34] Ali S, Khalid A and Zahid E. Is COVID-19 immune to misinformation? A brief overview. *Asian Bioethics Rev* 2021; 13: 255–277.
- [35] Song S, Yao X and Wen N. What motivates Chinese consumers to avoid information about the COVID-19 pandemic? The perspective of the stimulus-organism-response model. *Inf Process Manag* 2021; 58: 102407.
- [36] Pian W, Chi J and Ma F. The causes, impacts and countermeasures of COVID-19 ‘infodemic’: a systematic review using narrative synthesis. *Inf Process Manag* 2021; 58: 102713.
- [37] Nguyen TN, Li C and Niederee C. On early-stage debunking rumors on Twitter: leveraging the wisdom of weak learners. In: Ciampaglia G, Mashhadi A and Yasseri T (eds) *Social informatics – lecture notes in computer science*. Cham: Springer, 2017, pp. 141–158.
- [38] Varshney D and Vishwakarma DK. A review on rumour prediction and veracity assessment in online social network. *Expert Syst Appl* 2021; 168: 114208.
- [39] Zhang X, Dong X, Xu X et al. What influences physicians’ online knowledge sharing? A stimulus–response perspective. *Front Psychol* 2022; 12: 808432.
- [40] Jacoby J. Stimulus-organism-response reconsidered: an evolutionary step in modeling (consumer) behavior. *J Consum Psychol* 2002; 12: 51–57.
- [41] Peng C and Kim YG. Application of the stimuli-organism-response (S-O-R) framework to online shopping behavior. *J Internet Commer* 2014; 13: 159–176.
- [42] Spence KW. Cognitive versus stimulus-response theories of learning. *Psychol Rev* 1950; 57: 159–172.
- [43] Du J, van Koningsbruggen GM and Kerkhof P. Spontaneous approach reactions toward social media cues. *Comput Human Behav* 2020; 103: 101–108.
- [44] Yildirim M and Guler A. Positivity explains how COVID-19 perceived risk increases death distress and reduces happiness. *Personal Indiv Differ* 2021; 168: 110347.
- [45] Oh O, Agrawal M and Rao HR. Community intelligence and social media services: a rumor theoretic analysis of tweets during social crises. *MIS Quart* 2013; 37: 407–426.
- [46] Kim SC and Hawkins KH. The psychology of social media communication in influencing prevention intentions during the 2019 U.S. measles outbreak. *Comput Human Behav* 2020; 111: 106428.
- [47] Yoo W, Choi DH and Park K. The effects of SNS communication: how expressing and receiving information predict MERS-preventive behavioral intentions in South Korea. *Comput Human Behav* 2016; 62: 34–43.
- [48] Yoon C and Kim H. Understanding computer security behavioral intention in the workplace. *Inf Technol People* 2013; 26: 401–419.
- [49] Goyal A and Verma P. Do it yourself effect on restaurants – the pandemic effect: driven by the fear appeal theory. *J Hosp Tour Manag* 2021; 48: 76–87.
- [50] Kim J, Bae J and Hastak M. Emergency information diffusion on online social media during storm Cindy in U.S. *Int J Inf Manag* 2018; 40: 153–165.
- [51] Giesen CG, Schmidt JR and Rothermund K. The law of recency: an episodic stimulus-response retrieval account of habit acquisition. *Front Psychol* 2020; 10: 2927.
- [52] Zhang XM, Zhou HE, Zhang WW et al. Assessment of coronavirus disease 2019 community containment strategies in Shenzhen, China. *JAMA Netw Open* 2020; 3: e2012934.
- [53] Bao Y, Sun Y, Meng S et al. 2019-nCoV epidemic: address mental health care to empower society. *Lancet* 2020; 395: e37–e38.
- [54] Wang C, Horby PW, Hayden FG et al. A novel coronavirus outbreak of global health concern. *Lancet* 2020; 395: 470–473.
- [55] Rosnow RL and Fine GA. *Rumor and gossip: the social psychology of hearsay*. New York: Elsevier, 1976.
- [56] Wang Q, Yang X and Xi W. Effects of group arguments on rumor belief and transmission in online communities: an information cascade and group polarization perspective. *Inf Manag* 2018; 55: 441–449.
- [57] Tsarenko Y, Ferraro C, Sands S et al. Environmentally conscious consumption: the role of retailers and peers as external influences. *J Retail Cons Serv* 2013; 20: 302–310.
- [58] Moser AK. Thinking green, buying green? Drivers of pro-environmental purchasing behavior. *J Cons Market* 2015; 32: 167–175.
- [59] Katz E and Shibutani T. Improvised news: a sociological study of rumor. *Am Sociol Rev* 1969; 34: 781–782.
- [60] Wen HX, Wang C and Nie PY. Acceleration of rural households’ conversion to cleaner cooking fuels: the importance and mechanisms of peer effects. *Energ Policy* 2021; 154: 112301.
- [61] Jin XL, Zhou Z and Yu X. Predicting users’ willingness to diffuse healthcare knowledge in social media. *Inf Technol People* 2019; 32: 1044–1064.

- [62] Oh O, Gupta P, Agrawal M et al. ICT mediated rumor beliefs and resulting user actions during a community crisis. *Gov Inf Quart* 2018; 35: 243–258.
- [63] Hazel Kwon K and Raghav Rao H. Cyber-rumor sharing under a homeland security threat in the context of government Internet surveillance: the case of South-North Korea conflict. *Gov Inf Quart* 2017; 34: 307–316.
- [64] Garrett RK. Troubling consequences of online political rumoring. *Human Commun Res* 2011; 37: 255–274.
- [65] Joo D, Xu W, Lee J et al. Residents' perceived risk, emotional solidarity, and support for tourism amidst the COVID-19 pandemic. *J Destin Market Manag* 2021; 19: 100553.
- [66] Maser B and Weiermair K. Travel decision-making: from the vantage point of perceived risk and information preferences. *J Travel Tour Market* 1998; 7: 107–121.
- [67] Williams AM and Baláz V. Tourism, risk tolerance and competences: travel organization and tourism hazards. *Tour Manag* 2013; 35: 209–221.
- [68] Wen H and Lee YM. Effects of message framing on food allergy communication: a cross-sectional study of restaurant customers with food allergies. *Int J Hosp Manag* 2020; 89: 102401.
- [69] Boss S, Galletta D, Lowry PB et al. What do systems users have to fear? Using fear appeals to engender threats and fear that motivate protective security behaviors. *MIS Quart* 2015; 39: 837–864.
- [70] Lerner JS and Keltner D. Fear, anger, and risk. *J Pers Soc Psychol* 2001; 81: 146–159.
- [71] Rydell RJ, Mackie DM, Maitner AT et al. Arousal, processing, and risk taking: consequences of intergroup anger. *Pers Soc Psychol Bull* 2008; 34: 1141–1152.
- [72] Chen L and Yang X. Using EPPM to evaluate the effectiveness of fear appeal messages across different media outlets to increase the intention of breast self-examination among Chinese women. *Health Commun* 2019; 34: 1369–1376.
- [73] Witte K, Berkowitz JM, Cameron KA et al. Preventing the spread of genital warts: using fear appeals to promote self-protective behaviors. *Health Educ Behav* 1998; 25: 571–585.
- [74] Li A, Sun Y, Guo X et al. Understanding how and when user inertia matters in fitness app exploration: a moderated mediation model. *Inf Process Manag* 2021; 58: 102458.
- [75] Sun Y, Liu D, Chen S et al. Understanding users' switching behavior of mobile instant messaging applications: an empirical study from the perspective of push-pull-mooring framework. *Comput Human Behav* 2017; 75: 727–738.
- [76] Cooper B, Eva N, Fazlelahi FZ et al. Addressing common method variance and endogeneity in vocational behavior research: a review of the literature and suggestions for future research. *J Vocat Behav* 2020; 121: 103472.
- [77] Mullins R and Agnihotri R. Digital selling: organizational and managerial influences for frontline readiness and effectiveness. *J Acad Market Sci* 2022; 50: 800–821.
- [78] Venkatesh V, Morris MG, Davis GB et al. User acceptance of information technology: toward a unified view. *MIS Quart* 2003; 27: 425–478.
- [79] Colindres C, Bryce E, Coral-Rosero P et al. Effect of effort-reward imbalance and burnout on infection control among Ecuadorian nurses. *Int Nurs Rev* 2018; 65: 190–199.
- [80] Emerson E, Krnjacki L, Llewellyn G et al. Perceptions of safety and exposure to violence in public places among working age adults with disabilities or long-term health conditions in the UK: cross sectional study. *Publ Health* 2016; 135: 91–96.
- [81] Fornell C and Larcker DF. Evaluating structural equation models with unobservable variables and measurement error. *J Market Res* 1981; 18: 39–50.
- [82] Guo F, Restubog SLD, Cui L et al. What determines the entrepreneurial success of academics? Navigating multiple social identities in the hybrid career of academic entrepreneurs. *J Vocat Behav* 2019; 112: 241–254.
- [83] Yang Y, Zhu X, Song R et al. Not just for the money? An examination of the motives behind physicians' sharing of paid health information. *J Inf Sci*. Epub ahead of print 14 February 2021. DOI: 10.1177/0165551521991029.
- [84] Cohen J, Cohen P, West SG et al. *Applied multiple regression/correlation analysis for the behavioral sciences*. Mahwah, NJ: Lawrence Erlbaum, 2013.
- [85] Podsakoff PM and Organ DW. Self-reports in organizational research: problems and prospects. *J Manag* 1986; 12: 531–544.
- [86] Podsakoff PM, MacKenzie SB, Lee J-Y et al. Common method biases in behavioral research: a critical review of the literature and recommended remedies. *J Appl Psychol* 2003; 88: 879–903.
- [87] Liang H, Saraf N, Hu Q et al. Assimilation of enterprise systems: the effect of institutional pressures and the mediating role of top management. *MIS Quart* 2007; 31: 59–87.
- [88] Ahorsu DK, Lin CY, Imani V et al. The fear of COVID-19 Scale: development and initial validation. *Int J Ment Health Addict* 2020; 20: 1537–1545.
- [89] Xiao C. A novel approach of consultation on 2019 novel coronavirus (COVID-19)-related psychological and mental problems: structured letter therapy. *Psychiatr Invest* 2020; 17: 175–176.
- [90] Garg RK. Structural equation modeling of E-supplier selection criteria in mechanical manufacturing industries. *J Clean Product* 2021; 311: 127597.
- [91] Özgür H. Relationships between teachers' technostress, technological pedagogical content knowledge (TPACK), school support and demographic variables: a structural equation modeling. *Comput Human Behav* 2020; 112: 106468.
- [92] DiFonzo N, Suls J, Beckstead JW et al. Network structure moderates intergroup differentiation of stereotyped rumors. *Soc Cognit* 2014; 32: 409–448.

- [93] Ahmad M, Iram K and Jabeen G. Perception-based influence factors of intention to adopt COVID-19 epidemic prevention in China. *Environ Res* 2020; 190: 109995.
- [94] Yildirim M, Gecer E and Akgul O. The impacts of vulnerability, perceived risk, and fear on preventive behaviours against COVID-19. *Psychol Health Med* 2021; 26: 35–43.
- [95] Rodriguez-Llanes JM, Vos F and Guha-Sapir D. Measuring psychological resilience to disasters: are evidence-based indicators an achievable goal? *Environ Health* 2013; 12: 1–10.
- [96] Luu TP and Follmann R. The relationship between sentiment score and COVID-19 cases in the United States. *J Inf Sci*. Epub ahead of print 8 January 2022. DOI: 10.1177/01655515211068167.

Appendix I

Measures

Online rumour sharing [78]

I have shared some virus-related rumours on my Weibo or WeChat when I did not know they were rumours.

I have shared some virus-related rumours to my family and friends on my Weibo or WeChat when I did not know they were rumours.

I have shared some virus-related rumours unconsciously on my Weibo or WeChat when I did not know they were rumours.

Community safety [80]

During COVID-19, I felt safe in the community of home and workplace.

During COVID-19, I will not be infected in the community of home and workplace due to the efficient controls.

Social influence [24]

I often discuss the virus with my friends/relatives.

I often learn about the virus information from my friends/relatives.

I often share with my friends/relatives about virus information.

Infection risk [79]

Risk of contracting infectious disease is existed by contacting patients with infectious diseases.

Risk of transmitting infectious diseases to others (e.g. family and friends) is existed by caring for patients with infectious diseases.

Fear [69]

I was worried about the prospect of virus infection from others.

I was frightened about the prospect of virus infection from others.

I was anxious about the prospect of virus infection from others.